

#S7/97

PRICE \$5.95

**QUALITY** **FAST DELIVERY** **ECONOMY**



**WHITE** ...*performance beyond the ordinary*  
**DIAMOND**

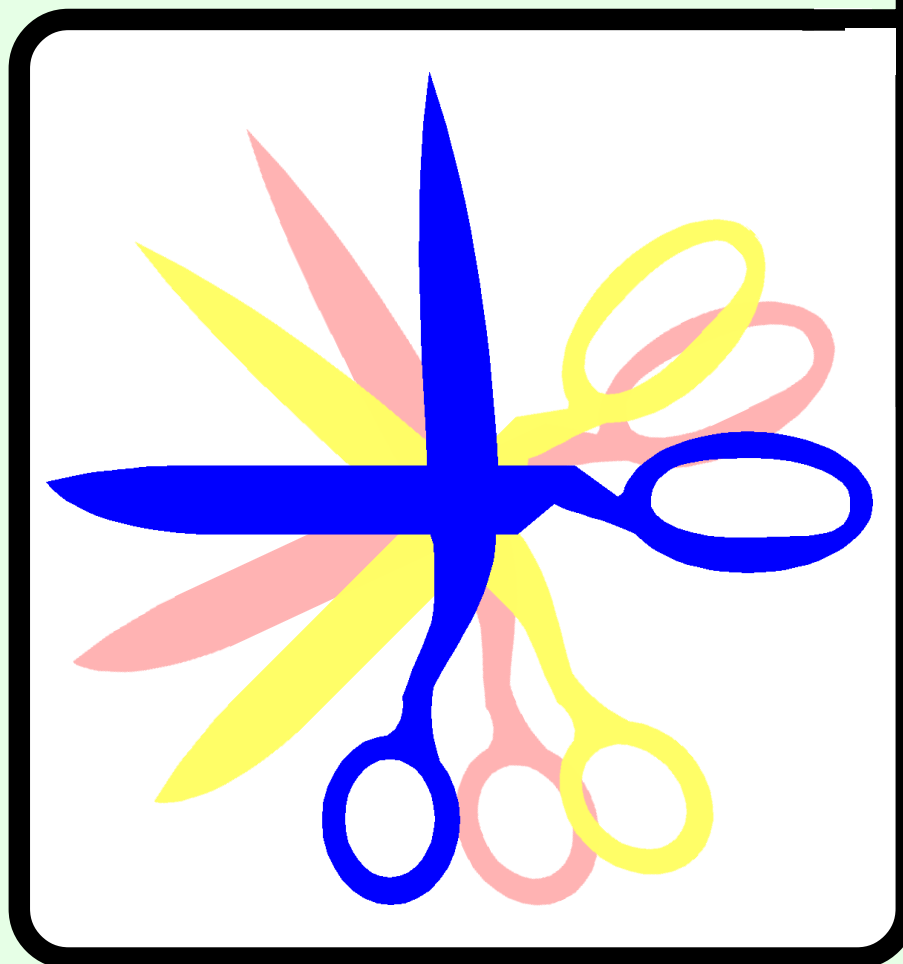

- **WISS**
- **MUNDIAL**
- **GOLD SEAL**
- **BELMONT**
- **FISKARS**
- **ACCESSORIES**

***Your Cutting Supply Resource***

**Diamond  
Needle  
Corp.**



**WHITE  
DIAMOND**

G.P.O. 1355  
159-163 WEST 25<sup>TH</sup> STREET  
NEW YORK, NY 10001  
E-mail: [Diamond-Needle@worldnet.att.net](mailto:Diamond-Needle@worldnet.att.net)



**212-929-2277**  
**CALL TOLL-FREE**  
**1-800-221-5818**



**1-800-833-3363**  
(DOMESTIC)  
**212-242-8882**  
(INTERNATIONAL)

### *Special* 8" Kevlar Scissor

Specially designed for cutting Kevlar materials. Excellent for cutting Plastic, Canvas, Upholstery, Quilting and many other materials.

**Micro-serrated** blades made of high carbon alloy steel with molybdenum and vanadium blades.

**C18425**



### **EW Heavy Duty Leather Holster**

Made of thick, high grade leather, stitched and riveted for extra strength with a built in belt slot. Will accommodate almost any scissor up to 12" in length. **Stop wasting time looking for your scissors!** Much safer than leaving them on a table, a machine or the floor.

**DN103**



1/02/10



**Diamond  
Needle  
Corp.**



60 Commerce Rd. – Carlstadt, NJ 07072

phone: 201-507-1771 toll free: 800-221-5818

fax: 201-507-1715 toll free: 800-833-3363

e-mail: [info@diamondneedle.com](mailto:info@diamondneedle.com)

**EW**  
**WHITE  
DIAMOND**



**Quality-Made** Scissors & Shears  
*Reasonable Prices that make sense !*

**THREAD NIPPER**

Made in Italy

Hot Drop Forged Steel  
*Quality Made*

*Nipper comfortably fits hand leaving fingers free to handle materia l*  
*Balanced long life springs for effortless performance*



**#504N** 4-1/2" Length (1-1/4" cut)

*Ball Bearing Washer*  
**for smooth movement**

**HEAVY DUTY**

**10" & 12"**

**Tailor Shears**

Hot Drop Forged Steel  
*Quality Made*

- Hardened, Resharpenable Blades Hold Edges Sharp
- BRASS COMFORT HANDLES FOR SURE GRIP !



**#571/10** 10" (250mm) Overall Length / 4-7/8" (124mm) Cut  
**#571/12** 12" (305mm) Overall Length / 6-1/8"- (155mm) Cut

**UPHOLSTERY SCISSOR**

*Best Quality*

- Durable Stainless Steel Blades
- Ambidextrous,
- Rounded Safety Points
- Comfort Handles
- Serrations near pivot grip fabric to prevent slippage while cutting



**#USS/160** 6" Scissors with teeth (1-1/4" cut)  
**#USS/175** 7" Scissors with teeth (2" cut)

**UPHOLSTERY SCISSOR**

*Economy Version*

- Stainless Steel Blades
- Ambidextrous Handles
- Rounded Safety Points
- Adjustable Pivot Screw



**#CSS/175B** 7" Length (2" cut)

**EMBROIDERY SCISSORS**

Hot Drop Forged Steel  
*Quality Made*

- Double sharp point
- Finely tapered blades

**#735/3-1/2** 3-1/2" Length (1-1/4" cut)  
**#735/5** 5" Length (2" cut)  
**#735/6** 6" Length (2-5/8" cut)



Made in Italy

**UTILITY SCISSOR**

Hot Drop Forged Steel  
*Quality Made*

- Nickel plated blades
- Black handles
- High leverage



Elongated Shank / Regular Handles

**#576/8** 8" Length (3" Cut)

Made in Italy

**STRAIGHT TRIMMERS**

Hot Drop Forged Steel  
*Quality Made*

**#355-6B** 6" Length (2-5/8" cut)  
**#355-7B** 7" Length (3-1/8" cut)  
**#355-8B** 8" Length (3-3/4" cut)  
**#355-9KE** 9" Length (4-3/8" cut)



Made in Italy  
 Made in USA

**BENT TRIMMERS**

Hot Drop Forged Steel  
*Quality Made*

**#571/6i** 6" Length (2-5/8" cut)  
**#571/7i** 7" Length (3-1/8" cut)  
**#571/8i** 8" Length (3-3/4" cut)  
**#571/9i** 9" Length (4-5/8" cut)



Made in Italy

**Diamond Needle Corp**

60 Commerce Rd, Carlstadt, NJ 07072  
 Phone: (201)507-1771 (800)221-5818  
 Fax: (201)507-1715 (800)833-3363 E-mail: info@diamondneedle.com





**Quality-Made** Scissors & Shears  
*Reasonable Prices that make sense !*

**THREAD NIPPER**

Made in USA

Hot Drop Forged Steel

*Quality Made*

*Nipper comfortably fits hand leaving fingers free to handle material /  
 Balanced long life springs for effortless performance*



#504N 4-1/2" Length (1-1/4" cut)

**HEAVY DUTY**

**10" SHEAR**

Hot Drop Forged Steel

*Quality Made*

- Hardened, Resharpenable Blades Hold Edges Sharp
- BRASS COMFORT HANDLES FOR SURE GRIP !



#571/10 10" (250mm) Overall Length / 4-7/8" (124mm) Cut

**UPHOLSTERY SCISSOR**

*Best Quality*

- Durable Stainless Steel Blades
- Ambidextrous,
- Rounded Safety Points
- Comfort Handles
- Serrations near pivot grip fabric to prevent slippage while cutting



#USS/160 6" Scissors with teeth (1-1/4" cut)

#USS/175 7" Scissors with teeth (2" cut)

**UPHOLSTERY SCISSOR**

*Economy Version*

- Stainless Steel Blades
- Ambidextrous Handles
- Rounded Safety Points
- Adjustable Pivot Screw



#CSS/175B 7" Length (2" cut)

**EMBROIDERY SCISSORS**

Hot Drop Forged Steel

*Quality Made*

- Double sharp point
- Finely tapered blades

#735/3-1/2 3-1/2" Length (1-1/4" cut)

#735/5 5" Length (2" cut)

#735/6 6" Length (2-5/8" cut)



Made in Italy

**UTILITY SCISSOR**

Hot Drop Forged Steel

*Quality Made*

- Nickel plated blades
- Black handles
- High leverage



Elongated Shank / Regular Handles

#576/8 8" Length (3" Cut)

Made in Italy

**STRAIGHT TRIMMERS**

Hot Drop Forged Steel

*Quality Made*

#355-6B 6" Length (2-5/8" cut)

#355-7B 7" Length (3-1/8" cut)

#355-8B 8" Length (3-3/4" cut)

#355-9KE 9" Length (4-3/8" cut)



Made in Italy

Made in USA

**BENT TRIMMERS**

Hot Drop Forged Steel

*Quality Made*

#571/6i 6" Length (2-5/8" cut)

#571/7i 7" Length (3-1/8" cut)

#571/8i 8" Length (3-3/4" cut)

#571/9i 9" Length (4-5/8" cut)



Made in Italy

**Diamond Needle Corp**

60 Commerce Rd, Carlstadt, NJ 07072

Phone: (201)507-1771 (800)221-5818

Fax: (201)507-1715 (800)833-3363 E-mail: info@diamondneedle.com



# KRETZER SCISSORS

## ARAMIDSCHERE

Leichte Zuschneideschere mit mikroverzahnter Schneide speziell für Glasfasern und Aramid.

## ARAMID SCISSORS

Light tailor's shears with micro-serrated blades, especially for glass fibres and aramids.

## TIJERAS DE ARAMIDA

Tijeras de sastrerías ligeras con hojas micro-dentadas, especiales para fibras de vidrio y aramidas.

## CISEAUX POUR ARAMIDE

Ciseaux de coupe légers, à lames microdentées avec une pointe très fine spécialement pour les fils glacés et aramide.

### TEC X

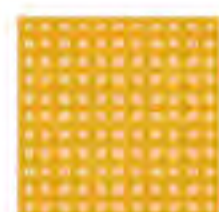

Aramid Composites

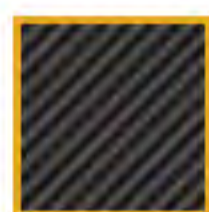

Carbon Carbon



Glasfaser Fibre-glass



Art-Nr. Item-No.	Zoll Inch	cm cm	Zoll Inch	cm cm	Dura-Steel	Botec-Cut	Perfect-Grip	Ergo-Grip	Aramid	Glas	Carbon
732020	8,0"	20,0	3,4"	8,5	✓	✓	✓	-	-	✓	✓

## ARAMIDSCHERE

Universelle Zuschneideschere mit mikroverzahnter Schneide speziell für Glasfasern und Aramide.

## ARAMID SCISSORS

Sturdy universal tailor's shears with micro-serrated blades, especially for glass fibres and aramids.

## TIJERAS DE ARAMIDA

Tijeras de sastrerías resistentes y universales con micro-hojas dentadas, especiales para las fibras de vidrio y aramidas.

## TIJERAS DE ARAMIDA

Ciseaux de coupe universels, à lames microdentées avec une pointe très fine spécialement pour les fils glacés et aramide.



### TEC X

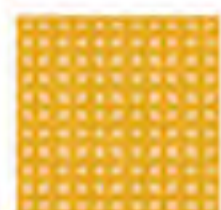

Aramid Composites

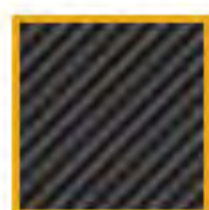

Carbon Carbon



Glasfaser Fibre-glass



Art-Nr. Item-No.	Zoll Inch	cm cm	Zoll Inch	cm cm	Dura-Steel	Botec-Cut	Perfect-Grip	Ergo-Grip	Aramid	Glas	Carbon
733225	10,0"	25,0	4,7"	12,0	✓	✓	✓	-	-	✓	✓

## NÄHSCHERE

Universelle Zuschneideschere für den exakten Schnitt aller herkömmlichen Materialien.

## SEWING SCISSORS

Universal scissors for precise cutting for all conventional materials.

## TIJERA DE COSTURA

Tijera de uso universal para un corte exacto de todo tipo de materiales convencionales.

## CISEAUX DE COUTURE

Ciseaux universels pour la coupe exacte de toutes les matières courantes.

### HOBBY



Art-Nr. Item-No.	Zoll Inch	cm cm	Zoll Inch	cm cm	Dura-Steel	Botec-Cut	Perfect-Grip	Ergo-Grip
782020	8,0"	20,0	3,4"	8,5	✓	✓	✓	-

## TEPPICHSCHERE

Stabile Schere für fast alle Bodenbeläge.

## CARPET SCISSORS

Sturdy scissors for almost any floor covering.

## TIJERA PARA ALFOMBRAS

Tijera sólida para casi todo tipo de superficies.

## CISEAUX À MOQUETTES

Ciseaux stables pour presque tous les revêtements de sols.

### PROFI



Art-Nr. Item-No.	Zoll Inch	cm cm	Zoll Inch	cm cm	Dura-Steel	Botec-Cut	Perfect-Grip	Ergo-Grip
773225	10,0"	25,0	4,9"	12,5	✓	✓	✓	-

# HAND MATES

## IMPROVE PRODUCTIVITY

# Hand~Mates™

SUPPORT GLOVES

**Hundreds of Uses Including...**  
Sewing & Quilting, Craft & Hobby Work, Computer Use, Assembly Work, Food Processing...and more!



**Hand~Mates™ Provide...**  
Massage / Heat/ Support  
Relief from Nagging Aches and Pain

**Should be used any time repetitive hand motion causes fatigue to hands or wrist.**

Start your day by putting on Hand~Mates™ and your hands will feel more comfortable and relaxed than ever before!

### Heat...

Naturally generated by the body, warmth is retained within the tightly knit fabric. This keeps muscles relaxed and stimulates circulation.

### Support...

Just like what support hose do for legs...Hand~Mates™ comfortably reinforce the palm and wrist – leaving your fingers free to handle your work.

### Massage...

The gentle “give and take” of the fabric keeps muscles free from fatigue and promotes better circulation...



Insert your ring and middle fingers together through the center hole.

Hand~Mates™ can be worn under protective or sport gloves.

**Washable**  
88% Nylon / 12% Spandex

# Hand~Mates



## Size Guide

X-Large

Large

Medium

Small

Place palm here and measure across knuckles.

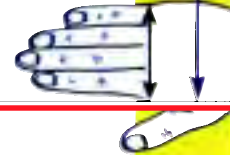

## ECONOMICALLY PRICED

#HM-501 SMALL #HM-502 MEDIUM #HM-503 LARGE #HM-504 EXTRA LARGE

# Diamond Needle Corp.

GPO BOX 1355 • 159 W 25 St. • New York, NY 10001  
Phone: (212) 929-2277 • (800) 221-5818  
FAX: (212) 242-8882 • (800) 833-3363



WHITE  
DIAMOND

NOT RESPONSIBLE FOR TYPOGRAPHICAL ERRORS.

Through the support of our valued customers worldwide, we are pleased to introduce our new **Scissors & Shears** and **Accessories** catalog.

This catalog is an in-depth listing and illustration of cutting tools available from leading manufacturers. Our extensive lines are economically priced to meet your specific requirements at multiple quantity levels. We maintain a vast inventory to assure prompt delivery at all times.

This catalog's illustrations and descriptions help you find the right tools, new ideas and answers for many cutting applications. Because decisions are made dependent on quality information, we have devoted considerable efforts to make this useful information easier to access. We recognize the importance of your support. Please feel free to contact us anytime with your orders, inquiries and recommendations as to how we can improve our products and services. We never forget that we've got to earn your business all of the time.

## GLOSSARY

<b>Knife-Edge</b>	The bottom blade is ground to a standard 20 degree bevel. The top blade bevel is increased from 30 degrees to 50 degrees. The easiest cut but sacrifices edge life.
<b>Hot Drop-Forged</b>	Construction process that provides sturdiness and lasting sharpness. Tempered and hardened scissors can be sharpened again and again.
<b>Inlaid (Wiss)</b>	Precision construction process that offers extraordinary edge properties for high performance and features the "Easy-set" pivot.
<b>Scissors</b>	The finger bows are identical.
<b>Shears</b>	The finger bows are <b>NOT</b> identical, or any scissor over 6" in length.
<b>Compound Action</b>	The insertion of gears or levers to mechanically multiply the cutting power of the shears.
<b>Ice Tempered</b>	A special hardening process to extend the life of the cutting edge.

## QUICK-INDEX

<b>PRODUCT/BRAND</b>	<b>PRODUCT</b>	<b>PAGE</b>
<b>HAND-MATES</b>	Support Gloves .....	2
<b>WISS</b>	Scissors & Shears .....	4-6
	Specialty Shears & Snips .....	7-10
	Thread Clips .....	10
<b>MUNDIAL</b>	Scissors & Shears .....	11-12
	Specialty Shears & Snips .....	13-14
	Lightweight Scissors & Shears ..	15-16
<b>WOLFF</b>	Scissors Sharpener .....	17
<b>GOLD SEAL</b>	Thread Nippers .....	18-19
	Hones .....	19
	Scissors & Shears .....	20-21
<b>BELMONT</b>	Scissors & Shears .....	22-24
	Specialty Scissors & Snips .....	25-27
	Thread Nippers .....	27
<b>FISKARS</b>	Scissors, Shears, Snips, Cutters	28-29
<b>CHAINEX</b>	Mesh Gloves, Aprons .....	30-31
<b>TOOLS</b>	Tweezers, Seam Rippers, etc. ....	32
<b>DIXON</b>	Marking Crayons and Pencils .....	33

## The WISS Quality Story

The name WISS has been synonymous with fine quality shears and scissors since 1848. This position of eminence is unparalleled in the industry and has been achieved by maintaining a standard of manufacturing excellence that has made WISS a household word in this country and throughout the world.

The manufacture of WISS shears and scissors begins with the finest quality cutlery steel and a knowledge of metallurgy achieved from years testing and analyzing these products at every stage of production.

The combination of this with the dedication and experience of skilled craftsmen, is responsible for the cutting edge superiority that has established WISS shears and scissors as the standard of excellence in the industry.

### HEAVY DUTY INDUSTRIAL SHEARS

#### INLAID

Professional, Industrial/Tailor. Ideal for heavy-duty extensive, multiple layer cutting.



- Hot drop-forged, polished blades with black handle.
- Patented set-easy pivot, easy hand adjustment.

ITEM NO.	FULL LENGTH	CUT LENGTH
W20	10" - 260mm	4 3/4" - 121mm
W20LH	10" - 260mm	4 3/4" - 121mm
W22	12" - 311mm	6 1/8" - 155mm

### HEAVY DUTY INDUSTRIAL SHEARS with CUSHION GRIP INLAID

Red **Cushion Grip** handle provides maximum comfort.

#### ERGONOMIC



- Hot drop-forged, polished blades.
- Patented set-easy pivot, easy hand adjustment.

ITEM NO.	FULL LENGTH	CUT LENGTH
W20P	10" - 260mm	4 3/4" - 121mm
W20LHP	10" - 260mm	4 3/4" - 121mm
W22P	12" - 311mm	6 1/8" - 155mm

### HEAVY DUTY INDUSTRIAL SHEARS

#### INLAID

The cutting blade is ground to knife-edge for faster, cleaner, easier cutting of today's synthetic fibers.

#### KNIFE-EDGE



- Ideal for heavy-duty cutting, upholstery, carpet and fabric.
- Hot drop-forged, polished blades with black handles.
- Patented set-easy pivot, easy hand adjustment.

ITEM NO.	FULL LENGTH	CUT LENGTH
W1225	10" - 260mm	4 3/4" - 121mm
W1226	12" - 311mm	6 1/8" - 155mm

### HEAVY DUTY HIGH LEVERAGE INDUSTRIAL SHEARS INLAID

The cutting blade is ground to knife-edge and the red **Cushion Grip Elongated** handle design allows extra leverage for cutting extra thick or tough upholstery, carpet and fabric.

#### KNIFE-EDGE

#### ERGONOMIC



- Hot drop-forged, polished blades.
- Patented set-easy pivot, easy hand adjustment.

ITEM NO.	FULL LENGTH	CUT LENGTH
W1225HLSP	10" - 260mm	4 3/4" - 121mm



**UPHOLSTERY, CARPET, DRAPERY  
& FABRIC SHEARS**

**INLAID**

Thicker, heavy duty blades cut through multiple layers and tough materials.



- Hot drop-forged, polished blades with black handle.
- Patented set-easy pivot, easy adjustment.

<u>ITEM NO.</u>	<u>FULL LENGTH</u>	<u>CUT LENGTH</u>
<b>W20W</b>	10" - 260mm	4 3/4" - 121mm
<b>W22W</b>	12" - 311mm	6 1/8" - 155mm

**BENT TRIMMERS**

**INLAID**

Professional pattern cutters. Specially designed with bent (off-set) handles. Ideal for cutting fabrics of all weights without lifting shears off of cutting board, or cutting into board or table.



- Hot drop-forged, nickel plated blades with black handle.
- Patented set-easy pivot, easy adjustment.

<u>ITEM NO.</u>	<u>FULL LENGTH</u>	<u>CUT LENGTH</u>
<b>W27</b>	7" - 182mm	3 1/8" - 79mm
<b>W28</b>	8" - 206mm	3 3/4" - 95mm
<b>W29</b>	9" - 100mm	4" - 100mm

**UPHOLSTERY, CARPET, DRAPERY  
& FABRIC SHEARS with CUSHION GRIP**

**INLAID**

Red **Cushion Grip** handle provides maximum comfort. Thicker, heavy duty blades cut through multiple layers and tough materials.

**ERGONOMIC**



- Hot drop-forged, polished blades.
- Patented set-easy pivot, easy hand adjustment.

<u>ITEM NO.</u>	<u>FULL LENGTH</u>	<u>CUT LENGTH</u>
<b>W20WP</b>	10" - 260mm	4 3/4" - 121mm
<b>W22WP</b>	12" - 311mm	6 1/8" - 155mm

**STRAIGHT TRIMMERS**

**INLAID**

Professional, for industrial, household, utility chores. Truly, general purpose.



- Hot drop-forged, nickel plated blades with black handle.
- Patented set-easy pivot, easy adjustment.

<u>ITEM NO.</u>	<u>FULL LENGTH</u>	<u>CUT LENGTH</u>
<b>W36</b>	6" - 158mm	2 5/8" - 66mm
<b>W37</b>	7" - 182mm	3 1/8" - 79mm
<b>W38</b>	8" - 206mm	3 3/4" - 95mm
<b>W39</b>	9" - 235mm	4 3/8" - 112mm
<b>W30</b>	10" - 260mm	4 7/8" - 124mm

## BENT TRIMMERS - SOLID STEEL

Professional **Dressmaker's**. These high carbon steel shears provide outstanding cutting ability and durability on fabric of all weights in the true Wiss tradition.



- Hot drop-forged, nickel plated, black handle.
- Easy pivot adjustment.

ITEM NO	FULL LENGTH.	CUT LENGTH
<b>W426</b>	6" - 160mm	2 5/8" - 68mm
<b>W427</b>	7" - 182mm	3 1/8" - 79mm
<b>W428</b>	8" - 206mm	3 3/4" - 95mm

## STRAIGHT TRIMMERS - SOLID STEEL

Professional, general purpose high carbon solid steel shears for cutting fabric, twine, paper, binding and almost any other miscellaneous household cutting task.



- Hot drop-forged, nickel plated with black handle.
- Easy pivot hand adjustment.

ITEM NO.	FULL LENGTH	CUT LENGTH
<b>W436</b>	6" - 160mm	2 5/8" - 66mm
<b>W437</b>	7" - 182mm	3 1/8" - 79mm
<b>W438</b>	8" - 206mm	3 3/4" - 95mm

## SEWING SCISSORS - SOLID STEEL

Excellent for trimming light materials, ripping seams and for general sewing or craft purposes.



- Hot drop-forged, fully nickel plated.
- One sharp and one blunt point with ring handle.

ITEM NO.	FULL LENGTH	CUT LENGTH
<b>W715</b>	5" - 134mm	2 1/4" - 57mm
<b>W716</b>	6" - 156mm	2 3/4" - 70mm

## PINKING SHEARS - SOLID STEEL

**Pinking shears** play a double role, used to create attractive outer edges as well as their established function of finishing inside seams with ravel resistant zig-zag edge.



- Hot drop-forged, fine cutlery steel, nickel plated blades and black handle.
- Bearing pivot reduces friction and finger fatigue.
- Extra large teeth provide decorative finish.

ITEM NO.	FULL LENGTH	CUT LENGTH
<b>WCB9</b>	9" - 228mm	3 1/4" - 83mm
<b>WAA</b>	10" - 270mm	3 7/8" - 97mm

## TAILOR'S POINT - SOLID STEEL

Professional model, extra sturdy, ideal for light tailoring task such as, material, darning, ripping, millinery.



- Hot drop-forged, nickel plated with black handle.
- Double sharp points with larger ring handle.

ITEM NO	FULL LENGTH	CUT LENGTH
<b>W75L</b>	5" - 130mm	2" - 51mm

## SEWING & EMBROIDERY SCISSORS - SOLID STEEL

Very fine sharp points. Useful for fine accurate cuts and trimming threads

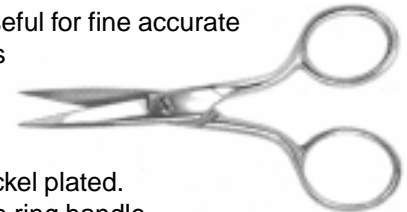

- Hot drop-forged, fully nickel plated.
- Double sharp points with ring handle.

ITEM NO.	FULL LENGTH	CUT LENGTH
<b>W763 1/2</b>	3 1/2" - 92mm	1 1/4" - 31mm
<b>W764</b>	4" - 105mm	1 3/8" - 35mm
<b>W765</b>	5" - 130mm	2" - 51mm
<b>W766</b>	6" - 156mm	2 1/2" - 64mm

**SPECIALTY SHEARS & SNIPS**

**BELT & LEATHER SHEARS**

**INLAID**

Specially designed, thick heavy-duty blades with one blade serrated and the other edged. Specifically constructed for leather and other tough and thick material cutting.



- Hot drop-forged, nickel plated with black handle.
- Patented set-easy pivot.

<u>ITEM NO.</u>	<u>FULL LENGTH</u>	<u>CUT LENGTH</u>
<b>W8BLT</b>	8" - 222mm	3" - 72mm

**RUG SHEARS for HOOK & CANDLEWICK RUGS - SOLID STEEL**

Specially designed with elongated shank and offset handle to get closer to level carpet surface.



- Hot drop-forged, nickel plated, black handle.
- Easy pivot adjustment.

<u>ITEM NO.</u>	<u>FULL LENGTH</u>	<u>CUT LENGTH</u>
<b>WRS1</b>	8" - 204mm	2 3/4" - 70mm

**INDUSTRIAL UTILITY SHEARS**

**INLAID**

Specially designed with elongated shank for maximum cutting leverage. Used extensively in poultry processing as well as in auto, marine, upholstery, florist, etc.



- Hot drop-forged, high carbon steel, nickel plated commercial finish.
- Patented set-easy pivot.

<u>ITEM NO.</u>	<u>FULL LENGTH</u>	<u>CUT LENGTH</u>
<b>W1DS</b>	8" - 216mm	3" - 76mm

**LARGE RING INDUSTRIAL SHEARS**

**INLAID**

Specially designed with elongated shank for maximum cutting leverage and **new enlarged lower ring handle** for added comfort. Also available with cushion grip and safety points.

**ERGONOMIC**



- Hot drop-forged, high carbon steel, commercial finish.
- Patented set-easy pivot.

<u>ITEM NO.</u>	<u>FULL LENGTH</u>	<u>CUT LENGTH</u>
<b>W1DSLRL</b>	9.25" - 235mm	3" - 76mm
<b>W1DSLRLP</b> (Plastisol Grips)		
<b>W1DSLRLSP</b> (Safety Points)		
<b>W1DSLRLSPP</b> (Plastisol Grips/Safety Points)		

**HIGH LEVERAGE SHEARS - SOLID STEEL**

Constructed with heavy-duty blades and elongated shank. Provides **maximum leverage** and ease of cutting. Extensively used for florist wire cutting as well as extra thick or tough materials.

**HIGH LEVERAGE**



- Nickel plated blades with black handle.
- Hot drop-forged, solid steel.
- Serrated blades for firm grip of material.

ITEM NO.	FULL LENGTH.	CUT LENGTH
W2DA	8" - 210mm	2 1/4" - 57mm

**ELECTRICIAN'S SCISSORS - SOLID STEEL**

Ideal for wire splicing, cutting insulation, stripping insulation and cutting harness ties. Perfect tool for any maintenance shop.



- Hot drop-forged, fully nickel plated.
- Scraper and file on back edge of blades.

ITEM NO.	FULL LENGTH	CUT LENGTH
W175E	5" - 133mm	1 7/8" - 48mm

**SNIPS FOR CUTTING KEVLAR**

Special heat treated high carbon solid steel. Deeper serration on one blade provides prolonged life when cutting Kevlar or other tough composite materials.

**HIGH LEVERAGE**



- Black oxide industrial finish.
- Hot drop-forged, high grade carbon steel.
- Will cut Kelvar and Spectra.

ITEM NO.	FULL LENGTH	CUT LENGTH
WKV2	8" - 210mm	2" - 51mm

**POCKET SCISSORS - SOLID STEEL**

Two blunt rounded ends prevent points from tearing or ripping. Heavy-duty flat pattern and ring handle makes them a convenient easy to use tool.



- Hot drop-forged, fully nickel plated.

ITEM NO.	FULL LENGTH	CUT LENGTH
W064	4" - 108mm	1 3/4" - 44mm
W065	5" - 133mm	2 1/4" - 58mm
W166	6" - 158mm	2 3/4" - 70mm
W166L (large ring handle)	6" - 165mm	2 3/4" - 70mm

**METAL-WIZZ, MULTI PURPOSE SNIPS**

Cuts curves, straight or any combination. Designed for craftsmen. Ideal for cutting lighter gauge metal, screening, shingles, carpet, etc.

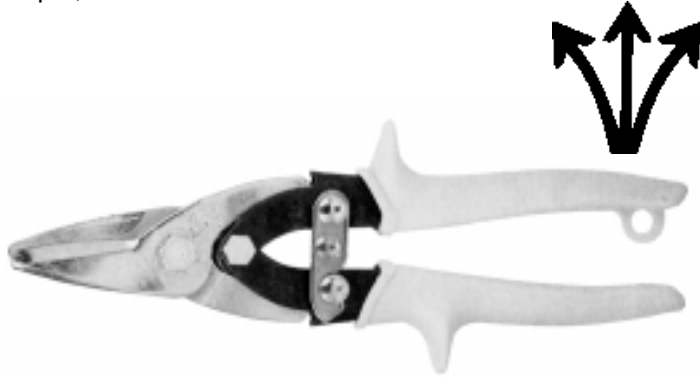

- Compound spring action for effortless cutting.
- Serrated jaw, non-slip cushion grips.

ITEM NO.	FULL LENGTH	CUT LENGTH
<b>WMPC3</b>	9" - 229mm	1 3/8" - 35mm

**METALMASTER COMPOUND ACTION SNIPS**

The jaws are made of extra tough, wear resistant molybdenum steel. Advanced technological cutting tool, ideal for industrial workers, maintenance specialists and professional metal workers. A versatile tool that will cut with half the effort required of conventional snips and will handle even the most difficult jobs.



- Non-slip serrated jaw allows for compound lever action.
- Compound spring-action for fast, effortless cutting.
- Handle of high tensile strength alloy.
- Handy hang-up hole
- Non-slip, textured grips and safety latch.

ITEM NO	FULL LENGTH.	CUT LENGTH
<b>WM1R</b> (LEFT CUT)	9 3/4" - 248mm	1 3/8" - 35mm
<b>WM2R</b> (RIGHT CUT)	9 3/4" - 248mm	1 3/8" - 35mm
<b>WM3R</b> (STRAIGHT CUT)	9 3/4" - 248mm	1 3/8" - 35mm

**STRAIGHT PATTERN, SOLID STEEL TINNER'S SNIPS**

Traditional tools of sheet metal trades, and craftsmen. Ideal for straight cutting and/or wide curves. Handyman's tool.



- Cushion handle for comfort and grip.

ITEM NO.	FULL LENGTH	CUT LENGTH
<b>WA13</b>	7" - 178mm	1 3/4" - 44mm
<b>WA12</b>	8" - 209mm	2" - 51mm
<b>WA11</b>	9" - 248mm	2 1/4" - 57mm
<b>WA10</b>	11" - 279mm	2 1/2" - 63mm
<b>WA9</b>	12" - 317mm	3" - 76mm

**MULTIMASTER/MULTIPURPOSE SNIP**

Anything that goes into the powerful jaws of this multimaster, isn't coming out in one piece. Great for making long, fast cuts in several types of material, including: paper, plastic, sheet metal, aluminum, vinyl siding, screening and many more.

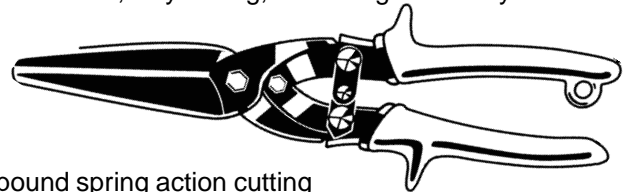

- Compound spring action cutting
- Non-slip serrated jaws, non-slip textured grips
- Cuts up to 20 gauge steel

ITEM NO.	FULL LENGTH	CUT LENGTH
<b>WM300</b>	13 1/2" - 343mm	3" - 76mm

**INDUSTRIAL TRIMMING, GRAPE THINNING & ORCHID SNIPS/SOLID STEEL**

Extensively used as industrial trimmers. They are ideal for pattern cutting. The short blades and coil spring handle provide control in close accurate cutting or trimming.



- Hot drop-forged, solid steel.
- Heavy pattern with adjustable nut.

ITEM NO.	FULL LENGTH	CUT LENGTH
<b>WC4AS</b>	8" - 204mm	2 1/4" - 57mm

(straight blades)

**KITCHEN SHEARS - STAINLESS STEEL**

Serves many purposes. Cuts variety of meats, fish, poultry; unscrews caps, cuts cord, cardboard, wire screening. It's an ideal all-purpose tool for home or workshop.



- Hot drop-forged, stainless steel
- One blade serrated
- Red baked enamel handle

ITEM NO	FULL LENGTH	CUT LENGTH
<b>WKSR</b>	8" - 204mm	2 5/8" - 66mm

**QUICK-CLIP SPEED CUTTERS**

Stainless steel replaceable blades in ABS plastic, has high impact characteristics.

Contoured design ensures comfort. Quickly cut loose threads and ends of fabric.



- Self-opening spring action.

ITEM NO	FULL LENGTH	CUT LENGTH
<b>W1570</b> (Sharp)	4 3/4" - 121mm	1" - 26mm
<b>W1571</b> (Blunt)	4 3/4" - 121mm	1" - 26mm

**REPLACEMENT PARTS - REPAIR KITS for W1570 & W1571**

- W9317** Repair kit for W1570 (1 pr. of sharp blades, 4 blade screws, 1 spring, 1 stop screw)
- W9318** Repair kit for W1571 (1 pr. of blunt blades, 4 blade screws, 1 spring, 1 stop screw)
- W9328** Repair kit for W1570 (10 replacement sharp blades, 40 blade screws)
- W9329** Contents for W1571 (10 replacement blunt blades, 40 blade screws)

**INDUSTRIAL THREAD CLIPS - SOLID STEEL**

Solid steel, self-opening spring action assures fast effortless cutting. Pivot assembly with Teflon washer allows for adjustments. Fully nickel plated. Quickly cuts loose threads. For industrial use.



ITEM NO.	FULL LENGTH	CUT LENGTH
<b>WTC1</b> (Sharp)	4 3/4" - 121mm	1 1/8" - 28mm
<b>WTC5</b> (Blunt)	4 3/4" - 117mm	1" - 26mm

**REPLACEMENT PARTS - REPAIR KITS FOR WTC1 & WTC5**

**WP1194** Contents for WTC1 & WTC5 (1 each, screw, nut, spring, stop screw)

**INDUSTRIAL THREAD CLIPS - STAINLESS STEEL**

Computer engineered ICE TEMPERED stainless steel, self-opening spring, delrin washer at pivot. 50% lighter than all steel.

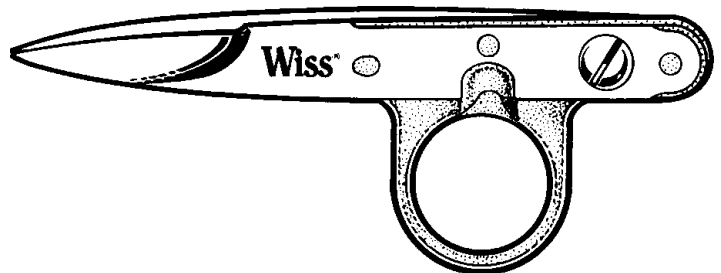

ITEM NO.	FULL LENGTH	CUT LENGTH
<b>WTN1</b> (Sharp)	4 1/2" - 118mm	1 1/4" - 31mm
<b>WTN5</b> (Blunt)	4 1/2" - 114mm	1 1/4" - 31mm



# MUNDIAL



Mundial Four Aces, was established in Porto Alegre, Brazil in 1932. It was founded by cutlery craftsmen from the Solingen area of Germany.

An efficient combination of the latest technology, quality control and complete integration allows Mundial to manufacture quality scissors and shears to meet demanding industrial needs. Quality and economy in each tool.

### INDUSTRIAL FORGED SHEARS - SOLID STEEL

Professional knife-edge, industrial/tailor. Ideal for cutting multiple layers with maximum ergonomic control.



- Hot drop-forged, nickel plated blades and black handles.
- Stay-set pivot assembly.

ITEM NO.	FULL LENGTH	CUT LENGTH
M420-10	10" - 254mm	4 7/8" - 124mm
M420-10LH (LEFT HAND)	10" - 254mm	4 7/8" - 124mm
M422-12	12" - 305mm	6 1/8" - 156mm

### HEAVY DUTY INDUSTRIAL FORGED SHEARS - SOLID STEEL

Professional knife-edge, with heavier and wider blades, European style with **handle rest**. Designed for cutting upholstery, carpet, drapery and multiple layer fabrics.



- Hot drop-forged, nickel plated with black handle.
- Stay-set pivot assembly.

ITEM NO	FULL LENGTH	CUT LENGTH
M429-9	9" - 229mm	4 1/8" - 105mm
M420W	10" - 254mm	4 7/8" - 124mm
M422W	12" - 305mm	6 1/8" - 156mm

### INDUSTRIAL FORGED UTILITY SHEARS SOLID STEEL

Professional knife-edge, elongated shank provides high leverage cutting ability. Used extensively in upholstery, auto/marine and more difficult cutting tasks.



- Hot drop-forged, nickel plated with black handle.
- Stay-set pivot assembly.

ITEM NO.	FULL LENGTH	CUT LENGTH
M456-8	8" - 203mm	3" - 76mm

### BENT TRIMMERS - SOLID STEEL

Professional knife-edge, dressmaker shears for extensive cutting tasks. Ideal for cutting fabrics of all weights. A serrated blade is ideal for cutting fine synthetic fabric/material.



- Hot drop-forged.
- Adjustable bolt/nut pivot assembly.
- 455 series is nickel plated with black handle.
- 454 series is nickel plated with red handle

ITEM NO.	FULL LENGTH	CUT LENGTH
M455-6	6" - 152mm	2 5/8" - 67mm
M455-7	7" - 178mm	3 1/8" - 79mm
M455-8	8" - 203mm	3 5/8" - 92mm
M455-8LH (LEFT HAND)	8" - 203mm	3 5/8" - 92mm
M454-8 (SERRATED)	8" - 203mm	3 5/8" - 92mm
M406-7 (CHROME)	7" - 178mm	3 1/8" - 79mm
M406-8 (CHROME)	8" - 203mm	3 5/8" - 92mm
M406-8LH (CHROME)	8" - 203mm	3 5/8" - 92mm

## Diamond Needle Corp.

GPO BOX 1355 • 159 W 25 St. • New York, NY 10001  
Phone: (212) 929-2277 • (800) 221-5818  
FAX: (212) 242-8882 • (800) 833-3363





# MUNDIAL



## STRAIGHT TRIMMERS - SOLID STEEL

Professional, knife-edge. For general utility purposes, industrial, household, etc., for light pattern cutting.



- Hot drop-forged, nickel plated with black handle.
- Adjustable bolt/nut pivot assembly.

ITEM NO	FULL LENGTH	CUT LENGTH
M355-6	6" - 152mm	2 5/8" - 67mm
M355-7	7" - 178mm	3 1/8" - 79mm
M355-8	8" - 203mm	3 5/8" - 92mm

## PINKING SHEARS - SOLID STEEL

Professional, for use in creating attractive outer edges and finishing seams with ravel resistant zig-zag edge.

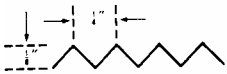

- Hot drop-forged, nickel plated, black handle.
- Bearing pivot - reduces friction and hand fatigue.
- Extra large teeth.

ITEM NO	FULL LENGTH.	CUT LENGTH
M407	7 1/2" - 191mm	2 7/8" - 73mm
M407LH	7 1/2" - 191mm	2 7/8" - 73mm
M409B	9" - 229mm	3 1/2" - 89mm
M410BAA	10" - 254mm	4" - 102mm

## SEWING SCISSORS - SOLID STEEL

Professional, excellent for light to medium snipping and cutting. A general purpose tool for sewing and craft projects. Has one rounded and one sharp blade, ring handle and fully chrome plated.



- Hot drop-forged, fully chrome plated.
- Adjustable screw pivot assembly.

ITEM NO.	FULL LENGTH	CUT LENGTH
M202-5	5" - 127mm	2 1/4" - 57mm
M202-6	6" - 152mm	2 5/8" - 67mm

## EMBROIDERY SCISSORS - SOLID STEEL

Professional, double sharp points and finely tapered blades make these scissors ideal for intricate detail work.



- Hot drop-forged, fully chrome plated, ring handle.
- Adjustable screw pivot assembly.

ITEM NO	FULL LENGTH	CUT LENGTH.
M102-3 1/2	3 1/2" - 89mm	1 1/4" - 32mm
M102-4	4" - 102mm	1 1/2" - 38mm
M102-5	5" - 127mm	2" - 51mm
M102-6	6" - 152mm	2 5/8" - 67mm

# Diamond Needle Corp.

GPO BOX 1355 • 159 W 25 St. • New York, NY 10001  
 Phone: (212) 929-2277 • (800) 221-5818  
 FAX: (212) 242-8882 • (800) 833-3363



### WHITE DIAMOND





# MUNDIAL



## SPECIALTY SCISSORS & SNIPS

### THREAD CLIPS-SOLID STEEL

Self opening, knife-edge and fully chromed. Trims loose threads, ends of fabric, narrow ribbon, etc.

- Hot drop forged, sharp points.

ITEM NO	FULL LENGTH	CUT LENGTH
M301C	4 1/2" - 114mm	1" - 26mm



### TAILOR POINT - SOLID STEEL

Professional model, extra sturdy blades with ring handle. For light tailoring tasks.

- Hot drop-forged, nickel plated with black handle.
- Adjustable screw pivot assembly.

ITEM NO	FULL LENGTH	CUT LENGTH
M275-5	5" - 127mm	2" - 51mm



### BUTTONHOLE SCISSORS - SOLID STEEL

Adjustable screw sets the length of cut. Specifically designed for cutting precision button holes.

- Hot drop forged, fully chrome plated, ring handle.
- Adjustable screw pivot assembly.

ITEM NO.	FULL LENGTH	CUT LENGTH
M252	4 1/2" - 114mm	adjustable



### SPECIALTY EMBROIDERY SCISSORS - SOLID STEEL

Finely tapered curved short blades with extra sharp points. Ideal for intricate work. Often called scherenschnitte or turmspitze or cuticle.

- Hot drop forged, fully chrome plated.
- Adjustable screw pivot assembly.

ITEM NO.	FULL LENGTH	CUT LENGTH
M701	3 1/2" - 89mm	7/8" - 22mm
M705	3 1/2" - 89mm	7/8" - 22mm

(705 HAS EXTRA NARROW BLADES)



### APPLIQUE SCISSORS - SOLID STEEL

For trimming applique. Pelican bill, **offset blades**, ring handle.

- Hot drop-forged, fully chrome plated.
- Adjustable screw pivot assembly.

ITEM NO	FULL LENGTH	CUT LENGTH
M585	6" - 152mm	1 3/8" - 35mm



# Diamond Needle Corp.

GPO BOX 1355 • 159 W 25 St. • New York, NY 10001  
 Phone: (212) 929-2277 • (800) 221-5818  
 FAX: (212) 242-8882 • (800) 833-3363





# MUNDIAL



## SPECIALTY SCISSORS & SNIPS

### POCKET SCISSORS - SOLID STEEL

Blunt safety points, handy, just throw'em in your pocket.

- Hot drop-forged, fully chrome plated.
- Adjustable screw pivot assembly.

ITEM NO	FULL LENGTH	CUT LENGTH
M520-4	4" - 102mm	1 3/4" - 44mm



### NOSE & EAR SCISSORS - SOLID STEEL

Safety rounded blunt points. Curved blades, ring handle, fully chromed, hot drop-forged.

- Adjustable screw pivot assembly.

ITEM NO.	FULL LENGTH	CUT LENGTH
M941	4" - 102mm	1 1/2" - 38mm



### MUSTACHE SCISSORS - SOLID STEEL

Finely tapered blades for detailed trimming. Hot drop-forged, fully chromed, ring handle.

- Adjustable screw pivot assembly.

ITEM NO.	FULL LENGTH	CUT LENGTH
M944	4" - 102mm	1 1/2" - 38mm



### NAIL SCISSORS - SOLID STEEL

Heavy pattern, curved blades, ideal for embroidery work. Hot drop-forged, fully chromed, ring handle.

- Adjustable screw pivot assembly.

ITEM NO.	FULL LENGTH	CUT LENGTH
M704	4" - 102mm	1 1/2" - 38mm



### KITCHEN/POULTRY SHEARS

Poultry, fowl shears. Hot drop-forged, fully chrome plated

- Barrel spring-action (cuts poultry/fowl bones).

ITEM NO	FULL LENGTH	CUT LENGTH
M715	10 1/2" - 267mm	3" - 76mm



### STAINLESS (Lightweight)

An indispensable tool. Shears, bottle opener, screwdriver, and jar cap gripper. All-purpose, with take-apart blades for easy thorough cleaning. They cut almost anything.

ITEM NO	FULL LENGTH	CUT LENGTH
M666	8" - 203mm	2" - 51mm



# Diamond Needle Corp.

GPO BOX 1355 • 159 W 25 St. • New York, NY 10001  
 Phone: (212) 929-2277 • (800) 221-5818  
 FAX: (212) 242-8882 • (800) 833-3363



WHITE DIAMOND



# MUNDIAL



## CUSHION SOFT STAINLESS LIGHTWEIGHT SHEARS

### ERGONOMIC & AMBIDEXTROUS

Ideal for heavy use, and for people experiencing weakness in the hand.

# NEW!

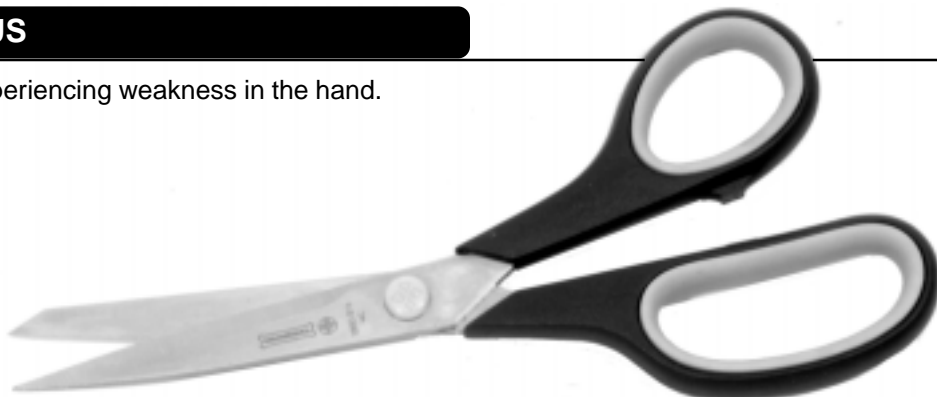

Knife-edge, adjustable pivot assembly.

Enlarged finger bows and soft-touch inserts for comfortable non-slip grip. Micro-serrated blade (except Pinking Shears) provides maximum control in cutting even the most delicate, silky fabrics.

ITEM NO.	DESCRIPTION	FULL LENGTH	CUT LENGTH
M1860-1	Dressmaker	8" - 203mm	3 5/8" - 92mm
M1890-1	Professional Dressmaker	9" - 229mm	4 1/8" - 105mm
M1865-1	Pinking Shears	7 1/2" - 191mm	2 7/8" - 73mm

## PREMIUM STAINLESS LIGHTWEIGHT SCISSORS & SHEARS

Cutlery quality stainless blades with comfortable matte black polypropylene handles to prevent slippage. Adjustable pivot assembly protected by red button. Knife-edge. Resharpenable.

### DRESSMAKER SHEARS

ITEM NO.	FULL LENGTH	CUT LENGTH
M660	8" - 203mm	3 5/8" - 92mm
M661LH (LEFT HAND)	8" - 203mm	3 5/8" - 92mm
M690	9" - 229mm	4 1/8" - 105mm



### PINKING SHEARS

• Ravel resistant zig-zag edge cut.



ITEM NO.	FULL LENGTH	CUT LENGTH
M665	7 1/2" - 191mm	2 7/8" - 73mm



# Diamond Needle Corp.

GPO BOX 1355 • 159 W 25 St. • New York, NY 10001  
Phone: (212) 929-2277 • (800) 221-5818  
FAX: (212) 242-8882 • (800) 833-3363





# MUNDIAL



## PREMIUM STAINLESS LIGHTWEIGHT SCISSORS & SHEARS

Cutlery quality stainless blades with comfortable matte black polypropylene handles to prevent slippage. Adjustable pivot assembly protected by red button. Knife-edge. Resharpenable.

### STRAIGHT TRIMMERS

For light duty cutting and trimming.

ITEM NO.	FULL LENGTH	CUT LENGTH
M662	7" - 178mm	3 1/4" - 83mm



### EMBROIDERY SCISSORS

Double sharp points.

ITEM NO.	FULL LENGTH	CUT LENGTH
M668	4 1/2" - 114mm	1 3/8" - 35mm
M664	5 1/2" - 140mm	1 7/8" - 48mm



### BARBER/LINGERIE SHEARS

Micro serrated bottom blade.  
Ideal for cutting fine hair, fabrics and threads.

ITEM NO.	FULL LENGTH	CUT LENGTH
M663	7 1/2" - 191mm	2 3/4" - 70mm



### POCKET/SAFETY POINT SCISSORS

Safety blunt points, ring handle. Handy and durable.

ITEM NO.	FULL LENGTH	CUT LENGTH
M667	5" - 127mm	1 1/2" - 38mm



### THREAD CLIP

Premium contoured plastic handle with high impact characteristics. Lightweight.

- Spring return action
- Comfort molded grip

ITEM NO.	FULL LENGTH	CUT LENGTH
M601	4 3/4" - 121mm	1 1/4" - 32mm



# Diamond Needle Corp.

GPO BOX 1355 • 159 W 25 St. • New York, NY 10001  
Phone: (212) 929-2277 • (800) 221-5818  
FAX: (212) 242-8882 • (800) 833-3363



WHITE  
DIAMOND

# **WOLFF *Twice As Sharp*** **PROFESSIONAL SCISSORS/SHEARS SHARPENER**

**TWICE AS SHARP** is a USA manufactured sharpener guaranteed to give you professional sharpening and reconditioning results. This no-maintenance machine comes packed with a 1/5 HP condenser run motor, precision double sealed ball bearings. The free moving arms have double sealed Rulon bearings, meaning no maintenance required.

## KEY FEATURES

- Full 1/2" wide sharpening wheel, 100 grit fine grain friable aluminum oxide.
- Grinding length is 14" without reclamping, and 28" with extra long arms.
- Holds all types and sizes, including pinking shears.
- Angles are fully adjustable from 0- 57 degrees.
- Comes complete with safety glass, breathing mask, lubricant, hone wheel dresser, eye shields, hex wrench and instruction manual (easy to read/well illustrated) and instructional video.

**MODEL A-1** (110V, 60 Cy., 1 Ph.)

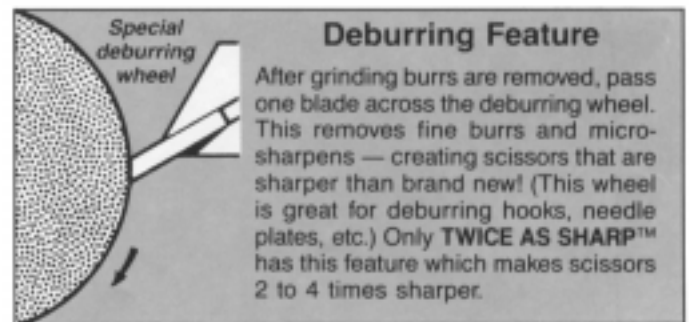
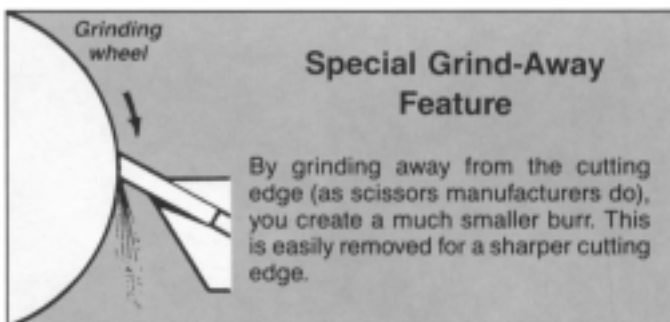
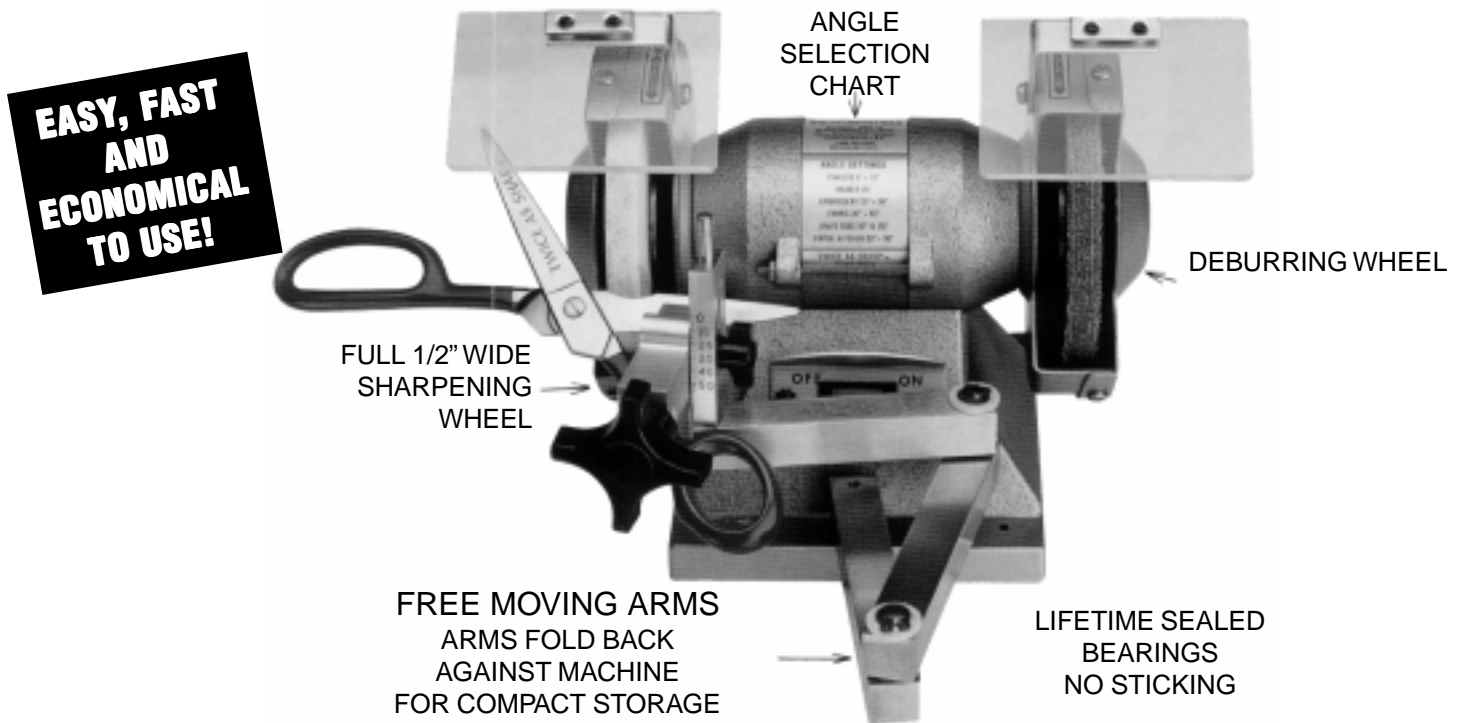

**Diamond Needle Corp.**

GPO BOX 1355 • 159 W 25 St. • New York, NY 10001  
 Phone: (212) 929-2277 • (800) 221-5818  
 FAX: (212) 242-8882 • (800) 833-3363





# GOLD SEAL



Since 1927 GOLD SEAL has been filling the need for fine industrial cutting instruments. Scissors and shears are designed, engineered and manufactured in the USA to satisfy the demand for continuous use. GOLD SEAL patented and introduced the "Ball Bearing" thread nipper which has become the recognized standard of the industry. GOLD SEAL also introduced the "Knife Edge" grind for shears, scissors and thread nippers.

All GOLD SEAL shears, scissors and thread nippers are made of special high carbon steel, hot drop-forged and then hardened and tempered to exact specifications for outstanding durability and edge retention. After assembly, each pair is individually adjusted and subjected to demanding tests for cutting abilities.

## BALL BEARING NIPPERS

Gold Seal "precision" made thread nippers are used in many industrial applications. They are fast, efficient and convenient for any light cutting operation. The nipper fits the hand comfortably leaving fingers free to handle the material.

"Ball Bearing" construction for smoother, easier operation and increases the life of the nipper.

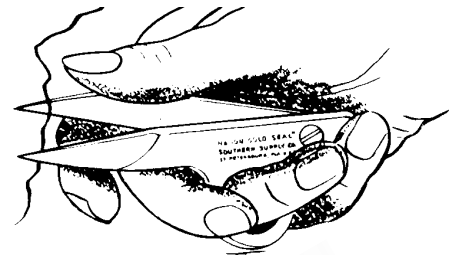

Thread Nippers are "worn" in hand leaving fingers free to handle material.

## STANDARD SIZE



ITEM NO.	FINISH	FULL LENGTH	CUT LENGTH
104N	Nickel	4 1/2" - 114mm	1 1/4" - 32mm
104SC	Satin chrome	4 1/2" - 114mm	1 1/4" - 32mm
104BC	Bright chrome	4 1/2" - 114mm	1 1/4" - 32mm
104NKE	Nickel/Knife edge	4 1/2" - 114mm	1 1/4" - 32mm
104SCKE	Satin chrome/Knife edge	4 1/2" - 114mm	1 1/4" - 32mm
104BCKE	Bright chrome/Knife edge	4 1/2" - 114mm	1 1/4" - 32mm
104SCPB	Satin chrome/Blunt points/Knife edge	4 1/2" - 114mm	1 1/4" - 32mm
104NCB	Nickel/Curved blades	4 1/2" - 114mm	1 1/4" - 32mm
104SS	Stainless steel	4 1/2" - 114mm	1 1/4" - 32mm
104SSKE	Stainless steel/Knife edge	4 1/2" - 114mm	1 1/4" - 32mm

## KING SIZE



ITEM NO.	FINISH	FULL LENGTH	CUT LENGTH
104LN	Nickel	5" - 127mm	2" - 51mm
104LNKE	Nickel/Knife edge	5" - 127mm	2" - 51mm
104LSCP	Satin chrome/Blunt points	5" - 127mm	2" - 51mm
104LSCBKKE	Satin chrome/Blunt points/Knife edge	5" - 127mm	2" - 51mm

# Diamond Needle Corp.

GPO BOX 1355 • 159 W 25 St. • New York, NY 10001  
Phone: (212) 929-2277 • (800) 221-5818  
FAX: (212) 242-8882 • (800) 833-3363



NOT RESPONSIBLE FOR TYPOGRAPHICAL ERRORS.

## POLYMER COATED

Constructed with special blue polymer coating having unique properties and advantages:

- Tough polymer coating will not react to acids and salt in skin.
- Very low coefficient of friction, thread and debris slides off nipper more readily and improves ride.
- Superior corrosion resistance - will not migrate under coating.
- Eliminates contact allergies - prevents dermatitis.
- High visibility color - easy to locate.

# NEW!



ITEM NO.	DESCRIPTION	FULL LENGTH	CUT LENGTH
<b>104X</b>	Polymer	4 1/2" - 114mm	1 1/4" - 32mm
<b>104XKE</b>	Polymer/Knife edge	4 1/2" - 114mm	1 1/4" - 32mm

## NIPPER HARDWARE (replacement parts)

Note: each part, as indicated in diagram can be ordered individually, by part number.

ITEM NO.	DESCRIPTION
<b>104N10</b>	Main bolt
<b>104N15</b>	Stop screw
<b>104N20</b>	Main spring
<b>104N25</b>	Coil spring for stainless ball
<b>104N30</b>	Fiber insert locknut
<b>104N35</b>	Stainless ball
<b>104N40</b>	Ball bearing in retainer

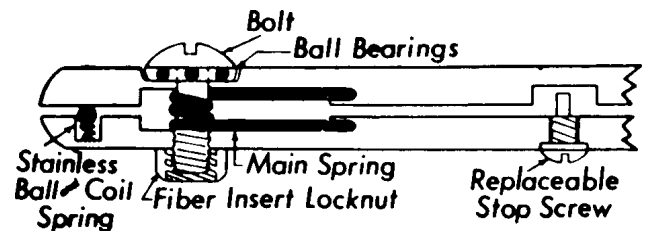

## HONES - GOLD SEAL

Ceramic hones produce the finest edge on knife edge shears. A few passes on the cutting edge will restore the edge and eliminate more costly resharpening services.

ITEM NO.	DESCRIPTION	FULL LENGTH
<b>99N</b> (Brown)	Triangular	6" x 1/2" sides
<b>100N</b> (White)	Triangular	6" x 1/2" sides
<b>101N</b> (Brown)	Round w/handle	12" x 5/16" diameter



## HEAVY DUTY BENT TRIMMERS - KNIFE EDGE

Rugged, overbuilt for the heaviest service. Used by tailors, carpeters, upholsters, shoe-makers, etc.

- Hot drop-forged, satin chromed, black handles.
- Oversized finger bow for comfort
- Thicker, heavier blades

ITEM NO.	FULL LENGTH	CUT LENGTH
<b>172KE10</b>	10" - 254mm	4 3/4" - 121mm
<b>172LHKE10 (LEFT HAND)</b>	10" - 254mm	4 3/4" - 121mm
<b>180KE12</b>	12" - 305mm	6" - 152mm



## BENT TRIMMER - KNIFE EDGE

Professional, dressmaker shears for cutting fabric of all weights and multiple layers. Bent pattern facilitates cutting material on flat surfaces.

- Hot drop-forged, fully satin chromed over nickel, rust/stain resistant.

ITEM NO	FULL LENGTH	CUT LENGTH
<b>171KE6</b>	6" - 152mm	2 5/8" - 67mm
<b>171KE7</b>	7" - 178mm	3 1/4" - 83mm
<b>171LHKE7 1/2 (LEFT HAND)</b>	7 1/2" - 191mm	3 5/8" - 92mm
<b>171KE8</b>	8" - 203mm	3 7/8" - 98mm
<b>171LHKE8 (LEFT HAND)</b>	8" - 203mm	4" - 102mm
<b>171KE9</b>	9" - 229mm	4 3/8" - 111mm
<b>171KE10</b>	10" - 254mm	4 3/4" - 121mm
<b>171KE12</b>	12" - 305mm	5 1/2" - 130mm



## STRAIGHT TRIMMERS - KNIFE EDGE

General purpose shears, for industrial, household, utility or any sewing application where bent trimmers are not practicable.

- Hot drop-forged, fully satin chromed over nickel, rust/stain resistant.

ITEM NO	FULL LENGTH.	CUT LENGTH
<b>170KE6</b>	6" - 152mm	2 3/4" - 70mm
<b>170KE7</b>	7" - 178mm	3 1/4" - 83mm
<b>170KE8</b>	8" - 203mm	3 7/8" - 98mm
<b>170KE9</b>	9" - 229mm	4 3/8" - 111mm
<b>170KE10</b>	10" - 254mm	5 3/8" - 137mm



## POULTRY SHEARS - KNIFE EDGE

Rounded, blunt points, run smoothly, cut cleanly and last a long time.

- Hot drop-forged cutlery steel that is fully hardened and tempered.
- Fully satin chromed over nickel, rust/stain resistant, will not peel
- Bolt pivot with locking nut - adjustable.

ITEM NO	FULL LENGTH.	CUT LENGTH
<b>190P8 (High Leverage)</b>	8" - 203mm	2 1/4" - 57mm
<b>191P9</b>	8" - 203mm	3 1/4" - 83mm
<b>170PKE9 (Sharp Points)</b>	9" - 229mm	3 7/8" - 98mm





## HEAVY DUTY UTILITY TRIMMERS - KNIFE EDGE

**Longer handles**, heavier construction provide extra leverage and strength for tough cutting tasks. These well balanced shears are ideal for multiple applications, i.e., carpet, garment, food processing, upholstery, leather, etc.

- Hot drop-forged, fully satin chromed over nickel, rust/stain resistant.

ITEM NO.	FULL LENGTH	CUT LENGTH
<b>176KE8</b>	8" - 203mm	3" - 76mm
<b>186KE8</b> (Larger Finger Bow)	8" - 203mm	3" - 76mm



## RUG/UTILITY SHEARS - KNIFE EDGE

Specially designed shears with longer handles and elongated shank that provides extra leverage. These patterns are suitable for close work and tight places. They have wide applications in industries such as: carpet, garment, food processing, upholstery, shoe, and leather goods, etc.

ITEM NO.	FULL LENGTH	CUT LENGTH
<b>179CHKE7 1/2</b> (Lighter Pattern)	7 1/2" - 191mm	2 3/4" - 70mm
<b>176CHKE8</b> (Offset Handle)	8" - 203mm	3" - 76mm
<b>170PCB8</b> (Curved Blades)	8" - 203mm	3" - 76mm
<b>170LHPCB7</b> (Left Hand)	7 1/2" - 191mm	2 3/4" - 70mm



179CHKE7 1/2



170PCB8

## BIG SIX TRIMMER

Tailor point scissors, but with a regular handle.

- Large bows, double sharp points.

<b>178KE6 1/2</b>	6 1/2" - 165mm	2 1/2" - 64mm
-------------------	----------------	---------------



## UTILITY SCISSORS

Longer shank, ring handle, very fine sharp points and tapered blades.

- Hot drop-forged, fully nickel plated.
- Increased leverage.

ITEM NO.	FULL LENGTH	CUT LENGTH
<b>157KE5</b>	5" - 127mm	1 5/8" - 41mm



## EMBROIDERY SCISSORS - KNIFE EDGE

Double sharp points and tapered blades, designed for light work requiring close detail.

ITEM NO.	FULL LENGTH	CUT LENGTH
<b>154KE4</b>	4" - 102mm	1 1/2" - 38mm
<b>154KE5</b>	5" - 127mm	2 1/8" - 54mm



## The BELMONT Alternative...

Belmont scissors and shears are manufactured with the same high standards and methods employed by the leading brands. They are designed to perform their specific tasks with excellence.

With an eye on the future Belmont continues to seek production economies and efficiencies that will insure exceptional values. We source the best available products from all over the country, even around the world. We carry the widest variety to fit almost every cutting application and give you more for your money.

Belmont continues to carry styles and patterns that have been discontinued by the big name manufacturers.

### EXTRA LARGE BENT TRIMMERS - ITALY

Finest quality forged steel, precision ground, thru-tempered and hardened to insure excellent performance. Constructed with large contoured comfort handle with a thumb rest for ease of cutting on flat surfaces.

- Hot drop-forged, nickel plated with black handle.
- **Nobody makes them bigger.**
- Self-adjusting pivot with **rest stand**.

ITEM NO.	FULL LENGTH	CUT LENGTH
249/13	13" - 330mm	6 1/4" - 159mm
249/14	14" - 356mm	6 7/8" - 175mm



### HEAVY DUTY BENT TRIMMERS - USA

Fine quality and durable shears that are primarily used by tailors, upholsterers auto/marine, and textile cutting applications.

- Hot drop-forged, nickel plated with black handle.
- Adjustable bolt/nut pivot assembly.

ITEM NO.	FULL LENGTH	CUT LENGTH
580/10	10" - 254mm	4 3/4" - 121mm
580/12	12" - 305mm	6" - 152mm



### BENT TRIMMERS - USA

The preferred shears for continuous use. These USA manufactured shears are designed for cutting on flat surfaces. Widely used in the textile trade for cutting multiple layers and also for trimming applications.

- Hot drop-forged, nickel plated with black handle.
- Adjustable bolt/nut pivot assembly.

ITEM NO.	FULL LENGTH	CUT LENGTH
571/6	6" - 152mm	2 5/8" - 67mm
571/7	7" - 178mm	3 1/4" - 83mm
571/7 1/2LH (Left Hand)	7 1/2" - 191mm	3 5/8" - 92mm
571/8	8" - 203mm	3 7/8" - 98mm
571/9	9" - 229mm	4 3/8" - 111mm



**PATTERN & DESIGNER SHEARS - USA**

Heavy duty, easy to use. Constructed with high quality carbon steel, extra long shank and heavy blades. Provides superior leverage for cutting pattern board and other tough materials.

- Hot drop-forged, nickel plated with black handle.
- Knife edge for ease in cutting.
- Blade bottom beveled for controlled cutting.
- Adjustable bolt/nut pivot assembly.



ITEM NO.  
**8TU**

FULL LENGTH  
12" - 305mm

CUT LENGTH  
3" - 76mm

**INDUSTRIAL UTILITY SHEARS - USA**

Specially designed shears with **elongated** shank for maximum cutting leverage. Extra leverage is also provided by the increased relative length, shape and handle size. Used extensively in upholstery, auto/marine, poultry processing, florist and any other difficult cutting task.

**STANDARD UTILITY SHEARS - USA**

Quality high carbon forged steel with **elongated shank** and **regular handle**.

- Hot drop-forged, nickel plated with black handle.
- Adjustable bolt/nut pivot assembly.

ITEM NO.  
**576/8**

FULL LENGTH  
8" - 216mm

CUT LENGTH  
3" - 76mm



**ERGONOMIC UTILITY SHEARS - USA**

Quality **high carbon forged steel** similar to item 576/8 but with **longer and larger finger bow**. Enough finger space so that gloves can be worn. Recommended for the very tough jobs.

- Hot drop-forged, full satin chrome over nickel.
- Adjustable bolt/nut pivot assembly.



ITEM NO.  
**576E/9**

FULL LENGTH  
8 3/4" - 222mm

CUT LENGTH  
3" - 76mm

## ERGONOMIC STAINLESS UTILITY SHEARS - USA

Cutlery grade quality stainless steel construction with **elongated shank** for extra leverage. **Ice Tempered**, a special tempering process that doubles cutting edge life.

- Ice tempered, stainless, commercial finish.
- Adjustable bolt/nut pivot assembly.

ITEM NO.	FULL LENGTH	CUT LENGTH
8.5HL	8" - 216mm	3" - 76mm



## ERGONOMIX STAINLESS CURVED HANDLE UTILITY SHEARS - USA

Cutlery grade quality stainless steel constructed with **elongated shank** and a **curved handle** for extra leverage and reduced hand fatigue. **Ice Tempered**, to double cutting edge life.

- Ice tempered, stainless, commercial finish.
- Adjustable bolt/nut pivot assembly.

ITEM NO.	FULL LENGTH	CUT LENGTH
502HU	8" - 216mm	3" - 76mm



## ERGONOMIC CURVED HANDLE UTILITY SHEARS - USA

Quality high carbon forged steel, same as item 576E/9 but with **longer and larger finger bow**, plus a **curved handle**. This combination produces extra high leverage, reduces hand fatigue and has plenty of finger room.

- Hot drop-forged, full satin chrome over nickel.
- Adjustable bolt/nut pivot assembly.

ITEM NO.	FULL LENGTH	CUT LENGTH
576HU	8 3/4" - 222mm	3" - 76mm



## STANDARD UTILITY - RUG SHEARS - USA

Quality high carbon forged steel, heavy duty shears with **offset handle** for trimming pile and cutting in tough, hard to reach places.

- Hot drop-forged, nickel plated with black handle.
- Adjustable bolt/nut pivot assembly.

ITEM NO.	FULL LENGTH	CUT LENGTH
576/CH8	8" - 216mm	2 7/8" - 73mm



**SPECIALTY SCISSORS & SNIPS**

**OFFSET ANGLE EMBROIDERY SCISSORS**

Specially designed for close detail trimming work. Also ideal for making cuts under presser feet and other tight places.

- Hot drop-forged, fully chrome plated.
- Double sharp points, ring handle.

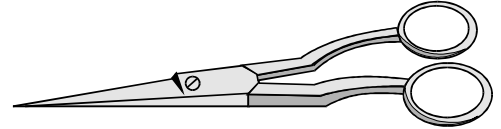

<u>ITEM NO.</u>	<u>FULL LENGTH</u>	<u>CUT LENGTH</u>
<b>584/6</b> (Italy)	6" - 152mm	1 3/4" - 44mm

**CURVED BLADE APPLIQUE SCISSORS**

Finely tapered **curved blades** with extra sharp points. Ideal for intricate and detailed work.

- Hot drop forged, fully nickel plated, ring handle.

<u>ITEM NO.</u>	<u>FULL LENGTH</u>	<u>CUT LENGTH</u>
<b>290/4I</b> (Italy)	4" - 102mm	2" - 51mm
<b>290/5I</b> (Italy)	5" - 127mm	2 1/8" - 54mm
<b>290/5</b> (USA)	5" - 127mm	2 1/8" - 54mm



**LARGE RING VERSION**

<b>390/4</b> (Italy)	4" - 102mm	2" - 51mm
----------------------	------------	-----------



**LOW PRICE!**

All steel, **disposable** (Resharpen or throw-away)

<u>ITEM NO.</u>	<u>FULL LENGTH</u>	<u>CUT LENGTH</u>
<b>290/4P</b> (Pakistan)	4" - 102mm	2" - 51mm
<b>290/5P</b> (Pakistan)	5" - 127mm	2 1/8" - 54mm

**SPECIALTY APPLIQUE SCISSORS/PERSONAL GROOMING**

Finely tapered **curved blades** for detailed trimming and embroidery work.

- Hot drop-forged, fully chromed, ring handle.

<u>ITEM NO.</u>	<u>FULL LENGTH</u>	<u>CUT LENGTH</u>
<b>696/3 1/2</b> (Italy)	3 1/2" - 89mm	1" - 25mm

**SPECIALTY EMBROIDERY SCISSORS**

Finely tapered **short narrow curved blades** for intricate work.

<u>ITEM NO.</u>	<u>FULL LENGTH</u>	<u>CUT LENGTH</u>
<b>634/3 1/2</b> (Fine) Italy	3 1/2" - 89mm	3/4" - 19mm
<b>628/3 1/2</b> (Extra fine) Italy	3 1/2" - 89mm	5/8" - 16mm



**EMBROIDERY SCISSORS**

Double sharp points and finely tapered blades make these scissors ideal for intricate detail work.

<u>ITEM NO.</u>	<u>FULL LENGTH</u>	<u>CUT LENGTH</u>
<b>735/5I</b> (Italy)	5" - 127mm	2" - 51mm

**LOW PRICE!**

All steel **disposable** (resharpen or throw-away)

<u>ITEM NO.</u>	<u>FULL LENGTH</u>	<u>CUT LENGTH</u>
<b>735/5P</b> (Pakistan)	5" - 127mm	2" - 51mm



**STORK EMBROIDERY SCISSORS**

Double sharp points and finely tapered blades for intricate work. Delicate enough to cut a baby's nails... able to trim the finest threads.

- Hot drop-forged, gold plated with chrome blades, ring handle.

<u>ITEM NO.</u>	<u>FULL LENGTH</u>	<u>CUT LENGTH</u>
<b>555G</b>	3 1/2" - 89mm	7/8" - 22mm



**SAFETY POCKET SCISSORS**

Handy, durable enough for many cutting jobs. Just throw 'em in your pocket.

- Hot drop-forged, fully nickel plated, ring handle.
- Double blunt safety points.

<u>ITEM NO.</u>	<u>FULL LENGTH</u>	<u>CUT LENGTH</u>
<b>360/5</b>	5" - 127mm	2 1/8" - 54mm



**ELECTRICIAN'S/UTILITY SCISSORS**

Quality forged steel construction. Handy tool for cutting insulation, electrical wire, harness ties, etc.

- Hot drop-forged, full commercial finish.
- Double sharp points, ring handle.

<u>ITEM NO.</u>	<u>FULL LENGTH</u>	<u>CUT LENGTH</u>
<b>575E</b>	5" - 127mm	1 3/4" - 44mm



## MULTI-PURPOSE SHEARS

Specially designed shears that will cut almost anything, even a penny. Fully stainless steel with plastic handle. A serrated bottom blade and a unique bent handle.

ITEM NO.	FULL LENGTH	CUT LENGTH
420/7	7 3/8" - 187mm	1 5/8" - 41mm



## THREAD NIPPERS

### STAINLESS STEEL THREAD CLIP - USA

Computer engineered "ICE TEMPERED" stainless steel, self-opening spring action, delrin washer at pivot, 50 % lighter than all steel.

ITEM NO.	FULL LENGTH	CUT LENGTH
415N	4 1/2" - 118mm	1 1/4" - 32mm



### DELUXE ECONOMY THREAD CLIP

Lightweight, sharp with replaceable steel blades.

ITEM NO.	FULL LENGTH	CUT LENGTH
TC200	4 3/4" - 121mm	1 1/4" - 32mm



### TC201 REPAIR KIT

Contents one (1) pair of blades, four (4) blade screws and one (1) spring

### DISPOSABLE ECONOMY THREAD CLIP

*Lightweight with sharp steel blades.*

ITEM NO.	FULL LENGTH	CUT LENGTH
TC100	4" - 102mm	1 1/4" - 32mm

Stainless, pressed steel, sharp points.

ITEM NO.	FULL LENGTH	CUT LENGTH
TC105	4 1/4" - 121mm	1 1/8" - 29mm



Fiskars has a tradition of quality that dates back to 1649 when they began manufacturing in the village of Fiskars near Helsinki, Finland.

In 1960 Fiskars revolutionized the scissors and shears industry. After years of intensive research and testing, Fiskars introduced lightweight, orange handled scissors with stainless steel blades that were efficient, long-lasting molded handles conformed to the contour of the hand.

Today, Fiskars continues with the same high standards in improving comfort and performance, with innovative, ergonomic and superior quality products.

**SOFTOUCH SCISSORS & SHEARS - ERGONOMIC**

Oversized cushion grip handle, easy action spring gently opens blades after each cut and reduces fatigue. Contains an adjustable screw for blade tension modification.

- Oversized cushion grip handle.
- Easy-slide lock keeps blades closed
- Ambidextrous



ITEM NO.	FULL LENGTH	CUT LENGTH
F9911	10" - 254mm	3 1/8" - 79mm
F9921	5" - 127mm	1 5/8" - 41mm

**STAINLESS BENT TRIMMERS**

**FISKARS/ORANGE HANDLE**

Most popular multi-purpose shears. Great for cutting practically anything from paper to poultry. Easy cutting on flat surfaces.

- Adjustable stainless screw pivot.
- Precision blade alignment.
- Ergonomically designed fiberglass handle.

ITEM NO.	FULL LENGTH	CUT
F9451-8	8" - 203mm	3 7/8" - 98mm
F9450-8LH	8" - 203mm	3 7/8" - 98mm
F9441-9	9" - 229mm	4 1/8" - 105mm



**FISKARS/DURA-SHARP**

Stainless steel blades are precision ground to maintain their edge. Molded handles for a firm, comfortable grip. This 8" bent trimmer can be used for an unlimited number of tasks. **For left or right handed use.**

- Adjustable rivets allow you to adjust the tension.

ITEM NO.	FULL LENGTH	CUT LENGTH
F1000-8	8" - 203mm	3 1/2" - 89mm





**SOFTGRIP & EXECUTIVE SHEARS**

**New!** Midsize multi-purpose shears featuring a soft, long-wearing cushion material bonded to the handle for increased comfort and a sure grip.

- Ambidextrous.
- Adjustable screw pivot.

ITEM NO.	FULL LENGTH	CUT LENGTH
F9880-8	8" - 203mm	3 7/8" - 98mm



**PINKING SHEARS**

For finishing the edges and seams of cloth and other material.

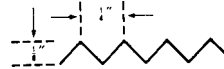

ITEM NO.	FULL LENGTH	CUT LENGTH
F9445-9	9" - 229mm	3" - 76mm



**SHORTCUT SNIPS**

Great for snipping and trimming. Left or right handed.

ITEM NO.	FULL LENGTH	CUT LENGTH
F9495	5" - 127mm	1" - 25mm



**SPECIALTY ROTARY/UTILITY CUTTER**

Razor sharp, cut nearly effortlessly through multi-layers of fabric. Cutter accepts 10 styles of blades that mount on either side for left or right handed use.

- Contoured handle for comfort.
- Convenient loop handle for sure grip.
- Easy to access blade lever and release button.

ITEM NO.	BLADE SIZE	BLADE STYLE
F9521	45mm	Straight



**ROTARY BLADES**

ITEM NO.	BLADE SIZE	BLADE STYLE
F9531	45mm	Straight
F9539	45mm	Scallop

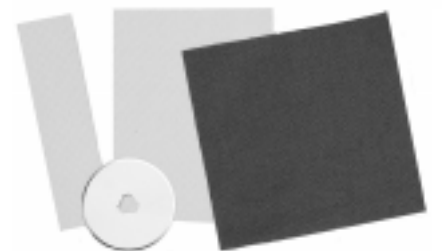

**SELF-HEALING CUTTING MATS**

Two-color grid mats are reversible with durable three-layer construction. Surface layers are self-healing and tough inner layer resists penetration.

ITEM NO.	MAT SIZE (IN")	MAT SIZE (METRIC)
F8621	18" X 24"	457mm X 610mm
F8631	24" X 36"	610mm X 914mm





## STAINLESS STEEL MESH SAFETY GLOVES

Chainex metal mesh safety gloves are manufactured in compliance with the major international safety standards - **UL, CSA, EC,GS**. Chainex gloves provide a great measure of safety for many jobs with meat, fish, textiles, leather, cardboard, plastic and metal. The gloves offer a high level of protection against cuts and stab wounds with maximum comfort for flexible hand movement.

- Lightweight, AISI 316 stainless steel links.
- Adjustable nylon straps with snap fasteners.
- Complies with USDA requirements.
- Three (3) and Five (5) finger styles.
- Five (5) finger glove is reversible/ambidextrous.
- Instructions, maintenance, cleaning/storage information included.

**CHAINEX GLOVE CHAINMAIL**  
 Stainless steel AISI 316L  
 Welded rings  
 External diameter of the rings: 4mm  
 Wire diameter: 0.5mm

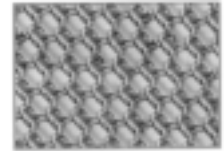

### THREE FINGER GLOVES

ITEM NO.      DESCRIPTION

**MG300XS**      Extra Small - Left  
**MG300XSA**    Extra Small - Right

**MG300S**        Small            - Left  
**MG300SA**      Small            - Right

**MG300M**      Medium         - Left  
**MG300MA**     Medium         - Right

**MG300L**        Large            - Left  
**MG300LA**      Large            - Right

**MG300XL**     Extra Large    - Left  
**MG300XLA**    Extra Large    - Right



### FIVE FINGER GLOVES

ITEM NO      DESCRIPTION

**MG500XS**      Extra Small

**MG500S**        Small

**MG500M**      Medium

**MG500L**        Large

**MG500XL**     Extra Large

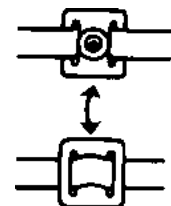

Reversible five finger gloves, as indicated by pictogram, easily switched from left to right hand by simply turning the glove and fastener inside out.

## ULTRA-LAMEX/CHAINEX APRONS

**ULTRA-LAMEX** aprons, made of aluminum plates, are strong and flexible. **CHAINEX** chainmail is tough and very comfortable.

Both types of aprons provide safety for the upper part of the body and are designed not to hamper movement. The aprons are fitted with a belt and wide adjustable, detachable straps, specially designed to prevent fatigue.

- Rectangular aluminum plates (35X19mm)
- Stainless steel rings, AISI 316L
- Chainmail made from welded rings, stainless steel AISI 316L wire thickness is 0.8mm with internal diameter of 5.5mm.

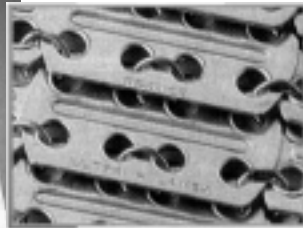











### ULTRA-LAMEX APRONS

ITEM NO.	DESCRIPTION
UL24X22	24"X22" For persons under 5'5"
UL30X22	30"X22" For persons over 5'5"

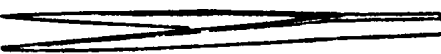
### CHAINEX APRONS

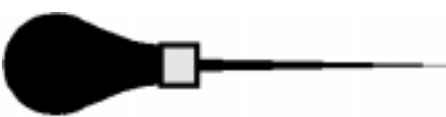
ITEM NO	DESCRIPTION.
CH24X22	24"X22" For person under 5'5"
CH30X22	30"X22" For persons over 5'5"

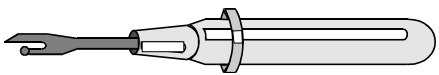
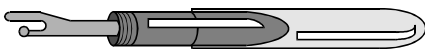
# ASSORTED HELPFUL TOOLS

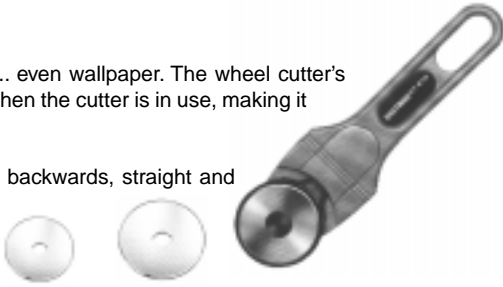
<p>SELF-LOCKING TWEEZER #TWE15 (4-1/2") #TWE16 (6-3/4")</p>  <p>Stainless steel.</p>	<p>STRAIGHT 4" TWEEZER W/HOOK #TWE3</p>  <p>Stainless steel Ribbed points, hook at end</p>	<p>DELUXE 5" BENT TWEEZER #TWE4</p>  <p>Precision points, stainless steel.</p>
<p>DELUXE 6" BENT TWEEZER #TWE6</p>  <p>Has alignment pin. Precision points, Picks up the finest threads.</p>	<p>STAINLESS 6" TWEEZER #TWE7</p>  <p>Bent tweezer Precision points Forged stainless steel</p>	<p>STRAIGHT 6" TWEEZER #TWE8</p>  <p>Stainless steel Precision points, pinpoint accuracy</p>
<p>SCISSOR TYPE 6" CLAMPING PLIERS #EW166</p>  <p>Stainless steel.</p>	<p>HANDY AWL #HA3</p>  <p>Hardened point Hardwood handle Used for marking dots in pattern paper</p>	<p>BRASS TIPPED 60" FIBERGLASS TAPE MEASURE #242TM</p>  <p>Inches on one side - brass tip w/hole Metric on the other - alternate direction</p>
<p>SMALL SEAM RIPPER (3-1/2" overall length) #110R</p>  <p>Safety ball Hexagonal rib prevents rolling</p>	<p>LARGE SEAM RIPPER (5-1/2" overall length) #111R</p>  <p>Safety ball Sure grip handle Clear plastic ribbed cover</p>	<p>FLAT PATTERN SEAM RIPPER (5" overall length) #112R</p>  <p>Flat handle Safety ball Clear plastic cover Simulated wood handle</p>
<p><b>WHEEL CUTTER</b> AS VERSATILE AS IT IS SAFE</p> <p>It cuts patterns, fabrics, leather, vinyl, mylar.... even wallpaper. The wheel cutter's unique permanent blade guard retracts only when the cutter is in use, making it one of the safest tools in the cutting room.</p> <p>Both left and right handed. Cuts forward and backwards, straight and curves.</p> <p>Easily replaceable tungsten steel blades</p> 		<p><b>No. EW810</b> - Complete unit <b>No. EW801</b> - replacement blade 1-3/4" (4.5cm)</p> <p><b>No. EW800</b> - Complete unit <b>No. EW811</b> - replacement blade 1-1/16" (2.7cm)</p>

**Diamond Needle Corp.**

GPO BOX 1355 • 159 W 25 St. • New York, NY 10001  
Phone: (212) 929-2277 • (800) 221-5818  
FAX: (212) 242-8882 • (800) 833-3363



**WHITE  
DIAMOND**

# DIXON INDUSTRIAL CRAYONS & MARKERS

## DIXON TAILOR'S CRAYONS

Finest quality, compressed for long wearing, non-crumbling use. Withstands pressing. 2" square flat shaped double beveled.



- D901 RED
- D902 BLUE
- D903 WHITE
- D903-1/2 YELLOW

**PACKED 2 DOZEN PER BOX (Sold in multiples of 2 dozen)**

## DIXON CLOTH MARKER TEXTILE PENCILS

Semi-permanent formulation will not wash out or bleach out in most processes. Test carefully if bleach out is required. Dixon can assume no liability for fugitivity. Large diameter leads.

- D787B BLUE
- D787R RED
- D787G GREEN



**PACKED 1 DOZEN PER BOX (Sold in multiples of 1 dozen)**

## DIXON WASHOUT TEXTILE PENCILS

Special fugitive formulation designed to water-wash from most natural and synthetic fabrics. Dixon can assume no liability for fugitivity. Large diameter leads.

- D783B BLUE
- D783R RED
- D783G GREEN



**PACKED 1 DOZEN PER BOX (Sold in multiples of 1 dozen)**

## DIXON CHINA MARKING (PHANO)

This improved china marking pencil is one of the most versatile of all marking instruments. The opaque pigment marks all glazed and slick surfaces. Grit free, non-conductive leads. Round paper-wrapped with string for easy sharpening.

- D71 RED
- D73 YELLOW
- D77 BLACK
- D92 WHITE



**PACKED 1 DOZEN PER BOX (Sold in multiples of 1 dozen)**

## DIXON TAILORING PENCILS

- D349 RED      D352 WHITE
- D350 BLUE    D353 YELLOW

**THICK LEADED COLORED PENCILS**

**PACKED 1 DOZEN PER BOX  
(Sold in multiples of 1 dozen)**



**Diamond Needle Corp.**

GPO BOX 1355 • 159 W 25 St. • New York, NY 10001  
Phone: (212) 929-2277 • (800) 221-5818  
FAX: (212) 242-8882 • (800) 833-3363



PHOTOCOPY THIS ORDER FORM

# ORDER FORM

MAIL OR FAX TO US!

TO: **DIAMOND NEEDLE CORP.**  
159 West 25th Street / G.P.O. Box 1355  
New York, NY 10001



**WE NOW ACCEPT  
VISA, MASTERCARD  
and DISCOVER**



## CALL OR FAX US TOLL FREE!

**TELEPHONE: 1-800-221-5818**

**FAX: 1-800-833-3363**

INTERNATIONAL PHONE: 212-929-2277

INTERNATIONAL FAX: 212-242-8882

BILL TO: \_\_\_\_\_  
ADDRESS: \_\_\_\_\_  
CITY: \_\_\_\_\_  
STATE: \_\_\_\_\_ ZIP: \_\_\_\_\_  
PHONE: ( \_\_\_\_\_ ) \_\_\_\_\_  
ORDERED BY: \_\_\_\_\_

SHIP TO: \_\_\_\_\_  
ADDRESS: \_\_\_\_\_  
CITY: \_\_\_\_\_  
STATE: \_\_\_\_\_ ZIP: \_\_\_\_\_  
PHONE: ( \_\_\_\_\_ ) \_\_\_\_\_  
ATTENTION: \_\_\_\_\_

QUANTITY	ITEM NO.	DESCRIPTION	UNIT PRICE	EXTENSION

SUB-TOTAL	
NYS SALES TAX	
<b>TOTAL</b>	

**TERMS & CONDITIONS OF ORDERING**

**TERMS:** (1) Qualified accounts, approved by our credit department, are allowed NET-30 DAYS. (ask for credit application).

**SALES TAX:** We are only responsible for NYS sales tax.

**F.O.B., NEW YORK, NY:** All items are sold F.O.B. NY, NY.

**METHOD OF SHIPMENT:** Unless specified otherwise, we reserve the right to determine the best method of shipment.

**MINIMUM ORDERS:** In order to help keep our prices low, we have a requirement of a minimum order of \$25.00 excluding freight and sales tax. A service charge of \$5.00 will be added to orders under \$25.00. Avoid any service charge by increasing your order with some item(s) that you'll always need... thank you.

**CREDIT CARD INFORMATION**

TYPE:  VISA  MASTERCARD  DISCOVER

NAME ON CARD: \_\_\_\_\_

CARD NO.: \_\_\_\_\_

EXPIRATION DATE: \_\_\_\_\_

SIGNATURE: \_\_\_\_\_

**PLEASE NOTE: TO USE ORDER FORM WE SUGGEST THAT YOU MAKE A COPY OF THIS FORM. IF YOU NEED MORE ITEMS THAN THERE IS ROOM FOR... MAKE AN EXTRA COPY FOR THE ADDITIONAL ITEMS. THANK YOU.**

# ORGAN NEEDLES



We stock thousands of additional items that are not shown in this catalog. If you do not see what you need - call and ask!

OR

You can E-mail us at: [Diamond-Needle@worldnet.att.net](mailto:Diamond-Needle@worldnet.att.net)

## A SEWING MACHINE IS ONLY AS GOOD AS THE NEEDLE IN IT!

The Organ Needle Company works closely with all of Japan's sewing machine builders to design and manufacture needles for optimal performance. A machine builder cannot afford to buy an inferior needle at any price!

Next time you order replacement needles for your best machines, order the needles your machine builder uses. When you buy **ORGAN** needles for their outstanding performance you get their *low price* as a bonus.

Would any machine builder jeopardize his reputation by supplying an inferior needle with his machine? How much could he save, .10 or .20 per needle, \$1.00 or \$2.00 per machine? The price of a needle is not a factor to him -- *PERFORMANCE is the factor!* Price is an added benefit, a bonus you always get with every box of **ORGAN** needles.

**ORGAN** needles are supplied with every new machine from:  
**BROTHER, JUKI, MITSUBISHI, YAMATO, KANSAI, PEGASUS, CONSEW, TAJIMA, BARUDAN, NAKAJIMA, KINGLINE, NEWLONG, TOYOTA, RENOWN,**  
and many more...

After you've used-up the *free* needles packed with your new machine, which performed flawlessly, WHY change to a more expensive needle? What can you gain? How could any needle at any price be better than those made to the machine builder's specifications? How could a copy, even a more expensive copy, be better than O.E.M. specs?

**Diamond Needle Corp.** GPO BOX 1355 • 159 W 25 St. • New York, NY 10001  
Phone: (212) 929-2277 • (800) 221-5818  
FAX: (212) 242-8882 • (800) 833-3363



**DIAMOND NEEDLE CORP.**

G.P.O. Box 1355  
 159 West 25th Street  
 New York, NY 10001  
 Phone: (212) 929-2277 • (800) 221-5818  
 Fax: (212) 242-8882 • (800) 833-3363

**We're your source...  
 DELIVERY QUALITY ECONOMY**

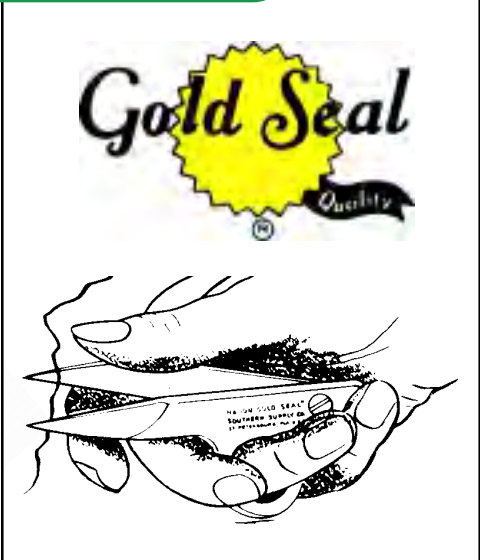

**Performance Beyond The Ordinary!**

**Diamond  
 Needle  
 Corp.**



**WHITE  
 DIAMOND**

G.P.O. 1355  
 159-163 WEST 25<sup>TH</sup> STREET  
 NEW YORK, NY 10001  
 E-mail: [Diamond-Needle@worldnet.att.net](mailto:Diamond-Needle@worldnet.att.net)



**212-929-2277  
 CALL TOLL-FREE  
 1-800-221-5818**



**1-800-833-3363  
 (DOMESTIC)  
 212-242-8882  
 (INTERNATIONAL)**