

# PORTABLE BAG CLOSER

HIGH-SPEED NEW TYPE WITH  
SAFETY PLASTIC HANDLE &  
POWERFUL OIL LUBRICATOR

AK-7A  
AK-7B  
AK-7C  
AK-7H  
AK-7BC  
AK-7A-2

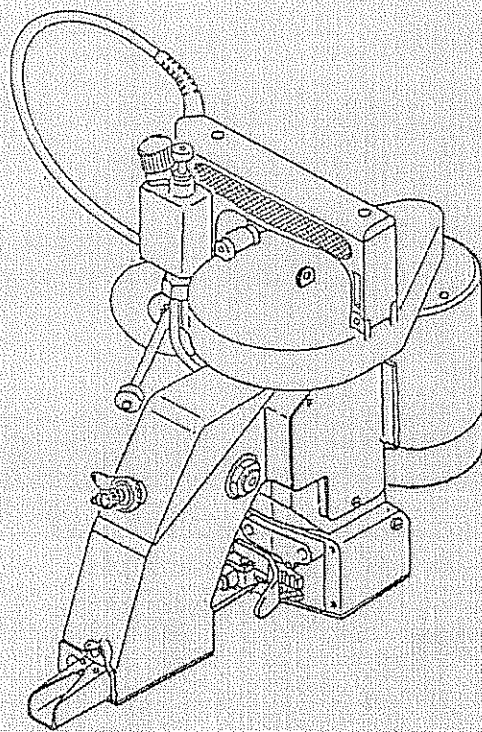

IDEAL FOR CLOSING BAGS FOR AGRICULTURAL  
PRODUCTS, ANIMAL FEEDS, FERTILIZER,  
CHEMICALS AND ETC.

# CONTENTS

---

1. SPECIFICATIONS .....	2
2. PREPARATION FOR START .....	3
1. Oiling .....	3
2. Needle Setting .....	3
3. Threading .....	3
3. START .....	4
4. ADJUSTMENTS .....	5
1. Thread Tension .....	5
2. Position of Needle and Loper .....	5
3. Position of Feed Dog .....	5
4. Pressure of Presser Foot .....	5
5. REPLACING PARTS .....	6
6. MAINTENANCE & LUBRICATION .....	7
7. LUBRICATOR .....	7
1. Operation .....	7
2. Maintenance .....	7
3. Troubleshooting .....	8
8. ORDERING PARTS .....	9
NUMERICAL INDEX OF PARTS .....	26
DIAGRAM OF SCREW, NUT & WASHER .....	28

---

## 2. PREPARATION FOR START

### 1. Oiling (Fig.1)

Oiling is imperative to keep the machine in good operating condition. Fill oil in the reservoir (capacity 45 cc). To feed oil, push the button of the lubricator. One push feeds 0.08 cc of oil, which would normally service for several hours of operation. Do not run the machine out of oil, otherwise it will break down.

### 2. Needle Setting (Fig.2, 3, 4)

Turn the pulley until Needle Bar reaches its highest position. Loosen Needle Bar Clamping Nut, and set Needle in the Bar as deep as it will go.

Be sure to set a Needle with its concave part facing correctly toward the Loper. Fix Clamping Nut tightly, otherwise Needle may come loose during operation and break.

### 3. Threading (Fig.5)

The machine is delivered being threaded to show you proper threading of the machine, which is shown in Fig.5, for identification. Follow the guide numbers 1 to 7 of Fig.5.

- |                 |                 |
|-----------------|-----------------|
| ① Thread Eyelet | ⑤ Needle Bar    |
| ② Tension Disc  | ⑥ Thread Eyelet |
| ③ Thread Eyelet | ⑦ Needle        |

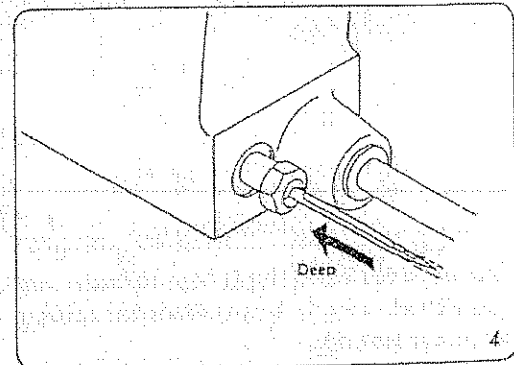
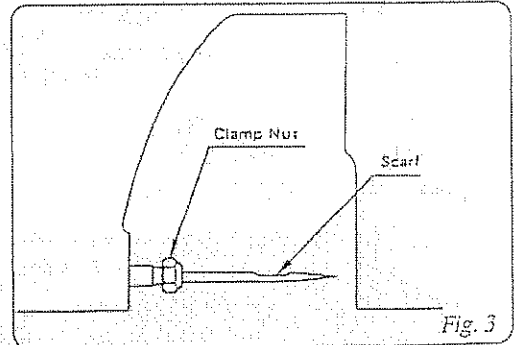
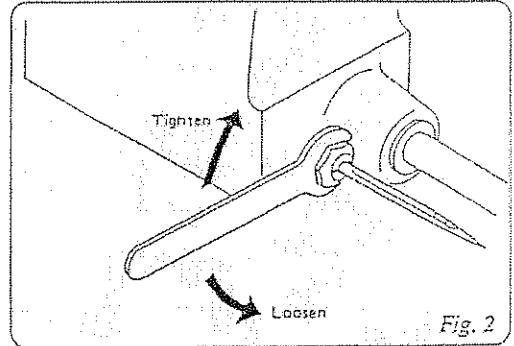
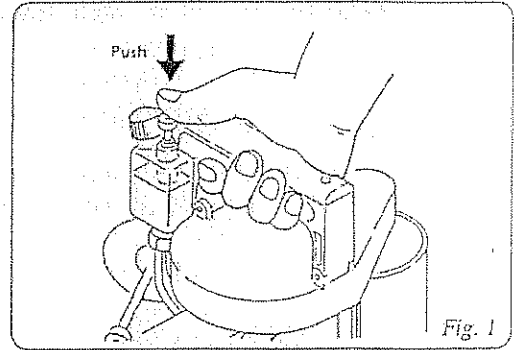
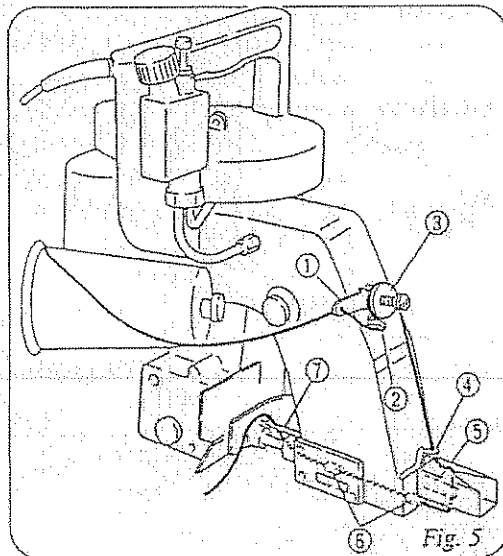

Belt.



### 3. START

Before starting, make sure that the supply voltage accords with the specification of the motor.

Hold the machine in your right hand and place your index finger on the switch button on the handle.(Fig.6)

Hold the bag in your left lightly and insert the bag mouth between Feed Dog and Presser Foot.(Fig.7)

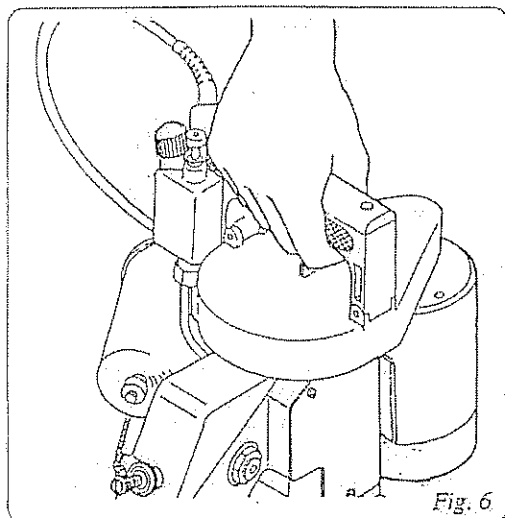

Run the machine while keeping the bag straight.

Never pull or pull back the bag.

After closing, the thread is cut by the built-in nibbler type cutter.

When cutting the thread, leave at least 3 cm long extended tail to prevent the unwilling loosening of the seam.(Fig.9)

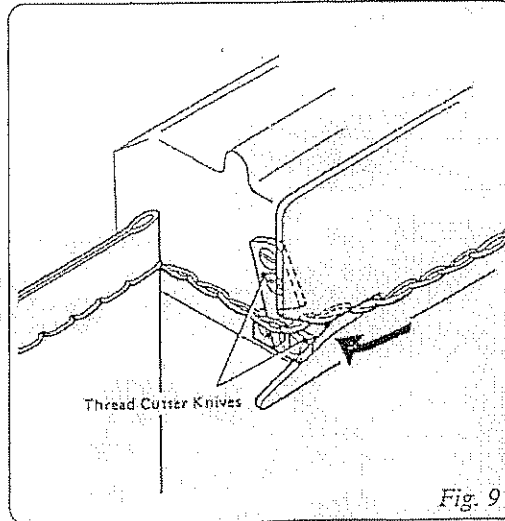
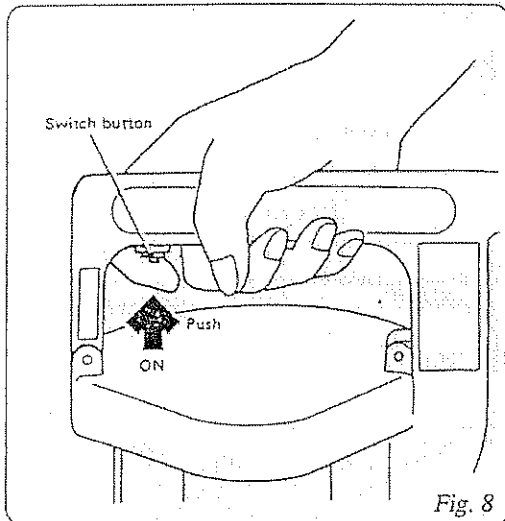
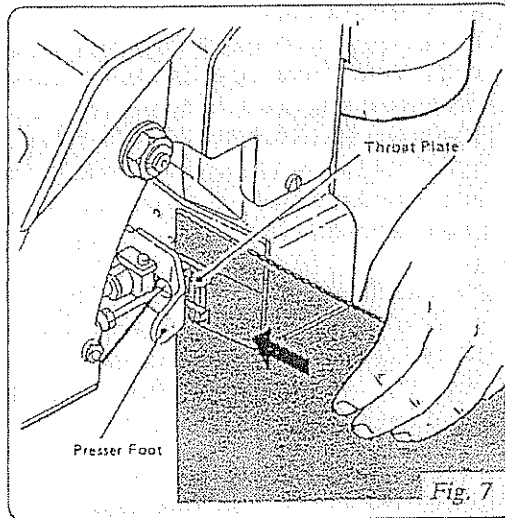

Run the machine with empty bags and make sure you are well versed in its operation before entering into actual operation.

### 4. ADJUST

1. Thread Tension  
Thread tension is adjusted by the Tension Nut.

Turn the Nut clockwise for loose

2. Position of Needle  
The Needle must pass through the clearance of 0.1 mm between the Needle and the Needle Plate. The clearance of the Needle and the Needle Plate must be adjusted by the Needle Position Adjuster.

3. Position of Feed Dog  
The Feed Dog should be in the highest position. The position of the Feed Dog is determined by the Feed Dog Support Screws.

4. Pressure of Presser Foot  
When to adjust the Presser Foot Pressure. Move the Presser Foot Pressure Adjuster up and down to adjust the pressure of the Presser Foot.

E-mail: info@sewingmachinecorp.com

## 4. ADJUSTMENTS

### 1. Thread Tension

Thread tension is adjustable by turning the Thread Tension Nut.

Turn the Nut clockwise for tighter tension and counter-clockwise for looser.

### 2. Position of Needle and Loper (Fig.10)

Looper must pass the concave part of Needle with clearance of 0.1 mm as shown in Fig.10. Adjustment of the clearance can be done after loosening the screw of Loper Rocker.

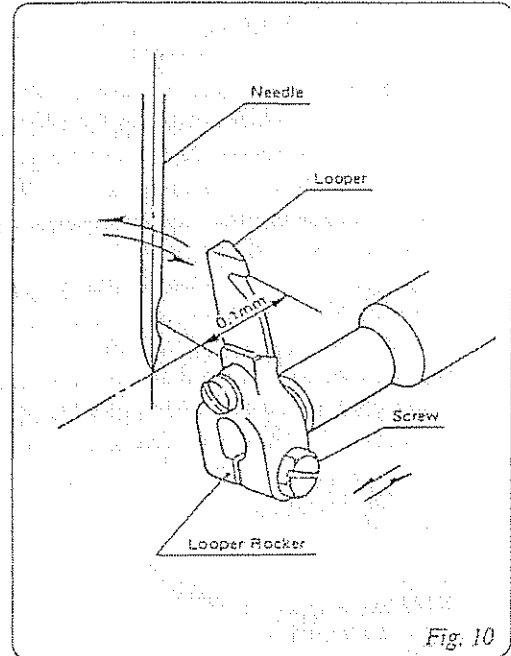

Fig. 10

### 3. Position of Feed Dog

Feed Dog should be 2.5 mm above throat plate at its highest position as shown in Fig.11. The height of Feed Dog is determined by the height of Feed Dog Support Screws (4 pcs. in all).

### 4. Pressure of Presser Foot

When to adjust the pressure of Presser Foot, take out Needle Bar Guard and loosen Screw of Presser Bar Connection. Move up Presser Bar to increase the pressure and down to decrease. After the adjustment, tighten the Screw firmly.

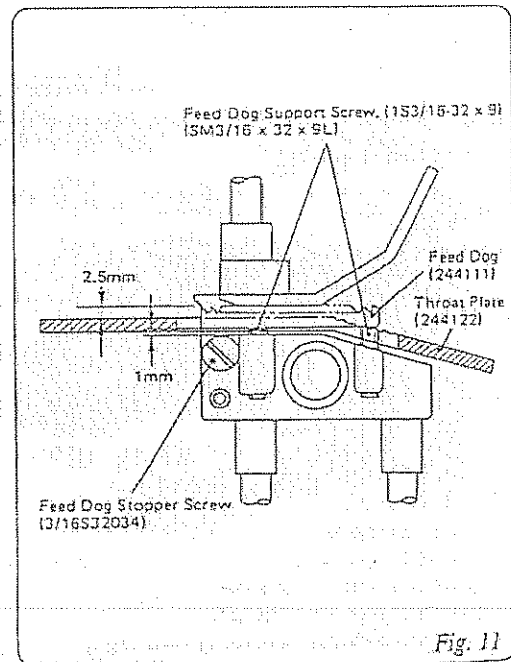

Fig. 11

rag straight.

built-in nibbler

least 3 cm long  
ng loosening of

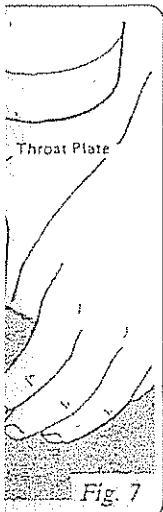

Fig. 7

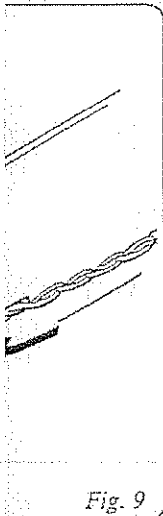

Fig. 9

## 5. REPLACING PARTS

For replacement or adjustment of Ball Rod, refer to Fig.12.

Take out Screw ① and disconnect Rod End ② from Needle Bar Lever ③. After loosening the Nut ④, adjust the clearance between Connecting Rod ⑤ and Rod End ②, so that Needle Bar moves in the center of the clearance between the upper and lower Presser Bar Bushings. (Needle Bar stroke is 37 mm).

To fix Eccentric Cam ⑦ on Main Shaft ⑧, tighten the Screws ⑨ and ⑩ on Main Shaft ⑧ (Eccentric Cam ⑦ should contact Spacer ⑩ slightly).

The position of Needle is adjusted so that the distance between the point of Needle (at its highest position) and Throat Plate is 13 mm, after loosening screw on Needle Bar Connection Assembly ⑥ in Fig.12.

① Screw 11/64S40089

② Rod End 6APOS8

③ Needle Bar Lever 242051A

④ Nut IN8

⑤ Connecting Rod Assembly 242011A

⑥ Needle Bar Connection Assembly 242101A

⑦ Eccentric Cam (part of Connecting Rod Assembly) 242011

⑧ Main Shaft 241101

⑨ ⑩ Screw 11/64S40031

⑩ Spacer 241151

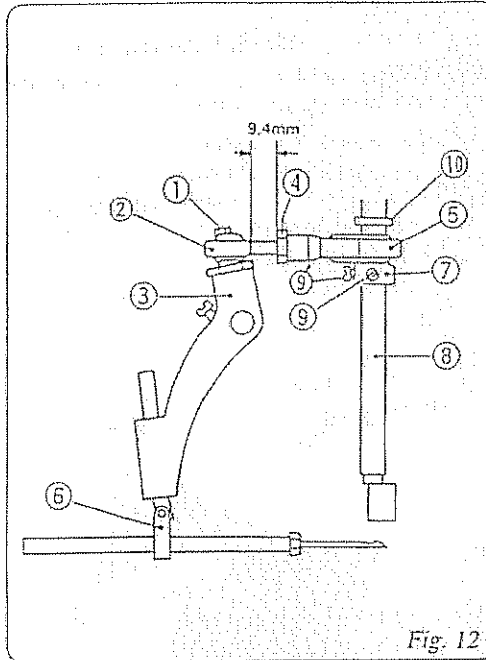

Fig. 12

Adjust Looper Drive Cam ③ When necessary as follows: (Refer to Fig.13.).

a) Apply the Screws ② and ② on the taper of Main Shaft ①.

b) Adjust Arm (B) ④, so that Looper Drive Cam ③ and Arm (A) ⑤ move smoothly. After adjusting, fix the Screw ⑥ tightly.

c) The clearance between Looper Drive Cam ③ and Arm ⑤ is effected by Spring ⑦. Loosen Screw ⑨ and turn Spring Supporter ⑧ to adjust the pressure of Spring ⑦. After adjusting, tighten the Screw ⑨ to fasten Spring Supporter ⑧.

① Main Shaft 241102

② ② Screw 15/64S28524

③ Looper Drive Cam 243012

④ Looper Rocker Shaft Arm (B) 243081

⑤ Looper Rocker Shaft Arm (A) 243071

⑥ Screw for Looper Rocker Shaft Arm (B) 11/64S40009

⑦ Spring 243131

⑧ Spring Supporter 243121

⑨ Screw for Spring Supporter Block 11/64S40003

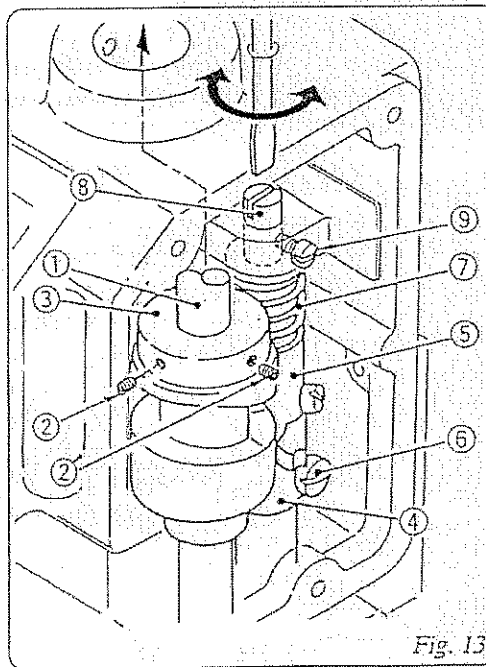

Fig. 13

## 6. MA

Clean the main  
Wipe dust and c  
teeth Looper an  
easily gathered.  
Care should be  
rust, especially  
time.

Important!

When adjusting t  
This is important!

## 7. LUT

### 1. Operation

The lubricator  
The reservoir h  
volume is 28 cc  
To operate the l

1. First unscrew
2. Push the bu  
12mm).
3. When relea  
return to its c
4. Lastly, tight  
operation.

Repeated wor  
the cap mai  
reservoir, an  
easily introd



## 6. MAINTENANCE & LUBRICATION

Clean the machine at the end of the day's work. Wipe dust and other foreign matter off the Feed Dog teeth, Loper and Throat Plate eyelets where they are easily gathered.

Care should be taken to keep the machine free from rust, especially when to leave it unused for some time.

Recommended lubricants are Shell X-100, Motor Oil 10W/30, Shell Vitria Oil 31 or the equivalent. For operation and maintenance of the lubricator, refer to Section 7.

### Important!

When adjusting the machine or replacing parts, always disconnect the Electric Cord from the power source. This is important in view of safety to the operator and adjuster.

## 7. LUBRICATOR

### 1. Operation

The lubricator comprises a pump and a reservoir. The reservoir holds max 45 cc of oil. (Effective oil volume is 28 cc.)

To operate the lubricator:

1. First unscrew the reservoir cap by half a turn.\*
2. Push the button to its lowest position (stroke: 12mm).
3. When released, the button will automatically return to its original position.
4. Lastly, tighten the cap to prevent oil leak during operation.

\* Repeated working on the button without first loosening the cap may produce negative pressure in the reservoir, and the dust in the atmosphere may be easily introduced in it when the cap is loosened.

### 2. Maintenance

1. Keep off dust or foreign matter when to fill oil (They may cause jamming of the piston and the check valve).
2. Rate of discharge is fixed and not adjustable (0.08cc per push).
3. At high temperatures, grease may run along points (A). This is normal, grease being used when the lubricator was assembled in our plant.
4. Reservoir is made of high density polyethylene. Keep off fire and refrain from using organic, benzene, or xylene chemicals for cleaning. Check periodically for correct working of the pump. (Repeat oil feed and look at the oil through the discharge pipe.)

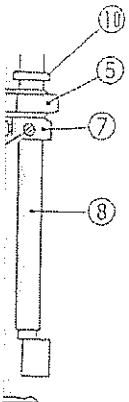

Fig. 12

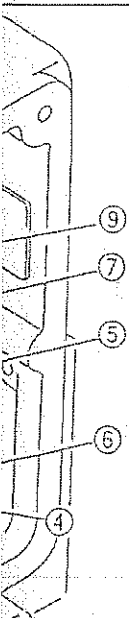
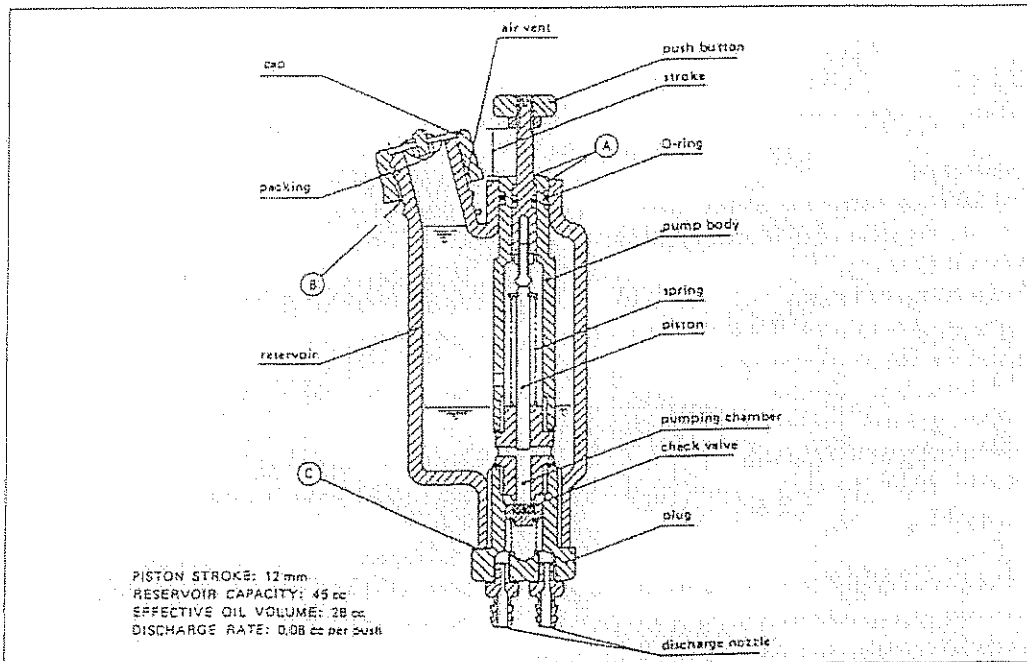

Fig. 13

### 3. Troubleshooting

Trouble	Cause	Remedy
Oil not fed.	Low oil level.	Fill oil.
Full stroke movement not obtainable.	Dust attached on the interior wall of the pumping chamber.	Replace lubricator.
Button will not return.	Dust accumulated, or break of spring.	Replace lubricator.
Oil leak from (A)	Wornout or displaced seal of O-Ring.	Replace lubricator.
Oil leak from (B)	Wornout or displaced seal of packing.	Replace lubricator.
Oil leak from (C)	Loose plug.	Tighten plug or Replace lubricator.

### PUSH-BUTTON LUBRICATOR



### 8. ORD

The parts list should be checked. Send your order.

1. Description of
2. Screws and nuts
3. Stamp number
4. The parts with assembly.
5. A set of assembly.
6. The last figure
7. Parts No. description
8. The parts list

- (1) TI
- (2) B
- (3) N
- (4) L
- (5) F
- (6) M
- (7) S
- (8) C

N  
D



## 8. ORDERING PARTS

The parts list showing all the parts used in the machine is included in this book. Check the list, and specify parts numbers and quantities required clearly. Send your order to the nearest agent, distributor or one of our branch offices.

1. Description of each part and its stamp number is described in this parts list. Screws and nuts for parts are shown adjacent to the relevant parts. When ordering parts, describe clearly stamp number with its name of part.
  2. The parts which have no Ref. Number can not be delivered independently; always order it as an assembly.
  3. A set of assembled parts is represented by the stamp number of its main parts.
  4. The last figure on the parts stamp number advances on each improvement of the parts.
  5. Parts No. described in [ ] of Remarks means old parts No.
- \* The parts list is subject to change without prior notice.

## CONTENTS

(1)	THREAD TENSION AND COVERS PARTS .....	10
(2)	BUSHING, OILINGS AND HANDLE PARTS .....	12
(3)	NEEDLE BAR, PRESSER BAR AND DRIVING PARTS .....	14
(4)	LOOPER DRIVING PARTS.....	16
(5)	FEED DRIVING AND THREAD CUTTER PARTS.....	18
(6)	MOTOR PARTS (For Totally Enclosed Type Motor) .....	20
(7)	SPECIAL PARTS (For Ak-7A-2) .....	22
(8)	CREPE TAPE BINDING AND CUTTER PARTS (Special Order Parts) .....	24
	NUMERICAL INDEX OF PARTS .....	26
	DIAGRAM OF SCREW, NUT & WASHER.....	28

(1) THREAD TENSION AND COVER PARTS

(1) THREAD

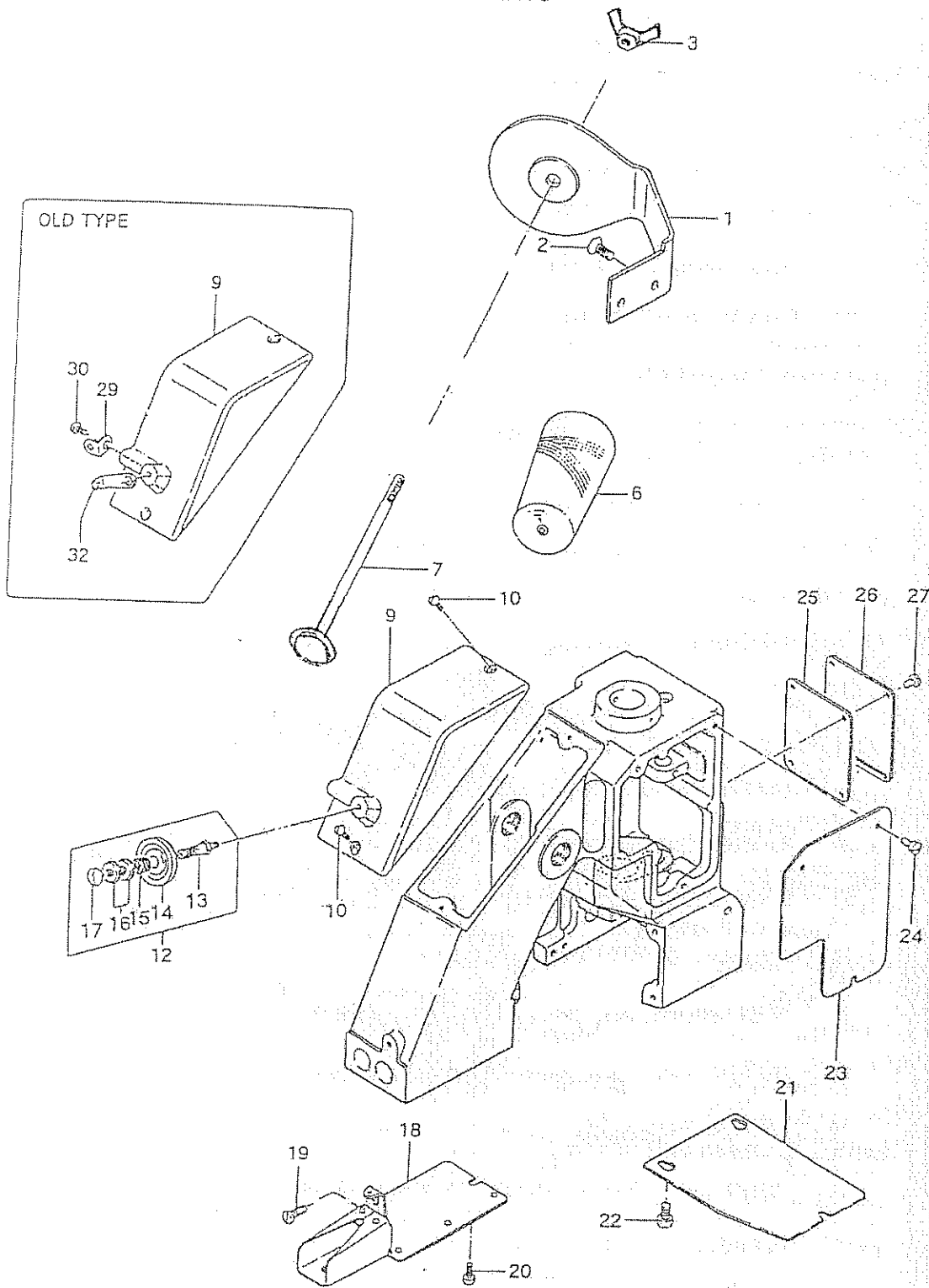

Qty No.	Part No
1	245042
2	15/64S280
3	1N6
4	
5	K01001
6	245052
7	
8	245014
9	9/64S4000
10	
11	245081A
12	245081
13	065261
14	245101
15	245091
16	9/64S400
17	245033
18	11/64S400
19	9/64S4006
20	245222
21	9/64S4006
22	245022
23	9/64S4000
24	245481
25	245302
26	9/64S4000
27	245261
28	11/64S400
29	
30	245071
31	
32	

From the library of Diagram and Assembly

(1) THREAD TENSION AND COVER PARTS

Key No.	Part No.	Description	Qty	Remarks
1	245042	Thread Stand	1	
2	15/64S28028	Screw, for 245042	2	
3	1N6	Nut	1	
6	K01001	Thread	1	
7	245052	Thread Conc Clamping Rod	1	
9	245014	Top Cover	1	
10	9/64S40005	Screw, for 245014	2	
12	245081A	Thread Tension Assembly	1	(13~17)
13	245081	Tension Post	1	
14	065261	Tension Disc	2	
15	245101	Tension Spring	1	
16	245091	Tension Nut	2	
17	9/64S40011	Screw, for 245081A	1	
18	245033	Needle Bar Guard	1	
19	11/64S40005	Screw, for 245033	1	
20	9/64S40065	Screw, for 245033	2	
21	245222	Looper Cover	1	
22	9/64S40065	Screw, for 245222	3	
23	245022	Side Plate	1	
24	9/64S40005	Screw, for 245022	3	
25	245481	Gasket	1	
26	245302	Inside Cover	1	
27	9/64S40005	Screw, for 245302	4	
29	245261	Thread Eyelet	1	} Old Type
30	11/64S40006	Screw, for 245261	1	
32	245071	Thread Tension Eyelet	1	

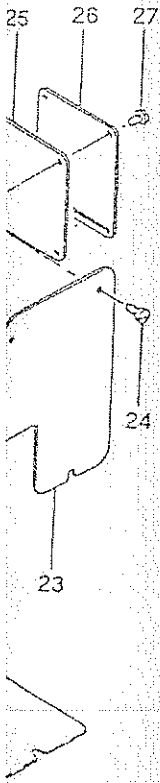



(2) BUSHINGS, OILINGS AND HANDLE PARTS

(2) BUSHI

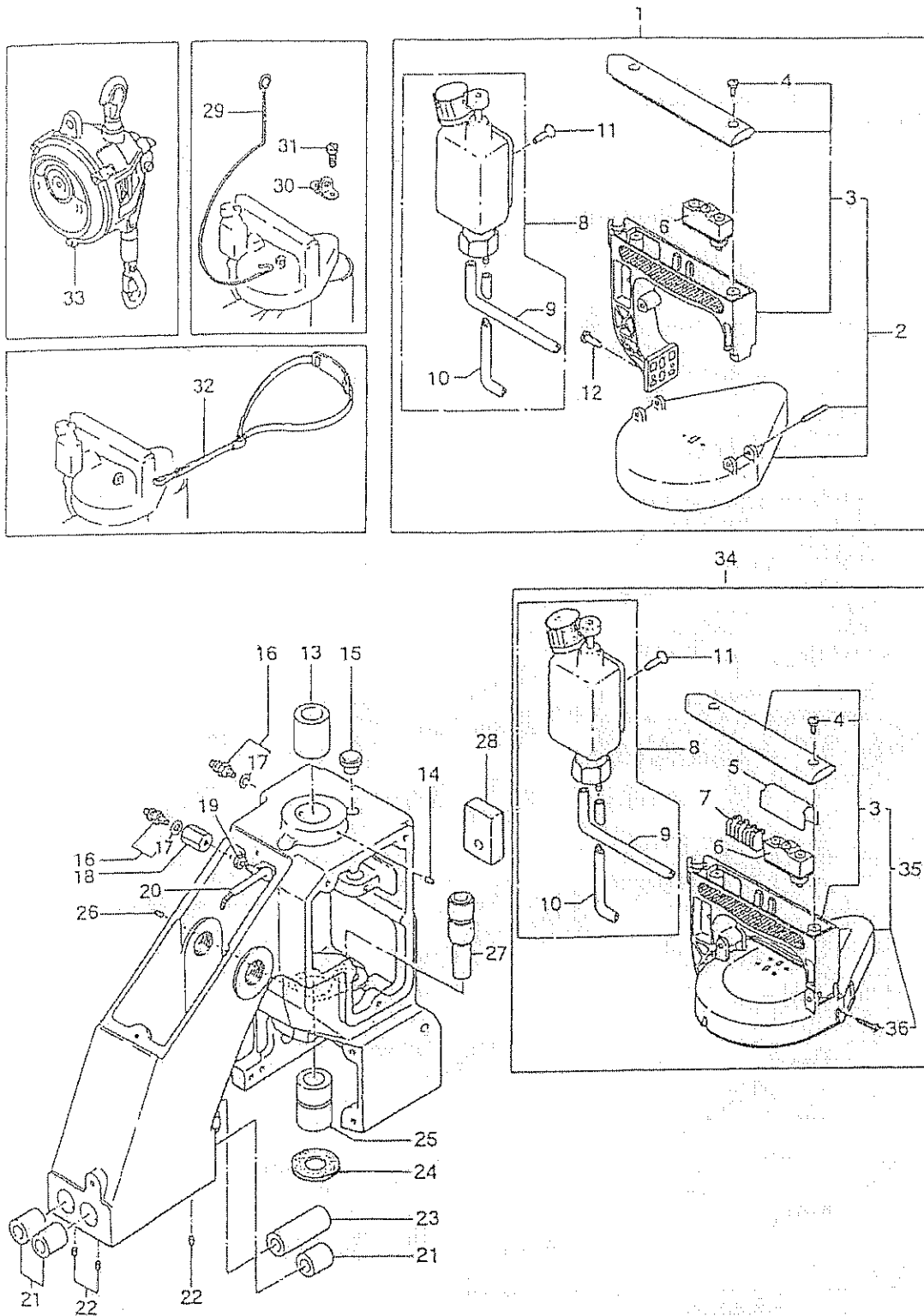

Key No.	Part
1	241024
2	24102
3	24101
4	9/64S
6	C0200 C0200
8	D0300
9	8FU
10	8FU
11	6S5x1
12	15/64S
13	241122
14	9/64S4
15	063401
16	D07021
17	E030
18	245471
19	1N4
20	245461
21	242212
22	9/64S4
23	242222
24	245541
25	241111
26	9/64S4
27	243021
28	245162
29	245271
30	241151
31	1/8S40
32	245171
33	EW-6.
34	241024
35	24102
36	9S2.

From the...

(2) BUSHINGS, OILINGS AND HANDLE PARTS

Key No.	Part No.	Description	Qty	Remarks
1	241024AS	Handle Assembly	1	2,5~11
2	241024A	Handle Assembly	1	(3,4)
3	241024	Handle	1	(4)
4	9/64S40011	Screw, for 241024A	2	
6	C02001	Micro Switch (Z-15GK655-B)	1	
	C02006	Micro Switch (X-10GD-B)	1	for DC motor
8	D03003	Oiler	1	(9,10)
9	8FU2-6x90F	Oil Tube, with oil felt	1	
10	8FU2-6x60F	Oil Tube, with oil felt	1	
11	6S5x15	Screw, for D03003	1	
12	15/64S28021	Screw, for 241024A	2	
13	241122	Main Shaft Bushing, rear	1	
14	9/64S40502	Screw, for 241122	1	
15	065401	Rubber Bushing	1	
16	D07021	Joint (BN-5-6)	2	(17)
17	E03014	Washer	2	
18	245471	Joint	1	
19	1N4	Nut	1	
20	245461	Oil Pipe	1	
21	242212	Bushing for Presser Bar & Needle Bar, upper	3	
22	9/64S40502	Screw, for 242212	3	
23	242222	Presser Bar Bushing, lower	1	
24	245541	Oil Felt	1	
25	241111	Main Shaft Bushing, lower	1	
26	9/64S40502	Screw, for 241111	1	
27	243021	Looper Rocker Shaft Bushing	1	
28	245162	Oil Felt	1	
29	245271	Hanger	(1)	Special Order
30	241151	Hook	(1)	
31	1/8S40006	Screw, for 241151	(2)	
32	245171	Shoulder Belt	(1)	
33	EW-6.5	Spring Balancer	(1)	
34	241024BS	Handle Assembly (Safety type with pulley cover)	(1)	5~11,35
35	241024B	Handle Assembly (Safety type with pulley cover)	(1)	(3,4,36)
36	9S2.6x10	Screw, for 241024B	(1)	

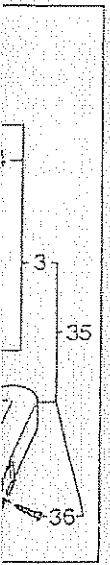
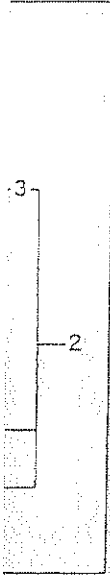

From the library of: Diamond Needle Corp

(3) NEEDLE BAR, PRESSER BAR AND DRIVING PARTS

(3) NEEDLE B

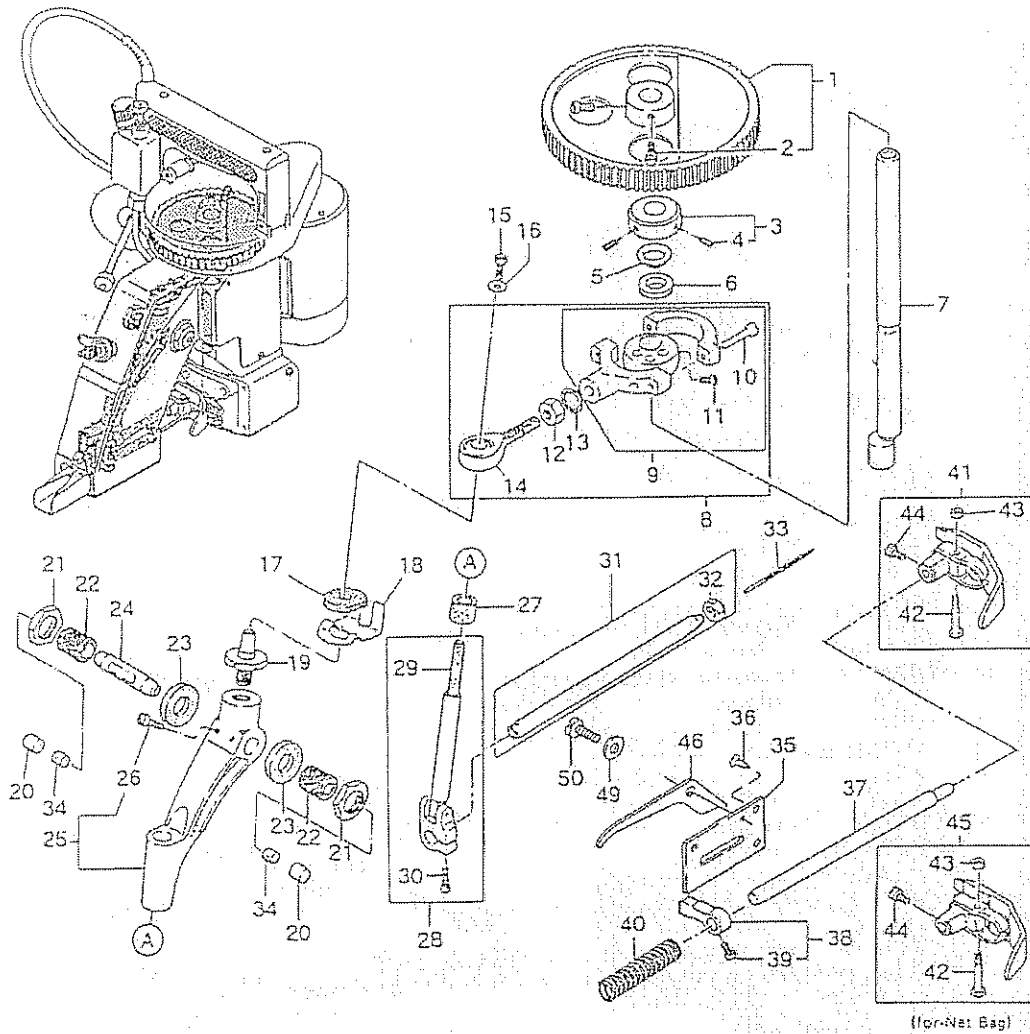

Key No.	Part No.
13	5W8
14	6A04001
15	11/64S40084
16	11/64W15103
17	245211
18	242041
19	242031
20	245491
21	5/8N18101
22	242081
23	245231
24	242071
25	242051A
26	11/64S4000
27	245371
28	242101A
29	205171
30	11/64S4000
31	242121A
32	242131
33	B01002
34	065561
35	242172
36	11/64S40002
37	242201
38	242181
39	11/64S4000
40	242191
41	242231A
42	9/64S40055
43	9/64N43101
44	11/64S4000
45	242233A
46	242161
49	11/64W15103
50	11/64S40069

Key No.	Part No.	Description	Qty	Remarks
1	241092	Synchro Pulley	1	(2)
2	3/16S28001	Screw, for 241092	2	(4)
3	241131	Retaining Collar	1	
4	11/64S40502	Screw, for 241131	2	
5	241161	Spacer	1	
6	205131	Oil Felt	1	
7	241102	Main Shaft	1	
8	242011A	Connecting Rod Assembly	1	(9~14)
9	242011	Connecting Rod Sub-Assembly	1	(10,11)
10	3/16S28029	Screw, for connecting rod cap	2	
11	11/64S40001	Screw, for eccentric cam	2	
12	1N8	Nut, for 242011A	1	

From the library of Diamond Needle Corp



## NEEDLE BAR, PRESSER BAR AND DRIVING PARTS

No.	Part No.	Description	Qty	Remarks
3	5W8	Washer, for 242011A	1	
4	6A04001	Rod End (POS-8)	1	
5	11/64S40084	Screw, for 242031	1	
6	11/64W15103	Washer, for 242031	1	
7	245211	Oil Felt	1	
8	242041	Spring	1	
9	242031	Rod End Stud	1	
10	245491	Cap	2	
11	5/RN18101	Nut, for 242081	2	
12	242081	Adjusting Stud	2	
13	245231	Oil Felt	2	
14	242071	Needle Bar Lever Stud	1	
15	242051A	Needle Bar Lever Assembly	1	(26)
16	11/64S40004	Screw, for 242051A	2	
17	245371	Oil Felt	1	
18	242101A	Needle Bar Connection Assembly	1	(29,30)
19	205171	Oil Felt	1	
20	11/64S40003	Screw, for 242101A	1	
21	242121A	Needle Bar with Nut	1	(32)
22	242131	Needle Clamp Nut	1	
23	B01002	Needle(DN×1 #25)	1	
24	065561	Oil Felt	2	
25	242172	Presser Foot Lifter Base	1	
26	11/64S40002	Screw, for 242172	3	
27	242201	Presser Bar	1	
28	242181	Presser Bar Connection	1	(39)
29	11/64S40003	Screw, for 242181	1	
30	242191	Presser Spring	1	
31	242231A	Presser Foot Assembly	1	(42~44)
32	9/64S40055	Screw	1	
33	9/64N40101	Nut	1	
34	11/64S40003	Screw, for 242231A, 242233A	1	
35	242233A	Presser Foot Assembly (for Net Bag)	(1)	(42~44)
36	242161	Presser Foot Lifter	(1)	Special Order
37	11/64W15103	Washer	(1)	
38	11/64S40009-1	Screw, for 242161	(1)	

—7—

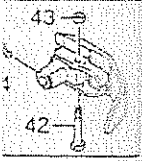
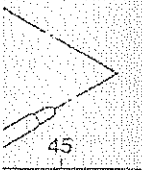
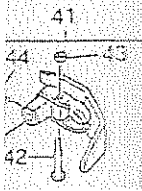

(for Net Bag)

Remarks

2)

4)

9~14)

10,11)

(4) LOOPER DRIVING PARTS

(4) LOOPE

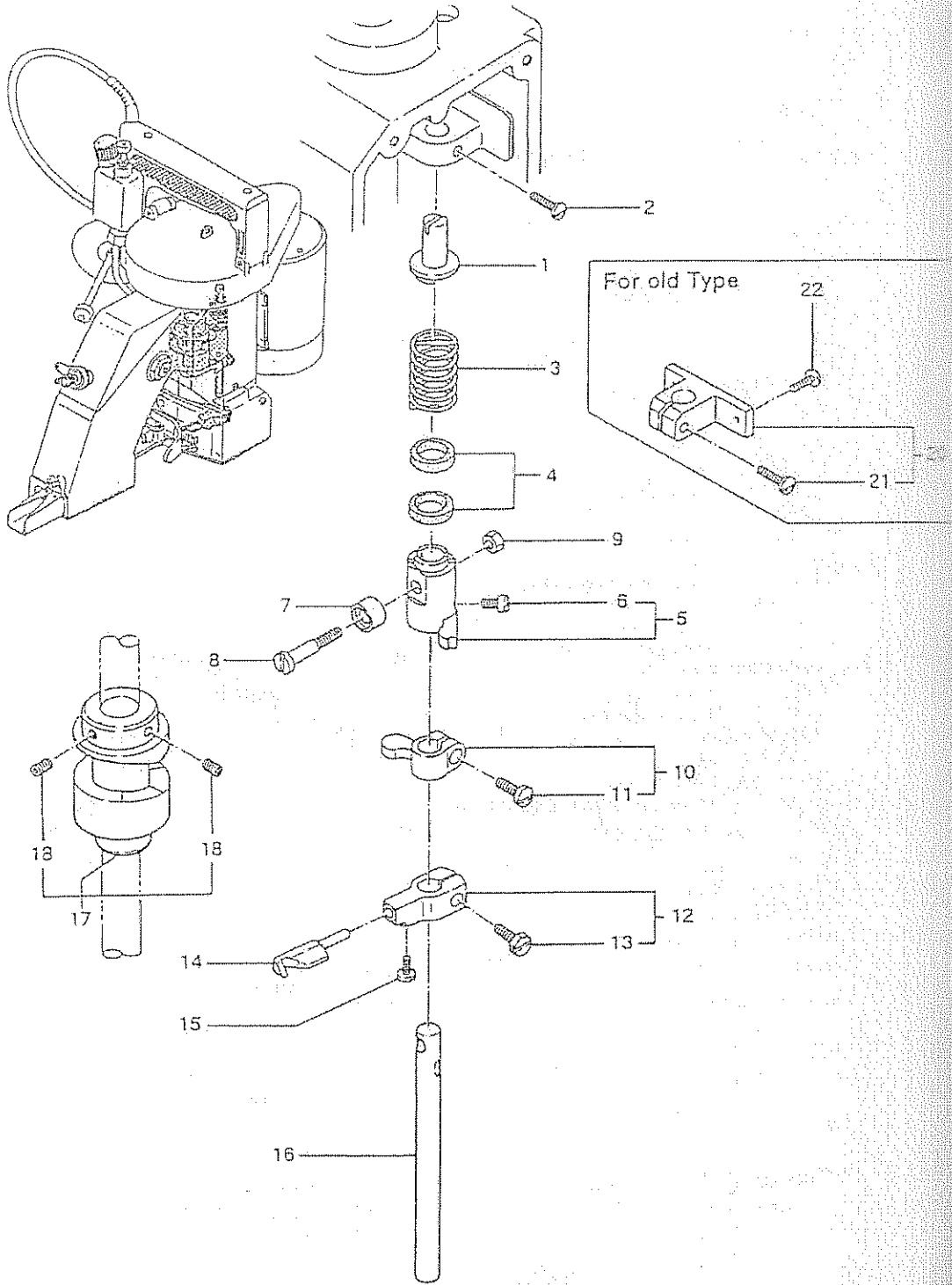

Key No.	Part No.
1	243121
2	11/64S40
3	243131
4	205131
5	243071
6	11/64S
7	243041
8	243061
9	11/64N4
10	243081
11	11/64S
12	243092
13	11/64S
14	243102
15	9/64S4
16	243032
17	243012
18	15/64S
19	243111
20	9/64S4
21	9/64S4
22	9/64S40

From the library of: Diamond Needle Corp.

4) LOOPER DRIVING PARTS

Key No.	Part No.	Description	Qty	Remarks
1	243121	Spring Supporter	1	
2	11/64S40003	Screw, for 243121	1	
3	243131	Spring	1	
4	205131	Oil Felt	2	
5	243071	Looper Rocker Shaft Arm (A)	1	(6)
6	11/64S40002	Screw, for 243071	1	
7	243041	Roller	1	
8	243061	Roller Stud Screw	1	
9	11/64N40201	Nut, for 243061	1	
10	243091	Looper Rocker Shaft Arm (B)	1	(11)
11	11/64S40009	Screw, for 243091	1	
12	243092	Looper Rocker	1	(13)
13	11/64S40089	Screw, for 243092	1	
14	243102	Looper	1	
15	9/64S40001	Screw, for 243102	1	
16	243032	Looper Rocker Shaft	1	
17	243012	Looper Drive Cam	1	(18)
18	15/64S28524	Screw, for 243012	2	
20	243111	Spring Supporter Block	1	(21)
21	9/64S40035	Screw, for 243111	1	for Old Type
22	9/64S40005	Screw, for 243111	2	

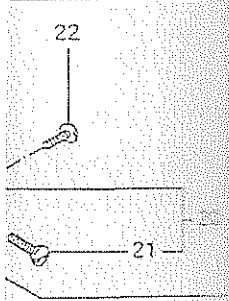

From the library of: Diamond Needle Corp



(5) FEED DRIVING AND THREAD CUTTER PARTS

(5) FEED DF

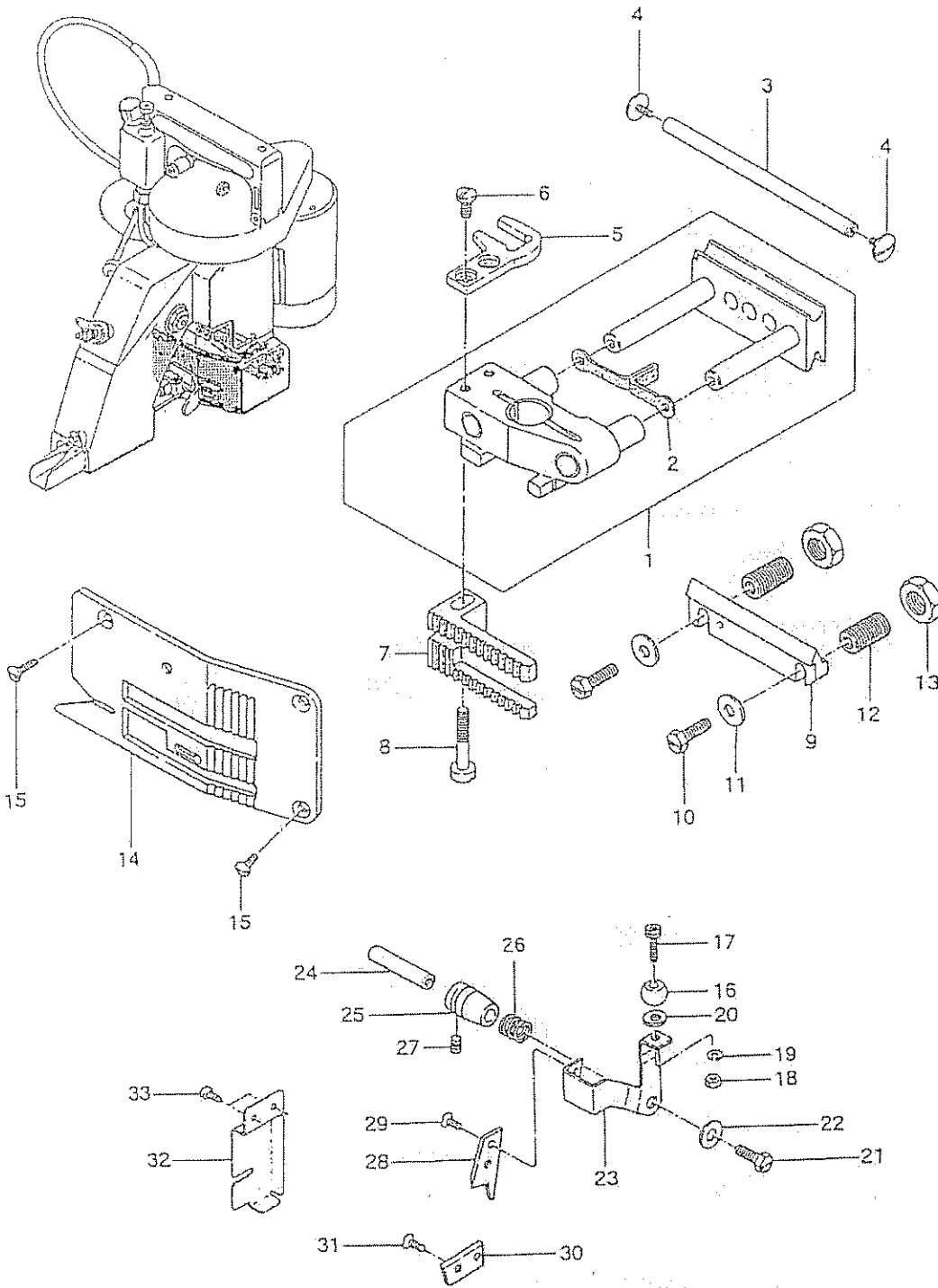

Key No.	Part No.
1	244011A
2	245391
3	244102
4	9/64S40011
5	246011
6	3/16S32031
7	244111
8	3/16S32034
9	244081
10	3/16S32025
11	11/64W151
12	244091
13	3/8N24201
14	244122
15	9/64S40043
16	246081
17	4B3x12
18	1N3
19	3W3
20	1W3
21	11/64S40041
22	11/64W151C
23	246021
24	246032
25	246042
26	246051
27	9/64S40502
28	246061
29	1/8S40003
30	246071
31	1/8S40003
32	245561
33	1/8S40006

From the library of: Team and Needle Co.

(5) FEED DRIVING AND THREAD CUTTER PARTS

Key No.	Part No.	Description	Q'ty	Remarks
1	244011A	Feed Dog Carrier Block Assembly	1	(2)
2	245391	Oil. Felt	1	
3	244102	Slide Block Guide Stud	1	
4	9/64S40011	Screw, for 244102	2	
5	246011	Knife Bracket Extension	1	
6	3/16S32031	Screw, for 246011	2	
7	244111	Feed Dog	1	
8	3/16S32034	Screw, for 244111	1	
9	244081	Slide Block Adjusting	1	
10	3/16S32025	Lock Bolt, for 244091	2	
11	11/64W15103	Washer, for 244091	2	
12	244091	Stud Slide Block Adjusting Support	2	
13	3/8N24201	Lock Nut, for 244091	2	
14	244122	Throat Plate	1	
15	9/64S40043	Screw, for 244122	3	
16	246081	Ball	1	
17	4B3x12	Bolt, for 246081(M3x0.5x12L)	1	
18	1N3	Nut, for 246081(M3x0.5)	1	
19	3W3	Spring Lock Washer(M3)	1	
20	1W3	Washer, for 246081(M3)	1	
21	11/64S40049	Screw, for 246021	1	
22	11/64W15103	Washer, for 246021	1	
23	246021	Knife Bracket	1	
24	246032	Knife Bracket Pin	1	
25	246042	Bushing, for 246032	1	
26	246051	Knife Tension Spring	1	
27	9/64S40502	Screw, for 246042	1	
28	246061	Knife Moving	1	
29	1/8S40003	Screw, for 246061	2	
30	246071	Knife Stationary	1	
31	1/8S40003	Screw, for 246071	2	
32	245561	Knife Cover	1	
33	1/8S40006	Screw, for 245561	2	



13

From the library of: Diamond Needle Corp

(6) MOTOR PARTS (For Totally Enclosed Type Motor)

(6) MOTOR I

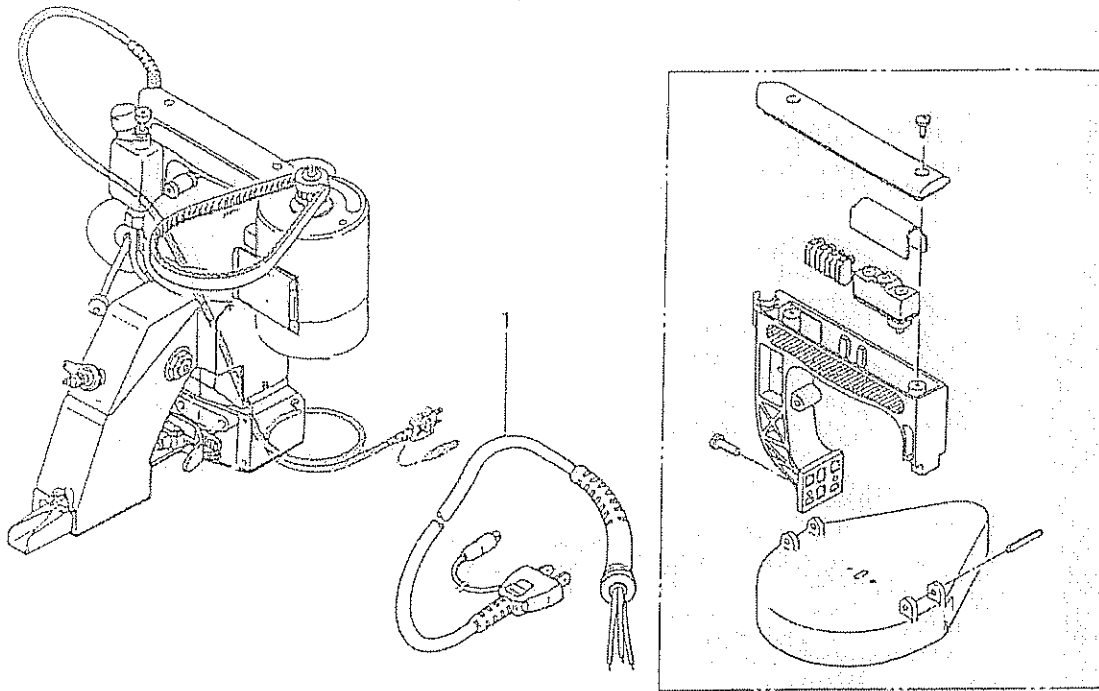

Key No.	Part No.
1	C04001 C04003 C04004 C04005 C04006 C04007 C04009
3	F01001
4	241083
5	11/64S40
6	C01021 C01022 C01023
7	C08008
8	C07004
9	241074
10	15/64S2800
11	11/64S400
12	8S3x0.5

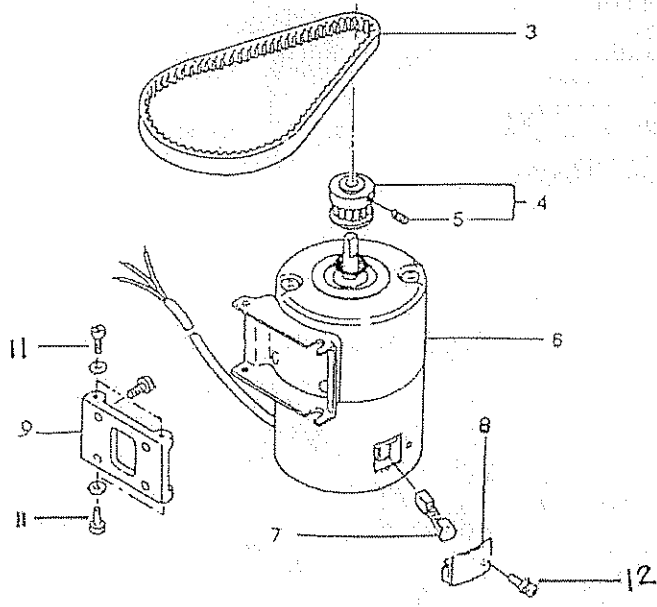

From the library of: Diamond Needle Corp



(6) MOTOR PARTS (For Totally Enclosed Type Motor)

Key No.	Part No.	Description	Q'ty	Remarks
1	C04001	Cabtyer Cord, with Plug(Standard Type)	1	
	C04003	Cabtyer Cord, with Plug(American Type)	1	
	C04004	Cabtyer Cord, with Plug(British Type)	1	
	C04005	Cabtyer Cord, with Plug(German Type)	1	
	C04006	Cabtyer Cord, with Plug(French Type)	1	
	C04007	Cabtyer Cord, with Plug(Australian Type)	1	
	C04009	Cabtyer Cord, with Plug(for DC Motor)	1	
3	F01001	Timing Belt	1	
4	241083	Motor Pulley	1	(5)
5	11/64S40504	Screw, for 241083	2	
6	C01021	Universal Motor (220V)	1	(7,8)
	C01022	Universal Motor (240V)	1	(7,8)
	C01023	Universal Motor (110V)	1	(7,8)
7	C08008	Carbon Brush, for AC Motor	2	
8	C07004	Cap	2	
9	241074	Motor Base	1	
10	15/64S28004	Screw, for 241074	4	
11	11/64S40049	Screw for Motor	4	
12	8S3x0.5	Screw for cap		

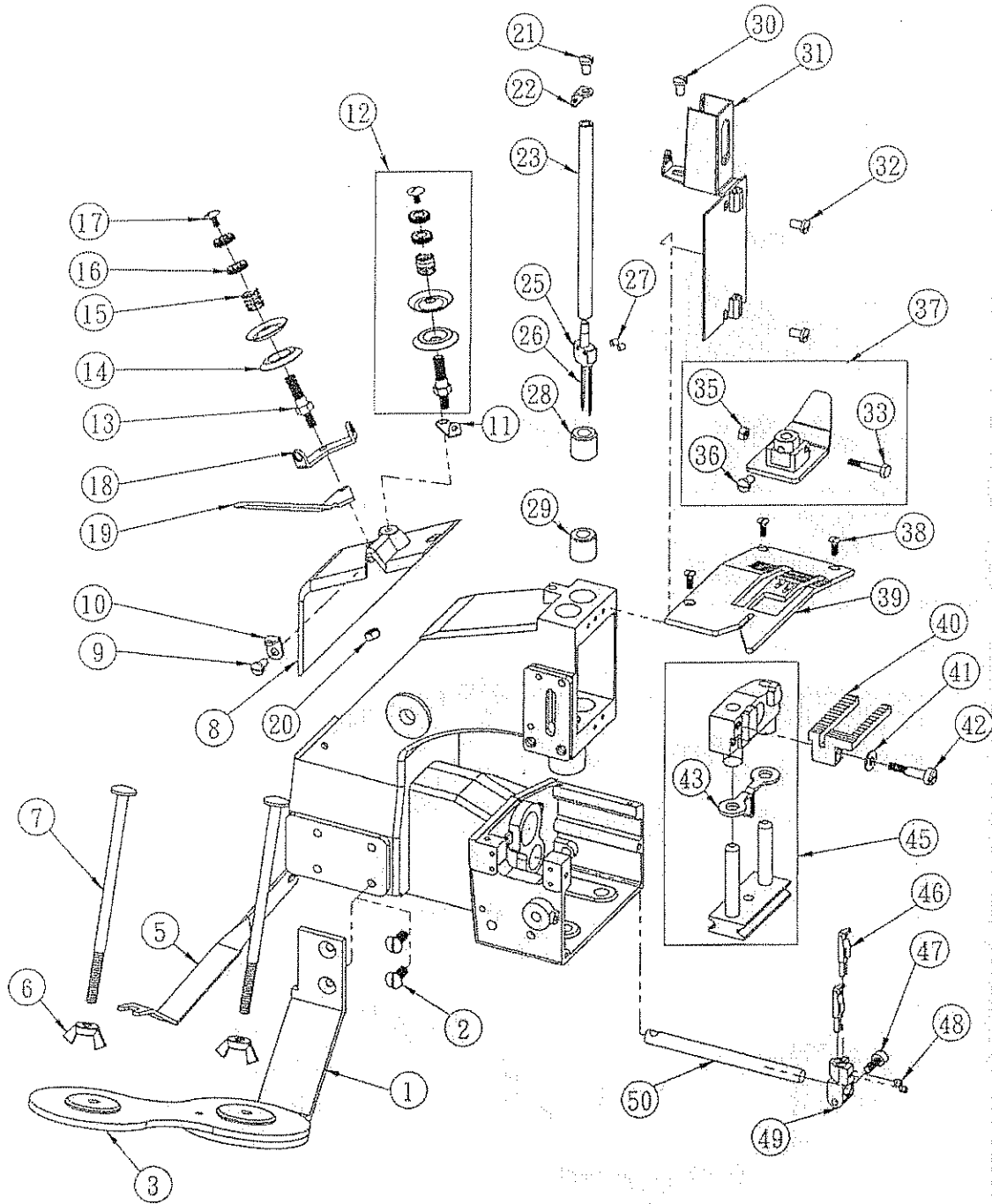

Key No.	
1	245045
2	15/64S
3	345045
5	345045
6	1N6
7	245055
8	245015
9	11/64S
10	245261
11	245071
12	245081
13	245081
14	065261
15	245101
16	245091
17	9/64S4
18	345045
19	345045
20	3/16N
21	11/64S
22	345045
23	242121
25	345047
26	B0100
27	9/64S4
28	242211
29	242211
30	11/64S
31	245031
32	9/64S4
33	9/64S4
35	9/64N
36	11/64S
37	242231
38	9/64S4
39	244121
40	244111
41	11/64V
42	3/16S3
43	245391
45	244011
46	243101
47	11/64S
48	9/64S4
49	243091
50	243031

(7) SPECIAL PARTS FOR AK-7A-2

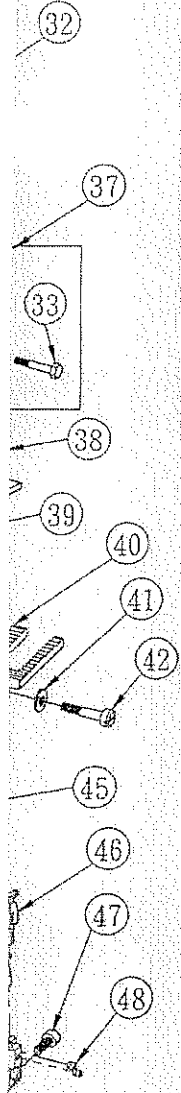

Key No.	Part No.	Description	Q'ty	Remarks
1	245042-2	Thread stand	1	
2	15/64S28028	Screw	2	
3	345042	Thread stand	1	
5	345043	Thread stand	1	
6	1N6	Nut	2	
7	245052	Thread Cone Clamping Rod	2	
8	245014-2	Top Cover	1	
9	11/64S40006	Screw	1	
10	245261	Thread Eyelet	1	
11	245071	Thread Tension Eyelet	1	
12	245081A	Thread Tension Assembly	2	
13	245081	Tension Post	2	
14	065261	Tension Disc	4	
15	245101	Tension Spring	2	
16	245091	Tension Nut	4	
17	9/64S40011	Screw	2	
18	345044	Thread Guide Plate	1	
19	345045	Thread Guide Plate	1	
20	3/16N28205	Nut	1	
21	11/64S40005	Screw	1	
22	345046	Thread Eyelet	1	
23	242121A-2	Needle Bar	1	
25	345047	Needle Holder	1	
26	B01002-2	Needle ( BC*5 #25 )	2	
27	9/64S40502	Screw	2	
28	242212	Bushing For Needle Bar	1	
29	242212-2	Bushing For Needle Bar	1	
30	11/64S40005	Screw	1	
31	245033-2	Needle Bar Guard	1	
32	9/64S40065	Screw	2	
33	9/64S40055	Screw	1	
35	9/64N40101	Nut	1	
36	11/64S40005	Screw	1	
37	242231A-2	Presser Foot Assembly	1	
38	9/64S40043	Screw	3	
39	244122-2	Throat Plate	1	
40	244111-2	Feed Dog	1	
41	11/64W15103	Washer	1	
42	3/16S32034	Screw	1	
43	245391	Oil Felt	1	
45	244011A-2	Feed Dog Carrier Block Assembly	1	
46	243102-2	Looper	2	
47	11/64S40089	Screw	1	
48	9/64S40502	Screw	2	
49	243092-2	Looper Rocker	1	
50	243032-2	Looper Rocker Shaft	1	



(8) CREPE TAPE BINDING AND CUTTER PARTS (Special Order Parts)

(8) CREPE T

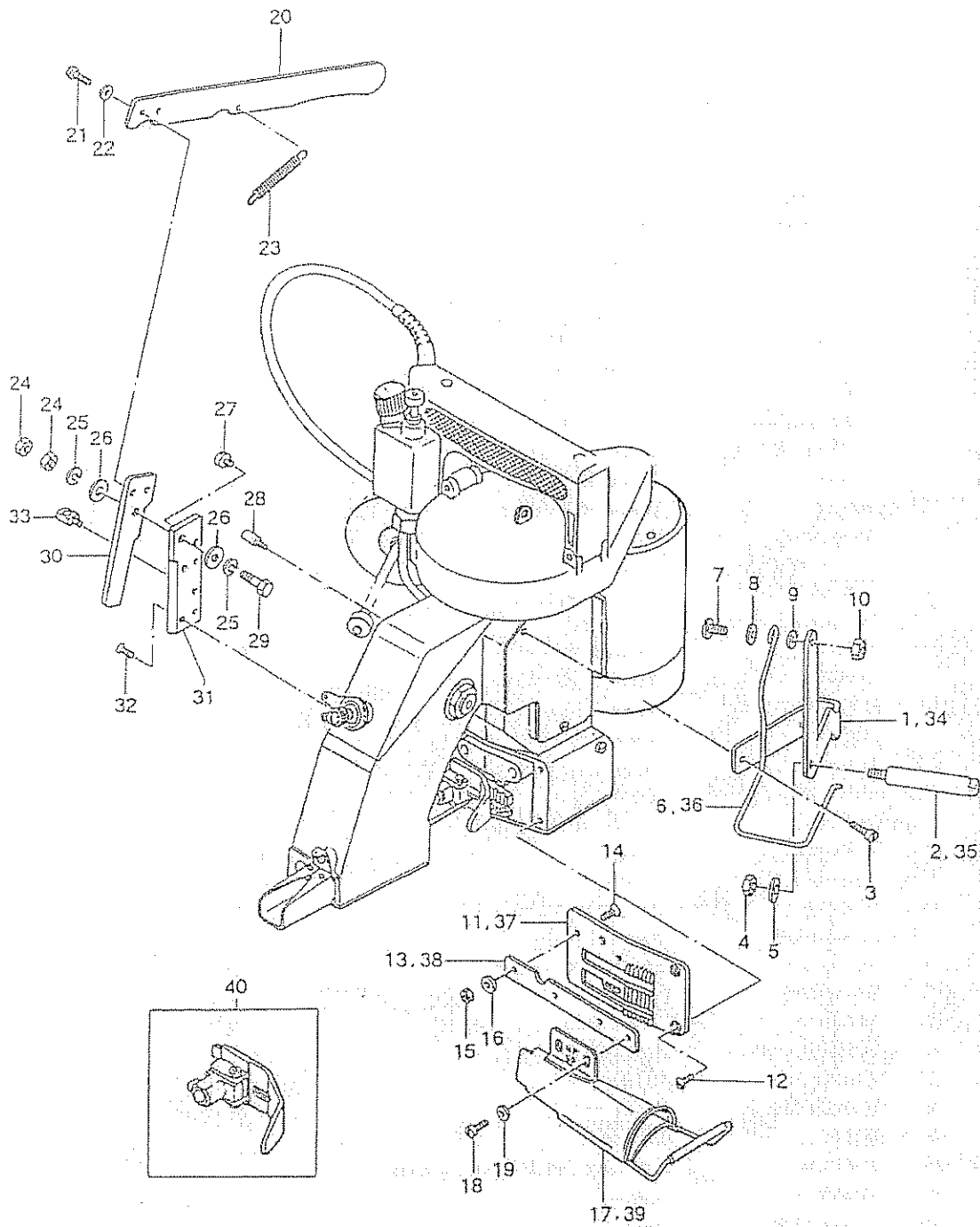

Key No.	Part No.
1	247071
2	247091
3	9/64S4003
4	1N6
5	2W6
6	247081
7	11/64S400
8	1/4W0320
9	1/4W1510
10	11/64N402
11	244132
12	9/64S4004
13	247051
14	9/64S4004
15	9/64N4010
16	2W4
17	247061
18	9/64S4005
19	2W4
20	247031
21	11/64S400
22	11/64W10
23	247041
24	15/64N282
25	3W6
26	2W6
27	11/64S400
28	3/16S3202
29	247021
30	247011
31	247001
32	1/8S40003
33	183251
34	247073
35	247092
36	247082
37	244133
38	247052
39	247063
40	242261A

(8) CREPE TAPE BINDING AND CUTTER PARTS (Special Order Parts)

Key No.	Part No.	Description	Qty	Remarks
1	247071	Crepe Tape Bracket	1	
2	247091	Crepe Tape Hanger Stud	1	
3	9/64S40035	Screw, for 247071	2	
4	1N6	Nut, for 247091 (M6)	1	
5	2W6	Washer, for 247091 (M6)	1	
6	247081	Crepe Tape Supporter	1	
7	11/64S40015	Screw, for 247071	1	
8	1/4W03205	Spring Washer, for 247071	1	
9	1/4W15105	Washer, for 247071	1	
10	11/64N40203	Nut, for 247071	1	
11	244132	Throat Plate	1	
12	9/64S40043	Screw, for 244132	3	
13	247051	Holder, for crepe tape binder	1	
14	9/64S40043	Screw, for 247051	2	
15	9/64N40101	Nut, for 247051	2	
16	2W4	Washer, for 247051(M4)	2	
17	247061	Crepe Tape binder	1	
18	9/64S40054	Screw, for 247061	2	
19	2W4	Washer, for 247061(M4)	2	
20	247031	Cutter Lever	1	
21	11/64S40046	Screw, for 247011	2	
22	11/64W10101	Washer, for 247011	2	
23	247041	Screw, for 247031	1	
24	15/64N28206	Nut, for 247021	2	
25	3W6	Spring Lock Washer, for 247021,(M6)	2	
26	2W6	Washer, for 247021, (M6)	2	
27	11/64S40029	Stopper Screw, for 247011	1	
28	3/16S32026	Stopper Screw, for 247031	1	
29	247021	Hinge Pin	1	
30	247011	Knife, Moving	1	
31	247001	Knife, Stationary	1	
32	1/8S40003	Screw, for 247001	4	
33	183261	Spring Hook	1	
34	247073	Crepe Tape Bracket	(1)	for Crepe Tape width 70 mm
35	247092	Crepe Tape Hanger Stud	(1)	
36	247082	Crepe Tape Supporter	(1)	
37	244133	Throat Plate	(1)	
38	247052	Holder, for crepe tape binder	(1)	
39	247063	Crepe tape Binder	(1)	
40	242261A	Presser Foot Assembly	(1)	

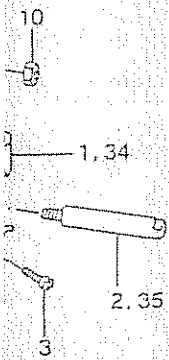

From the library of: Diamond Needle Corp

## NUMERICAL INDEX OF PARTS

PART NO.	PAGE	PART NO.	PAGE	PART NO.	PAGE	PART NO.	PAGE	PART NO.	PA
065261	11-14	242261A	25-40	2245461	13-20	OTHER ITEMS		SCREW	
065401	13-15			45462	23-22				
065561	15-34	243012	17-17	245471	13-18	6A04001	15-14	1/8S40003	19-
185261	25-33	243021	13-27	245481	11-25	B01002	15-33		25-
205131	14-6,17-4	243032	17-16	245491	15-20	C01021	21-6	1/8S40006	13-
						C01022	21-6		
205171	15-29	243041	17-7	245541	13-24	C01023	21-6	3/16S28001	14-
		243061	17-8			C02001	13-6	3/16S28029	14-
241024	13-3,23-1	243071	17-5	245561	19-32	C02006	13-6	3/16S32025	19-
241024A	13-2	243081	17-10	246011	19-5	C04001	21-1	3/16S32026	25-
241024AS	13-1	243092	17-12	246021	19-23			3/16S32031	19-
						C04003	21-1		
241024B	13-35	243102	17-14	246032	19-24	C04004	21-1	3/16S32034	19-
241024BS	13-34	243111	17-20	246042	19-25	C04005	21-1	9/64S40001	17-
241074	21-9	243121	17-1	246051	19-26	C04006	21-1	9/64S40004	23-
241083	21-4	243131	17-3	246061	19-28	C04007	21-1	9/64S40005	11-
241092	14-1	244011A	19-1	246071	19-30				11-
						C04009	21-1		23-
241111	13-25	244081	19-9	246081	19-16			9/64S40011	11-
241102	14-7	244091	19-12	247001	25-31	C07004	21-8		19-
241122	13-13	244102	19-3	247011	25-30	C08008	21-7	9/64S40035	17-
241131	14-3	244111	19-7	247021	25-29	D03003	13-8	9/64S40043	19-
241151	13-30	244122	19-14	247031	25-20				25-
						D07009	23-23		
241161	14-5	244132	25-11	247041	25-23	D07021	13-16,23-13	9/64S40052	23-
241212	23-3	244133	25-37	247051	25-13			9/64S40054	25-
241223	23-10	245014	11-9	247052	25-38			9/64S40055	15-
241231	23-8	245022	11-23	247061	25-17	D07022	23-18	9/64S40065	11-
241242	23-6	245033	11-18	247063	25-39	D07023	23-19	9/64S40065	11-
								9/64S40065	11-
241253	23-12	245042	11-1	247071	25-1	D07024	23-20	9/64S40065	11-
242011	14-9	245052	11-7	247073	25-34	F01001	21-3	11/64S40001	14-
242011A	14-8	245071	11-32	247081	25-6	K01001	11-6	11/64S40002	15-
242031	15-19	245081A	11-12	247082	25-36	8FN2-4x135K	23-21	11/64S40003	15-
242041	15-18	245081	11-13	247091	25-2	8FU2-6x60F	13-10		17-
								11/64S40004	15-
242051A	15-25	245091	11-16	247092	25-35	8FU2-6x70F	23-17		
242071	15-24	245101	11-15			8FU2-6x90F	13-9	11/64S40005	11-
242081	15-22					8FU2-6x95F	23-16	11/64S40006	11-
242101A	15-28	245162	13-28			EW-6.5	13-33	11/64S40009	
242121A	15-31	245171	13-32					11/64S40015	25-
								11/64S40029	25-
242131	15-32	245181	11-28						
242161	15-46	245201	11-8					11/64S40046	25-
242172	15-35	245211	15-17					11/64S40049	19-
242181	15-38	245222	11-21					11/64S40084	15-
242191	15-40	245231	15-23					11/64S40089	17-
								11/64S40502	14-
242201	15-37	245261	11-29						
242212	13-21	245271	13-29					11/64S40504	21-
242222	13-23	245302	11-26					15/64S28004	21-
242231A	15-41	245371	15-27					15/64S28021	13-
242233A	15-45	245391	19-2					15/64S28028	11-
								15/64S28032	23-

From the library of Diamond Needle Corp.



## NUMERICAL INDEX OF PARTS

GE	PART NO.	PAGE	PART NO.	PAGE	PART NO.	PAGE	PART NO.	PAGE
MS	SCREW		15/64S28524	17-18				
14			4B3x12	19-17				
33	1/8S40003	19-29,19-31	6S5x15	13-11				
6		25-32	9S2.6x10	13-36				
6	1/8S40006	13-31,19-33	11/64S40049	21-11				
6			11/64S40009-1	15-50				
6	3/16S28001	14-2	NUT					
6	3/16S28029	14-10	1N3	19-18				
6	3/16S32025	19-10	1N4	13-19				
6	3/16S32026	25-28	1N6	11-3,25-4				
1	3/16S32031	19-6						
1	3/16S32034	19-8	1N8	14-12				
1	9/64S40001	17-15	3/8N24201	19-13				
1	9/64S40004	23-4	5/8N18101	15-21				
1	9/64S40005	11-10,11-24	9/64N40101	15-43,25-15				
1		11-27,17-22						
1		23-9,23-24						
1	9/64S40011	11-17,13-4	11/64N40201	17-9				
1		19-4,23-2	11/64N40203	25-10				
1	9/64S40035	17-21,25-3	15/64N28206	25-24				
1	9/64S40043	19-15,25-12						
1		25-14	WASHER					
1	9/64S40052	23-5	1W3	19-20				
1	9/64S40054	25-18	2W4	25-16,25-19				
1	9/64S40055	15-42	2W6	25-5				
1	9/64S40065	11-20,11-22		25-26				
1	9/64S40502	13-14,13-22	3W3	19-19				
1		13-26,19-27						
1	11/64S40001	14-11	3W6	25-25				
1	11/64S40002	15-36,17-6	5W8	15-13				
1	11/64S40003	15-30,15-39	1/4WD3205	25-8				
1		17-2	1/4W15105	25-9				
1	11/64S40004	15-26	11/64W10101	25-22				
1	11/64S40005	11-19,15-44	11/64W15103	15-16,15-49				
1	11/64S40006	11-30		19-11,19-22				
1	11/64S40009	17-11	E03014	13-17,23-14				
1	11/64S40015	25-7						
1	11/64S40029	25-27						
1	11/64S40046	25-21						
1	11/64S40049	19-21						
1	11/64S40084	15-15						
1	11/64S40089	17-13						
1	11/64S40502	14-4						
1	11/64S40504	21-5						
1	15/64S28004	21-10,23-7						
1	15/64S28021	13-12						
1	15/64S28028	11-2						
1	15/64S28032	23-11						

From the library of: Diamond Needle Corp

# SCREW , NUT & WASHER

FULL SIZE

