

DESCRIPTIVE LIST
OF PARTS
FOR
MERROW[®]
CLASS MG and CLASS M
Machines

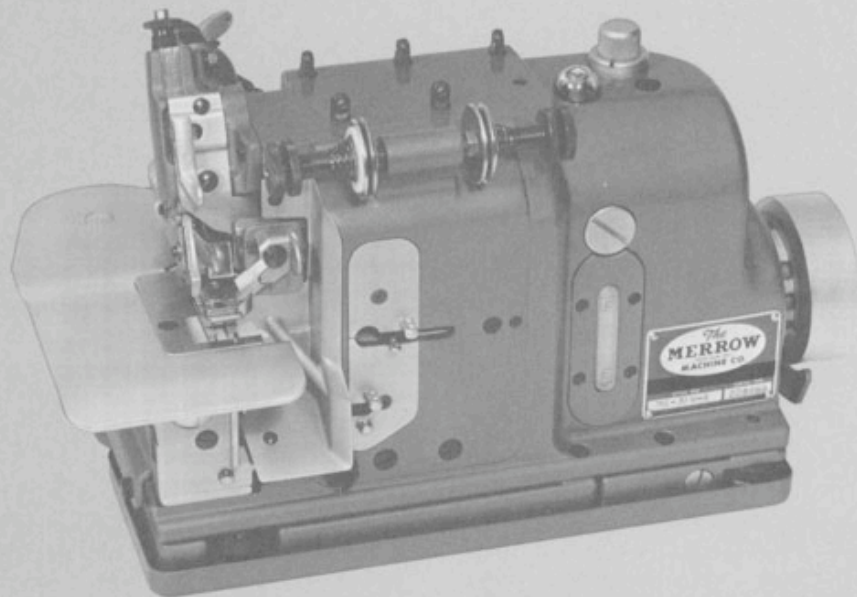

THE MERROW[®] MACHINE COMPANY
240 Day St., Newington, CT 06111
Telephone (203) 666-0109
Telex 994473 MERROW, NEWI

THE MERROW MACHINE COMPANY

240 DAY STREET, NEWINGTON, CONNECTICUT 06111



MAIN OFFICE AND FACTORY

MANUFACTURING SUBSIDIARY



Franklin Industries, Incorporated, Lavonia, Georgia

INTRODUCTION

This book contains a descriptive list of many parts in general use in the Merrow Class MG and M Overseaming Machines, together with illustrations. This list includes parts with prefix M, prefix A, and prefix 6 which are commonly used on Class MG and M Machines. All moving parts subject to friction and wear have been carefully designed and accurately formed to give them maximum utility, durability, and interchangeability for continuous and perfect operation at high speed.

Over a period of years, numerous parts for our Machines have been designed for special uses and since their application is limited, these parts are not listed herein. It is anticipated that new parts will be developed in the future as style and fashion change. Your individual problems will receive our prompt attention.

The Class MG and M Machines overseam and trim simultaneously and form one of the following stitch formations: a one-thread overseam; a two-thread overseam or finish; a three-thread overseam or finish, and a three or four-thread tight needle thread seam.

These machines are largely used on a great variety of knitted and woven fabrics from the lightest to the heaviest, either for sewing two or more pieces of fabric together or for finishing the edges of a single piece of fabric, all in a most perfect manner.

We make other Classes of machines including Class 70 Butted Seaming Machines, Plain Crochet Machines, Blanket Hemming Machines, and Shell Stitch Crochet Machines which have been long and favorably known and used by manufacturers throughout the world.

HOW TO ORDER

Send parts order to your nearest Merrow Distributor or The Merrow Machine Company, 240 Day Street, Newington, Connecticut, 06111 U.S.A. Telephone (203) 666-0109. Telex 994473 Newi

When ordering replacement parts, include the **Style** of the machine, the **Name** of the part, and the **letters** and **numbers** stamped on the part. The stamping on a particular part is insufficient information without giving the name of the part. All enameled parts will be furnished in gray or green.

We keep a description card on each machine listing the parts in the machine as it leaves the factory. If difficulty is experienced in selecting the proper part number desired, we expect to be able to make proper selection from our records if given the following information:

- 1) The **Name** of Part
- 2) The **Style** and **Serial Number** of Machine
- 3) Special information if included below:
 - a) Needle Plates – specify:
The width of finish desired, whether long or short finger, and size of Needle used. The part number of all Needle Plates is stamped on the underside of the plate.
 - b) Loopers – specify:
Upper or lower, one, two, three or four thread stitch. Number of Looper is stamped on the shank near the butt end.
 - c) Parts for Feeding Mechanism – specify:
Front or rear feed if machine has differential (gathering) feed.

If the machine Class or Style is not listed for a part, the part may be used in Class M or MG machines.

USE OF NUMERICAL INDEX

On the following pages are listed the Part Numbers arranged numerically in order of the Key to Part Numbers.

SAMPLE				
Part No.	FRAME	Part Name	<u>Class</u>	Illust.
M-1-1	Generally Used	Use of Part	M	Page
		Variation of Part Number		
		Key to Part Number		
		Prefix of Part Number		

CONTENTS

	Page
How to Order, Use of Numerical Index	1
Numerical Index Frame M-1-1 Gray through Main Cam Race M-375-3 with Illustrations	2-36
Assemblies, Miscellaneous	37
Needle Terms, Needles	38
Loopers with Illustration, Carbide Tipped Cutters, Rubber Tipped Feed Dogs	39
Common Nuts and Screws, Springs, Pins	40
Tools — Accessories with Illustration, Main Cams — Class MG & M	41
Illustration Styles M-3Q, M-3Q-3	42
Styles M-3Q, M-3Q-3 Parts, Alphabetical Index	43
Illustration Chain Cutter Assembly	44
Chain Cutter Parts, Alphabetical Index	45-47
Trimmer Assemblies	48
Illustration Cutter Grinder, Thread Stand, with Parts Listing	Inside Back Cover

Front View

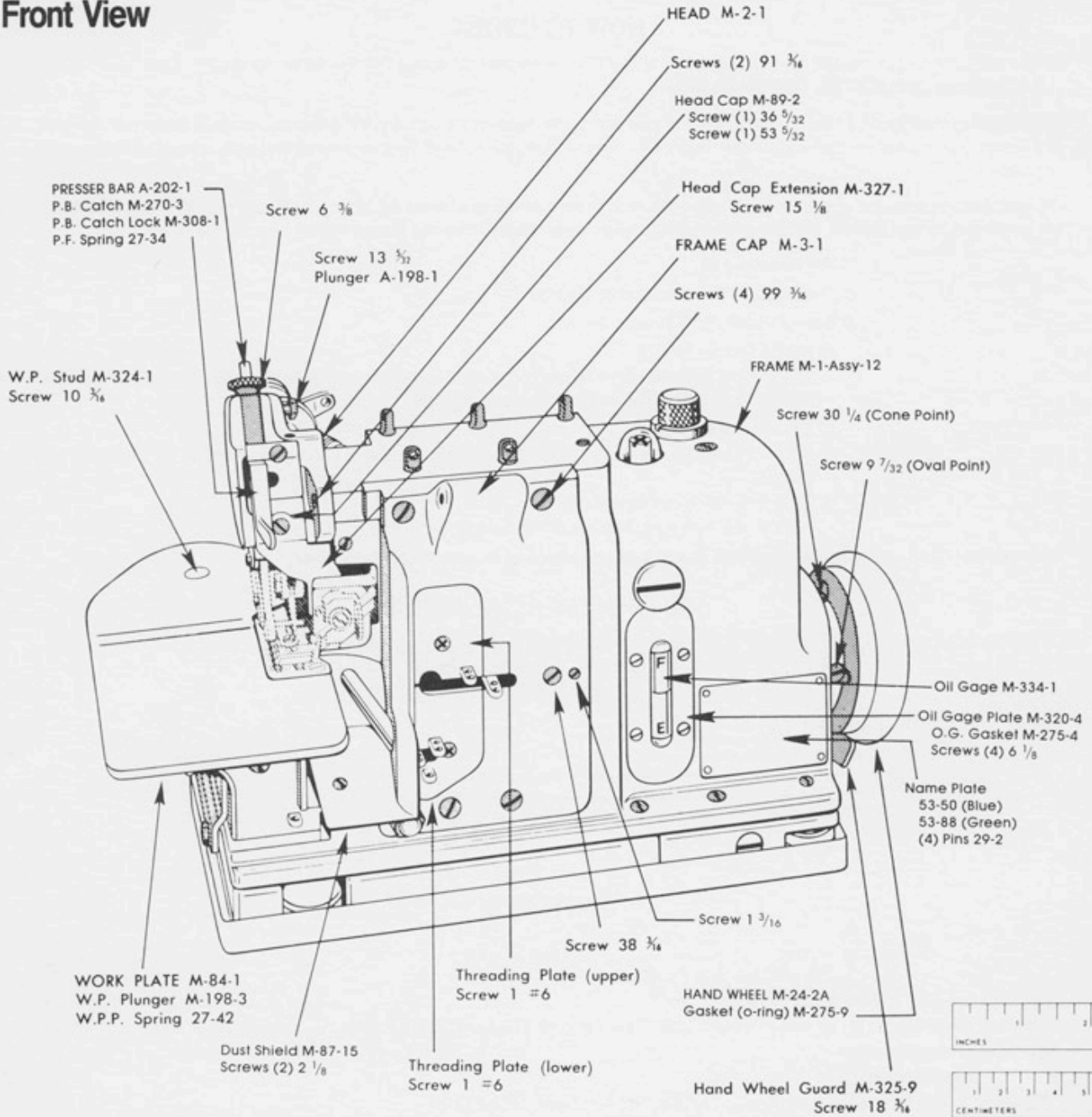

Part No.
M-1-1 Gray
M-1-3 Gray
M-1-5 Gray
M-1-Assy-11 Green
M-1-Assy-12 Green
M-2-1 Green/Gray
M-2-2 Green/Gray
M-2-3 Green/Gray
M-2-6 Green/Gray
M-2-8 Green
M-3-1 Green/Gray

FRAME

Generally used
 Used on shirring machine, Style M-3DW-SI
 Extra oiling features
 Extra oiling to feed mechanism
 Generally used

HEAD

Generally used.
 Similar to M-2-1, except hole for T. Guide 6-61-E
 Similar to M-2-1, except holes for T. Guides M-61-7 and M-61-8
 Used on Large Wheel Foot machine
 Extra clearance for N.T. Takeup A-112-2

FRAME CAP

Screws (2) 91 3/16

Screws (4) 99 3/16

Class
M

M
MG
MG

Style

4D-45, 60 Men's
4D-45 Ladies'

MG-3DW-7

Illust.
Page 2

2

3

4

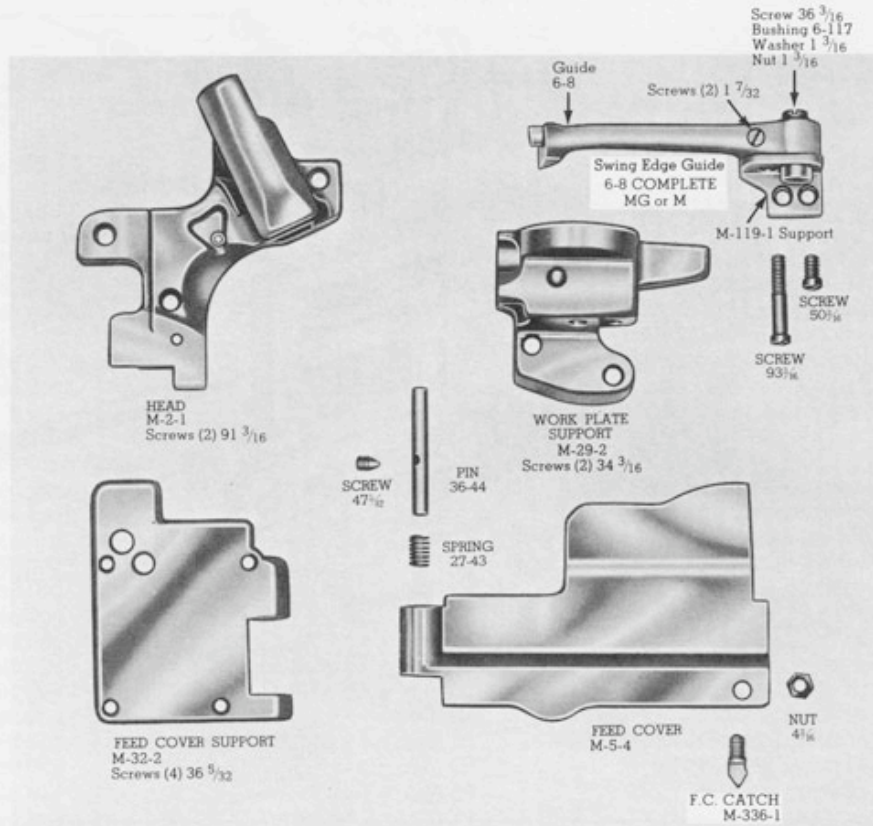

Part No.	FEED COVER	Style	Illust. Page
M-5-3 Green/Gray	Used with F.C. Catch M-336-1, Nut 4 ³ / ₁₆	2DH-1, 3DW-2, 4	3,36
M-5-4 Green/Gray	Same as above	2DNR-1, 3DW	
M-5-6 Green/Gray	Same as above	MG-3DW-7	
6-8 Complete	Includes: Guide 6-8, (2) Stop Screw 1 ⁷ / ₃₂ , Bushing 6-117, Pivot Screw 36 ³ / ₁₆ , Washer 1 ³ / ₁₆ , Nut 1 ³ / ₁₆ , Support M-119-1, Support Screw (Long) 93 ³ / ₁₆ , (Short) 50 ³ / ₁₆		3
M-24-1 Green/Gray	Includes: Gasket (O-Ring) M-275-9	Screw (Cone Point) 30 ¹ / ₄	7
M-24-2A Alum.	Includes: Gasket (O-Ring) M-275-9 Handwheels listed above used with H.W. Guard M-325-9, Screw 18 ³ / ₁₆	Screw (Oval Point) 9 ⁷ / ₃₂	2,6
M-29-2 Green/Gray	Generally used	Screws (2) 34 ³ / ₁₆	3,36
M-29-3 Gray	Used on shirring machine, Style M-3DW-SI		
M-29-8 Green/Gray	Used on extra oiling Frames M-1-5, M-1-Assy-11		
M-29-9 Green/Gray	Similar to M-29-2, except W.P. Support area relieved, used without Work Plate or Feed Cover		
M-30-3 Green/Gray	Includes: Screw 11 ³ / ₈ , Gasket (O-Ring) M-275-12	Screws (2) 83 ³ / ₁₆	30
M-31-2 Green/Gray		Screws (3) 83 ³ / ₁₆	30
M-32-2 Green/Gray	Generally used	Screws (4) 36 ⁵ / ₃₂	3,36
M-32-3 Gray	Used on shirring machine, Style M-3DW-SI		
M-33-1 Green/Gray		Style	6,7
M-33-3 Green/Gray		2DNR-1, 3DR, 3DU	
M-33-4 Green/Gray		2DH-1, 3DW	
		3DW-2, 3, 4, 7	6,7

Frame Cap Assembly — Class MG

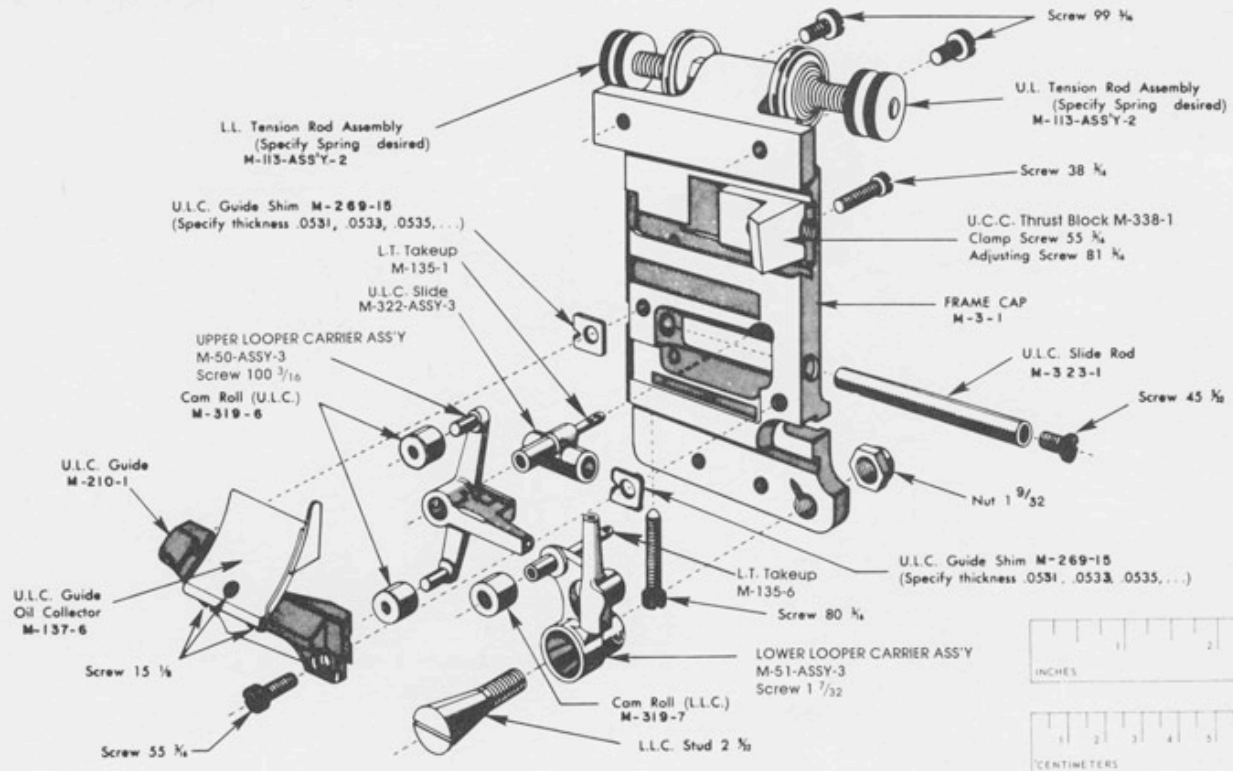

Frame Cap Assembly — Class M

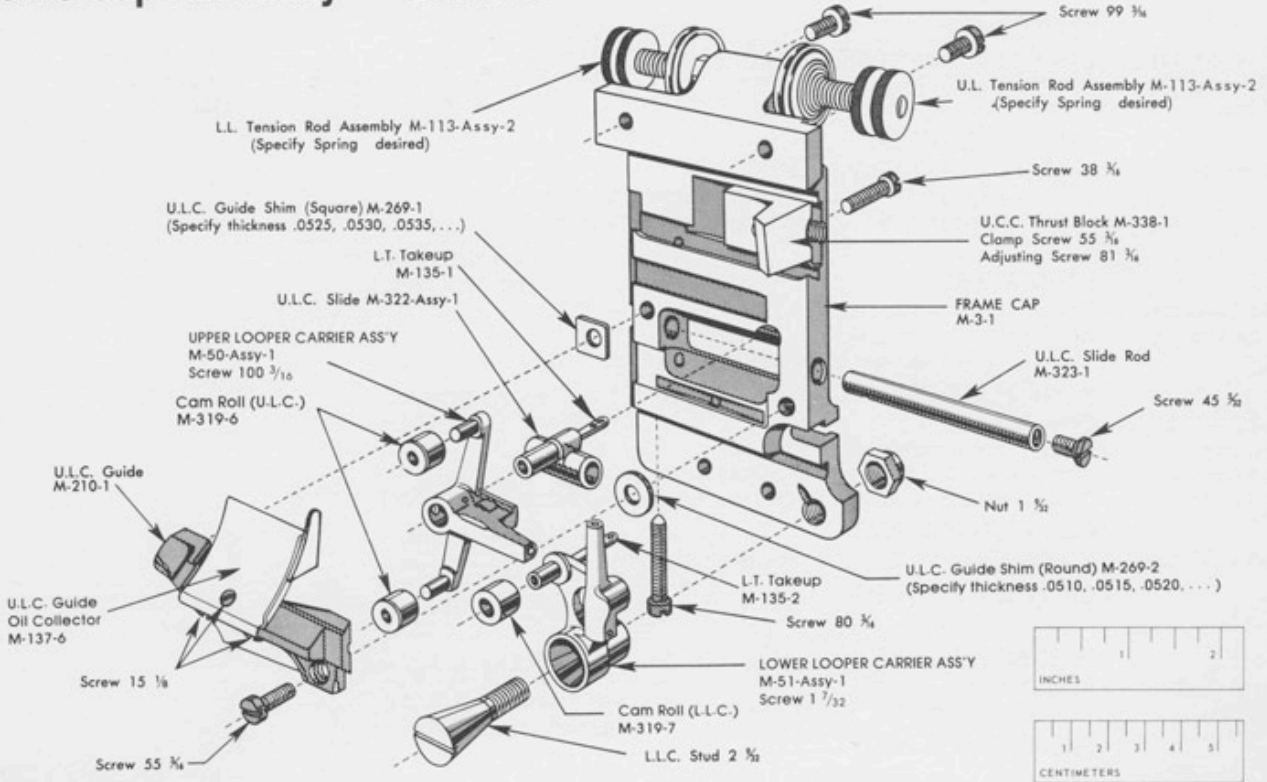

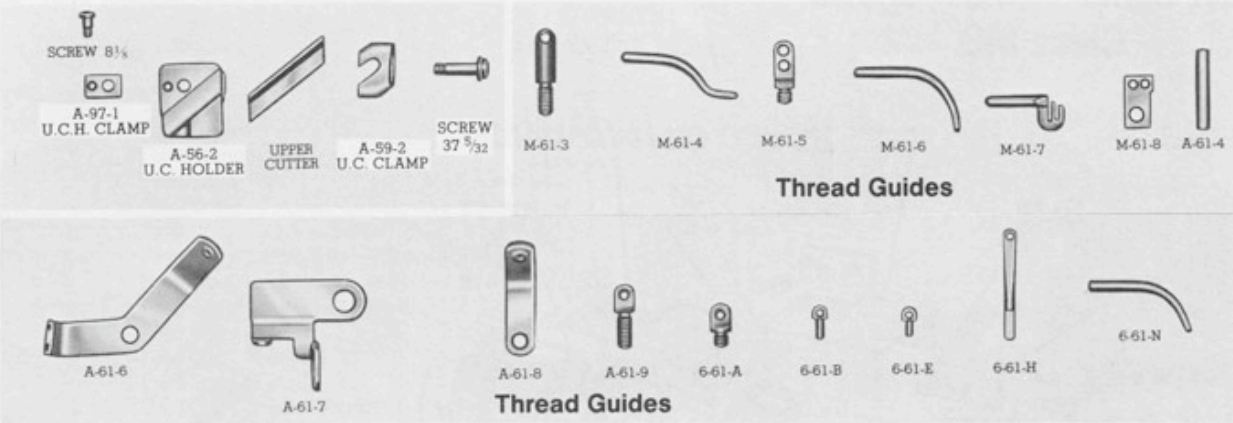

Part No.	Description	Screw	Class	Illust. Page
M-50-Assy-1	UPPER LOOPER CARRIER Includes: Pin 36-47	Screw 100 ³ / ₁₆	M	4
M-50-Assy-3	Includes: Pin 36-47		MG	4
M-51-Assy-1	LOWER LOOPER CARRIER Includes: Takeup M-135-2, Pin 36-39, Stud 2 ⁹ / ₃₂ , Nut 1 ⁹ / ₃₂	Screw 17 ¹ / ₃₂	M	4
M-51-Assy-3	Includes: Same as above, except Takeup M-135-6		MG	4
M-52-Assy-1	UPPER CUTTER CARRIER Includes: Cap M-53-1, Screws (2) 41 ⁵ / ₃₂ , Pin (2) 36-41, Plate M-320-3	Screw 88 ¹³ / ₁₆		6,7
M-54-1	UPPER CUTTER CARRIER STUD Used with Bushing (Left) M-337-1 and Bushing (Right) M-337-2			6,7
M-55-1	UPPER CUTTER CARRIER ECCENTRIC BLOCK Generally used		M	7
M-55-4	Generally used		MG	6
A-56-1	UPPER CUTTER HOLDER Used with narrow Upper Cutter like 6-90	Screw 8 ¹ / ₈		5
A-56-2	Used with wide Upper Cutter like A-90-1			
A-56-3	Similar to A-56-1, except relieved to allow for wider trimming			
A-56-4	Similar to A-56-2, except relieved to allow for wider trimming			
A-59-1	UPPER CUTTER CLAMP Used with narrow Upper Cutter like 6-90, Screw 38 ⁵ / ₃₂			5
A-59-2	Used with wide Upper Cutter like A-90-1, Screw 37 ⁵ / ₃₂			
A-59-3	Similar to A-59-2, except has threading hole, Screw 37 ⁵ / ₃₂			
M-61-1	THREAD GUIDE Single eye, used on Threading Plate			5
M-61-2	Double eye, used on Threading Plate			
M-61-3	Spring Anchor, used with Spring 27-35		M-3DW-SI	
M-61-4	Double eye, used with N.T. Take-up 6-112-V			
M-61-5	Double eye		4D-45 Ladies'	
M-61-6	Double eye		4D-45, 60 Men's	
M-61-7	Used with N.T. Take-up A-112-8, Head M-2-3		4D-45 Ladies'	
M-61-8	Used with N.T. Take-up A-112-8, Head M-2-3, Screw 9 ¹ / ₈		4D-45 Ladies'	
A-61-4	Tube in Head, used with N.T. Take-up A-112-2, 3, 6, 7			
A-61-6	Double ended Thread Guide			
A-61-7	Used on top of Frame		2DNR-1	
A-61-8	Similar to A-61-6, except single ended			5
A-61-9	Similar to A-61-8, except longer, used with Nut 5 ³ / ₁₆			5
A-61-10	Similar to A-61-8, except shorter, used to prevent thread from jumping out of Tension Discs during stitching		M-3Q, M-3Q-3, 3U	5
6-61-A	Screw eye top of Frame			5
6-61-B	Single eye for Lower Cutter Holder Support			5
6-61-E	Single eye for needle thread in Head, use with N.T. Take-up A-112-1			5
6-61-H	Used with N.T. Take-up A-112-5			5
6-61-N	Used with N.T. Takeup A-112-1			5

From the library of: Diamond Needle Corp

Main Cams — Main Shafts Class MG

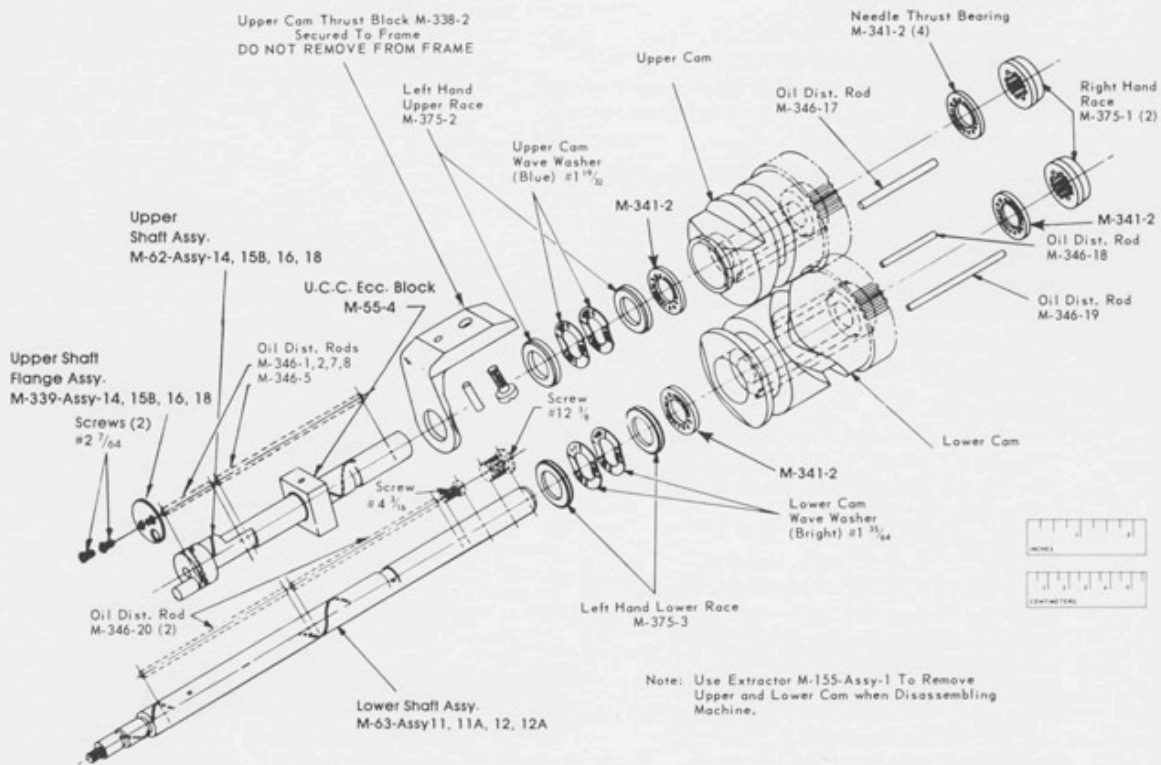
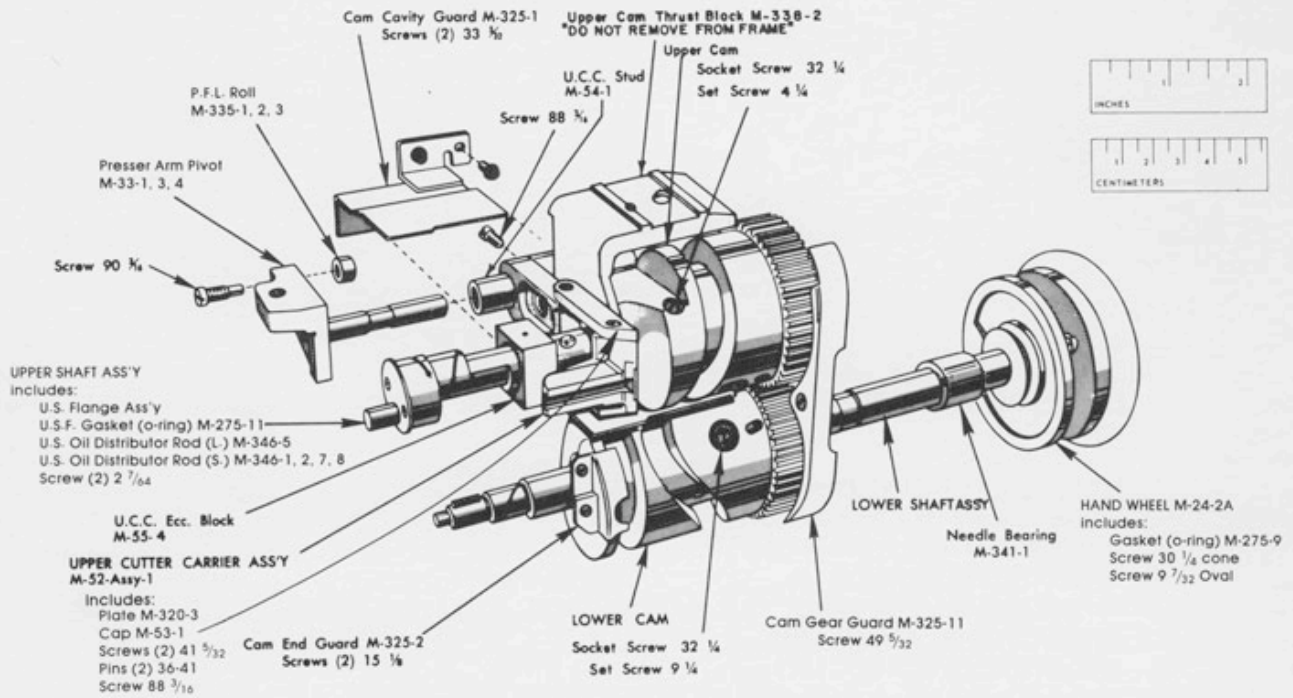

Main Cams — Main Shafts Class M

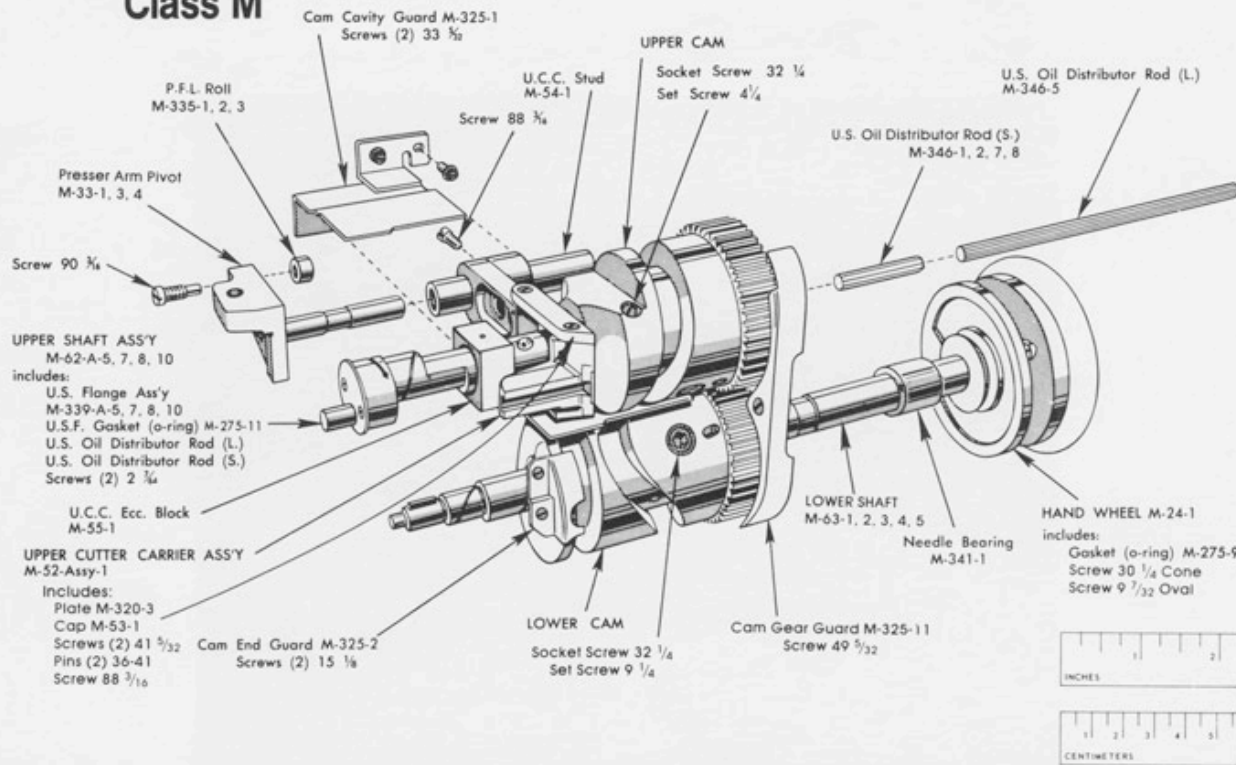

Illust. Page 6,7

UPPER SHAFT

Part No.	Flange	Flange Gasket (O-Ring)	O. Dist. Rod (Short)	O. Dist. Rod (Long)	Style
M-62-Assy-5	M-339-Assy-5	M-275-11	M-346 to fit	M-346-5	M-3DW
M-62-Assy-5B	M-339-Assy-5B	M-275-11	M-346 to fit	M-346-5	M-4D-45 Men's, Ladies'
M-62-Assy-7	M-339-Assy-7	M-275-11	M-346 to fit	M-346-5	M-4D-60 Men's
M-62-Assy-8	M-339-Assy-8	M-275-11	M-346 to fit	M-346-5	M-2DNR-1
M-62-Assy-9	M-339-Assy-9	M-275-11	M-346 to fit	M-346-5	M-3DW-2, 3, 4
M-62-Assy-10	M-339-Assy-10	M-275-11	M-346 to fit	M-346-5	Formerly used in M-4DW-100
M-62-Assy-13	M-339-Assy-13	M-275-11	M-346 to fit	M-346-5	M-4DW-100
M-62-Assy-14	M-339-Assy-14	M-275-11	M-346 to fit	M-346-5	M-3DW-6
M-62-Assy-15	M-339-Assy-15	M-275-11	M-346 to fit	M-346-5	MG-3DW-6, MG 4DW-60
M-62-Assy-15B	M-339-Assy-15B	M-275-11	M-346 to fit	M-346-5	MG-3DW
M-62-Assy-16	M-339-Assy-16	M-275-11	M-346 to fit	M-346-5	MG-3DW, MG-2DNR-1,
M-62-Assy-18	M-339-Assy-18	M-275-11	M-346 to fit	M-346-5	MG-4D-45, Men's, Ladies'
					MG-3DW-7, MG-4DW-67,
					MG-4DW-107
					MG-3DW-2, 3, 4

LOWER SHAFT

Part No.	Feed	Feed Throw	Key	Nut	Style
M-63-1	Differential	Low	6-152-A	2 3/16	M-3DW
M-63-1A	Differential	Low	6-152-A	2 3/16	M-4D-45 Men's, Ladies'
M-63-2	Differential	High	6-152	2 3/16	M-4D-60 Men's
M-63-3	Non-Differential	Low	6-152-C	2 3/16	M-3DW-2, 3, 4
M-63-4	Non-Differential	High	6-152-B	2 3/16	M-1, M-3U
M-63-5	Differential	Low	6-152-A	2 3/16	M-2-2
M-63-Assy-11	Differential	Low	6-152-A	2 3/16	M-3DWL
*M-63-Assy-11A	Differential	Low	6-152-A	2 3/16	MG-3DW, MG-2DNR-1
M-63-Assy-12	Differential	High	6-152	2 3/16	Same as above
*M-63-Assy-12A	Differential	High	6-152	2 3/16	MG-3DW-2, 3, 4, 7
					Same as above

*Use with Handwheel M-24-2A

6,7

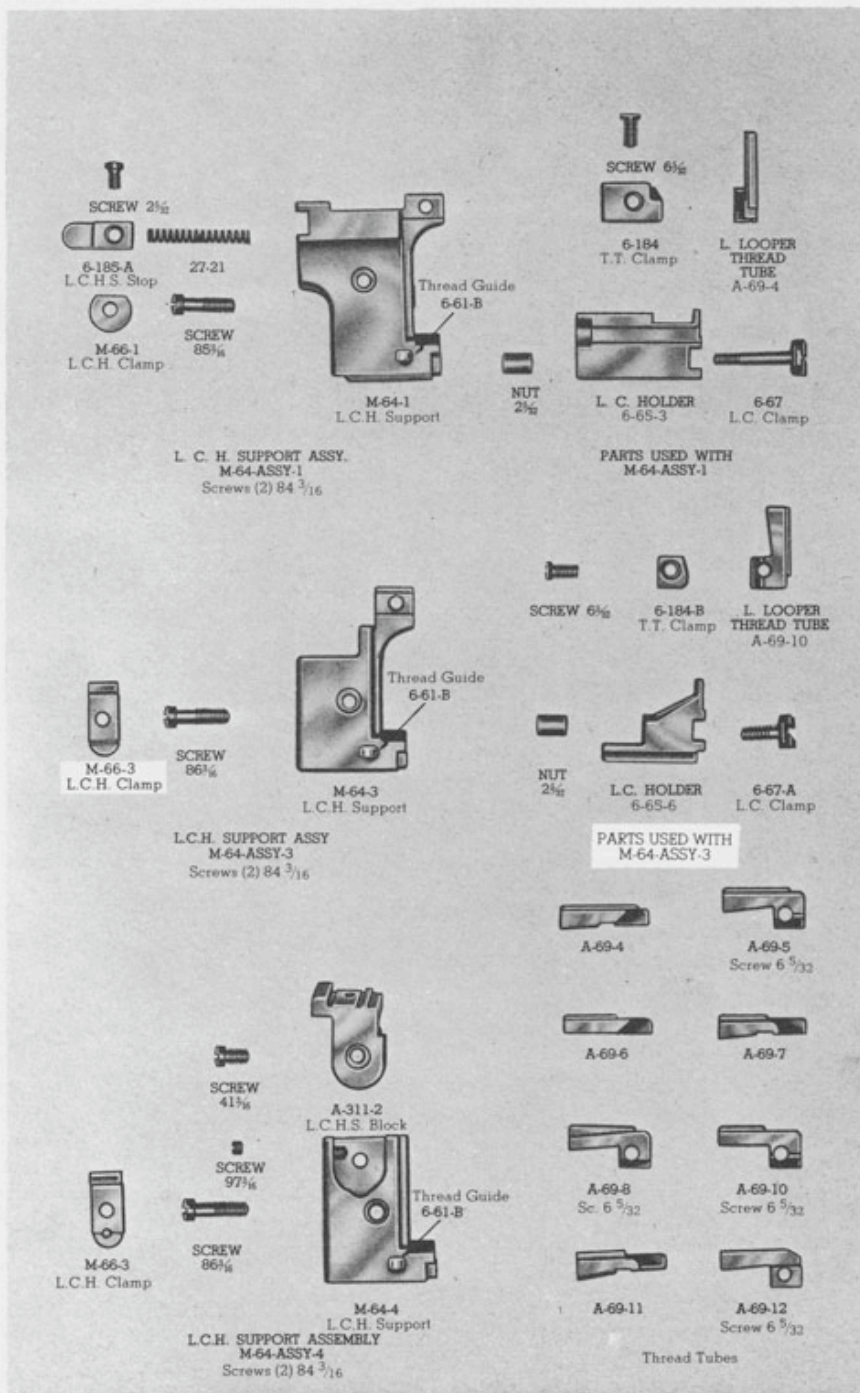

LOWER CUTTER HOLDER SUPPORT — THREAD TUBES

LOWER CUTTER HOLDER SUPPORT

Part No.	Type	Screws (2) 84 ³ / ₁₆					T. Guide	Style	Illust. Page
		L.C. Holder	L.C.H. Clamp	L.C. Clamp	L.L.T. Tube	T.T. Clamp			
M-64-Assy-1 Comp.	Spring	6-65-3	M-66-1	6-67	A-69-4	6-184	6-61-B	3DW, 3DW-2	8
M-64-Assy-2 Comp.	Rigid	6-65-U	M-66-3	6-67	A-69-5	6-184-B	6-61-B	3DW, 3DW-2	
M-64-Assy-3 Comp.	Rigid	6-65-6	M-66-3	6-67-A	A-69-10	6-184-B	6-61-B	2DH-1	8
M-64-Assy-4 Comp.	Rigid	6-65-4	M-66-3	6-67	A-69-12	None	6-61-B	3DW-3, 3DW-4	8
M-64-Assy-5 Comp.	Rigid	A-65-1	M-66-3	A-67-1	A-69-10	A-184-1	6-61-B	M-3DW-SI	

If *Assembly Only* is ordered, the following parts will *not* be included: L.C. Holder, L.C. Clamp, L.L.T. Tube, T.T. Clamp.

LOWER CUTTER HOLDER

A-65-1	Supplied in Support M-64-Assy-5	
6-65-U	Supplied in Support M-64-Assy-2	
6-65-3	Supplied in Support M-64-Assy-1	8
6-65-4	Supplied in Support M-64-Assy-4	
6-65-5	Supplied in Support M-64-Assy-1 for wide cutting	
6-65-6	Supplied in Support M-64-Assy-3	8
6-65-7	Supplied in Support M-64-Assy-1 for long feed stroke	

LOWER CUTTER HOLDER CLAMP

M-66-1	Supplied in Support M-64-Assy-1, Screw 85 ³ / ₁₆	8
M-66-3	Supplied in Support M-64-Assy-2,3,4,5, Screw 86 ³ / ₁₆	8

LOWER CUTTER CLAMP

Nut 2⁵/₃₂

A-67-1	Supplied in Support M-64-Assy-5	
6-67	Supplied in Support M-64-Assy-1, 2, 4	8
6-67-A	Supplied in Support M-64-Assy-3	8

LOWER LOOPER THREAD TUBE

Screw 6⁵/₃₂

Part No.	Used on Support Type	Feed Row(s)	Use T.T. Clamp	Comments	Illust. Page
A-69-5	Rigid M-64-Assy-2, 3	Double	6-184-B		8
A-69-6	Spring M-64-Assy-1	Hemming	6-184		8
A-69-7	Spring M-64-Assy-1	Single	6-184		8
A-69-8	Rigid M-64-Assy-2, 3	Single	6-184-B		8
A-69-10	Rigid M-64-Assy-2, 3	Hemming	6-184-B		8
A-69-11	Spring M-64-Assy-1	Single	6-184	Thread hole .020 lower than A-69-7	8
A-69-12	Rigid M-64-Assy-4	Double	None		8
A-69-14	Spring M-64-Assy-1	Double	6-184	Thread hole .040 lower than A-69-4	
A-69-16	Spring M-64-Assy-1	Single	6-184	Thread hole .030 lower than A-69-11	
A-69-17	Rigid M-64-Assy-4	Double	None	Thread hole .070 lower than A-69-12	
A-69-18	Spring M-64-Assy-10	Single	6-184	Used on Style 3DWL	

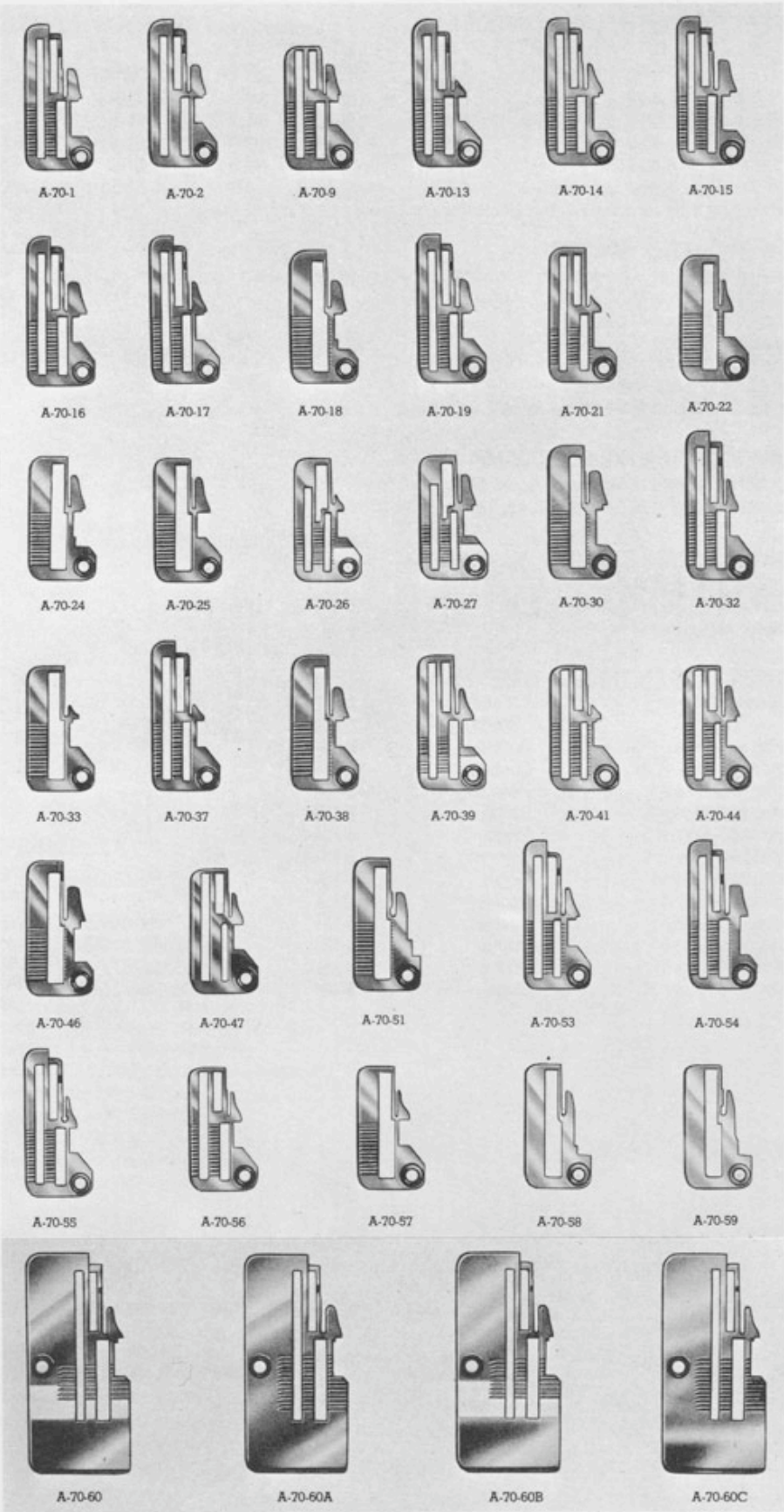

NEEDLE PLATE

NEEDLE PLATE							Illust.
Part No.	Opening for Cutter	Maximum Needle	Feed Row(s)	Approx. Stitch Width	Screw 7 ⁵ / ₃₂ Comments	Style	Page
A-70-1	Wide	5D	Double	5 ⁵ / ₃₂ "			10
A-70-2	Narrow	3D	Double	5 ⁵ / ₃₂ "			10
A-70-9	Narrow	3D	Double	5 ⁵ / ₃₂ "			10
A-70-13	Narrow	3D	Double	Stub			10
A-70-14	Wide	5D	Double	1 ¹ / ₈ "			10
A-70-15	Wide	5D	Double	3 ³ / ₁₆ "			10
A-70-16	Narrow	3D	Double	3 ³ / ₁₆ "			10
A-70-17	Narrow	3D	Double	1 ¹ / ₈ "			10
A-70-18	Wide	5D	Single	5 ⁵ / ₃₂ "			10
A-70-19	Narrow	5D	Double	5 ⁵ / ₃₂ "			10
A-70-21	Wide	5D	Double	Stub	Slope front	2DH-2	10
A-70-22	Narrow	3D	Single	7 ¹ / ₆₄ "			10
A-70-23	Wide	5D	Single	3 ³ / ₁₆ "			10
A-70-24	Wide	3D	Single	5 ⁵ / ₃₂ "			10
A-70-25	Narrow	3D	Single	5 ⁵ / ₃₂ "			10
A-70-26	Narrow	2D	See Picture	Stub	Slope front	2DH-1	10
A-70-27	Narrow	3D	See Picture	5 ⁵ / ₃₂ "	Chaining finger on Needle Plate	2DH-1	10
A-70-30	Wide	5D	Single	3 ³ / ₁₆ "			10
A-70-32	Narrow	3D	Double	3 ³ / ₃₂ "			10
A-70-33	Narrow	5D	Single	Stub			10
A-70-34	None	3D	Double	3 ³ / ₁₆ "	Used without cutters		
A-70-36	Narrow	3D	Single	Stub			
A-70-37	Narrow	3D	Double	Stub	Use with front feed A-81-19		10
A-70-38	Narrow	3D	Single	5 ⁵ / ₃₂ "			10
A-70-39	Wide	5D	Double	9 ⁹ / ₆₄ "	Chaining finger on Needle Plate	2DH-2	10
A-70-40	None	5D	Single	3 ³ / ₁₆ "	Used without cutters		
A-70-41	Narrow	3D	Double	Stub	Use with front feed A-81-19		10
A-70-44	Narrow	3D	Double	5 ⁵ / ₃₂ "	Use with front feed A-81-19		10
A-70-46	Wide	5D	Single	7 ⁷ / ₃₂ "			10
A-70-47	Narrow	3D	Double	3 ³ / ₃₂ "	Use with front feed A-81-19		10
A-70-51	Wide	8D	Single	5 ⁵ / ₃₂ "	Used with wide rolling finger 6-106-19	3DR	10
A-70-53	Narrow	3D	Double	1 ¹ / ₈ "	Use with front feed A-81-19		10
A-70-54	Wide	5D	Double	7 ⁷ / ₃₂ "			10
A-70-55	Similar to A-70-32 but has countersink in top of needle slot — Double Row Feed						10
A-70-56	Similar to A-70-32 but shorter						10
A-70-57	Narrow	2D	Single	1 ¹ / ₁₆ "			10
A-70-58	Wide	5D	Single	5 ⁵ / ₃₂ "	Used with usual rolling finger A-106-6	3DR	10
A-70-59	Similar to A-70-58 except for 8D Needle						10
A-70-60	Wide	5D	Double	1 ¹ / ₈ "	Slope front surface	3DW-3	10
A-70-60A	Wide	5D	Double	5 ⁵ / ₃₂ "	Front surface flat	3DW-3	10
A-70-60B	Wide	5D	Double	5 ⁵ / ₃₂ "	Slope front surface	3DW-3	10
A-70-60C	Similar to A-70-60 but front surface flat						3DW-3 10

From the library of: Diamond Needle Corp

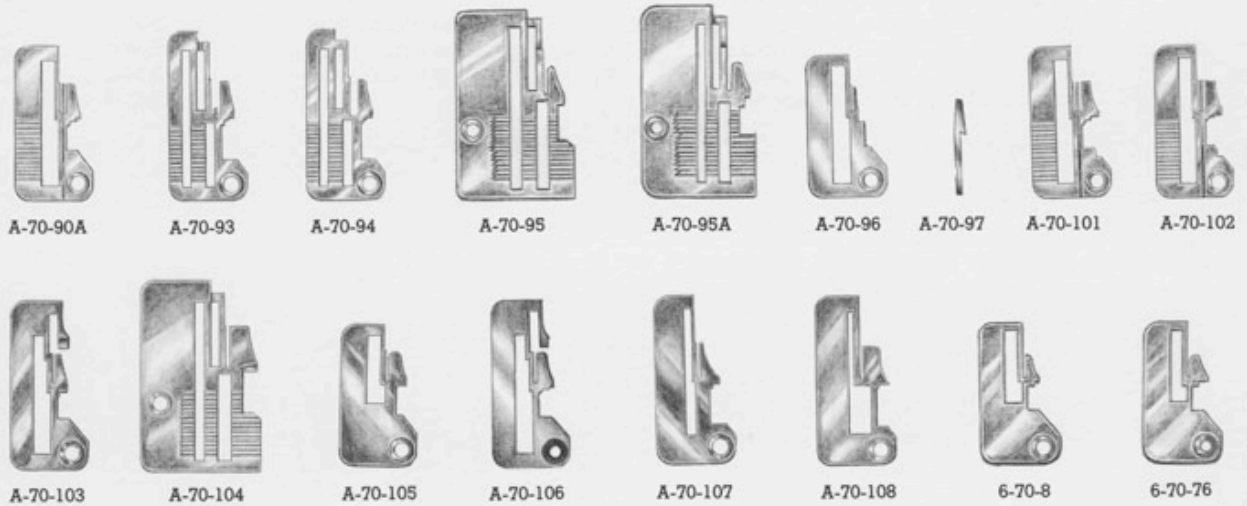
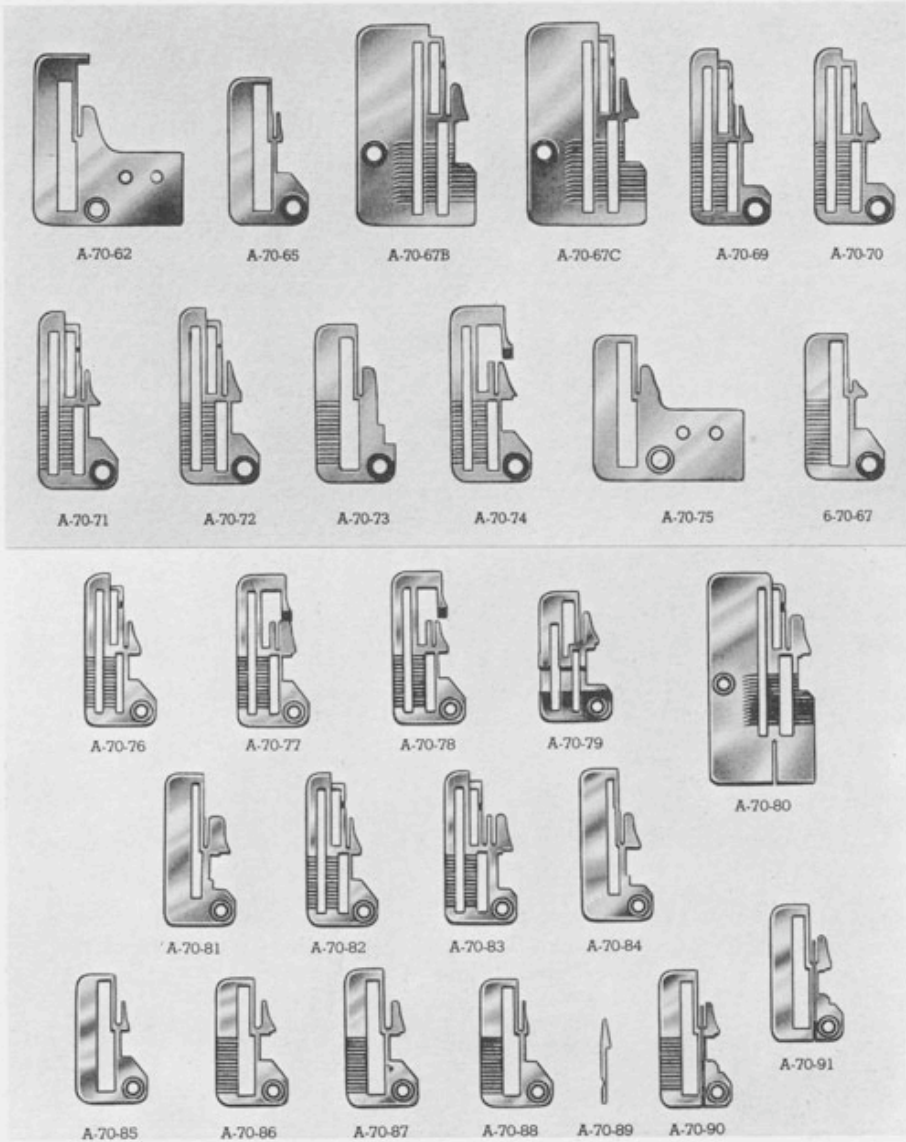

NEEDLE PLATE

Part No.	NEEDLE PLATE			Approx. Stitch Width	Screw 7 ⁵ / ₃₂	Comments	Style	Illust. Page
	Open for Cutter	Maximum Needle	Feed Row(s)					
A-70-62	None	5D	Single	$\frac{3}{16}$ "		Used without cutters		12
A-70-65	Narrow	2D	Single			Very narrow	2DNR-1	12
A-70-67B	Wide	5D	Double	$\frac{5}{32}$ "			3DW-4	12
A-70-67C	Wide	5D	Double	$\frac{1}{8}$ "			3DW-4	12
A-70-69	Wide	3D	Double	$\frac{7}{32}$ "				12
A-70-70	Wide	3D	Double	$\frac{1}{8}$ "				12
A-70-71	Narrow	3D	Double	$\frac{5}{64}$ "				12
A-70-72	Narrow	3D	Double	$\frac{1}{8}$ "				12
A-70-73	Wide	5D	Single	$\frac{5}{32}$ "		Like A-70-51 except for 5D Needle		12
A-70-74	Narrow	3D	Double	$\frac{1}{8}$ "				12
A-70-75	None	2D	Single	$\frac{7}{32}$ "		Used without cutters		12
A-70-76	Narrow	3D	Double	$\frac{3}{32}$ "		Use with front feed A-81-19		12
A-70-77	Narrow	3D	Double	$\frac{5}{32}$ "		Similar to A-70-74		12
A-70-78	Narrow	3D	Double	$\frac{3}{32}$ "		Similar to A-70-74		12
A-70-79	Wide	3D	Like A-70-27	$\frac{5}{32}$ "			M-3DW-SI	12
A-70-80	Wide	5D	Double	$\frac{7}{32}$ "		Similar to A-70-60A	3DW-3	12
A-70-81	Wide	3D	Single	$\frac{3}{16}$ "			M-3Q-3	12
A-70-82	Narrow	2D	Double	$\frac{1}{16}$ "		Similar to A-70-72		12
A-70-83	Wide	A.5D	Double	$\frac{1}{4}$ "			M-4DW-100	12
A-70-84	Wide	3D	Single	$\frac{1}{8}$ "			M-3Q	12
A-70-85	Narrow	B.1DE	Single	$\frac{3}{32}$ "			4D-45 Ladies'	12
A-70-86	Narrow	B.2SD	Single	$\frac{7}{64}$ "			4D-45 Men's	12
A-70-87	Narrow	B.2SD	Single	$\frac{1}{8}$ "		Similar to A-70-86	4D-45 Men's	12
A-70-88	Narrow	4D	Single	$\frac{1}{16}$ "		Used with 6-106-23	2DNR-1	12
A-70-89	Web used with Pin 36-58 in A-70-90 and A-70-91.							12
A-70-90	Narrow	B.1SD	Single	$\frac{1}{8}$ "		Use Web A-70-89	4D-45 Men's	12
A-70-90A	Narrow	B.1SD	Single	$\frac{1}{8}$ "		Similar to A-70-90 except Web A-70-97 is deeper and longer to draw off more needle thread	4D-45 Men's	12
A-70-91	Narrow	A.2D	Single	$\frac{1}{8}$ "		Use Web A-70-89	4D-60 Men's	12
A-70-93	Wide	A.3D	Double	$\frac{5}{32}$ "			4DW-60	12
A-70-94	Wide	A.5D	Double	$\frac{7}{32}$ "			4DW-60	12
A-70-95	Wide	5D	Double	$\frac{1}{8}$ "			3DW-4	12
A-70-95A	Wide	5D	Double	$\frac{5}{32}$ "			3DW-4	12
A-70-96	Narrow	2D	Single			Similar to A-70-65 except wider at cutters		12
A-70-97	Web similar to A-70-89 except deeper and longer, used in A-70-90A, 101, 102, Pin 36-58							12
A-70-101	Narrow	A.2D	Single	$\frac{5}{32}$ "		Similar to A-70-91 except wider chaining finger, Web A-90-97	4D-60 Men's	12
A-70-102	Narrow	B.1SD	Single	$\frac{5}{32}$ "		Similar to A-70-90 except wider chaining finger, Web A-90-97	4D-45 Men's	12
A-70-103	Narrow	3D	Single	$\frac{1}{8}$ "			3DWL	12
A-70-104	Wide	5D	Double	$\frac{1}{4}$ "			3DW-7	12
A-70-105	Narrow	5D	Single	$\frac{7}{16}$ "			3U	12
A-70-106	Narrow	3D	Single	$\frac{5}{32}$ "			3DWL	12
A-70-107	Wide	3D	Single	$\frac{1}{16}$ "			M-3Q	12
A-70-108	Wide	3D	Single	$\frac{3}{16}$ "			M-3Q-3	12
6-70-8	Narrow	5D	Single	$\frac{1}{8}$ "			3U	12
6-70-76	Narrow	5D	Single	$\frac{5}{32}$ "			3U	12

The width of stitch produced by various Needle Plates is only approximate and will vary depending on the length of stitch, width of cutting, and the type of material being sewn.

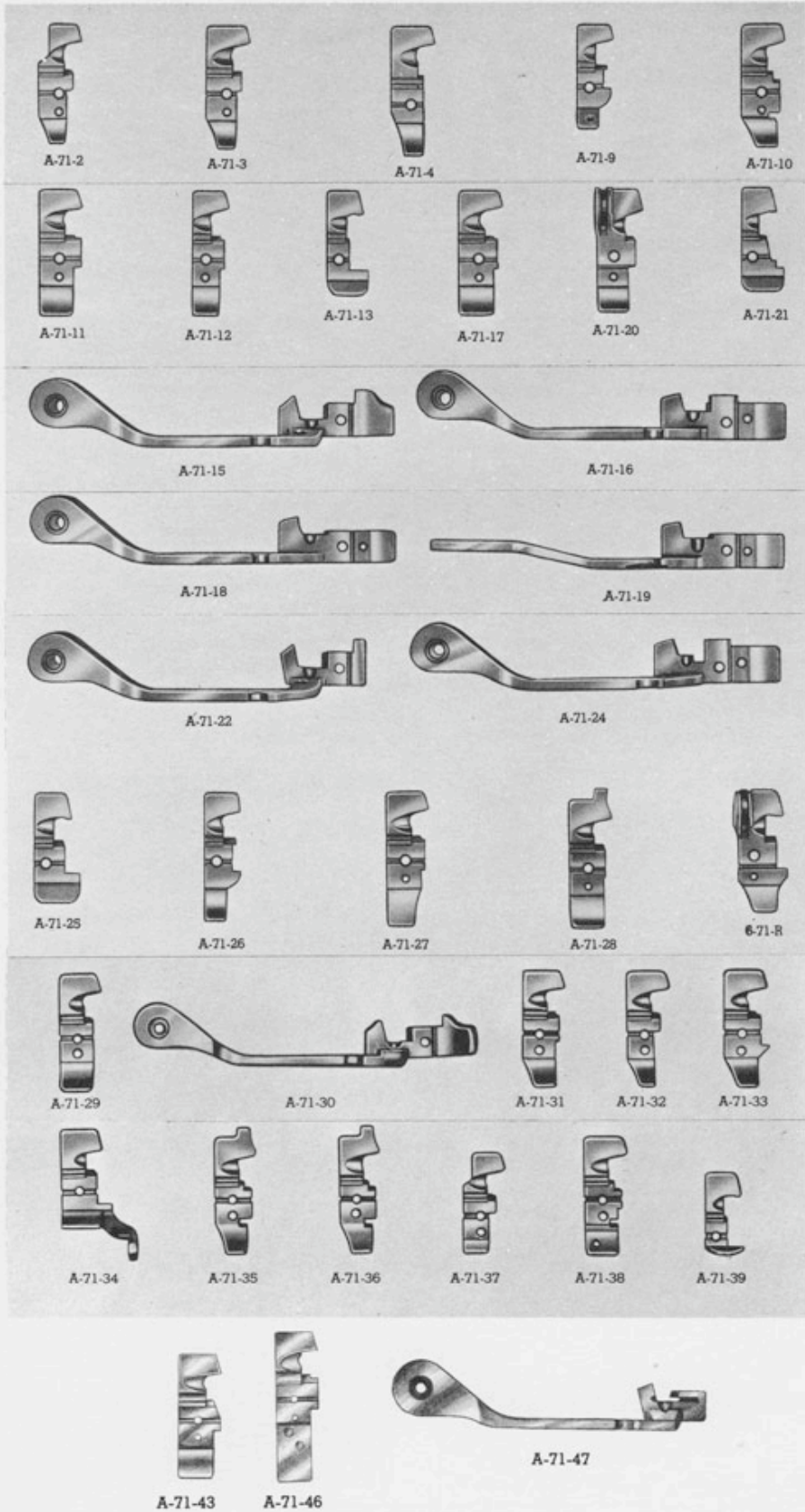

PRESSER FOOT

From the library of: Diamond Needle Corp



6-71-71



6-71-78



6-71-80



6-71-84



6-71-92



6-71-93

PRESSER FOOT

Part No.	Special Use	*Feed Cutters	P.F. Arm	Complete with following Parts	Illust. Page
A-71-2	Hemming	DN	A-206-5	A-106-5, 6-125-B, Sc. 9 ¹ / ₈ , 6-114-A, Sc. 12 ³ / ₃₂	14
A-71-3	Hemming	DN	A-206-5	A-106-5, 6-125-B, Sc. 9 ¹ / ₈ , 6-114-A, Sc. 12 ³ / ₃₂	14
A-71-4	Hemming	DN	A-206-7	A-106-7, 6-125-B, Sc. 9 ¹ / ₈ , A-103-6	14
A-71-9		SN	A-206-6	A-106-35, A-125-1, Sc. 9 ¹ / ₈	14
A-71-10	Taping	DN	A-206-5	A-106-12, 6-125-B, Sc. 9 ¹ / ₈ , A-114-2, Sc. 3 ³ / ₃₂	14
A-71-11	Similar to A-71-17 but wider by cutters.				14
A-71-12		SN	A-206-6	A-106-25, A-125-1, Sc. 9 ¹ / ₈ , A-114-3, Sc. 12 ³ / ₃₂	14
		SW	A-206-6	A-106-25, A-125-1, Sc. 9 ¹ / ₈ , A-114-5, Sc. 12 ³ / ₃₂	
		SN	A-206-6	A-106-15, A-125-1, Sc. 9 ¹ / ₈	14
A-71-13	Rigid	SN	None	6-106-H, Sc. 3 ¹ / ₈	14
A-71-15	Rigid	DN	None	6-106-K, Sc. 3 ¹ / ₈ , A-114-3, Sc. 12 ³ / ₃₂	14
A-71-16	Rigid	DW	None	6-106-K, Sc. 3 ¹ / ₈ , A-114-5, Sc. 12 ³ / ₃₂	14
A-71-17		DN	A-206-5	A-106-25, 6-125-B, Sc. 9 ¹ / ₈ , A-114-3, Sc. 12 ³ / ₃₂	14
		DW	A-206-5	A-106-25, 6-125-B, Sc. 9 ¹ / ₈ , A-114-5, Sc. 12 ³ / ₃₂	
A-71-18	Hemming	DN	None	6-106-C, Sc. 3 ¹ / ₈ , 6-114-A, Sc. 12 ³ / ₃₂	14
A-71-20	Hemming	DN	A-206-4	6-106-C, 6-125, Sc. 3 ¹ / ₈ , A-114-3, Sc. 12 ³ / ₃₂	14
A-71-21	Rolling	SN	A-206-6	6-106-23, A-125-1, Sc. 9 ¹ / ₈	14
A-71-22	Rigid	SN	None	6-106-H, Sc. 3 ¹ / ₈	14
A-71-24	Taping 1/4"	DW	None	A-106-19, Sc. 3 ¹ / ₈ , A-114-5, Sc. 12 ³ / ₃₂	14
A-71-25		SN	A-206-6	A-106-25, A-125-1, Sc. 9 ¹ / ₈	14
A-71-26	Hemming	SN	A-206-6	A-106-8, A-125-1, Sc. 9 ¹ / ₈	14
A-71-27		DN	A-206-5	A-106-25, 6-125-B, Sc. 9 ¹ / ₈ , A-114-6, Sc. 12 ³ / ₃₂	14
		DW	A-206-5	A-106-25, 6-125-B, Sc. 9 ¹ / ₈ , A-114-7, Sc. 12 ³ / ₃₂	
A-71-28		DN	A-206-8	A-106-25, 6-125-B, Sc. 9 ¹ / ₈ , A-114-3, Sc. 12 ³ / ₃₂	14
		DW	A-206-8	A-106-25, 6-125-B, Sc. 9 ¹ / ₈ , A-114-5, Sc. 12 ³ / ₃₂	
A-71-29	Similar to A-71-17 but narrower by cutters				14
A-71-30	Similar to A-71-15 but for wide cutters				14
A-71-31	Similar to A-71-17 but front left like 6-71-93				14
A-71-32	Similar to A-71-3 but narrower by cutters				14
A-71-33	Similar to 6-71-93 but for wide cutters using A-114-1				14
A-71-34	M-3DW-SI (Shirring)	DW	A-206-8	A-106-24, 6-125-B, Sc. 9 ¹ / ₈ , Blade Assy. A-Assy-9 or A-Assy-12, Sc. 6 ⁵ / ₃₂ , Washer 1 ⁵ / ₃₂ , Nut 1 ⁵ / ₃₂	14
A-71-35	Similar to A-71-10 but heel like A-71-28				14
A-71-36	Similar to A-71-35 but heel flat on bottom				14
A-71-37	Similar o A-71-2 but toe shorter for Hemming Assy. #4B				14
A-71-38	Taping 1/8" to 7/16"	DN	A-206-5	A-106-25, 6-125-B, Sc. 9 ¹ / ₈ , A-114-2, Sc. 3 ³ / ₃₂ , A-211-3, A-211-3A, Sc. 2 ³ / ₃₂	14
A-71-39	Similar to A-71-13 but toe shorter				14
A-71-40	Similar to A-71-18 except alteration to Presser Bar locating surface used with P. Arm Assembly, A-Assy-15 to laterally adjust Presser Foot				
A-71-43	Similar to A-71-11, except angular cut added to P.F. Finger surface to clear material when used with P.F. Finger A-106-37				14
A-71-46	Similar to A-71-11 but with toe extension to prevent material from catching on toe of Presser Foot				14
A-71-47	Rigid	SN	None	Used on 3U Emblem machine	14
6-71-78	Rolling	SN	A-206-6	A-106-6, A-125-1, Sc. 9 ¹ / ₈	15
6-71-80		DN	A-206-5	6-106-10, 6-125-B, Sc. 9 ¹ / ₈	15
6-71-84	Rolling	SDW	A-206-5	6-106-19, 6-125-B, Sc. 9 ¹ / ₈	15
6-71-92		DW	A-206-7	6-106-10, 6-125-B, Sc. 9 ¹ / ₈	15
6-71-93		DN	A-206-5	A-106-25, 6-125-B, Sc. 9 ¹ / ₈ , 6-114-D, Sc. 12 ³ / ₃₂	15

*Feed - Single Row "S", Double Row "D"
 *Cutter - Narrow "N", Wide "W"

Feed Mechanism

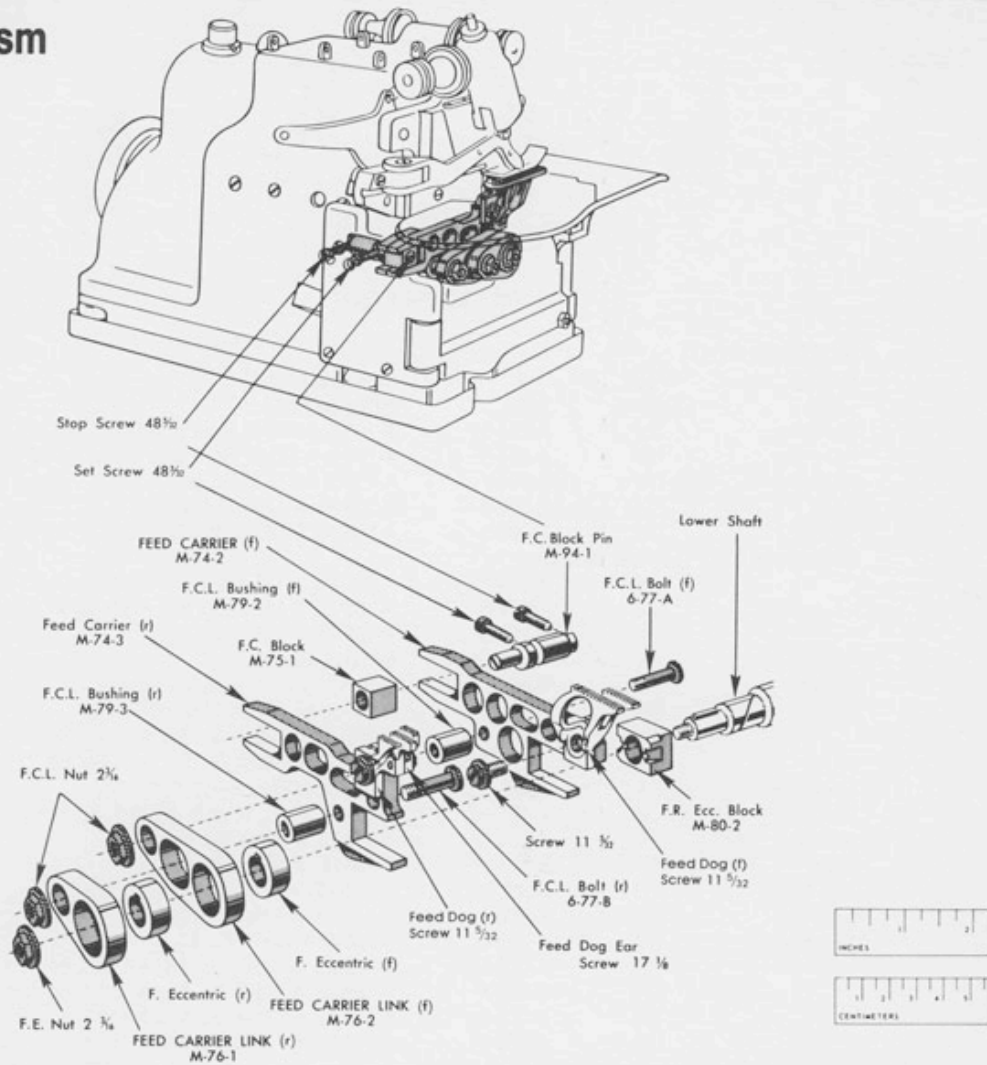

Part No.	Description	Illust. Page
M-74-1	FEED CARRIER For Non-differential Feed	16
M-74-2	For Differential Feed (Front)	16
M-74-3	For Differential Feed (Rear)	16
M-74-4	For Differential Feed (Front), on Style M-3DW-SI	
M-74-6	For Differential Feed (Rear) used on hemming machine with Stabilizing Block M-359-1	
M-75-1	FEED CARRIER BLOCK Used with F.C.B.E. Pin M-94-1	16
M-75-2	Used with F.C.B.E. Pin M-94-2 on Style M-3DW-SI	
M-76-1	FEED CARRIER LINK For Non-differential Feed or Short Link for Differential Feed	16
M-76-2	Long Link for Differential Feed	16
6-77-A	FEED CARRIER LINK BOLT Used with Feed Carriers M-74-1, 2, 4; ⁵⁵ / ₆₄ " long	16
6-77-B	Used with Feed Carrier M-74-3; ⁵⁹ / ₆₄ " long	16
M-79-1	FEED CARRIER LINK BUSHING Used with Feed Carrier M-74-1; .257" long	
M-79-2	Used with Feed Carrier (Front) M-74-2, 4; .474" long	16
M-79-3	Used with Feed Carrier (Rear) M-74-3; .529" long	16
M-79-4	Used in place of M-79-2 on Style M-3DW-SI	
M-79-5	Used in place of M-79-3 on Style M-3DW-SI	
M-80-2	FEED RAISING ECCENTRIC BLOCK Generally used	16
M-80-3	Hole offset to set F. Carriers low, used on Style MG-3DW-7	
6-80-B	Used on Style M-3DW-SI (two per machine)	

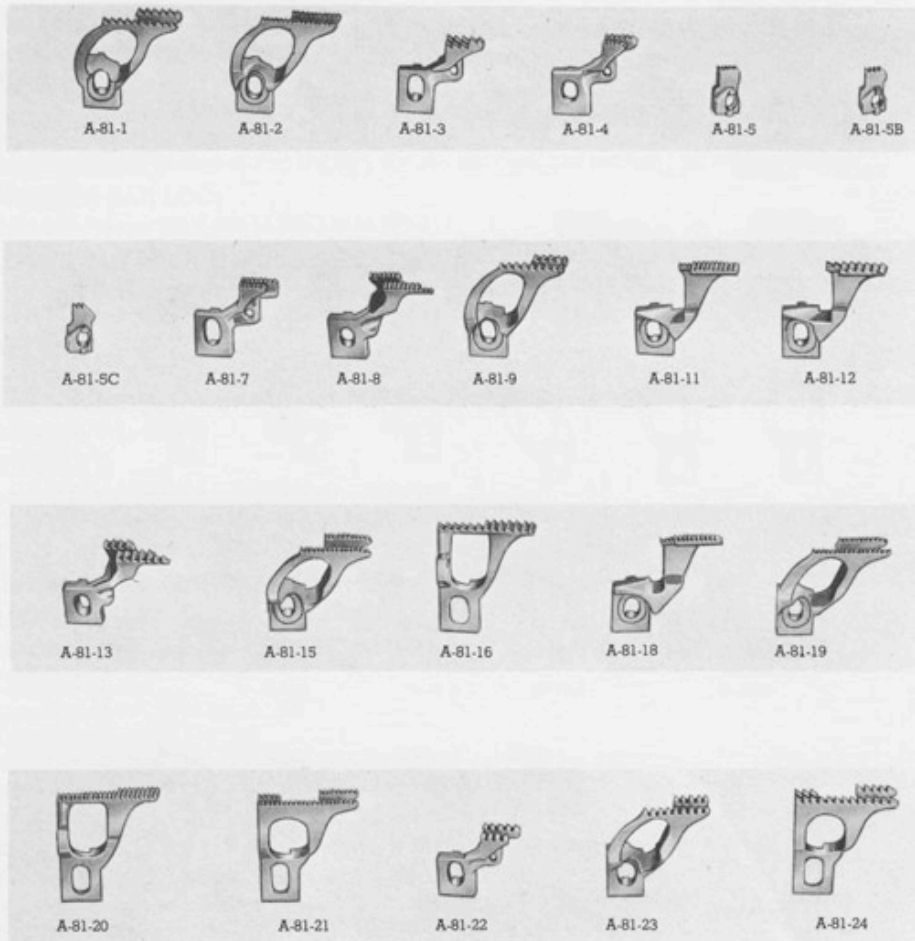

FEED DOG

Part No.	FEED DOG	Screw 11 ³ / ₃₂ Differential Feed Dog		Style	Illust. Page
		Screw 16 ⁷ / ₁₆ Non-Differential Feed Dog			
A-81-1	Front differential, double row, coarse teeth				17
A-81-2	Front differential, double row, fine teeth				17
A-81-3	Rear differential, double row, coarse teeth, used with Feed Ear A-81-5C				17
A-81-4	Rear differential, double row, fine teeth, used with Feed Ear A-81-5C				17
A-81-5	Feed Dog Ear, five fine teeth, Sc. 8 ⁷ / ₁₆				17
A-81-5B	Feed Dog Ear, similar to A-81-5 but four fine teeth, Sc. 8 ⁷ / ₁₆				17
A-81-5C	Feed Dog Ear, similar to A-81-5 but three fine teeth, Sc. 8 ⁷ / ₁₆				17
A-81-7	Rear differential, double row, fine teeth, used with Feed Ear A-81-5C				17
A-81-8	Rear differential, single row, fine teeth with integral ear, ear has seven teeth				17
A-81-8B	Similar to A-81-8 but has six teeth				
A-81-8C	Similar to A-81-8 but has five teeth				
A-81-8D	Similar to A-81-8 but has four teeth				
A-81-9	Front differential, double row, coarse teeth, one tooth less on each row than A-81-1				17
A-81-11	Front differential, single row, fine teeth				17
A-81-12	Front differential, single row, coarse teeth				17
A-81-13	Rear differential, single row, coarse teeth with integral ear, ear has four teeth				17
A-81-13B	Similar to A-81-13 but has three teeth				
A-81-13C	Similar to A-81-13 but has two teeth				
A-81-15	Front differential, double row, fine teeth front teeth on angle			2DH-1	17
A-81-16	Non-differential, single row, coarse teeth, use with Feed Ear 6-81-X				17
A-81-18	Front differential, single row, fine teeth, front angled				17
A-81-19	Front differential, double row, fine teeth, same as A-81-2, except right feed is narrow, used with Needle Plate A-70-37			2DH	17
A-81-20	Non-differential, single row, fine teeth, use with Feed Ear 6-81-X				17
A-81-21	Non-differential, double row, fine teeth, use with Feed Ear 6-81-X				17
A-81-22	Rear differential, double row, coarse deep teeth, use with Feed Ear A-81-5C				17
A-81-23	Front differential, double row, similar to A-81-9 but with coarse deep teeth				17
A-81-24	Non-differential, double row, coarse teeth, use with Feed Ear 6-81-X				17

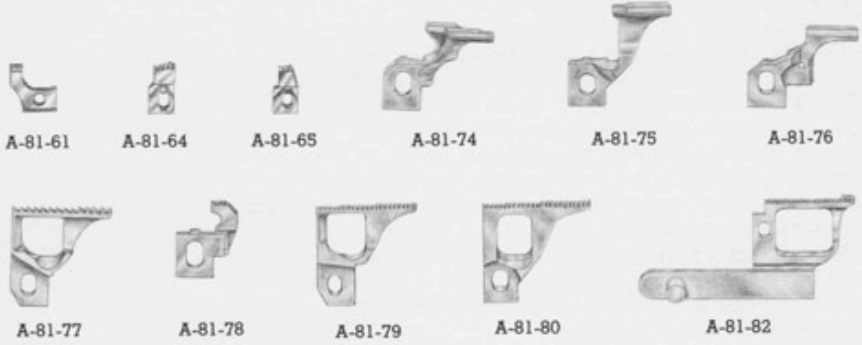

FEED DOG

Part No.	FEED DOG	Screw 11 ⁵ / ₃₂ Differential Feed Dog	Style	Illust. Page
		Screw 16 ³ / ₁₆ Non-Differential Feed Dog		
A-81-25	Feed Dog Ear, six fine teeth, narrow, Sc. 8 ¹ / ₈			18
A-81-25B	Feed Dog Ear, four coarse teeth, narrow, Sc. 8 ¹ / ₈			18
A-81-27	Rear differential, single row, coarse teeth similar to A-81-13 but one tooth less on feed row and on ear			18
A-81-28	Front differential, double row, coarse teeth		3DW-3	18
A-81-30	Front differential, double row, fine teeth. Discontinued — Use A-81-56			18
A-81-31	Front differential, double row, deep coarse teeth		3DW-3	
A-81-34	Non-differential, double row, fine teeth			18
A-81-35	Front differential, double row, fine teeth. Discontinued — Use A-81-59			18
A-81-36	Front differential, double row, coarse teeth		3DW-4	18
A-81-37	Feed Dog Ear, five fine teeth, left side flush with attached			18
	Feed Dog, for use with Needle Plate A-70-74, Sc. 8 ¹ / ₈			
A-81-37B	Feed Dog Ear, similar to A-81-37 but four fine teeth, Sc. 8 ¹ / ₈			18
A-81-38	Non-differential, single row, fine teeth			18
A-81-39	Non-differential, single row, coarse teeth		3U	18
A-81-40	Front differential, double row, fine teeth		3DW-SI	18
A-81-41	Rear differential, single row, coarse teeth, used with A-81-5C		3DW-SI	18
A-81-42C	Feed Dog Ear, three fine teeth			
A-81-43	Rear differential, single row, fine teeth, used with A-81-5C			18
A-81-44	Similar to A-81-43 but coarse teeth			18
A-81-45	Non-differential, single row, fine teeth		M-3Q	18
A-81-46	Similar to A-81-1 but front teeth angled like A-81-15		2DH-2	18
A-81-47	Similar to A-81-40 but more feeding surface			18
A-81-48	Non-differential, single row, fine teeth		M-3Q-3	18
A-81-49	Feed Dog Ear, three fine teeth, left side flush with attached			18
	Feed Dog, extra wide feeding surface, Sc. 17 ¹ / ₈			
A-81-50	Feed Dog Ear, used with A-81-51, 53, etc., five fine teeth, Sc. 17 ¹ / ₈			18
A-81-50B	Similar to A-81-50, but four fine teeth, Sc. 17 ¹ / ₈			18
A-81-50C	Similar to A-81-50, but three fine teeth, Sc. 17 ¹ / ₈			18
A-81-51	Similar to A-81-3, but Ear A-81-50C is adjustable without removing from machine			18
A-81-53	Similar to A-81-7, but adjustable ear like A-81-51			18
A-81-54	Similar to A-81-22, but adjustable ear like A-81-51		3DW-4	18
A-81-55	Similar to A-81-28, but additional teeth on rear of long feed surface			18
A-81-56	Similar to A-81-30, but additional feeding like A-81-55			18
A-81-57	Similar to A-81-31, but additional feeding like A-81-55			18
A-81-58	Similar to A-81-36, but additional feeding like A-81-55			18
A-81-59	Similar to A-81-35, but additional feeding like A-81-55			18
A-81-60	Feed Dog Ear, similar to A-81-37, but for use with A-81-53, five fine teeth, Sc. 17 ¹ / ₈			18
A-81-60B	Feed Dog Ear, similar to A-81-60, but four fine teeth, Sc. 17 ¹ / ₈			18
A-81-61	Feed Dog Ear, similar to 6-81-X, except thinner and longer, three teeth, Sc. 1 ¹ / ₈			18
A-81-64	Feed Dog Ear, similar to A-81-5 but additional feeding right hand side, five teeth, Sc. 8 ¹ / ₈			18
A-81-65	Feed Dog Ear, similar to A-81-5C but additional feeding right hand side, three teeth, Sc. 8 ¹ / ₈			18
A-81-74	Similar to A-81-8, except smooth polyurethane feeding surface			18
A-81-75	Similar to A-81-11, except smooth polyurethane feeding surface			18
A-81-76	Similar to A-81-43, except smooth polyurethane feeding surface			18
A-81-77	Front differential, single row, coarse teeth		3DU	18
A-81-78	Rear differential, fine teeth, single row, used with front Feed A-81-79 and Needle Plate A-70-106		3DWL	18
A-81-79	Front differential, fine teeth, single row, used with rear Feed, A-81-78 and L.L. Thread Tube A-69-7, 8 or 11		3DW	18
A-81-80	Front differential, fine teeth, single row, used with L.L. Thread Tube A-69-18 and Needle Plate A-70-103		3DWL	18
A-81-82	Non-differential, single row, fine teeth		M-3Q-3	18
6-81-X	Feed Dog Ear, three teeth, Sc. 1 ¹ / ₈			18
6-81-12	Feed Dog Ear, four teeth, Sc. 1 ¹ / ₈			18

From the library of: Diamond Needle Corp

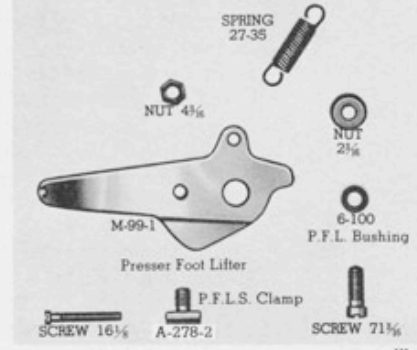
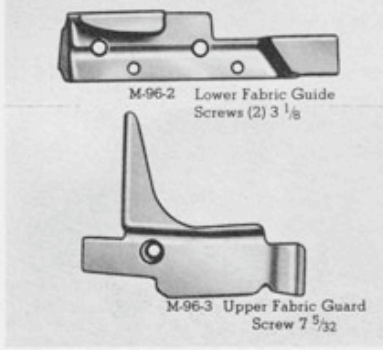
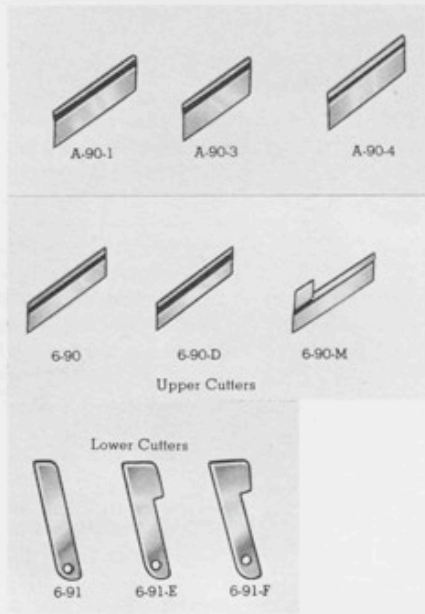
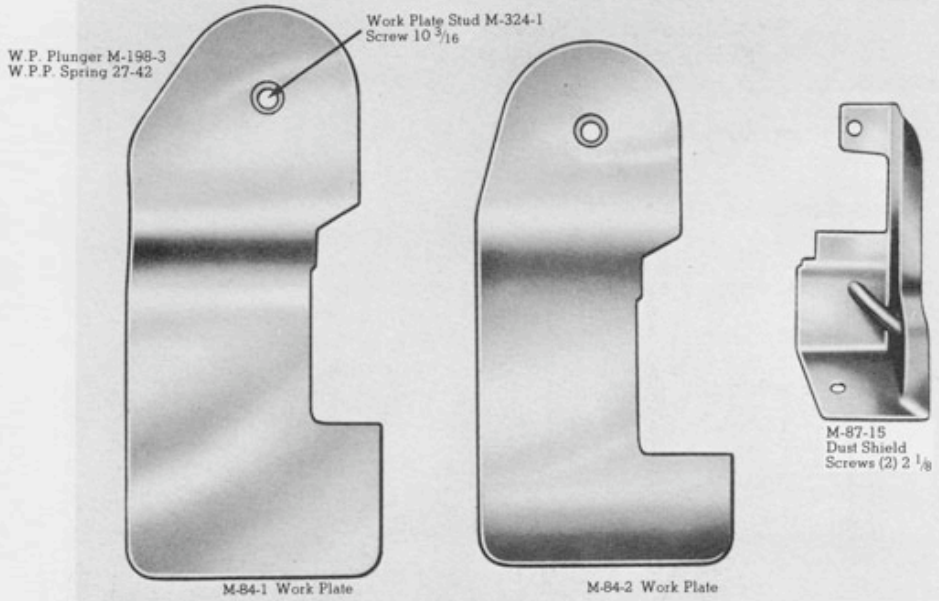

Part No.
6-82

FEED ECCENTRIC

Feed Eccentrics, Key-On (Stitches to the Inch) 3, 3 1/2, 4, 4 1/2, 5, 6, 7, 8, 9, 10, 12, 14, 16, 18, 20, 22, 24, 26, 28, 30, 32, 34, 36, 40, 50, 60, 70, 80, 90, 100

Illust.
Page
16

WORK PLATE

Work Plate Stud M-324-1
Screw 10 3/16

- M-84-1 Straight front
- M-84-2 Curved front, small — used on Styles similar to M-84-1
- M-84-3 Curved front, small
- M-84-4 Straight front
- M-84-5 Straight front for submerged table mountings
- M-84-6 Straight front
- M-84-7 Straight front (Needle Plate A-70-67)
- M-84-8 Curved front with rib
- M-84-11 Straight front, used with straight front Needle Plate
- M-84-12 Curved front, used with sloped front Needle Plate
- M-84-13 Straight front
- M-84-14 Work Plate Cover; covers only above Work Plate Support
- M-84-15 Curved front with rib, left hand side relieved for small tubular work
- M-84-16 Curved front, small
- M-84-17 Curved front, small used on Styles similar to M-84-5
- M-84-18 Similar to M-84-11, but curved front
- M-84-23 Similar to M-84-16, except for 1/16" less offset

Style

- 3DW, 3DW-2 2,20
- 3DW, 3DW-2 20
- 3DR, 3DRW, 4D-45 Men's and Ladies' 20
- 2DNR-1, 3U
- 3DW-2
- 2DH-1
- 3DW-4
- 2DH-1
- 3DW-3
- 3DW-3
- M-3DW-SI
- 2DH-1
- 3DW-4
- 3DW-7

DUST SHIELD

Screws (2) 2 1/8

- M-87-2 Similar to M-87-3, except for narrow or stub chaining finger
- M-87-3 Similar to M-87-2, except no Thread Tube
- M-87-4 Similar to M-87-3, except no Thread Tube
- M-87-5 Similar to M-87-6, except clearance by Needle Plate
- M-87-6 Similar to M-87-3, except spacer soldered to help stabilize Dust Shield
- M-87-7
- M-87-12

Style

- M-3DW-2, 3, 4 20
- M-3DW
- M-4D-45 Men's 3DR

Part No.			Style	Illust. Page
M-87-13	DUST SHIELD	Screws (2) 2¹/₈		
M-87-15	Similar to M-87-3, except thread conductor is extra hard		3DR	
M-87-16	Similar to M-87-2, except clearance for Cutter Holder A-56-4 and Upper Cutter		MG-3DW-2, 3, 4	2,20
	Similar to M-87-6, no Thread Tube		MG-2DH-1, MG-2DNR-1	
M-89-2	HEAD CAP			2,20
A-89-6	Used with H.C. Extension M-327-1, Screw 36 ⁵ / ₃₂ , Screw 53 ⁵ / ₃₂			
6-89-G	Used with P.B. Catch A-270-1 to Lock-up Presser Foot, Screws (2) 36 ⁵ / ₃₂			
	Used with Large Wheel Presser Foot, Screws (4) 5 ³ / ₁₆			
A-90-1	UPPER CUTTER			20
A-90-2	Serrated, wide			
A-90-3	Same as A-90-1, but not serrated			
A-90-4	Similar to A-90-1, but shorter, serrated			20
A-90-5	Similar to A-90-1, but same width as 6-90, serrated			20
A-90-6	Similar to A-90-4, but not serrated			
A-90-7	Similar to A-90-3, but not serrated			
A-90-8	Similar to A-90-3, but projection added on front, serrated			
6-90	Similar to A-90-3, but carbide			
6-90-C	Narrow width			20
6-90-D	Like 6-90 but narrower			
6-90-E	Wide, same width as A-90-1			20
6-90-F	Similar to 6-90, but shorter			
6-90-G	Similar to 6-90-D, but shorter			
6-90-H	Similar to 6-90, but serrated			
6-90-I	Similar to 6-90-D, but serrated			
6-90-J	Similar to 6-90-H, but shorter, serrated			
6-90-K	Similar to 6-90-C, but shorter			
6-90-L	Similar to 6-90-G, but shorter, serrated			
6-90-M	Similar to 6-90, but projection on front added			20
6-90-P	Similar to 6-90-D, but projection added on front			
6-90-Q	Similar to 6-90-D, but carbide			
6-90-R	Similar to 6-90-F, but carbide			
6-90-S	Similar to 6-90-C, but carbide			
6-91	LOWER CUTTER			20
6-91-C	Narrow width, used with Upper Cutter 6-90			
6-91-E	Used with Upper Cutter 6-90-C			
6-91-F	Wide width, used with A-90-1, thickness .041			20
6-91-G	Extra wide Lower Cutter; used with special U.C. Holder EXC-302-4 or EXC-302-4A.			20
6-91-H	Similar to 6-91-F, but thicker .062			
6-91-I	Similar to 6-91-G, except width of 6-91-E, thickness .062			
6-91-J	Similar to 6-91-G, except thickness .055 and no rib			
6-91-K	Similar to 6-91-H, except thickness .055 and no rib			
6-91-L	Similar to 6-91-E, but carbide			
6-91-M	Similar to 6-91, but carbide			
6-91-N	Similar to 6-91-H, but carbide			
M-94-1	FEED CARRIER BLOCK ECCENTRIC PIN	Screws (2) 48⁵/₃₂		16
M-94-2	Generally used			
M-94-3	Used with M-75-2 on Style M-3DW-SI			
M-94-6	Hole plug for Style M-3DW-SI			
	Used to lower Feed Carriers when using F.R.E. Block M-80-3			
M-96-2	FABRIC GUARD			20,36
M-96-3	Fabric Guard (Lower) Screws (2) 3 ¹ / ₈			
M-96-4	Fabric Guard (Upper) Screw 7 ⁵ / ₃₂			20,36
	Similar to M-96-3, except for Extra Wide Needle Plates, Screw 7 ⁵ / ₃₂			
A-97-1	UPPER CUTTER HOLDER CLAMP	Screw 8¹/₈		5
	Generally used			
M-99-1	PRESSER FOOT LIFTER			20,36
	Generally used			
	P.F.L. Bushing 6-100, Sc. 71 ³ / ₁₆ , Nut 2 ³ / ₁₆			20,36
	P.F.L. Stop Clamp A-278-2, Sc. 16 ¹ / ₈ , Nut 4 ³ / ₁₆			20,36
	Spring 27-35			20,36
	Presser Foot Lifter Treadle Complete 10-3			
	Presser Foot Lifter Treadle Spring 27-18			
	Presser Foot Lifter Treadle Chain 6-195			
6-99-C	Used with Head M-2-6 and Head Cap 6-89-G on Large Wheel Foot Machine			
6-100	PRESSER FOOT LIFTER BUSHING			20,36
	Presser Foot Lifter Nut 2 ³ / ₁₆			
	Presser Foot Lifter Screw 71 ³ / ₁₆			

From the library of: Diamond Needle Corp

Pin 36-9

Hem Fold Guide Hinge 6-130-C

Hem Fold Guide 6-104 Specify Width

Screw 7 1/2

Hem Edge Guide 6-103-A

Hem Guide Holder 6-102

Hem Guide Support 6-101

Screw 16 1/2

Hem Fold Guide Hinge Block 6-131-A

Screw 8 1/2

Hem Guide Holder Clamp 6-105

Screw 2 1/2

Screw 32 1/2

Hem Guide Support 6-101

Screw 16 1/2

HEMMING ASSEMBLY #3

Pin 36-9

Hem Fold Guide Hinge 6-130-D

Hem Fold Guide 6-104 Specify Width Hem Fold Guide

Screw 6 1/4

6-288 Spring

Screw 34 3/8

6-229 Bushing

Hem Edge Guide 6-103-U

Hem Guide Holder 6-102-E

Hem Guide Support 6-101

Screw 16 1/2

Hem Fold Guide Hinge Block 6-131-C

Screw 8 1/2

Waasher 1 1/2

6-288 Spring

6-198-C Spring

27-32

Hem Guide Holder Clamp 6-105

Screw 2 1/2

Hem Guide Support 6-101

Screw 32 1/2

HEMMING ASSEMBLY #4

Hem Fold Guide A-104-3 Specify Width

Screw 14 1/2

Washer 1 1/2

Screw 27 1/2

Hem Fold Guide Pivot A-301-1 or 2

Screw 38 1/2

H F Guide Pivot Block A-131-1

Screw 78 3/4

Screw 34 1/2

6-229 Bushing

Hem Edge Guide A-103-5

Fabric Guide A-107-2

Hem Edge Guide Cover A-302-1

Screw 4 1/2

Hem Guide Support 6-101

Screw 16 1/2

Hem Guide Holder A-102-2

6-198-C Spring

27-25

Hem Guide Holder Clamp 6-105

Screw 2 1/2

Screw 32 1/2

HEMMING ASSEMBLY #7 Hinged Pivot

Hem Edge Guide 6-103-C

Hem Guide Plate 6-120

Hem Guide Holder 6-102-A

Hem Guide Support 6-101

Screw 16 1/2

Screw 7 1/2

Hem Guide Holder Clamp 6-105-A

Screw 2 1/2

Screw 32 1/2

HEMMING ASSEMBLY #8 WELTING ATTACHMENT

HEMMING ASSEMBLY #3

For use on Style M or MG-2DH
 Hem Guide Support 6-101
 Screw 16⁵/₃₂
 Hem Guide Holder 6-102
 Adjusting Screw 32³/₁₆
 Hem Edge Guide 6-103-A
 Screw 7⁵/₃₂
 Hem Guide Holder Clamp 6-105
 Screw 2⁵/₃₂
 Hem Fold Guide, specify hem width
 Screw 5¹/₈
 Hem Fold Guide Hinge 6-130-C
 Pin 36-9
 Hem Fold Guide Hinge Block 6-131-A
 Screw 8⁵/₃₂

HEMMING ASSEMBLY #4

For use on Style M or MG-2DH-1
 Hem Guide Support 6-101
 Screw 16⁵/₃₂
 Hem Guide Holder 6-102-E
 Adjusting Screw 32³/₁₆
 Spring 27-25
 Plunger 6-198-C
 Adjusting Screw 27³/₁₆
 Lock Screw 27³/₁₆
 Hem Edge Guide 6-103-U
 Bushing 6-229
 Pivot Screw 34⁵/₃₂
 Hem Fold Guide 6-104, specify hem width
 Screw 6¹/₈
 Hem Guide Holder Clamp 6-105
 Screw 2⁵/₃₂
 Hem Fold Guide Hinge 6-130-D
 Spring 6-268
 Hem Fold Guide Hinge Block 6-131-C
 Pin 36-9
 Spring 27-32
 Screw 8⁵/₃₂
 Adjusting Screw 29⁵/₃₂
 Washer 1⁵/₃₂

WELTING ATTACHMENT

Hem Guide Support 6-101
 Screw 16⁵/₃₂
 Hem Guide Holder 6-102-A
 Adjusting Screw 32³/₁₆
 Hem Edge Guide 6-103-C
 Screw 7⁵/₃₂
 Hem Guide Holder Clamp 6-105-A
 Screw 2⁵/₃₂
 Hem Guide Plate 6-120

HEMMING ASSEMBLY #4B

For use on Style M or MG-2DH-1
 Hem Guide Support 6-101
 Screw 16⁵/₃₂
 Hem Guide Holder A-102-2
 Adjusting Screw 32³/₁₆
 Spring 27-25
 Plunger 6-198-C
 Adjusting Screw 27³/₁₆
 Lock Screw 27³/₁₆
 Hem Edge Guide A-103-5
 Bushing 6-229
 Pivot Screw 34⁵/₃₂
 Hem Fold Guide 6-104 or EXB-803, specify hem width
 Screw 6¹/₈

HEMMING ASSEMBLY #7 (Hinged Pivot)

For use on Style M or MG-2DH-1
 Hem Guide Support 6-101
 Screw 16⁵/₃₂
 Hem Guide Holder A-102-2
 Adjusting Screw 32³/₁₆
 Hem Edge Guide A-103-5
 Plunger 6-198-C
 Bushing 6-229
 Pivot Screw 34⁵/₃₂
 Spring 27-25
 Adjusting Screw 27³/₁₆
 Lock Screw 27³/₁₆
 Hem Guide Holder Clamp 6-105
 Screw 2⁵/₃₂
 Hem Fold Guide A-104-3, specify hem width
 Screw 14¹/₈
 Washer 1¹/₈
 Hem Fold Guide Pivot A-301-1 (use A-301-2 with A-104-3, over 1")
 Clamping Screw 78⁷/₁₆
 Hem Edge Guide Cover A-302-1
 Hem Fold Guide Pivot Block A-131-1
 Screw 38⁵/₃₂
 Adjusting Screw 27³/₁₆ (2)
 Fabric Guide A-107-2
 Screw 4¹/₈

Hem Guide Holder Clamp 6-105
 Screw 2⁵/₃₂
 Hem Fold Guide Hinge 6-130-D
 Spring 6-268
 Hem Fold Guide Hinge Block 6-131-C
 Pin 36-9
 Spring 27-32
 Screw 8⁵/₃₂
 Adjusting Screw 29⁵/₃₂
 Washer 1⁵/₃₂
 Fabric Guide A-107-4
 Screw 4¹/₈
 Hem Edge Guide Cover A-302-1

Part No.

HEM GUIDE SUPPORT

6-101 Hem Guide Support Screw 16⁵/₃₂
 Hem Guide Holder Adjusting Screw 32³/₁₆

HEM GUIDE HOLDER

A-102-2 Used with Hemming Assembly #4B and #7 22
 6-102 Used with Hemming Assembly #3 22
 6-102-A Used with Welting Attachment 22
 6-102-E Used with Hemming Assembly #4 22

HEM EDGE GUIDE

A-103-4 Guide for use on Presser Foot A-71-3, use with Uncurling Block 6-114-C, Screw 5⁵/₃₂ 25
 A-103-5 Used with Hemming Assembly #4B and #7, Screw 34⁵/₃₂ 22
 A-103-6 Guide for use on Presser Foot A-71-4, use with Presser Foot Finger A-106-7, Screw 9¹/₈ 25
 6-103-A Used with Hemming Assembly #3, Screw 7⁵/₃₂ 22
 6-103-C Used with Welting Attachment, Screw 7⁵/₃₂ 22
 6-103-U Used with Hemming Assembly #4, Screw 34⁵/₃₂ 22

**Illust.
Page**

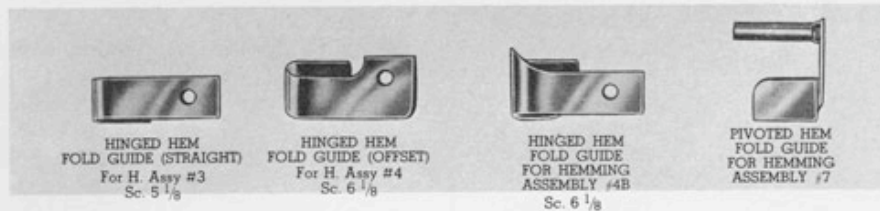

Part No.

HEM FOLD GUIDE

Hinged Hem Fold Guide for Hemming Assemblies #3, #4, #4B, BA #3

Hem Size	<u>Straight #3</u>	<u>Offset #4</u>	<u>Offset #4B</u>	<u>BA #3</u>
3/8"	6-104-3	EXC-104-1	EXB-803-2E	
1/2"	6-104-T	6-104-25	6-104-50	6-104-38
5/8"	6-104-23	6-104-26	6-104-49	
3/4"	6-104-Q	6-104-30	6-104-48	6-104-39
7/8"	6-104-46	6-104-27	EXB-803-2C	
1"	6-104-R	6-104-28	EXB-803-2B	6-104-34
1 1/8"	6-104-L	6-104-32	EXB-803-2L	
1 1/4"	6-104-Y	6-104-37	EXB-803-2	6-104-40
1 3/8"			EXB-803-2H	
1 1/2"	6-104-P	6-104-36	EXB-803-2J	6-104-35
1 3/4"	6-104-Z		EXB-803-2P	6-104-41
1 7/8"			EXB-803-2G	
2"	6-104-V	6-104-33	EXB-803-2F	6-104-42
2 1/2"	6-104-M		EXB-803-2M	
3"	6-104-O			
3 1/2"	6-104-24			
4"	6-104-N			
4 1/2"	6-104-31			
5"	6-104-4			

7/32" Standard Opening for All H.F. Guides unless otherwise specified — 15/32" Standard for all BA #3 H.F. Guides

NOTES:

- For hemming medium weight material, the straight Hem Fold Guides mentioned above may be supplied with 9/32" opening when specified. When using the 9/32" Open Style, the Hem Fold Guide Hinge Block 6-131-B is required.
- For hemming heavy materials, certain Hem Fold Guides are available with 15/32" opening when specified. When using the 15/32" Open Style, the Hem Fold Guide Hinge Block 6-131-A and Shim EXB 873-19 are required on Hemming Assembly #3.
- Hinged Hem Fold Guide Screw 5 1/8 with 6-130-C. Hinged Hem Fold Guide Screw 6 1/8 with 6-130-D.

Pivoted Hem Fold Guide used on Hemming Assembly #7

1/4"-A-104-3	1/2"-A-104-3	3/4"-A-104-3	1"-A-104-3
3/8"-A-104-3	5/8"-A-104-3	7/8"-A-104-3	

Use Hem Fold Guide Pivot A-301-1 with above

1 1/4"-A-104-3	1 3/4"-A-104-3
1 1/2"-A-104-3	2" -A-104-3

Use Hem Fold Guide Pivot A-301-2 with above

Washer 1 1/8 Screw 14 1/8

HEM GUIDE HOLDER CLAMP

Screw 2 5/32

6-105	Used with Hemming Assemblies #3, #4, #4B, or #7	22
6-105-A	Used with Welting Attachment	22

PRESSER FOOT FINGER

Screw 9 1/8

A-106-2	Stub finger 5/32" wide, used with center hinged Presser Foot for single or double row feed	25
A-106-3	Chaining finger 3/32" wide, used on center hinged Presser Foot for single or double row feed	25
A-106-5	Chaining finger 7/64" wide, used on center hinged Presser Foot for single or double row feed, (used on Hemming Machines)	25
A-106-6	Stub finger adapted to make rolled edge finish 5/32" wide, use with 6-71-78 on Style 3DR, no Key	25
A-106-7	Stub finger 5/32" wide, used with center hinged Presser Foot A-71-4 for double row feed and Hem Edge Guide A-103-6	25
A-106-8	Stub finger 7/64" wide, used with center hinged Presser Foot A-71-26	25
A-106-10	Chaining finger 1/8" wide, otherwise similar to A-106-5	25
A-106-11	Stub finger 5/32" wide for inserting cord within stitch, otherwise similar to A-106-2	25
A-106-12	Stub finger, adapted to insert 1/8" wide woven or elastic tape under edge finish, tape not pierced by needle, used with Presser Foot A-71-10	25
A-106-13	Chaining Finger 3/32" wide	25
A-106-14	Stub finger to make rolled edge finish on light material	25



Part No.

PRESSER FOOT FINGER

A-106-15	Chaining finger to make rolled edge finish on lightweight material used with Presser Foot A-71-13, no Key	25
A-106-17	Stub finger $\frac{1}{4}$ " wide, used with Presser Foot 6-71-92, no Key	25
A-106-18	Chaining finger, $\frac{1}{8}$ " wide, used on rigid Presser Foot, Screw $3\frac{1}{8}$	
A-106-19	Stub finger, adapted to insert $\frac{1}{4}$ " wide woven or elastic tape under edge finish, tape pierced by needle, used with Presser Foot A-71-24, Screw $3\frac{1}{8}$	25
A-106-20	Chaining finger, $\frac{1}{8}$ " wide, similar to A-106-10 but finger is longer	25
A-106-21	Stub finger, similar to A-106-2 but $\frac{1}{16}$ " wider	25
A-106-22	Stub finger, similar to A-106-12 but adapted to run $\frac{3}{16}$ " wide tape	25
A-106-23	Stub finger, adapted to insert $\frac{1}{8}$ " wide, woven or elastic tape, pierced by needle, used with rigid Presser Foot, Screw $3\frac{1}{8}$	25
A-106-24	Stub finger, similar to A-106-25, but narrower	25
A-106-25	Similar to A-106-2, but angled to clear upper looper	25
A-106-26	Similar to A-106-2, except groove added for inserting cord within stitch and piercing cord	25
A-106-27	Similar to A-106-21, except for narrower trimming	25
A-106-28	Similar to A-106-13, except finger stubbed	25
A-106-29	Chaining finger, $\frac{5}{32}$ " wide, used with rigid Presser Foot, Screw $3\frac{1}{8}$	25
A-106-30	Similar to A-106-27, except grooved for Style 4DW-100 or 107	25
A-106-31	Similar to A-106-24, except for narrower trimming	25
A-106-32	Similar to A-106-27, except altered to Style 4DW-60	25
A-106-33	Similar to A-106-28, except altered for 4D-45	25
A-106-34	DISCONTINUED Use A-106-37	
A-106-35	Similar to A-106-33, except wide extension to right for uncurling fabric on Style 4D-45, Men's and Ladies' Hosiery	25
A-106-37	Compressing finger compresses fabric within stitch formation replaces A-106-34	25
6-106-B	Stub finger $\frac{3}{32}$ " wide, used with rigid Presser Foot for double row feed, Screw $3\frac{1}{8}$	25
6-106-C	Chaining finger $\frac{3}{32}$ " wide, used with rigid Presser Feet for double row feed, Screw $3\frac{1}{8}$	25
6-106-H	Stub finger $\frac{5}{32}$ " wide, used with rigid Presser Feet for single row feed, Screw $3\frac{1}{8}$	25
6-106-K	Stub finger $\frac{5}{32}$ " wide, used on rigid Presser Feet for double row feed, Screw $3\frac{1}{8}$	25
6-106-8	Stub finger $\frac{5}{32}$ " wide, used with center hinged Presser Foot 6-71-92 on machine with 6-90-D Upper Cutter	25
6-106-10	Similar to 6-106-8 but wider by Upper Cutter	25
6-106-17	Stub finger, adapted to make rolled edge finish used with Presser Foot 6-71-78	25
6-106-19	Stub finger, adapted to make rolled edge finish on heavy material, used with Presser Foot 6-71-84, no Key	25
6-106-23	Similar to A-106-6 but considerably narrower, used on Style 2DNR-1	25

FABRIC GUIDE

A-107-1	Used with Presser Foot A-71-9, Screw $2\frac{3}{32}$	25
A-107-2	Used with Hemming Assembly #7, Screw $4\frac{1}{8}$	22
A-107-3	Used with Presser Foot A-71-21, Screw $8\frac{1}{8}$	25
A-107-4	Similar to A-107-2 except left side removed, used with Hemming Assembly #4B, Screw $4\frac{1}{8}$	
A-107-5	Attaches to Presser Arm to prevent chain and material from curling back into stitch, Screws (2) $11\frac{3}{32}$	
6-107	Edge Guide adapted to be used in place of Lower Cutter	25
6-107-B	Edge Guide adapted to be used in place of Lower Cutter	25
6-107-25	Edge Guide adapted to be used in place of Lower cutter — Style 3U Emblem	

Illust. Page

From the library of: Diamond Needle Corp

Needle Carrier Assembly

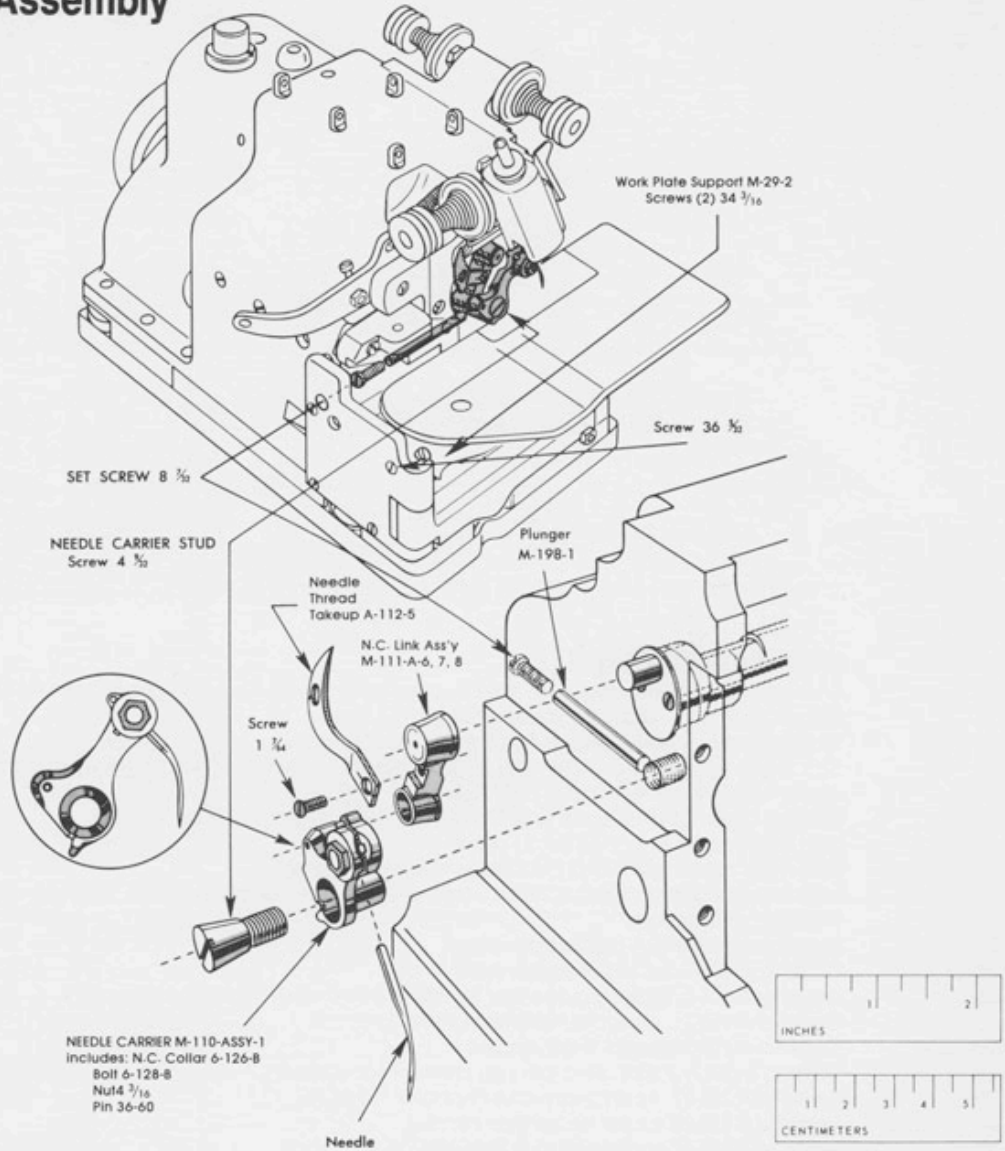

Needle
Thread
Take-ups
Screw 1 7/64

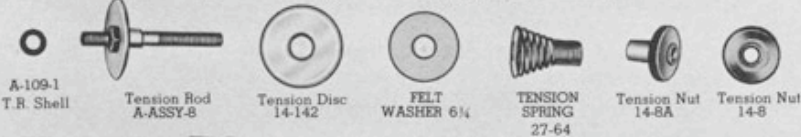
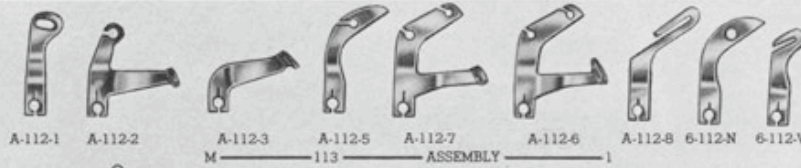

P.F.
Uncurling Blocks

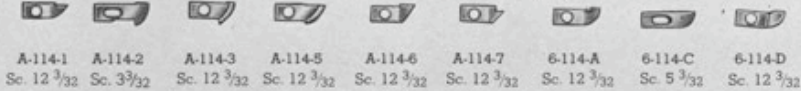

Part No.	TENSION ROD SHELL	Illust. Page					
A-109-1		26					
	NEEDLE CARRIER						
	Needle						
	Carrier						
	Collar						
	Bolt						
	Pin						
	Spacer						
	Nut						
M-110-Assy-1	M-110-1	6-126-B	6-128-B	36-60	None	4 ³ / ₁₆	26
M-110-Assy-5	M-110-5	6-126-B	6-128-B	36-60	None	4 ³ / ₁₆	
M-110-Assy-45	M-110-45	M-126-1	M-128-1	36-60	None	4 ³ / ₁₆	
M-110-Assy-60	M-110-60	M-126-1	M-128-1	36-60	None	4 ³ / ₁₆	
M-110-Assy-100	M-110-100	M-126-1	M-128-2	36-60	M-250-1	4 ³ / ₁₆	
M-110-Assy-101	M-110-101	M-126-3	M-128-2	36-60	M-250-1	4 ³ / ₁₆	
	NEEDLE CARRIER LINK					Style	
M-111-Assy-6	Used with Upper Shaft M-62-Assy-8, 14,18					3DW-2, 3, 4	26
M-111-Assy-7	Used with Upper Shaft M-62-Assy-5, 15B					2DH-1, 2DNR-1	26
M-111-Assy-8	Similar to M-111-Assy-6, except .020 shorter — used with Upper Shaft M-62-Assy-16					3DW-7	26
	NEEDLE THREAD TAKEUP			Screw 1⁷/₆₄		Style	
A-112-1	For two thread or three thread box stitch, used with Thread Guides 6-61-E and 6-61-N					2DH-1, 3DR	26
A-112-2	For tight needle thread, used with Thread Guide A-61-4					3DW-2, 2DNR-1, 3U	26
A-112-3	For tight needle thread, used with Thread Guide A-61-4						26
A-112-5	For tight needle thread, used with Thread Guide 6-61-H, slot added for threading					3DW-2 or 4 Knit	26
A-112-6	Used with Thread Guides A-61-4, 6 and 8					4DW-100	26
A-112-7	Used with Thread Guides A-61-4, 6 and 8					4DW-60	26
A-112-8	Used with Thread Guides M-61-7, 8					4D-45 Ladies'	26
6-112-N	Similar to A-112-5, except not slotted						26
6-112-V						4D-45 Men's	26
	TENSION ROD						
M-113-Assy-2	Consists of: T.Rod A-113-1, (2) T.Disc 14-142, Felt Washer 6 ³ / ₄ , T. Nut (Holds Spring) 14-8A, T. Nut 14-8, T.R. Shell A-109-1, and Tension Spring (14-760, 14-64 or 14-64A) Specify Spring desired						4,36
A-113-1	Tension Rod only						
A-Assy-8	A-113-1 assembled with Tension Disc 14-142 (soldered)						26
	PRESSER FOOT UNCURLING BLOCK						
A-114-1	For wide Upper Cutter, Screw 12 ³ / ₃₂						26
A-114-2	Used with Presser Foot A-71-10, for narrow Upper Cutter, Screw 3 ³ / ₃₂						26
A-114-3	For narrow Upper Cutter, Screw 12 ³ / ₃₂						26
A-114-5	Generally used for wide Upper Cutter, Screw 12 ³ / ₃₂						26
A-114-6	Used with Presser Foot A-71-27 for narrow cutters, Screw 12 ³ / ₃₂						26
A-114-7	Used with Presser Foot A-71-27 for wide cutters, Screw 12 ³ / ₃₂						26
A-114-8	Similar to A-114-2, except for wide Upper Cutter, Screw 3 ³ / ₃₂						26
6-114-A	Generally used on Presser Foot aranged for hemming or welting, narrow cutters, Screw 12 ³ / ₃₂						26
6-114-C	Used with Presser Foot for hemming and narrow cutters, Screw 5 ³ / ₃₂						26
6-114-D	Used with Presser Foot 6-71-93 for narrow cutters, Screw 12 ³ / ₃₂						26
	SWING EDGE GUIDE BUSHING						
6-117							3
	SWING EDGE GUIDE SUPPORT			Screw 50³/₁₆ (Short)			
M-119-1	Used with S.E. Guide 6-8					Screw 93³/₁₆ (Long)	3
	THREAD CUTTER				Screws (2) 11³/₃₂		
A-121-1	Use with Presser Arm A-206-5, A-206-6, or A-206-7						26
A-121-2	Similar to A-121-1, except sets ¹ / ₁₆ " higher on Presser Arm						26
A-121-3	Similar to A-121-1, except cutting slot further back on Presser Arm						26
	PRESSER FOOT HINGE SPRING			Screw 9³/₈			
A-125-1	For center hinged Presser Foot, single row feed						26
6-125-B	For center hinged Presser Foot, double row feed						26

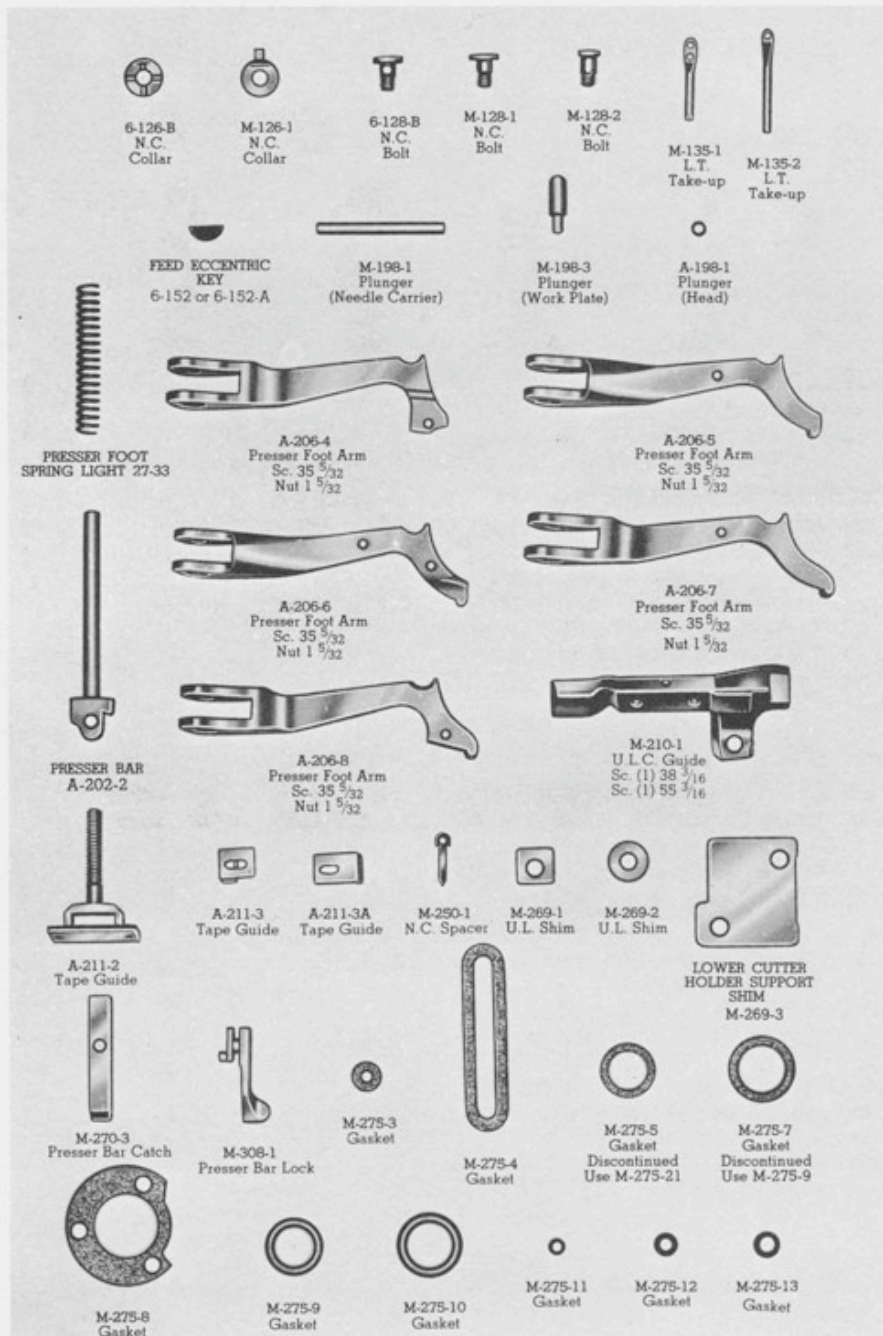

From the library of: Diamond Needle Corp

Part No.

6-126-B
M-126-1
M-126-2
M-126-3

A-126-1

6-128-B
M-128-1
M-128-2

M-135-1
M-135-2
M-135-6

NEEDLE CARRIER COLLAR

Generally used, supplied in M-110-Assy-1
Supplied in M-110-Assy-45, M-110-Assy-60, M-110-Assy-100. Has two thread eyes.
Similar to M-126-1, but slot is used in place of two thread eyes
Supplied in M-110-Assy-101, to offset point of left hand Needle .010 from point of right hand Needle.
Has two thread eyes
Similar to 6-126-B but has thread eye

NEEDLE CARRIER BOLT

Generally used; supplied in M-110-Assy-1, M-110-Assy-5
Supplied in M-110-Assy-45 and M-110-Assy-60
Supplied in M-110-Assy-100, M-110-Assy-101

LOOPER THREAD TAKEUP

Assembled in U.L.C. Slide M-332-Assy-1 and M-322-Assy-3
Assembled in L.L. Carrier M-51-Assy-1
Like M-135-2 except .020 shorter — Used in L.L. Carrier M-51-A-3

**Illust.
Page**

28
28

28
28
28

4,28
4,28
4

Part No.		Illust. Page
OIL COLLECTOR		
M-137-1	Discontinued — Use M-137-6	
M-137-2	Fits in Upper Shaft Hole in Frame with top marked "up." Spring 37-41	32
M-137-6	Replaces M-137-1, similar except has projection which serves as oil guard reducing oil throw, Screws (3) 15 ¹ / ₈	4
FEED ECCENTRIC KEY		
6-152	Used with Lower Shafts M-63-2 and M-63-Assy-12, 12A (Differential Feed)	28
6-152-A	Used with Lower Shafts M-63-1 and M-63-Assy-11, 11A (Differential Feed)	28
6-152-B	Used with Lower Shaft M-63-4 (Non-differential Feed)	
6-152-C	Used with Lower Shaft M-63-3 (Non-differential Feed)	
THREAD TUBE CLAMP		
	Screw 6⁵/₃₂	
M-184-1	Used with Thread Guide A-61-4, Spacer EXC-345-57, Screw 93 ⁷ / ₁₆	
A-184-1	Similar to 6-184-B, except relieved for front Feed Dog, used on Style M-3DW-SI	
6-184	Used on spring type Lower Cutter Holder Support, M-64-Assy-1	8
6-184-B	Used on rigid type Lower Cutter Holder Supports, M-64-Assy-2, 3	8
LOWER CUTTER HOLDER SPRING STOP		
	Screw 2⁵/₃₂	
6-185-A	Used with spring type Lower Cutter Holder Support M-64-Assy-1	8
PLUNGER		
M-198-1	Used in Frame to set Needle Carrier Stud Screw 4 ⁹ / ₃₂ , Set Screw 8 ⁷ / ₃₂	26,28
M-198-2	Oil Pump Plunger (2 per machine) Used with: Screw (Upper Pump) 8 ⁷ / ₁₆ or Screw (Lower Pump) 9 ⁷ / ₁₆ , Spring 27-40, Screw Gasket M-275-21	32,36
M-198-3	Work Plate Plunger — used with W.P.P. Spring 27-42	28
A-198-1	Used in Head with Screw 13 ⁵ / ₃₂	2,28
PRESSER BAR		
A-202-1	Used on Styles 2DH-1, 2DNR-1	2
A-202-2	Used on Style 3DW-2, 3DW-4	28
A-202-6	Similar to A-202-2, except end portion ¹ / ₁₆ " longer, used on Style 3DW-7	
PRESSER FOOT ARM		
	Screw 35⁵/₃₂	
	Nut 1⁵/₃₂	
A-206-5	Generally used for double row feed, center hinged Presser Foot	28
A-206-6	Generally used for single row feed, center hinged Presser Foot	28
A-206-7	Used with Presser Foot A-71-4, 6-71-92	28
A-206-8	Used with Wedge A-312-1, otherwise similar to A-206-5	28
UPPER LOOPER CARRIER GUIDE		
M-210-1	Screw 38 ⁷ / ₁₆ on outside of Frame Cap Screw 55 ⁷ / ₁₆ on inside of Frame Cap	4,28
TAPE GUIDE		
A-211-2	Used with Tension Plate A-317-1 to guide tape up to ¹ / ₂ " wide, used in A-Assy-10	28,34
A-211-3	Left hand Tape Guide for Presser Foot A-71-38, Screw 2 ⁷ / ₃₂	28
A-211-3A	Right hand Tape Guide for Presser Foot A-71-38, Screw 2 ⁷ / ₃₂	28
TAPE GUIDE HOLDER		
	Screws (2) 1¹/₈	
A-241-1	Used in A-Assy-10 with Tension Plate A-317-1	34
NEEDLE CARRIER SPACER		
M-250-1	Supplied in N. Carrier Assembly M-110-Assy-100 and M-110-Assy-101	28
SHIM		
M-269-1	For Upper Looper Carrier Guide M-210-1, square, specify thickness desired .0525, .0530, .0535,0570. Class M	4,28
M-269-2	For Upper Looper Carrier Guide, M-210-1, round, specify thickness desired .0510, .0515, .0520,0570. Class M	4,28
M-269-3	(.063 thickness) Used under Lower Cutter Holder Support	
M-269-4	(.103 thickness) Used under Lower Cutter Holder Support	
M-269-5	(.123 thickness) Used under Lower Cutter Holder Support	
M-269-6	(.140 thickness) Used under Lower Cutter Holder Support	
M-269-7	(.163 thickness) Used under Lower Cutter Holder Support	
M-269-8	(.183 thickness) Used under Lower Cutter Holder Support	
M-269-9	(.200 thickness) Used under Lower Cutter Holder Support	
M-269-10	(.093 thickness) Used under Lower Cutter Holder Support	
M-269-15	For Upper Looper Carrier Guide M-210-1, square, specify thickness desired, .0531, .0533, .0535,0555. Class MG	4
PRESSER BAR CATCH		
M-270-3	Generally used	2,28
M-270-4	Used on Styles that use Shim M-269-8 or M-269-9. Used with Presser Bar Lock M-308-1	
A-270-1	Used with Head Cap A-89-6 to lock-up Presser Foot	

Cleaning of Oil Filter

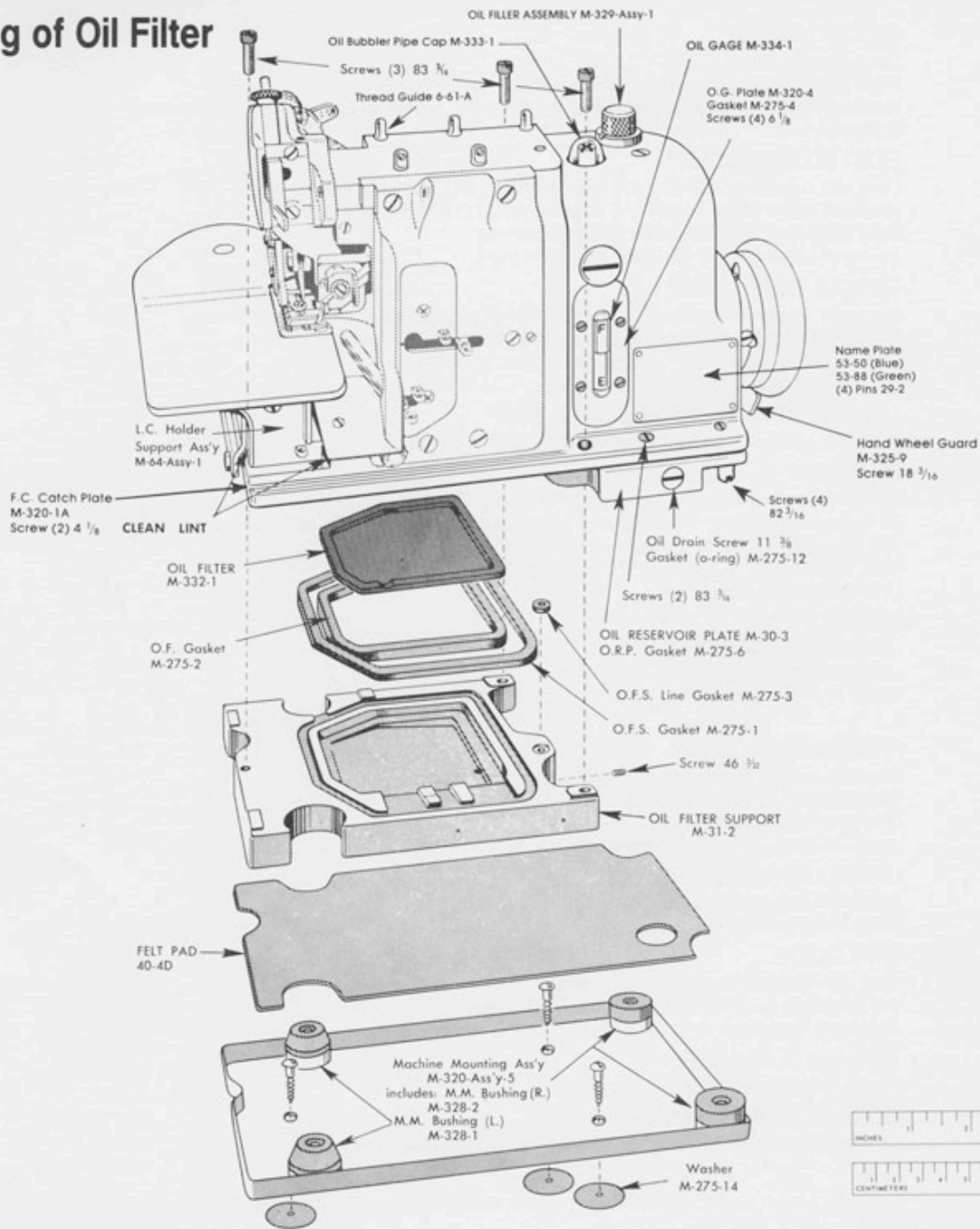

Part No.	GASKET	Illust. Page
M-275-1	Oil Filter Support Gasket	30
M-275-2	Oil Filter Gasket	30
M-275-3	Oil Filter Support Line Gasket	28,30
M-275-4	Oil Gage Gasket	28,30
M-275-5	Oil Pump Plunger Screw Gasket — Discontinued Use M-275-21	
M-275-6	Oil Reservoir Plate Gasket	30
M-275-7	Oil Collector Spring Screw Gasket — Discontinued Use M-275-9	
M-275-8	Cutter Lever Sleeve Support Gasket	28
M-275-9	(O-Ring) Handwheel Seal Gasket and Oil Collector Spring Screw Gasket	28,32
M-275-10	(O-Ring) Upper Cutter Carrier Stud Hole Plug Gasket	28,36
M-275-11	(O-Ring) Upper Shaft Flange Extension Gasket	28,34
M-275-12	(O-Ring) Oil Reservoir Plate Drain Screw Gasket	28,30
M-275-13	(O-Ring) Tube Gasket for M-95-1 with Frame M-1-5	28
M-275-14	Rubber Washer used in M-320-Assy-5	30
M-275-21	Oil Pump Plunger Screw Gasket (Upper and Lower)	32,36

Part No.		Illust. Page
A-278-2	PRESSER FOOT LIFTER STOP CLAMP Used with Screw 16 ¹ / ₈ and Nut 4 ³ / ₁₆	20,36
M-282-1	PLUG Generally used. Fits in Hole for U.C.C. Stud. Used with Screw 89 ³ / ₁₆ , Gasket (O-Ring) M-275-10	36
M-282-2	Supplied in N.C. Link Assembly M-111-Assy-6, 7 or 8	
M-282-4	Heat sink, mounts in place of Plug M-282-1, absorbs and dissipates machine heat through its fins.	
M-308-1	PRESSER BAR LOCK Used with Presser Bar Catch M-270-3 or M-270-4	2,28
A-311-1	LOWER CUTTER HOLDER SUPPORT BLOCK Screw 41 ³ / ₁₆ Used on Style 3DW-3 with slope front Needle Plate like A-70-60	
A-311-2	Generally used on Style 3DW-3, 3DW-4, similar to A-311-1 except support for Work Plate added	8
A-312-1	PRESSER ARM WEDGE Used with Presser Foot Arm A-206-8, Screw 1 ¹ / ₈	34
A-312-2	Used on Presser Foot Arm A-206-5, 6 or 7 to apply more pressure to rear of Presser Foot. Screws (2) 11 ³ / ₃₂	34
A-316-1	BRACKET Used to Mount Tape Tension Guide in A-Assy-10. Used with Thread Guides (2) A-61-9, Nuts (2) 5 ³ / ₁₆	34
A-317-1	TENSION PLATE Used with Tape Guide A-211-2 in A-Assy-10	34
M-318-1	LOWER SHAFT BUSHING Used in left hand end of Lower Shaft, Class MG & M	
M-319-1	CAM ROLL Discontinued — Use M-319-6	
M-319-2	Discontinued — Use M-319-7	
M-319-6	Used with Upper Looper Carriers M-50-Assy-1, M-50-Assy-3 (2 per machine)	4
M-319-7	Used with Lower Looper Carriers M-51-Assy-1, M-51-Assy-3 (1 per machine)	4
M-320-1A	PLATE Feed Cover Catch Plate — Used with Catch M-336-1, Screws (2) 4 ¹ / ₈	30
M-320-4 Gray/Green	Oil Gage Plate — Used with Screws (4) 6 ¹ / ₈ , Gasket M-275-4	30,34
M-320-Assy-5 Gray Green	Machine Mounting Assembly. Includes: M.M. Bushing (Left) (rubber) (2) M-328-1, M.M. Bushing (Right) (rubber) (2) M-328-2, Felt Pad 40-4D, Washer (rubber) (3) M-275-14	30
M-322-Assy-1	UPPER LOOPER CARRIER SLIDE Includes Takeup M-135-1, Class M	4
M-322-Assy-3	Includes Takeup M-135-1, Class MG	4
M-323-1	UPPER LOOPER CARRIER SLIDE ROD Used with U.L.C. Slide M-322-Assy-1 and M-322-Assy-3, Screw (right end) 45 ³ / ₃₂ , Set Screw 80 ³ / ₁₆	4
M-324-1	WORK PLATE STUD Screw 10 ³ / ₁₆	34,36
M-325-1	GUARD Cam Cavity Guard, Screws (2) 33 ⁵ / ₃₂	6,7
M-325-2	Cam End Guard (Lower Cam), Screws (2) 15 ¹ / ₈	6,7
M-325-3	Cam Gear Guard — Discontinued — Use M-325-11	
M-325-7	Cam Cavity for Style M-3DW-SI, Screws (2) 33 ⁵ / ₃₂	
M-325-9	Hand Wheel (Belt) Guard, Screw 18 ³ / ₁₆	2,30
M-325-11	Cam Gear Guard, Screw 49 ⁵ / ₃₂	6,7
M-325-13	Cam Gear Guard — Similar to M-325-11, except relieved for oil tube on Frame M-1-5 — Class M	
M-327-1	HEAD CAP EXTENSION Screws 15 ¹ / ₈ , 53 ³ / ₃₂ Generally used	2,34
M-327-4	Similar to M-327-1 except angle reduced to allow clearance for N.T. Take-up A-112-2 on Style MG-3DW-7	
M-328-1	MACHINE MOUNTING BUSHING M.M. (rubber) Bushing (Left) thicker than M-328-2, Supplied in Plate M-320-Assy-5	30
M-328-2	M.M. (rubber) Bushing (Right) Supplied in Plate M-320-Assy-5	30

From the library of: Diamond Needle Corp

Oiling Parts

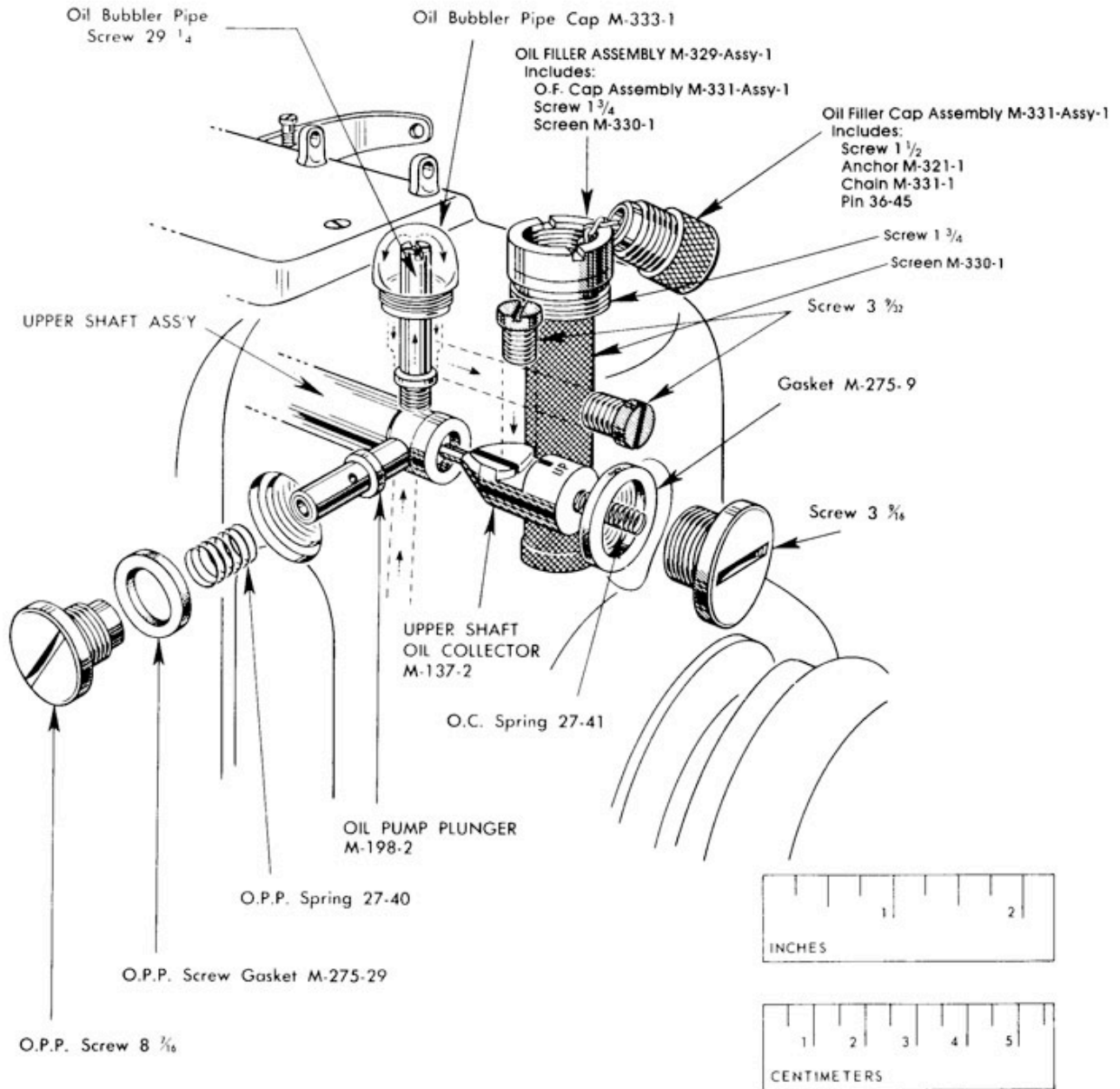

Part No.	OIL FILLER ASSEMBLY	Illust. Page.
M-329-Assy-1	Includes O.F. Cap Assembly M-331-Assy-1, Screw 1 3/4, Screen M-330-1	32
M-331-Assy-1	OIL FILLER CAP ASSEMBLY Includes: Screw 1 1/2, Anchor M-321-2, Chain M-331-1, Pin 36-45	32
M-332-1	OIL FILTER Used with: O.F. Support M-31-2, O.F. Gasket M-275-2	30
M-333-1	OIL BUBBLER CAP Used with Screw 29 1/4 (Oil Bubbler Pipe)	32
M-334-1	OIL GAGE Used with O.G. Gasket M-275-4 and O.G. Plate M-320-4	30,34

Part No.			Illust. Page
PRESSER FOOT LIFTER ROLL			
M-335-1	Used with P.A. Pivot M-33-1 or M-33-3 (O.D. .300)	Screw 90³/₁₆	6,7,36
M-335-2	Used with P.A. Pivot M-33-4 (O.D. .368)		6,7,36
M-335-3	Used with P.A. Pivot M-33-4 (O.D. .420)		6,7,36
FEED COVER CATCH			
M-336-1	Used with F.C.C. Plate M-320-1A, Nut 4 ³ / ₁₆		3,36
UPPER CUTTER CARRIER STUD BUSHING			
		Plunger 37-97	
M-337-1	U.C.C.S. Bushing (Left)	Screw 87³/₁₆	36
M-337-2	U.C.C.S. Bushing (Right)		36
UPPER CUTTER CARRIER THRUST BLOCK			
M-338-1	Generally used. Adjusting Screw 81 ³ / ₁₆ , Clamp Screw 55 ³ / ₁₆		4
UPPER SHAFT FLANGE ASSEMBLY			
		Screws (2) 2⁷/₆₄	
M-339-Assy-5	Supplied in Upper Shaft M-62-Assy-5		
M-339-Assy-5B	Supplied in Upper Shaft M-62-Assy-5B		
M-339-Assy-7	Supplied in Upper Shaft M-62-Assy-7		
M-339-Assy-8	Supplied in Upper Shaft M-62-Assy-8		
M-339-Assy-9	Supplied in Upper Shaft M-62-Assy-9		
M-339-Assy-10	Supplied in Upper Shaft M-62-Assy-10		
M-339-Assy-13	Supplied in Upper Shaft M-62-Assy-13		
M-339-Assy-14	Supplied in Upper Shaft M-62-Assy-14		
M-339-Assy-15B	Supplied in Upper Shaft M-62-Assy-15B		
M-339-Assy-16	Supplied in Upper Shaft M-62-Assy-16		
M-339-Assy-18	Supplied in Upper Shaft M-62-Assy-18		
NEEDLE BEARING			
M-341-1	Supplied assembled in Frame, located in Lower Shaft hole right hand end. Class MG and M		6,7
M-341-2	Used in Upper and Lower Main Cam Bores, left and right hand ends. Class MG (4 per machine)		6

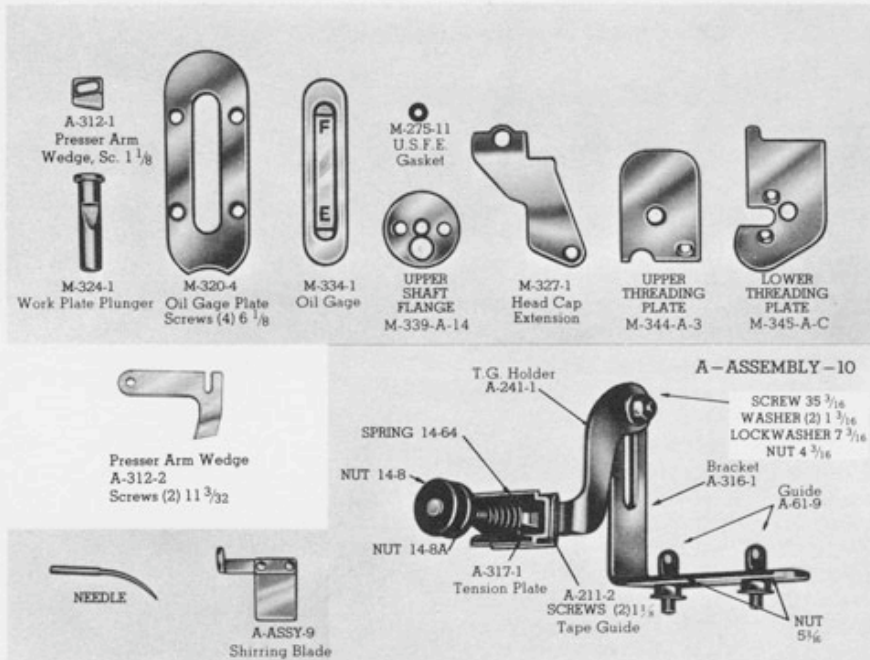

Upper Threading Plates
Screw 1 #6

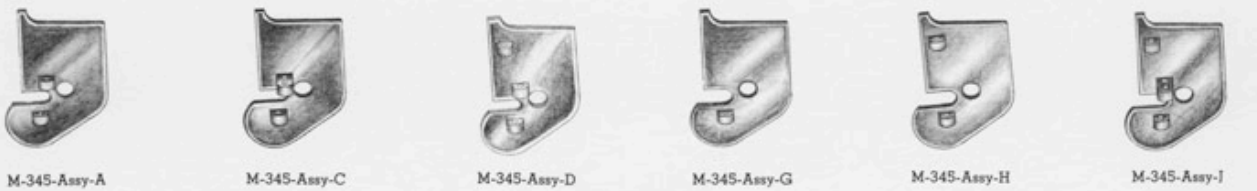

Lower Threading Plates
Screw 1 #6

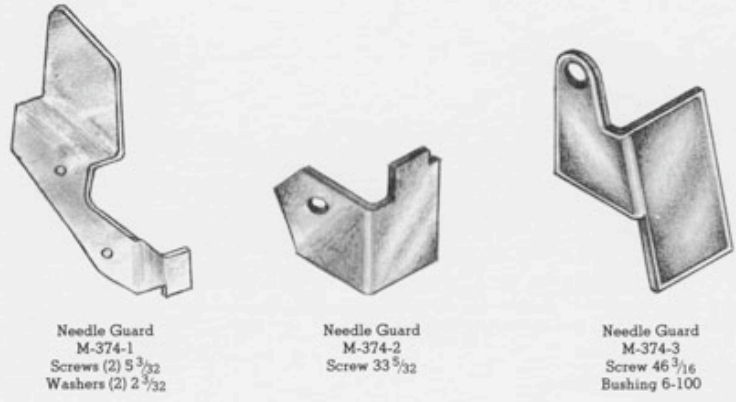

From the library of: Diamond Needle Corp

Part No.	UPPER THREADING PLATE	Screw 1#6	Illust. Page
M-344-Assy-1	One single threading eye		34
M-344-Assy-2	One single threading eye		34
M-344-Assy-3	One double threading eye		34
M-344-Assy-5	Similar to M-344-Assy-3 except double threading eye positioned further to left		34
M-344-6	No threading eye		34
M-344-Assy-8	Similar to M-344-Assy-3, except hole provided for Thread Guide A-61-4		34
M-344-Assy-9	Similar to M-344-Assy-5, except hole provided for Thread Guide A-61-4		34
M-344-Assy-10	Similar to M-344-Assy-1, except one double threading eye		34

	LOWER THREADING PLATE	Screw1#6	
M-345-Assy-A	Two single threading eyes		34
M-345-Assy-C	One double and one single threading eye		34
M-345-Assy-D	Three single threading eyes		34
M-345-Assy-G	One single threading eye		34
M-345-Assy-H	Two single threading eyes		34
M-345-Assy-J	One double and two single threading eyes		34

Threading No.	Federal Stitch No.	No. Threads	Ndl. Thd. Takeup	Upper Plate (Screw 1#6)	Lower Plate (Screw 1#6)	Machine Style	Comments	
38	503	2	A-112-1	M-344-Assy-1	M-345-Assy-A	2D, 2DH-1	Standard two thread	
40	505	3	A-112-1	M-344-Assy-1	M-345-Assy-A	3D, 3DR	Box stitch	
43	504	3	A-112-5	M-344-Assy-3	M-345-Assy-C	3DW, 3DW-4, 3Q	Tight needle thread	
44	503	2	A-112-1	M-344-Assy-2	M-345-Assy-D	2DF	Wide stitch	
52	504	3	A-112-2	M-344-Assy-3	M-345-Assy-C	3DW-2	Extra tight needle thread	
52 Modified	505	3	A-112-2	M-344-Assy-10	M-345-Assy-J	3U	Emblems	
72	502	2	A-112-2	M-344-6	M-345-Assy-G	2DNR-1	Narrow rolled edge	
73	514	4	A-112-7	M-344-Assy-3	M-345-Assy-C	4DW-45	Tight needle thread	
74	514	4	A-112-7	M-344-Assy-3	M-345-Assy-C	4DW-60	Tight needle thread	
75	521	3		M-344-Assy-1	M-345-Assy-A	4D-45	Men's or	
						4D-60	Ladies' Hosiery	
76	512	4	A-112-6	M-344-Assy-3	M-345-Assy-J	4DW-100	Tight needle thread	

UPPER SHAFT OIL DISTRIBUTOR ROD			
M-346-1	Short rod, .1880 diameter supplied in Upper Shaft	Class	6,7
M-346-2	Similar to M-346-1 except .1885 diameter	MG, M	6,7
M-346-3	Similar to M-346-1 except .1890 diameter	MG, M	
M-346-4	Similar to M-346-1 except .1895 diameter	MG, M	
M-346-5	Long Rod, supplied in Upper Shaft	MG, M	6,7
M-346-6	Short Rod — Use M-346-7 or 8		
M-346-7	Similar to M-346-1, except deeper grooves	MG, M	6,7
M-346-8	Similar to M-346-2, except deeper grooves	MG, M	6,7
	Short Rods are selected to fit at factory and should not be changed		
M-346-14	Used in Upper Cam to meter oil flow	M	
M-346-15	Used in Lower Cam to meter oil flow	M	
M-346-16	Used in Lower Cam to meter oil flow	M	
M-346-17	Used in Upper Cam to meter oil flow	MG	6
M-346-18	Used in Lower Cam to meter oil flow	MG	6
M-346-19	Used in Lower Cam to meter oil flow	MG	6
M-346-20	Used in Lower Shafts M-63-Assy-11, 11A, 12, 12A, to meter oil flow	MG	6

FEED CARRIER STABILIZING BLOCK		Screws (2) 16 ⁵ / ₃₂	
M-359-1	Stabilizes rear Feed Carrier on hemming machines		

NEEDLE GUARD		Class	
M-374-1	Screws (2) 5 ³ / ₃₂ , Washers (2) 2 ³ / ₃₂	MG, M	34
M-374-2	Screw 33 ⁵ / ₃₂	70	34
M-374-3	Used with Head M-2-6 (ex. Wheel Foot) Screw 46 ³ / ₁₆ , Bushing 6-100	MG, M	34

MAIN CAM RACE		Class	
M-375-1	Used in Upper and Lower Right Hand Main Cam Bores	MG (2) per machine	6
M-375-2	Used in Upper Left Hand Main Cam Bore	MG (2) per machine	6
M-375-3	Used in Lower Left Hand Main Cam Bore	MG (2) per machine	6

UPPER CAM WAVE WASHER (Blue)		1 ¹⁹ / ₃₂	
	Used in left hand end Upper Main Cam Bore		MG (2) per machine 6

LOWER CAM WAVE WASHER (Bright)		1 ³⁵ / ₆₄	
	Used in left hand end Lower Main Cam Bore		MG (2) per machine 6

From the library of: Diamond Needle Corp

Rear View

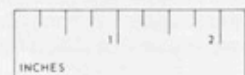
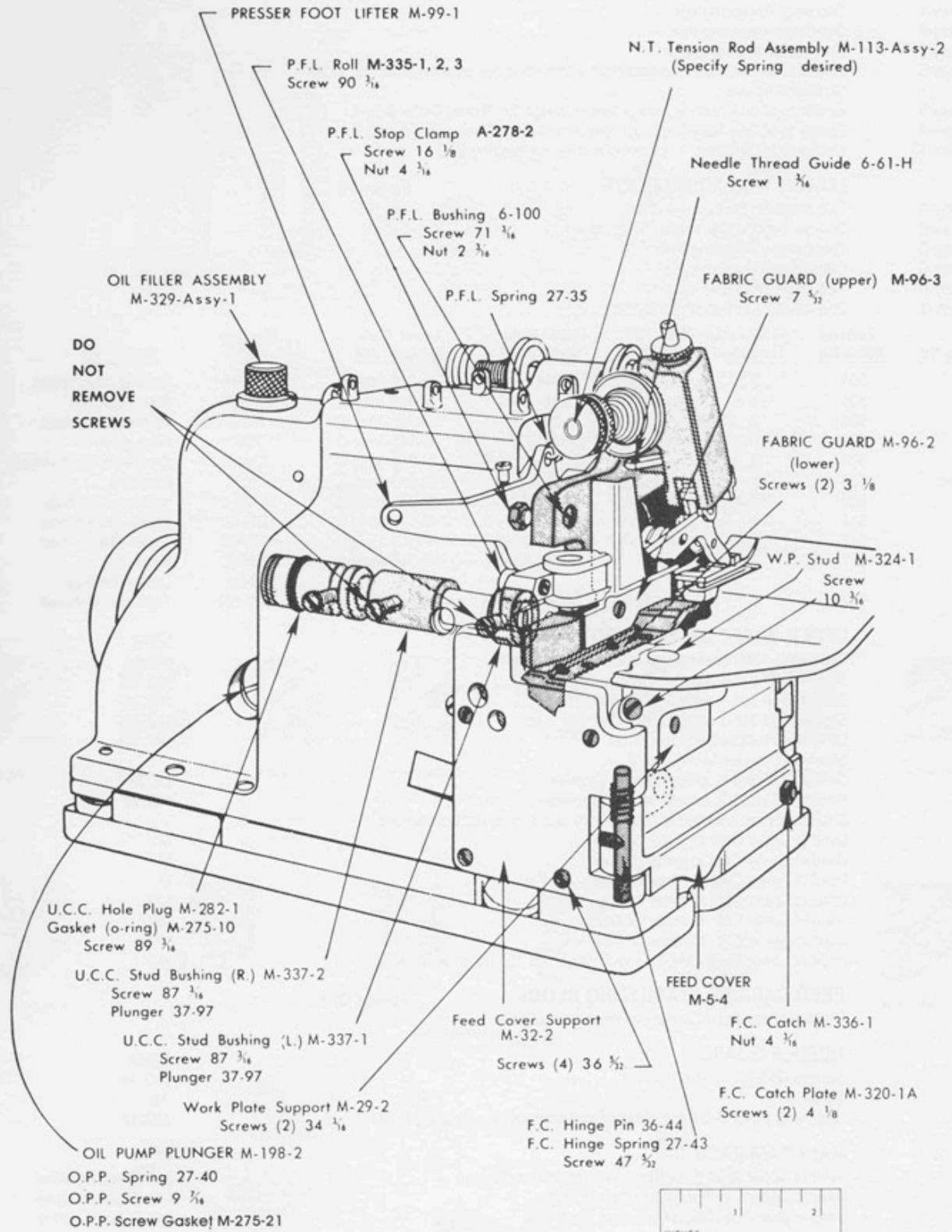

From the library of: Diamond Needle Corp

Part No.	ASSEMBLIES	Illust. Page
6-8 Complete	Swing Edge Guide Complete, consists of Guide 6-8, Bushing 6-117, Support M-119-1, (2) Stop Screw 1 ⁷ / ₃₂ , Pivot Screw 36 ⁷ / ₁₆ , Washer 1 ³ / ₁₆ , Nut 1 ³ / ₁₆ , Support Screw (Long) 93 ³ / ₁₆ , (Short) 50 ³ / ₁₆	3
8-3 Complete	Thread Stand Tension Arm Complete, Green or Gray (Specify Spring), consists of Tension Arm 8-3, T. Rod Shell A-109-1, Tension Rod A-113-1, T. Nut 14-8, T. Nut 14-8A, (2) T. Disc 14-142, (2) Washers 6 ¹ / ₄ , Specify Tension Spring	
8-Assy-10	Tape Stand Complete, consists of (2) Arm 8-4-A, Screws 5 ¹ / ₄ , (2) 20 ¹ / ₄ , 27 ¹ / ₄ (knurled); Base 8-5-A, Screw 35 ⁷ / ₁₆ ; Pivots (2) 8-57; Spool Rod 8-59-B; Rod Cone (2) 8-60, Screws 20 ¹ / ₄ , 27 ¹ / ₄ (knurled); Arm Support 8-61-A	
10-3	Presser Foot Lifter Treadle Assembly, used with Chain 6-195 and Spring 27-18	
A-Assy-8	Tension Rod Assembly, consists of Disc 14-142 soldered to Rod A-113-1, supplied in M-113-Assy-1	
A-Assy-9	Shirring Blade Assembly (light), supplied in Presser Foot Assembly A-71-Assy-34, used with Screw 6 ⁵ / ₃₂ , Washer 1 ⁵ / ₃₂ , Nut 1 ⁵ / ₃₂	34
A-Assy-10	Tape Tension Assembly (1/2" max. width), consists of Bracket A-316-1, T. Guides (2) A-61-9, Nuts (2) 5 ³ / ₁₆ , Holder A-241-1, Screw 35 ⁷ / ₁₆ , Washers (2) 1 ³ / ₁₆ , Lock Washer 7 ³ / ₁₆ , Nut 4 ³ / ₁₆ , Plate A-317-1, Spring 14-64, T. Nut 14-8, T. Nut 14-8A; Tape Guide A-211-2, Screws (2) 1 ¹ / ₈	34
A-Assy-11	Tape Tension Assembly similar to A-Assy-10 except for mounting on Support M-119-1 with Screws 45 ⁷ / ₁₆ , 50 ³ / ₁₆ , 93 ³ / ₁₆ and Nut 1 ³ / ₁₆	
A-Assy-12	Shirring Blade Assembly (heavy), similar to A-Assy-9, except heavier blade and longer blade arm	
A-Assy-13	Shirring Blade Assembly (light), similar to A-Assy-9, except longer blade arm	
A-Assy-14	Lower Cutter Holder Assembly, consists of L.C. Holder A-65-1, L.C. Clamp A-67-1, Nut 2 ⁵ / ₃₂ . Used on style M-3DW-SI with L.C.H. Support M-64-Assy-5	
A-Assy-18	Tape Tension Assembly (1 1/2" max. width) Adjustable Tension and position	
A-146-1 Complete	Wheel Presser Foot (Small) Complete, consists of Presser Wheel A-146-1, Stud 54 ⁵ / ₃₂ , Nut 7 ⁵ / ₃₂ ; P.W. Arm A-206-11; P.W. Guard A-148-1, Screw 8 ¹ / ₈ ; Head Cap M-89-5; H.C. Extension M-327-5; P.W. Arm Stop M-373-2, Screws (2) 9 ¹ / ₈ ; Presser Bar Latch A-270-1; Needle Carrier Collar M-126-5; Needle Carrier Nut 9 ³ / ₁₆ ; Needle Carrier Bolt M-128-3	
6-146-D Complete	Wheel Presser Foot (Large) Complete, consists of Presser Wheel 6-146-D, Taper Stud 59 ³ / ₁₆ , Nut 4 ³ / ₁₆ ; P.W. Shank 6-147-E, Screw 6 ³ / ₃₂ , Screw 10 ¹ / ₈ ; P.W. Guard 6-148-F or EXC-646, Screw 10 ³ / ₃₂	
6-146-E Complete	Wheel Presser Foot (Large) Complete, same as above, except use Presser Wheel 6-146-E, which is similar to Presser Wheel 6-146-D but has axial grooves added for better traction	
Hemming Attachments	#1, #2, #3, #4, #4B, #5, #7, #8, #BA-3	
Hoisery Welt Folder	Complete (Regular) — Used to fold hems	
Hoisery Welt Folder	Complete (Small) — Used to fold hems	
MISCELLANEOUS		
6-195	Presser Foot Lifter Chain	
14-8	Tension Nut	26
14-8A	Tension Nut	26
14-142	Tension Disc	26
37-318	Threading Wire	41
37-225-B	Tweezer	41
40-4D	Felt Pad — Used in Machine Mounting Plate M-320-Assy-5	30
53-50	Name Plate — Blue — Class M (4 Pins 29-2)	2,30
53-88	Name Plate — Green — Class MG (4 Pins 29-2)	2,30
EXC-263	Border Roll Stand — Used for border rolls, cord and piping	
EXC-263A	Border Roll Stand — Used for border rolls	

NEEDLE TERMS

A	as in A.1D	flat on both sides of shank (.060 thick)
B	as in B.ODE	flat on both sides of shank (.045 thick)
B	as in 4BDF	bulge eye
D	as in 1D	curved needle
E	as in B.1DE	long blade, short shank
F	as in 3SDF	ball point
G	as in 8DG	spear point
J	as in 5DJ	groove on inside of curve
S	as in 2SD	spot or scarf on needle
T	as in 3DT	tapered blade

NEEDLES (Chrome — 25 per package)

Standard

000D
00D
0D
1D
2D
3D
4D
5D
8D

Tapered Blade

000DT
0DT
1SDT Also scarfed
2SDT Also scarfed
3SDT Also scarfed
4DT
6DT
7SDT Also scarfed

Ball Point

0DF
1DF
1SDTF Also scarfed and tapered
2DF
3SDF Also scarfed
4DF
4BDF Also bulge eye

Scarfed or Spotted

1SD
2SD
3SD
7SDT Also tapered
8SD

Long Blade

Short Shank

00DE
0DE
1DE
3DE
5DE

Kooltorr

3D
4D
5D
A.4D
A.5D

Specials

4BD Bulge eye
5DJ Groove on
inside of curve
8DG Spear point

Two Needle (60 or 100 Machine)

A.0D
A.1D
A.2D
A.2DF Ball point
A.2SD Scarfed
A.3D
A.3SDF Scarfed, ball point
A.4D
A.4DF Ball point
A.4BDF Bulge eye, ball point
A.5D
A.5DF Ball point

Two Needle (45 Machine)

B.00DE Long blade, short shank
B.00DT Tapered blade
B.0DE Long blade, short shank
B.0SDT Scarfed, tapered blade
B.1SDT Scarfed, tapered blade
B.1DE Long blade, short shank
B.1SD Scarfed
B.1DF Ball point
B.2SD Scarfed

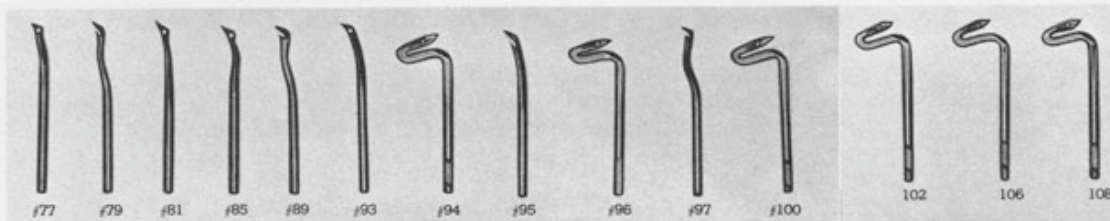

LOOPERS

Upper

77	Eye
79	Throat
81	Eye
85	Eye
89	Throat
93	Eye
95	Eye
97	Throat
99	Eye
103	Throat

Use

Generally used — 3 thread
 Generally used — 2 thread
 3DWL
 3DNR-1, 3U
 2DNR-1
 4DW-60 and 3 thread machines
 4DW-100
 4D-45 Men's and Ladie's, 4D-60 Men's
 Similar to 77 except angled to provide more clearance over material

Lower

82	No eye, hooked
84	Eye
90	Eye
92	No eye, hooked
94	Eye
96	Eye
100	Eye
102	Eye
106	Eye
108	Eye
110	Eye
120	Eye

A-1, A-1D
 A-3DW
 A-3DW-2,3,4
 -1, -1D
 2DH-1, 3DR, 3DW, 3Q, 3U
 4DW-100
 3DW-2, 3, 4, 4DW-60
 4D-45 Men's and Ladie's, 4D-60 Men's
 Similar to 102, except shank .025 longer, 2DNR-1
 Similar to 94, except shank .025 longer, 3DWL
 Similar to 100, except shank .035 shorter, 3DW-6
 Similar to 100, except shank .060 shorter, 3DW-7

CARBIDE TIPPED CUTTERS

Part No.	Similar Cutter	Description
A-90-8	A-90-3	Upper Cutter
6-90-Q	6-90-D	Upper Cutter
6-90-R	6-90-F	Upper Cutter
6-90-S	6-90-C	Upper Cutter
EXC-314-1	6-90	Upper Cutter
EXC-314-3	6-90-K	Upper Cutter
EXC-314-5	6-90-J	Upper Cutter
EXC-314-8	A-90-5	Upper Cutter
EXC-314-9	A-90-7	Upper Cutter
6-91-L	6-91-E	Lower Cutter
6-91-M	6-91	Lower Cutter
6-91-N	6-91-H	Lower Cutter
EXC-315-9	6-91-F	Lower Cutter
EXC-315-15	6-91-G	Lower Cutter

Above cannot be sharpened on Merrow Cutter Grinder

RUBBER TIPPED FEED DOGS

Part No.	Similar Feed Dog	Description
A-81-74	A-81-8	Rear differential, single row, with integral ear
A-81-75	A-81-11	Front differential, single row
A-81-76	A-81-43	Rear differential, single row
EXC-429-2	A-81-2	Front differential, double row
EXC-429-3C	A-81-3C	Rear differential, double row, chain cutter
EXC-429-7	A-81-7	Rear differential, double row
EXC-429-20	A-81-20	Non-differential, single row
EXC-429-59	A-81-59	Front differential, double row
EXC-429-497	A-81-78	Rear differential, for long seam
EXC-429-497-1	A-81-79	Front differential, for long seam
EXC-429-497-7	A-81-80	Front differential, for long seam
EXC-530-190	A-81-43C	Rear differential, single row, chain cutter

COMMON NUTS AND SCREWS

NUTS

Feed Carrier Link Bolt	2 ³ / ₁₆
Lower Cutter Clamp	2 ⁹ / ₃₂
Lower Looper Carrier	1 ⁹ / ₃₂
Needle Carrier	4 ³ / ₁₆
Presser Foot Arm	1 ⁹ / ₃₂

SCREWS

Dust Shield	2 ¹ / ₈
Fabric Guard (Upper)	7 ⁵ / ₃₂
Feed Dog (Differential)	11 ⁷ / ₃₂
Feed Dog (Non-differential)	16 ³ / ₁₆
Feed Dog Ear	8 ¹ / ₈ or 17 ¹ / ₈
Frame Cap	99 ³ / ₁₆
Hand Wheel	30 ¹ / ₄ Cone Point, 9 ⁷ / ₃₂ Oval Point
Head	91 ⁷ / ₁₆
Head Cap	36 ⁵ / ₃₂ , 53 ⁵ / ₃₂
Hem Fold Guide	5 ¹ / ₈ or 6 ¹ / ₈
Lower Looper Carrier	1 ⁷ / ₃₂
Lower Looper Carrier STUD	2 ⁹ / ₃₂
Main Cam — Upper	32 ¹ / ₄ , 4 ¹ / ₄
Main Cam — Lower	32 ¹ / ₄ , 9 ¹ / ₄
Needle Carrier STUD	4 ⁹ / ₃₂
Needle Plate	7 ⁵ / ₃₂
Needle Thread Takeup	1 ⁷ / ₆₄
Presser Foot Arm	35 ⁵ / ₃₂
Presser Foot Finger	3 ¹ / ₈ (Rigid)
Presser Foot Finger	9 ¹ / ₈ (Spring)
Presser Foot Uncurling Block	12 ³ / ₃₂
Thread Cutter	11 ³ / ₃₂
Upper Cutter Clamp (Wide)	37 ³ / ₃₂
Upper Cutter Clamp (Narrow)	38 ⁵ / ₃₂
Upper Cutter Holder	8 ¹ / ₈
Upper Looper Carrier	100 ³ / ₁₆

Part No.

SPRINGS

14-64	Tension Spring — heavy	26
14-64A	Tension Spring — very heavy	
14-760	Tension Spring — light	
27-46	Tension Spring — very light	
27-33	Presser Foot Spring — light	28
27-34	Presser Foot Spring — medium	
27-36	Presser Foot Spring — heavy	
27-45	Presser Foot Spring — heavy — flat wire	
27-18	Presser Foot Lifter Treadle Spring	
27-21	Spring in L.C. Holder Support M-64-Assy-1	8
27-35	Presser Foot Lifter Spring	20
27-40	Oil Pump Plunger Spring	32
27-41	Oil Collector Spring	32
27-42	Work Plate Plunger Spring	
27-43	Feed Cover Spring	3,36

Part No.

PINS

Use

29-2	Name Plate
36-39	Lower Looper Carrier M-51-Assy-1, 3, Feed Carrier M-74-2, 3, 5, 7
36-40	Feed Carrier M-74-1
36-41	Upper Cutter Carrier M-52-Assy-1
36-47	Upper Looper Carrier M-50-Assy-1, 3
36-58	With Web A-70-89 in Needle Plates A-70-90, 91, 101, 102
36-60	Needle Carrier

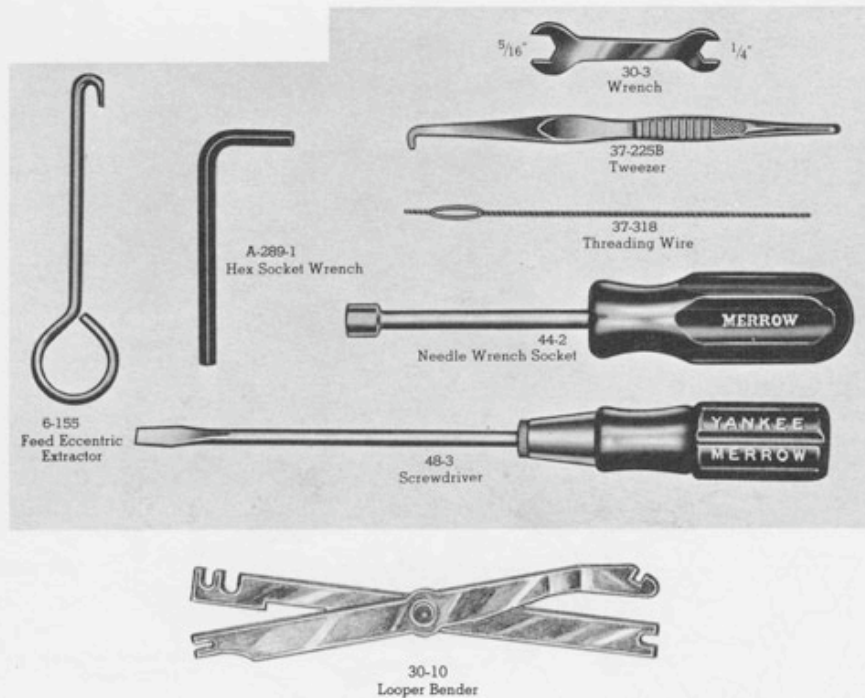

Part No.

- 6-155
- 30-3
- 30-7
- 30-10
- 37-318
- 37-225-B
- 44-2
- 44-3
- 48-3
- A-289-1
- A-289-3
- M-155-Assy-1
- Dow #7 Corning Compound
- EXC-503
- EXC-503-1
- EXC-503-2
- EXC-503-3

TOOLS-ACCESSORIES

- Feed Eccentric Extractor
- Wrench, Small Open End (Flat) 1/4" and 5/16" Openings
- Wrench, Small Open End (Bent) 1/4" and 5/16" Openings
- Looper Bender
- Threading Wires
- Tweezers
- Wrench Socket with Handle
- Wrench Socket with Handle
- Screw Driver
- Hex Socket Wrench
- Hex Socket Wrench
- Main Cam Extractor
- Gasket Compound
- Needle Bearing Instruction Sheet
- Dummy Lower Shaft
- Oval Key
- Needle Bearing Installation Tool

Use

- To remove Feed Eccentric
- Feed Eccentric Nut 2 3/16 and other small nuts
- Feed Eccentric Nut 2 3/16 and other small nuts
- Adjustment of Loopers
- Needle Carrier Nut 4 3/16
- Feed Eccentric Nut 2 3/16
- Main Cam Socket Screw 3 1/4
- Chain Cutter Trimmer Assembly Cap Screw
- To remove Upper and Lower Main Cams
- Needle Bearing removal and replacement in the field
- To drive Oval Key EXC-503-2 against Needle Bearing
- Pressure plate for edges of Needle Bearing
- Pressure fitting of Needle Bearing into Frame

Illust. Page

41
41
41
41
41
41
41
41
41
41

MAIN CAMS — CLASS MG

- Upper
- M-142A
 - M-146A
 - M-148A

- Lower
- M-143-145A
 - M-147-144A
 - M-149-150B

- Use
- All Styles except 2DNR-1, 3DNR-1, 3DW-7, 4DW-67, 4DW-107
 - Styles 3DW-7, 4DW-67, 4DW-107
 - Styles 2DNR-1, 3DNR-1

Upper Cam — Screw 3 1/4 Cone Point, Screw 4 1/4
Lower Cam — Screw 3 1/4 Cone Point, Screw 9 1/4

MAIN CAMS — CLASS M

- Upper
- M-135
 - M-138
 - M-142
 - M-142

- Lower
- M-133-134
 - M-139-141
 - M-143-134
 - M-143-144

- Use
- Styles 2DH-1, 3DR, 3DW, 3U, 4D-45 Men's and Ladies', 3Q
 - Styles 2DNR-1
 - Styles 3DW-2, 3DW-3, 3DW-4, 4DW-60, 3Q-3
 - Style 4DW-100

Upper Cam — Screw 3 1/4 Cone Point, Screw 4 1/4
Lower Cam — Screw 3 1/4 Cone Point, Screw 9 1/4

Styles M-3Q, M-3Q-3

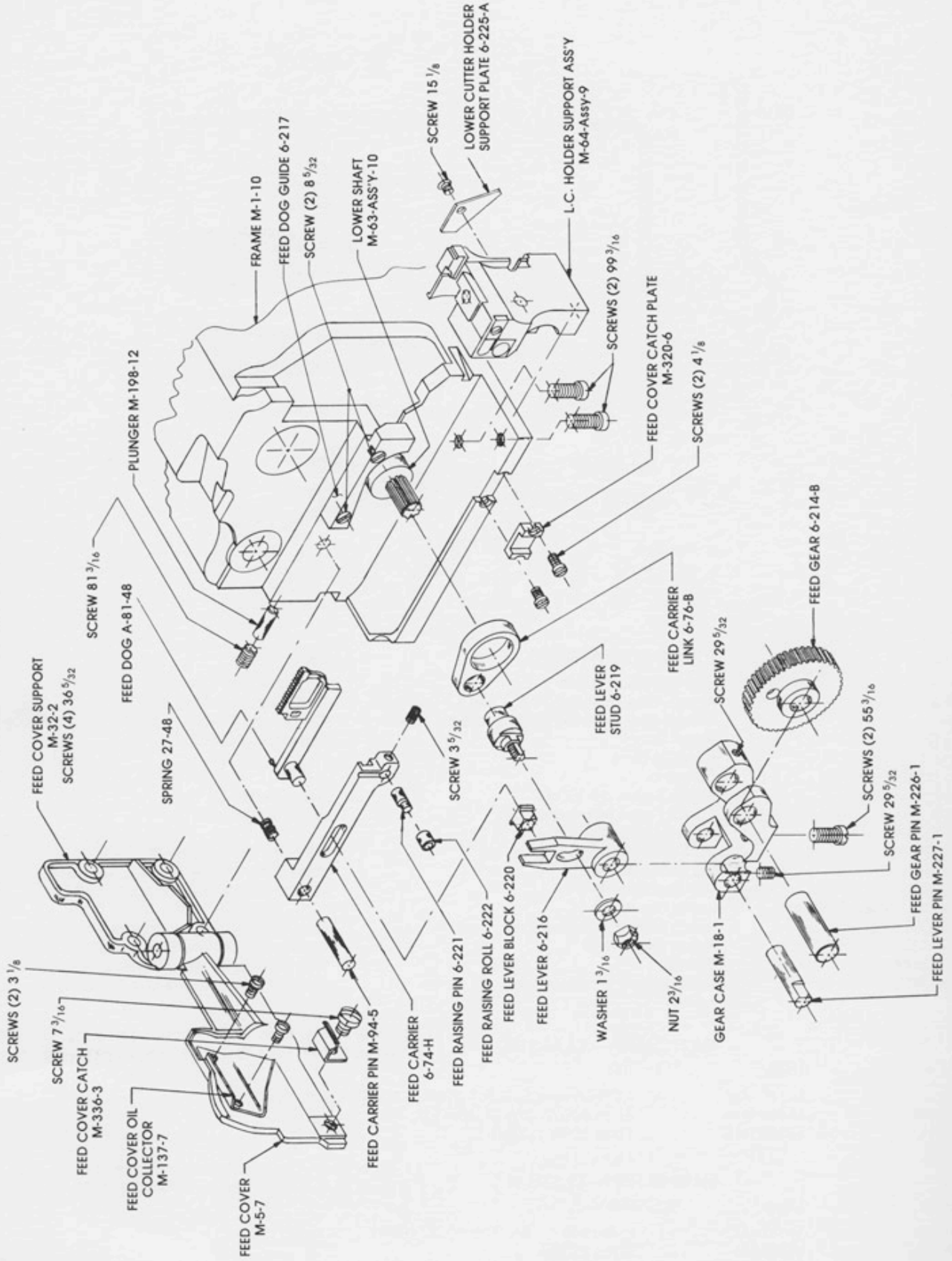

Q-PARTS
Alphabetical Index

Part No.		Illust. Page
6-74-H	Feed Carrier	42
6-76-B	Feed Carrier Link	42
M-94-5	Feed Carrier Pin	42
M-5-7	Feed Cover	42
M-336-3	Feed Cover Catch — Screw $7\frac{3}{16}$	42
M-320-6	Feed Cover Catch Plate — Screws (2) $4\frac{1}{8}$	42
M-137-7	Feed Cover Oil Collector — Screws (2) $3\frac{1}{8}$	42
M-32-2	Feed Cover Support — Screws (4) $36\frac{5}{32}$	42
A-81-45	Feed Dog M-3Q	
A-81-48	Feed Dog M-3Q-3	42
A-81-82	Feed Dog M-3Q-3	
6-217	Feed Dog Guide — Screws (2) $8\frac{5}{32}$	42
6-214-B	Feed Gear	42
M-226-1	Feed Gear Pin	42
6-216	Feed Lever	42
6-220	Feed Lever Block	42
M-227-1	Feed Lever Pin	42
6-219	Feed Lever Stud — Washer $1\frac{3}{16}$, Nut $2\frac{3}{16}$	42
6-221	Feed Raising Pin	42
6-222	Feed Raising Roll	42
M-1-10	Frame	42
M-18-1	Gear Case — Screws (2) $55\frac{3}{16}$, (2) $29\frac{5}{32}$	42
6-Assy-11	Lower Cutter Holder Assembly — Includes: L. C. Holder 6-65-7, L. C. Clamp 6-67-B, Nut $2\frac{5}{32}$	
6-66-D	Lower Cutter Holder Clamp — Screw $10\frac{3}{16}$	
6-185-A	Lower Cutter Holder Spring Stop — Screw $2\frac{5}{32}$	
M-64-Assy-9	Lower Cutter Holder Support — Screws (2) $99\frac{3}{16}$	42
6-225-A	Lower Cutter Holder Support Plate — Screw $15\frac{1}{8}$	42
A-69-7	Lower Looper Thread Tube M-3Q	
A-69-16	Lower Looper Thread Tube M-3Q-3	
M-63-Assy-10	Lower Shaft	42
A-70-81	Needle Plate M-3Q-3 — $\frac{3}{16}$ " stitch width	
A-70-84	Needle Plate M-3Q — $\frac{1}{8}$ " stitch width	
A-70-107	Needle Plate M-3Q — $\frac{1}{16}$ " stitch width	
A-70-108	Needle Plate M-3Q-3 — $\frac{3}{16}$ " stitch width	
M-198-12	Plunger — Screw $81\frac{3}{16}$	42
A-71-12	Presser Foot M-3Q	
A-71-48	Presser Foot M-3Q-3	
27-48	Spring	42
A-61-10	Thread Guide	
M-29-10	Work Plate Support — Screws (2) $34\frac{3}{16}$	

Chain Cutter Assembly

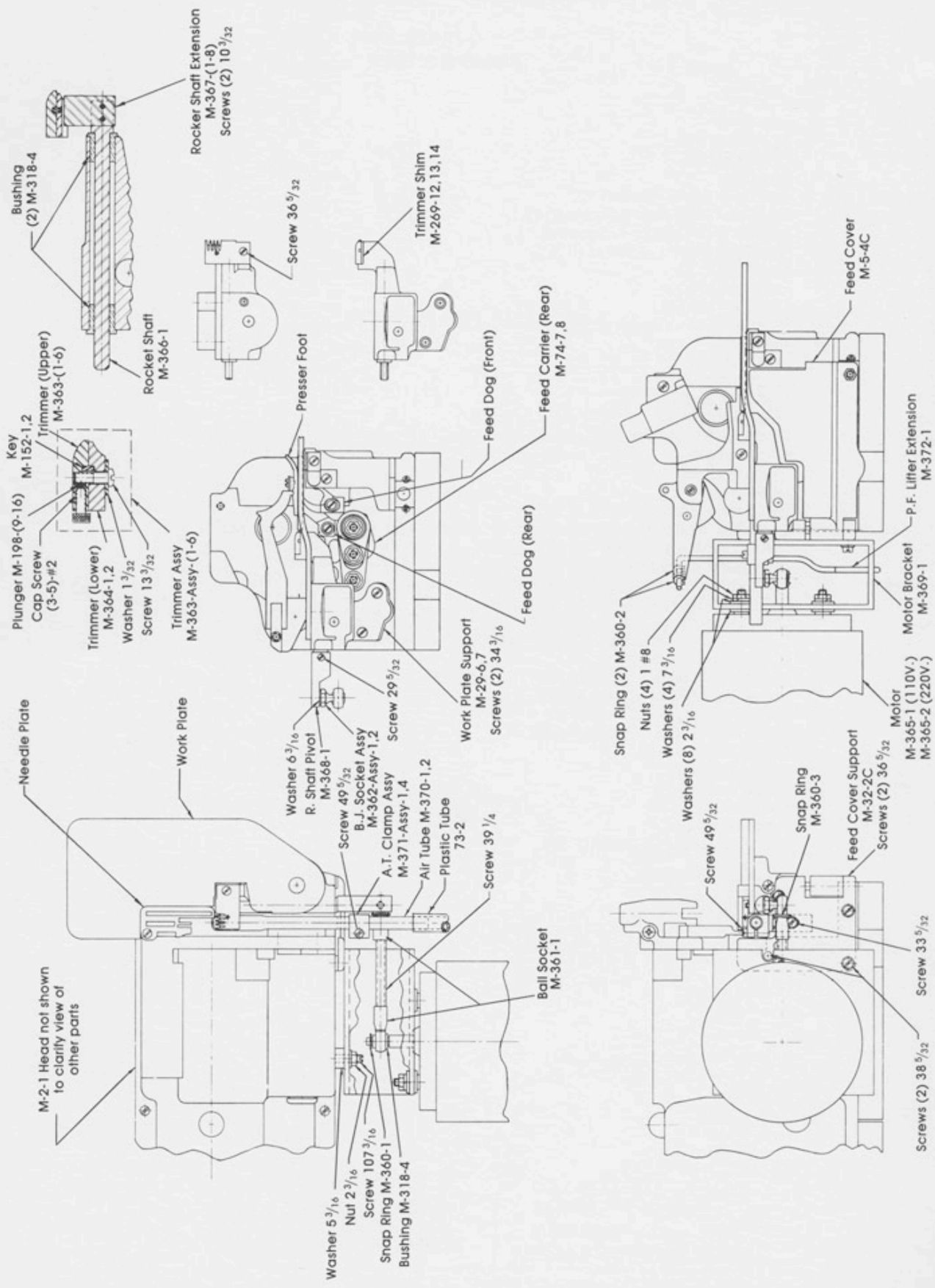

M-2-1 Head not shown to clarify view of other parts

CHAIN CUTTER PARTS
Alphabetical Index

Part No.		Similar Standard Part No.	Comments	Illust. Page
M-370-1	Air Tube		Small	44
M-370-2	Air Tube		Large	44
M-371-Assy-1	Air Tube Clamp Assembly		Small, Sc. 49 ⁵ / ₃₂	44
M-371-Assy-4	Air Tube Clamp Assembly		Large, Sc. 49 ⁵ / ₃₂	44
M-362-Assy-1	Ball Joint and Socket Assembly		Used with 4-Tooth Trimmer Assy	44
M-362-Assy-2	Ball Joint and Socket Assembly		Used with 3-Tooth Trimmer Assy	44
M-361-1	Ball Socket		Used on both ends of Screw 39 ¹ / ₄	44
M-318-4	Bushing-Bronze		Used in Ball Socket M-361-1 and W.P. Support M-29-6 & 7	44
M-74-7	Feed Carrier — Rear	M-74-3	Feed Dog Screw hole lower	44
M-74-8	Feed Carrier — Rear	M-74-6	Used on Hemming Machines with M-359-1 F.C. Stabilizing Block	44
M-5-4C	Feed Cover	M-5-4		44
M-32-2C	Feed Cover Support	M-32-2	Sc. (2) 36 ⁵ / ₃₂	44
A-81-1C	Feed Dog	A-81-1	Front differential, double row, coarse	
A-81-2C	Feed Dog	A-81-2	Front differential, double row, fine	
A-81-3C	Feed Dog	A-81-3	Rear differential double row, coarse	
A-81-4C	Feed Dog	A-81-4	Rear differential double row, fine	
A-81-9C	Feed Dog	A-81-9	Front differential, double row, coarse	
A-81-15C	Feed Dog	A-81-15	Front differential, double row, fine	
A-81-16C	Feed Dog	A-81-16	Non-differential, single row, coarse	
A-81-19C	Feed Dog	A-81-19	Front differential, double row, fine	
A-81-20C	Feed Dog	A-81-20	Non-differential single row, fine	
A-81-22C	Feed Dog	A-81-22	Rear Differential, double row, coarse	
A-81-23C	Feed Dog	A-81-23	Front differential, double row, coarse	
A-81-28C	Feed Dog	A-81-28	Front differential, double row, coarse	
A-81-36C	Feed Dog	A-81-36	Front differential, double row, coarse	
A-81-40C	Feed Dog	A-81-40	Front differential, double row, fine	
A-81-43C	Feed Dog	A-81-43	Rear differential single row, fine	
A-81-44C	Feed Dog	A-81-44	Rear differential single row, coarse	
A-81-46C	Feed Dog	A-81-46	Front differential, double row, coarse	
A-81-47C	Feed Dog	A-81-47	Front differential, double row, fine	
A-81-55C	Feed Dog	A-81-55	Front differential, double row, coarse	
A-81-56C	Feed Dog	A-81-56	Front differential, double row, fine	
A-81-57C	Feed Dog	A-81-57	Front differential, double row, coarse	
A-81-58C	Feed Dog	A-81-58	Front differential, double row, coarse	
A-81-59C	Feed Dog	A-81-59	Front differential, double row, fine	
EXC-530-190	Feed Dog	A-81-43	Rear differential, single row, Polyurethane tipped	
A-81-62	Feed Dog Ear		4-Teeth	
A-81-81	Feed Dog Ear		Use on Style MG-4D-45 Men's	
M-365-1	Motor (110 Volt)		Washer (4) 7 ⁷ / ₁₆ , Washer (4) 2 ⁷ / ₁₆ , Nut (4) 1#8	44
M-365-2	Motor (220 Volt)		Same as above	44
M-369-1	Motor Bracket		Sc. 38 ⁵ / ₃₂ , 38 ⁵ / ₃₂ , 107 ³ / ₁₆ , Washer 5 ³ / ₁₆ , Nut 2 ³ / ₁₆	44
A-70-1C	Needle Plate	A-70-1	*A-Double row	
A-70-14C	Needle Plate	A-70-14	*A-Double row	
A-70-15C	Needle Plate	A-70-15	*A-Double row	
A-70-16C	Needle Plate	A-70-16	*A-Double row	
A-70-17C	Needle Plate	A-70-17	*A-Double row	
A-70-30C	Needle Plate	A-70-30	*B-Single row	
A-70-38C	Needle Plate	A-70-38	*B-Single row	
A-70-46C	Needle Plate	A-70-46	*B-Single row	
A-70-51C	Needle Plate	A-70-51	*B-Single row	
A-70-54C	Needle Plate	A-70-54	*A-Double row	
A-70-58C	Needle Plate	A-70-58	*B-Single row	
A-70-60CC	Needle Plate	A-70-60C	*A-Double row	
A-70-60D	Needle Plate	A-70-60	*A-Double row	
A-70-67BC	Needle Plate	A-70-67B	*A-Double row	
A-70-67CC	Needle Plate	A-70-67C	*A-Double row	
A-70-70C	Needle Plate	A-70-70	*A-Double row	
A-70-73C	Needle Plate	A-70-73	*B-Single row	
A-70-85C	Needle Plate	A-70-85	*B-Single row	

*A—Double Row: Web removed between Rear Feed Dog and Feed Dog Ear

*B—Single Row: Step added to Feed Dog slot

CHAIN CUTTER PARTS Alphabetical Index

Illust.
Page

Part No.		Similar Standard Part No.	Comments	
A-70-87C	Needle Plate	A-70-87	*B-Single row	
A-70-90C	Needle Plate	A-70-90	*B-Single row	
A-70-91C	Needle Plate	A-70-91	*B-Single row	
A-70-101C	Needle Plate	A-70-101	*B-Single row	
A-70-102C	Needle Plate	A-70-102	*B-Single row	
A-71-9C	Presser Foot	A-71-9	Added Heel Extension	
A-71-11C	Presser Foot	A-71-11	Added Heel Extension	
A-71-12C	Presser Foot	A-71-12	Added Heel Extension	
A-71-17C	Presser Foot	A-71-17	Added Heel Extension	
A-71-32C	Presser Foot	A-71-32	Added Heel Extension	
M-372-1	Presser Foot Lifter Extension			44
M-366-1	Rocker Shaft			44
M-367-1	Rocker Shaft Extension		Use with 4-Tooth Trimmer Assy. Sc. (2) 10 ³ / ₃₂	44
M-367-2	Rocker Shaft Extension		Use with 4-Tooth Trimmer Assy. Sc. (2) 10 ³ / ₃₂	44
M-367-3	Rocker Shaft Extension		Use with 4-Tooth Trimmer Assy. Sc. (2) 10 ³ / ₃₂	44
M-367-4	Rocker Shaft Extension		Use with 4-Tooth Trimmer Assy. Sc. (2) 10 ³ / ₃₂	44
M-367-5	Rocker Shaft Extension		Use with 3-Tooth Trimmer Assy. Sc. (2) 10 ³ / ₃₂	44
M-367-6	Rocker Shaft Extension		Use with 3-Tooth Trimmer Assy. Sc. (2) 10 ³ / ₃₂	44
M-367-7	Rocker Shaft Extension		Use with 3-Tooth Trimmer Assy. Sc. (2) 10 ³ / ₃₂	44
M-367-8	Rocker Shaft Extension		Use with 3-Tooth Trimmer Assy. Sc. (2) 10 ³ / ₃₂	44
M-368-1	Rocker Shaft Pivot		Used to drive Rocker Arm M-366-1, Sc. 29 ³ / ₃₂	44
39 ¹ / ₄	Screw		Used between Ball Sockets M-361-1	44
M-360-1	Snap Ring		Used on Motor M-365-1 & 2	44
M-360-2	Snap Ring		Used to hold P.F.L. Extension M-372-1 to P.F. Lifter M-99-1	44
M-360-3	Snap Ring		Used on M-362 to provide tight Ball & Socket Assy	44
M-364-1	Trimmer (Lower Only)		4-Tooth	44
M-364-2	Trimmer (Lower Only)		3-Tooth	44
M-363-1	Trimmer (Upper Only)		4-Tooth	44
M-363-2	Trimmer (Upper Only)		4-Tooth	44
M-363-3	Trimmer (Upper Only)		4-Tooth	44
M-363-4	Trimmer (Upper Only)		3-Tooth	44
M-363-5	Trimmer (Upper Only)		3-Tooth	44
M-363-6	Trimmer (Upper Only)		3-Tooth	44
M-363-Assy-1	Trimmer Assembly		4-Tooth, Sc. 36 ⁵ / ₃₂	44,48
M-363-Assy-2	Trimmer Assembly		4-Tooth, Sc. 36 ⁵ / ₃₂	44,48
M-363-Assy-3	Trimmer Assembly		4-Tooth, Sc. 36 ⁵ / ₃₂	44,48
M-363-Assy-4	Trimmer Assembly		3-Tooth, Sc. 36 ⁵ / ₃₂	44,48
M-363-Assy-5	Trimmer Assembly		3-Tooth, Sc. 36 ⁵ / ₃₂	44,48
M-363-Assy-6	Trimmer Assembly		3-Tooth, Sc. 36 ⁵ / ₃₂	44,48
A-107-6	Trimmer Guard		Used to produce longer thread chain – single row	
A-107-7	Trimmer Guard		Used to produce longer thread chain – double row	
A-107-8	Trimmer Guard	A-107-6	Narrower protruding finger	
M-152-1	Trimmer Key		Used in Trimmer Assy	44
M-152-2	Trimmer Key		Used in place of M-152-1 when trimmers are worn	44
M-198-9	Trimmer Plunger		Used in Trimmer Assy M-363-Assy-1	44
M-198-10	Trimmer Plunger		Used in Trimmer Assy M-363-Assy-2	44
M-198-11	Trimmer Plunger		Used in Trimmer Assy M-363-Assy-3 and M-363-Assy-6	44
M-198-13	Trimmer Plunger		Used in Trimmer Assy M-363-Assy-4	44
M-198-14	Trimmer Plunger		Used in Trimmer Assy M-363-Assy-4	44
M-198-16	Trimmer Plunger		Used in Trimmer Assy M-363-Assy-5	44
M-269-12	Trimmer Shim .0625			44
M-269-13	Trimmer Shim .0468			44
M-269-14	Trimmer Shim .0156			44
M-96-6	Upper Fabric Guard	M-96-3		
M-84-1C	Work Plate	M-84-1	Straight, use Trimmer M-363-Assy-1	
M-84-2C	Work Plate	M-84-2	Curved, use Trimmer M-363-Assy-1	
M-84-3C	Work Plate	M-84-3	Curved, use Trimmer M-363-Assy-2	
M-84-3D	Work Plate	M-84-3	Curved, use Trimmer M-363-Assy-3	
M-84-4C	Work Plate	M-84-4	Straight, use Trimmer M-363-Assy-1	

*A—Double Row: Web removed between Rear Feed Dog and Feed Dog Ear

*B—Single Row: Step added to Feed Dog slot

From the library of: Diamond Needle Corp

**CHAIN CUTTER PARTS
Alphabetical Index**

**Illust.
Page**

Part No.		Similar Standard Part No.	Comments	
M-84-4D	Work Plate	M-84-4	Straight, use Trimmer M-363-Assy-3	
M-84-5C	Work Plate	M-84-5	Straight, use Trimmer M-363-Assy-1	
M-84-6C	Work Plate	M-84-6	Straight-Hemming use Trimmer M-363-Assy-1	
M-84-7C	Work Plate	M-84-7	Straight, use Trimmer M-363-Assy-1	
M-84-8C	Work Plate	M-84-8	Curved-Hemming use Trimmer M-363-Assy-3	
M-84-11C	Work Plate	M-84-11	Straight, use Trimmer M-363-Assy-1	
M-84-12C	Work Plate	M-84-12	Curved, use Trimmer M-363-Assy-1	
M-84-15C	Work Plate	M-84-15	Curved-Hemming use Trimmer M-363-Assy-3	
M-84-16C	Work Plate	M-84-16	Curved, use Trimmer M-363-Assy-1	
M-84-17C	Work Plate	M-84-17	Curved, use Trimmer M-363-Assy-1	
M-84-18C	Work Plate	M-84-18	Curved, use Trimmer M-363-Assy-1	
M-29-6	Work Plate Support	M-29-2	Sc. (2) $34\frac{7}{16}$	44
M-29-7	Work Plate Support	M-29-8	Sc. (2) $34\frac{3}{16}$	44

TRIMMER ASSEMBLIES

4 TOOTH



M-363-Assy-1

Used with regular length
Needle Plates, such as, A-70-17C

Includes:

M-363-1 U. Trimmer
M-364-1 L. Trimmer
M-152-1 Key
1 $\frac{3}{32}$ Washer
13 $\frac{3}{32}$ Screw
M-198-9 Plunger
3-#2 Screw

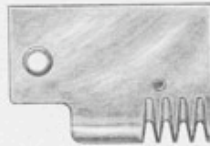

M-363-Assy-2

Used with medium length
Needle Plates, such as, A-70-38C

Includes:

M-363-2 U. Trimmer
M-364-1 L. Trimmer
M-152-1 Key
1 $\frac{3}{32}$ Washer
13 $\frac{3}{32}$ Screw
M-198-10 Plunger
3-#2 Screw

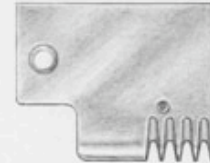

M-363-Assy-3

Used with short length
Needle Plates.

Includes:

M-363-3 U. Trimmer
M-364-1 L. Trimmer
M-152-1 Key
1 $\frac{3}{32}$ Washer
13 $\frac{3}{32}$ Screw
M-198-11 Plunger
5-#2 Screw

The above Trimmer Assemblies are used with Rocker Shaft Extensions M-367-1, 2, 3 and 4 depending on the L.C.H. Support Shim.

3 TOOTH



M-363-Assy-4

Used with regular length
Needle Plates, such as, A-70-17C

Includes:

M-363-4 U. Trimmer
M-364-2 L. Trimmer
M-152-1 Key
1 $\frac{3}{32}$ Washer (2)
13 $\frac{3}{32}$ Screw
M-198-14 Plunger
4-#2 Screw



M-363-Assy-5

Used with medium length
Needle Plates, such as, A-70-38C

Includes:

M-363-5 U. Trimmer
M-364-2 L. Trimmer
M-152-1 Key
1 $\frac{3}{32}$ Washer (2)
13 $\frac{3}{32}$ Screw
M-198-16 Plunger
3-#2 Screw



M-363-Assy-6

Used with short length
Needle Plates.

Includes:

M-363-6 U. Trimmer
M-364-2 L. Trimmer
M-152-1 Key
1 $\frac{3}{32}$ Washer (2)
13 $\frac{3}{32}$ Screw
M-198-11 Plunger
3-#2 Screw

The above Trimmer Assemblies are used with Rocker Shaft Extensions M-367-5, 6, 7 and 8 depending on L.C.H. Support Shim.

Use Wrench A-289-3 for Screws 3-#2, 4-#2, 5-#2.

MERROW®

From the library of: Diamond Needle Corp



THE
MERROW®
MACHINE COMPANY

240 DAY STREET
NEWINGTON, CT 06111
Tel. (203) 666-0109
Telex 994473 MERROW, NEWI

For worldwide markets, American made since 1838

Cutter Grinder

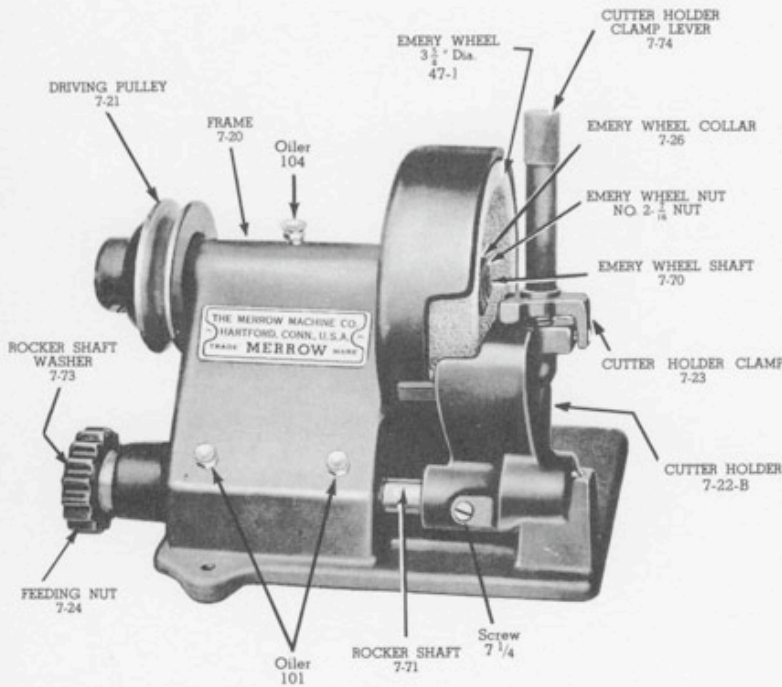

Part No.

- 7-20-A Cutter Grinder Complete
- 7-21 Frame
- 7-21 Driving Pulley
- 7-22-B Driving Pulley Screw 5/4 (2)
- 7-22-B Cutter Holder (including Pin 36-15)
- 7-23 Cutter Holder Screw 7/4
- 7-23 Cutter Holder Clamp
- 7-24 Cutter Holder Clamp Spring 27-14
- 7-24 Feeding Nut
- 7-26 Emery Wheel Collar (2)
- 7-70 Emery Wheel Shaft
- 7-71 Rocker Shaft
- 7-72 Rocker Shaft Collar
- 7-73 Rocker Shaft Washer
- 7-73 Rocker Shaft Washer Screw 6-3/16
- 7-74 Cutter Holder Clamp Lever
- 7-76 Friction Leather
- 7-76 Friction Leather Screw 1-3/8
- 47-1 Emery Wheel 3-5/8" Diameter
- Emery Wheel Nut 2-7/16
- Oiler 101 (lubricates rocker shaft) (2)
- Oiler 104 (lubricates emery wheel shaft)

Thread Stand

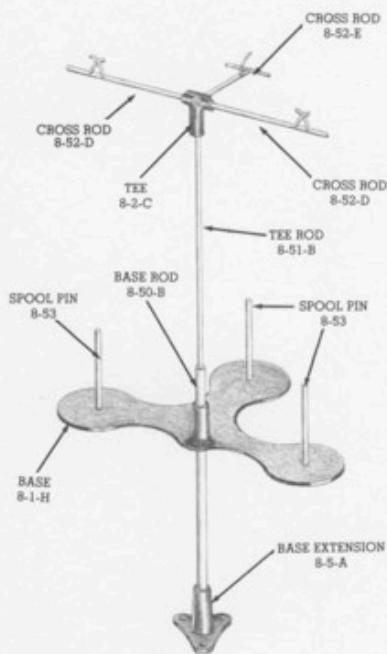

	TWO-THREAD THREAD STAND COMPLETE	THREE-THREAD THREAD STAND COMPLETE	FOUR-THREAD THREAD STAND COMPLETE
Base	8-1-G	8-1-H	8-1-G (2)
Screw 1 1/4			
Screw 20 1/4			
Tee	8-2-B	8-2-C	8-2-B
Screw (4) 20 3/4			
Base Extension	8-5-A	8-5-A	8-5-A
Screw 35 1/4			
Base Rod	8-50-B	8-50-B	8-50-C
Tee Rod	8-51-B	8-51-B	8-51-B
Cross Rod	8-52-D (2)	8-52-D (2)	8-52-H (2)
Cross Rod		8-52-E	
Spool Pin	8-53 (2)	8-53 (3)	8-53 (2)
Spool Pin			8-53-A (2)

Also available: Six-Thread Thread Stand