

HIGHLEAD

GC22618

CYLINDER-BED UNISON FEED SEWING MACHINE

Instruction Manual
Parts Catalog

SHANGHAI HUIGONG NO.3 SEWING MACHINE FACTORY

CONTENTS

INSTRUCTION MANUAL

1、 PRECAUTIONS BEFORE STARTING OPERATION.....	1
2、 SPECIFICATIONS	1
3、 PRECAUTIONS FOR SEWING OPERATE	2
4、 NEEDLE	3
5、 WINDING THE LOWER THREAD	3
6、 ADJUSTING OF THE BOBBIN WINDER	4
7、 REMOVING AND INSERTING THE BOBBIN	4
8、 THREADING	4
9、 ADJUSTING OF THREAD TENSION	5
10、 ADJUSTING THE PRESSURE OF PRESSER FOOT	6
11、 STITCH LENGTH & REVERSING LEVER	6
12、 ADJUSTING THE LIFT OF THE ALTERNATING PRESSER FOOT	6
13、 RE-SET THE SAFETY CLUTCH MECHANISM	7
14、 ADJUSTING THE HEIGHT OF THE FEED DOG	7
15、 RELATIVE POSITION OF THE FEED DOG TO NEEDLE PLATE	7
16、 ADJUSTING THE HEIGHT OF THE NEEDLE BAR	8
17、 ADJUSTING THE HEIGHT OF THE PRESSER FOOT	8
18、 TIMING OF THE VIBRATING PRESSER FOOT	9
19、 ADJUSTING THE THREAD TAKE-UP SPRING	9

CATALOG

A、 ARM BED AND ITS ACCESSORIES	10
B、 TAKE-UP THREAD AND ARM SHAFT MECHANISM	13
C、 ROTATING HOOK SHAFT MECHANISM	15
D、 FEEDING AND FEED LIFTING MECHANISM	18
E、 STITCH REGULATOR MECHANISM	20
F、 NEEDLE BAR FEEDING MECHANISM	22
G、 PRESSER FOOT MECHANISM	25
H、 ACCESSORIES	27

1、 PRECAUTIONS BEFORE STARTING OPERATION

1) Safety precautions

(1) When turning the power on, keep your hands and fingers away from the area around/under the needle and the area around the pulley.

(2) Power must be turned off when the machine is not in use, or when the operator leaves the seat.

(3) Power must be turned off when tilting the machine head, installing or removing the “V” belt, adjusting the machine, or when replacing.

(4) Avoid placing fingers, hairs, bars etc., near the pulley, “V” belt, bobbin winder pulley, or motor when the machine is in operation.

(5) Do not insert fingers into the thread take-up cover, under/around the needle, or pulley when the machine is in operation.

(6) If a belt cover, finger guard, eye guard are installed, do not operate the machine without these safety devices.

2) Precautions before starting operation

(1) If the machine’s oil pan has an oil sump, never operate the machine before filling it.

(2) If the machine is lubricated by a drop oiled (consider revising), never operate the machine before lubricating.

(3) When a new sewing machine is first turned on, verify the rotational direction of the pulley with the power on. (The pulley should rotate counterclockwise when viewed from the pulley)

(4) Verify the voltage and (single or three) phase with those given on the machine nameplate.

3) Precautions for operating conditions

(1) Avoid using the machine at abnormally high temperatures (35°C or higher) or low temperatures (5°C or lower) .

(2) Avoid using the machine in dusty conditions.

2、 SPECIFICATIONS

Max. Sewing Speed		2200rpm
Max. Stitch Length		5mm
Thread Take-up Lever Stroke		61.5mm
Needle Bar Stroke		33.4mm
Presser Foot Stroke	By Hand	8mm
	By Knee	14mm
Alternating Movement	Lifting Presser Foot	4.3mm
Needle		DP×17 22#
Rotating Hook		KRT31-11SG
Lubrication System		Manual
Electric Machinery		1400 rpm 370W

3. PRECAUTIONS FOR SEWING OPERATE

1) Cleaning the machine

Before leaving the factory, the machine parts are coated with rust-preventive grease, which may be hardened and contaminated by dust during storage and shipment. This grease must be removed with gasoline.

2) Examination

Though every machine is confirmed by strict inspection and test before leaving the factory, the machine parts may be loosen or deformed after long distance transportation with jolt. A thorough examination must be performed after cleaning the machine. Turn the balance wheel to see if there is running obstruction, parts collision, uneven resistance or abnormal noise. If these exist, adjustment must be made accordingly before run-in operation.

3) Lubrication (Fig.1、 Fig.2、 Fig.3、 Fig.4)

When a new sewing machine is first operated, or when a sewing machine is operated which is out of use for long period of time, it will be necessary to oil through the oil holes after removing the rubber plugs shown below.

For oil, Use white spindle oil

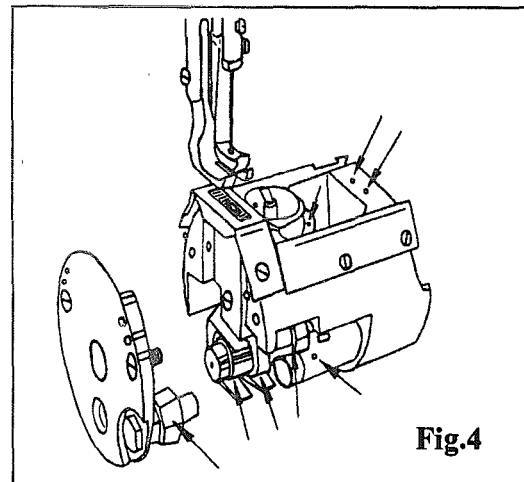
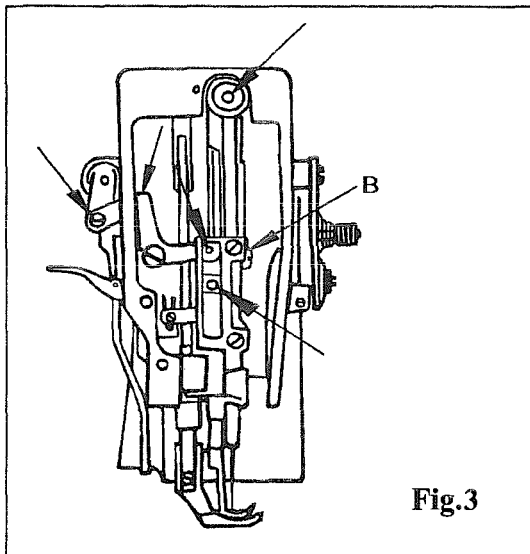
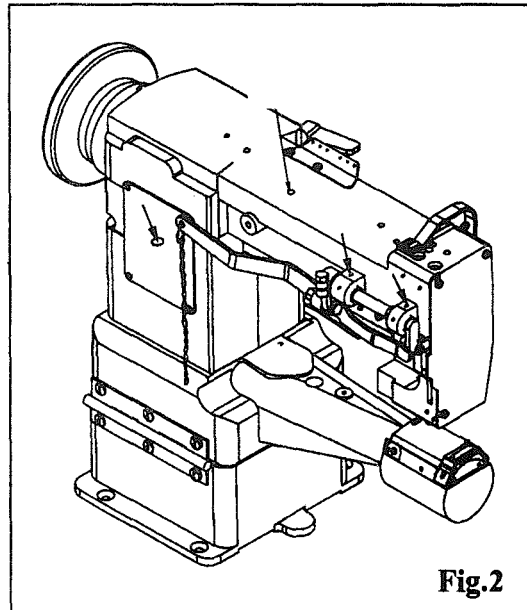
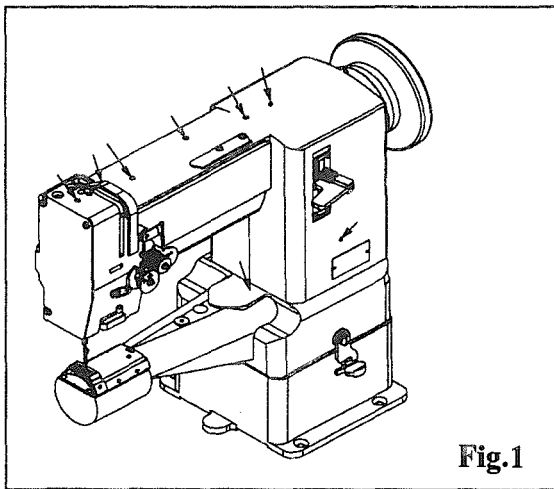

4) Broken-in

It is imperative that for the first several weeks of operation the max. Speed is held at less than 1600rpm in order to allow the parts to become properly broken-in.

4、 NEEDLE (Fig.5)

Use DP×17 #22. The size of the needle to be used should be determined by the size of the thread, which must pass freely through the eye of the needle.

1) Removing the needle bar to the highest position;

2) Loosen the needle screw, insert the needle up to the bottom of needle clamp. Keep the long groove side of needle forward the left.

3) Tighten the screw.

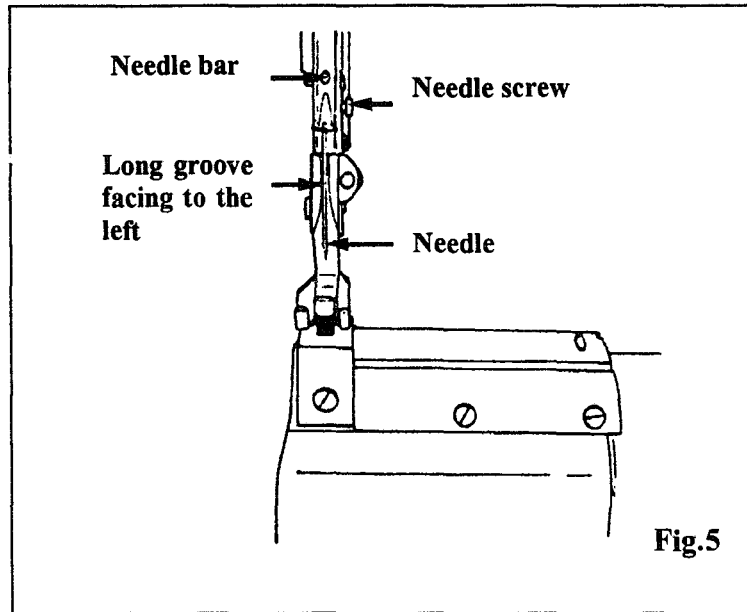

5、 WINDING THE LOWER THREAD (Fig.6)

1) Push a bobbin on the bobbin winder spindle (3) as far as it will go.

2) Pass the thread from the thread stand downward through the eye (1) in the tension bracket, then between and around the back of the tension disc (2).

3) Bring the thread forward toward the bobbin and wind from below in clockwise direction several times around the bobbin.

4) Push the lever (4) toward other side so that the pulley and V belt will engage and then start the machine.

5) The pulley will automatically be free from the belt and stopped after the bobbin is filled with thread.

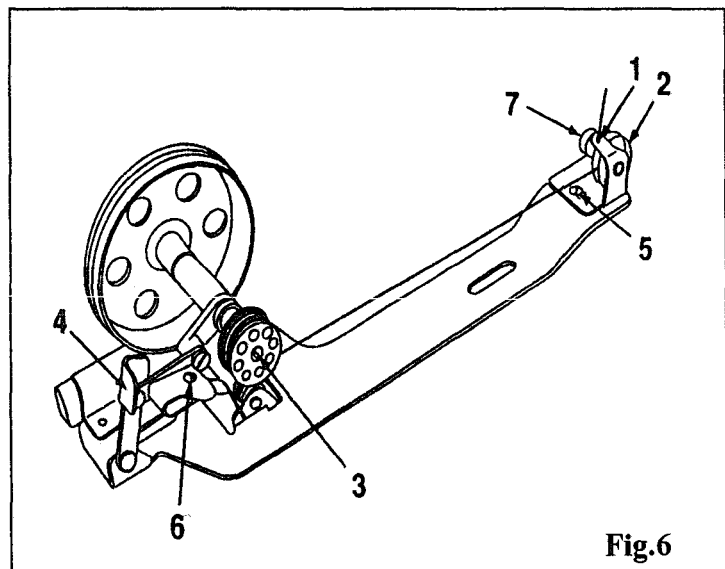

6、 ADJUSTING THE BOBBIN WINDER (Fig.6)

1) In case of uneven winding

Loosen the screw (5) in the tension bracket and move the bracket to the right or to the left as may be required.

2) Winding amount of thread

Adjustment screw (6) can be turned in or out to increase or to decrease the amount of thread wound on the bobbin.

3) Winding strength

Strength of the winding can be adjusted with the nut (7)

7、 REMOVING AND INSERTING THE BOBBIN (Fig.7)

1) Take out the bobbin

Open the cover and take out the bobbin.

2) Install the bobbin

Replace the bobbin to the bobbin case; pull the thread to the left.

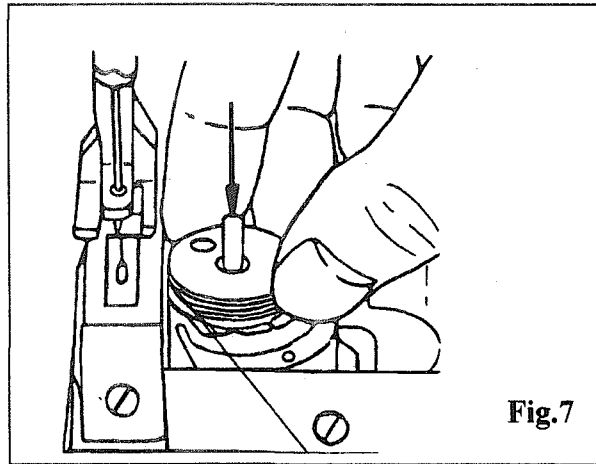

8、 THREADING (Fig.8)

Raise the needle bar to its highest position and thread the upper thread in the following order.

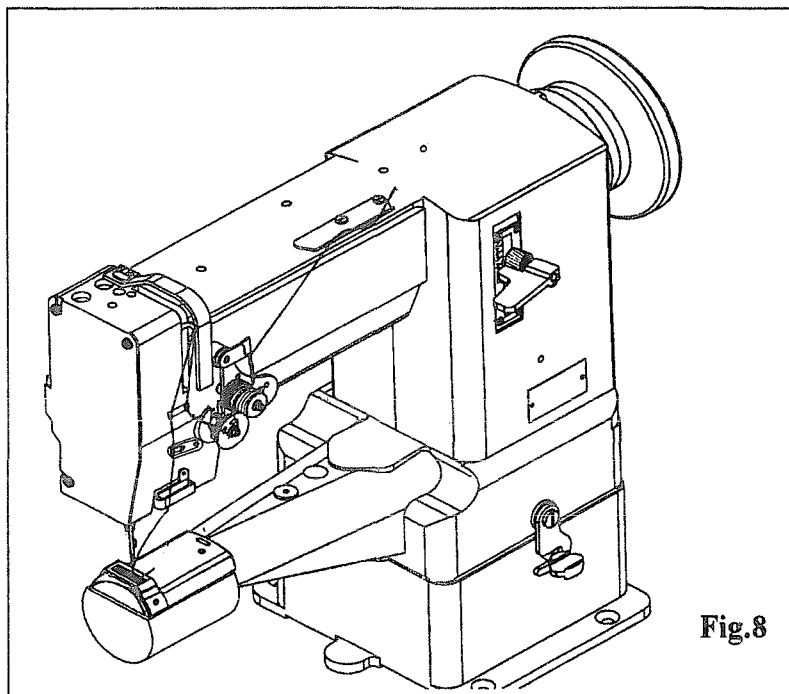

9. ADJUSTING OF THREAD TENSION (Fig.9)

For ordinary stitching, the tension of the upper and the lower threads should be equal.

1) Tension of upper thread (Fig.10)

Before adjusting the tension of the upper thread, it should be certain that the presser foot is let down but not in other position. To adjust tension, turn serrated nut on tension device to the right to increase tension and to the left if you desire to decrease it.

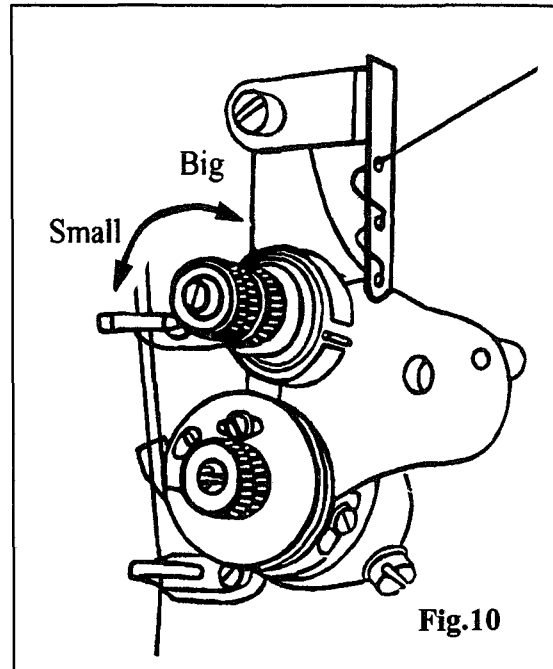
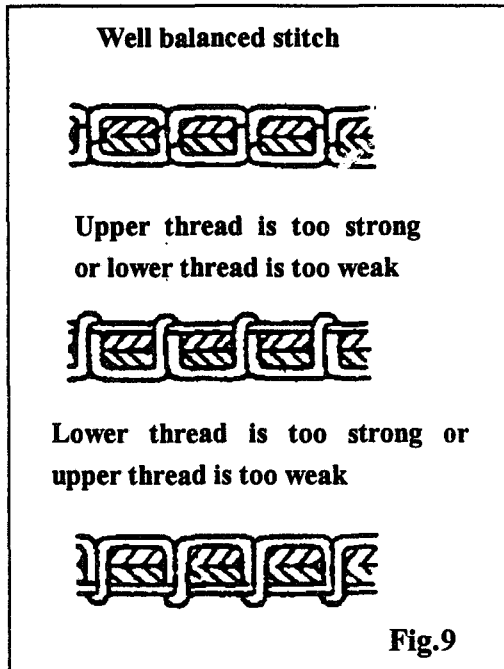

2) Tension of the lower thread (Fig.11)

Turning the larger screw (A) to the right (clockwise) will increase the thread tension, while turning it to the left (counter-clockwise) will decrease it.

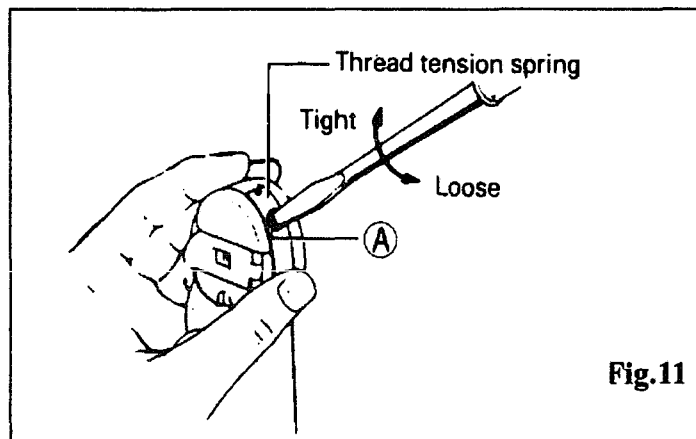

10. ADJUSTING THE PRESSURE OF PRESSER FOOT (Fig.12)

Pressure of the presser foot can be adjusted by turning the pressure regulating thumb screw (A)
To increase the pressure, turn the screw to the right and to left if you decrease the pressure.

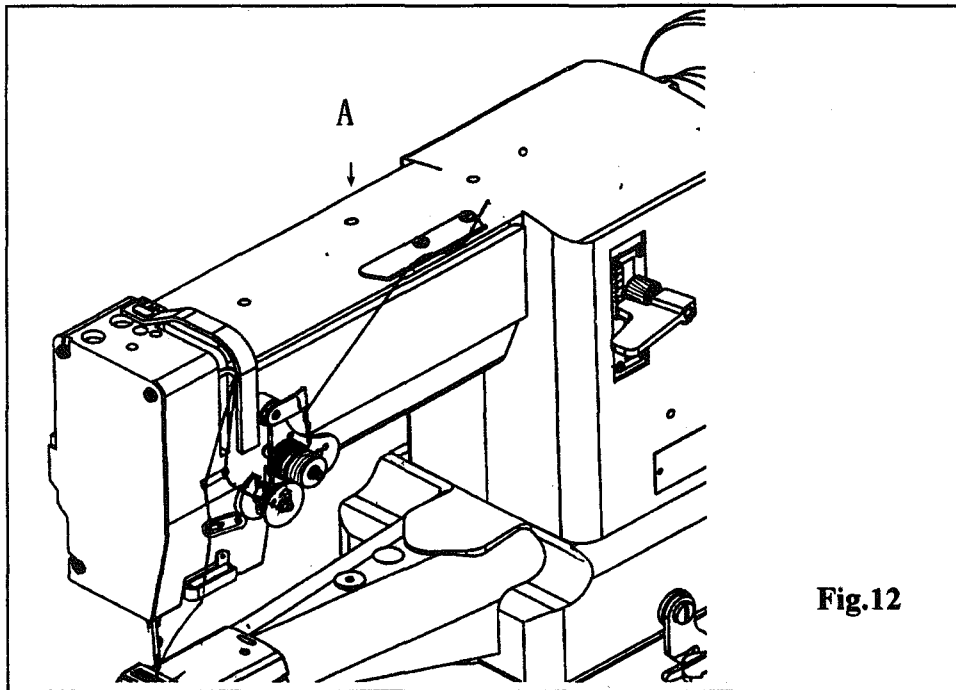

Fig.12

11. STITCH LENGTH & REVERSING LEVER (Fig.13)

Adjusting the stitch adjustment bar can set stitch length

For desired stitch length, push the stitch adjustment bar downward.

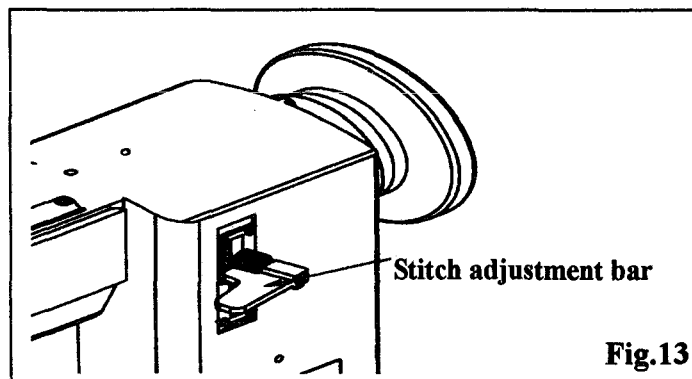

Fig.13

12. ADJUSTING THE LIFT OF THE ALTERNATING PRESSER FOOT (Fig.14)

To alter lift, loosen the wing nut (1) and move the link and stud assembly along the slot-move up to raise the feeding presser foot and push down to lower this foot. Tight wing nut upon completion of adjustment.

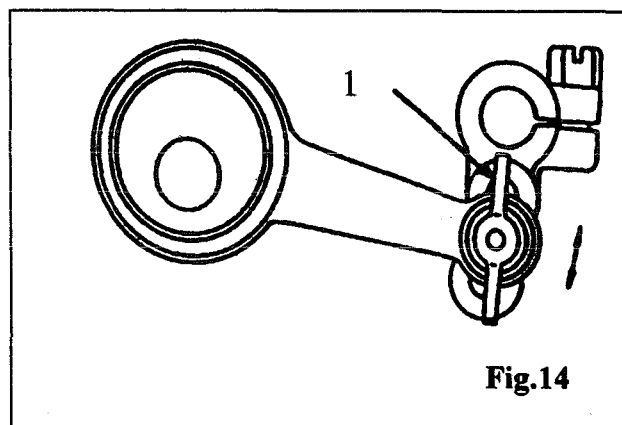

Fig.14

13、 RE-SET THE SAFETY CLUTCH MECHANISM (Fig.15)

- 1) Removing any foreign matter may have lodged itself in the hook. Do not use any sharp-edged tools.
- 2) Depress button (D), turn the pulley clockwise until the locking mechanism re-engages.

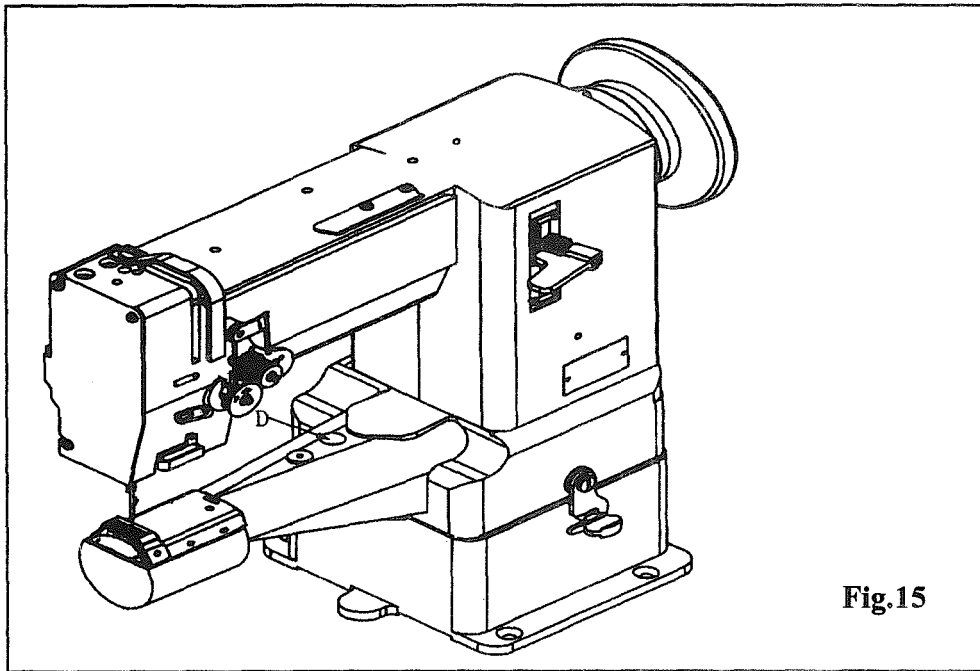

Fig.15

14、 ADJUSTING THE HEIGHT OF THE FEED DOG (Fig.16)

The max. Height of the feed dog from the surface to the needle plate is normally 1mm.

To adjust this height:

- 1) Set the stitch length at minimum.
- 2) Turn the pulley so as to raise the feed dog to it highest position.
- 3) Take out cover (1), Loosen the screw (2), adjust the height of the feed dog.
- 4) Tighten the screw (2) after adjustment.

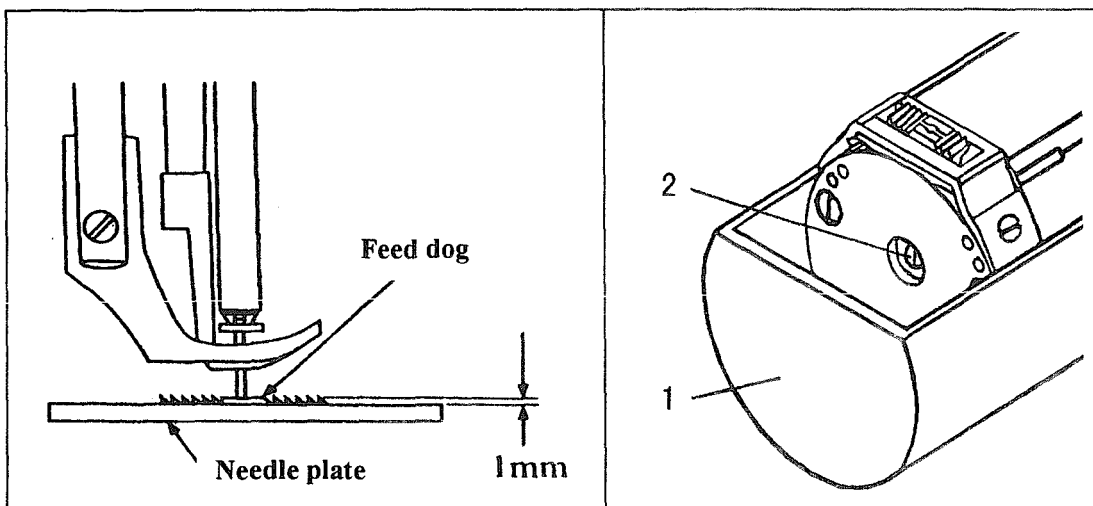

Fig.16

15. RELATIVE POSITION OF THE FEED DOG TO NEEDLE PLATE

(Fig.17)

- 1) Set the stitch length at minimum.
- 2) Turn the pulley so as to raise the feed dog to its highest point.
- 3) Lay down the machine head toward the other side, loosen the screw (E).
- 4) Adjust the needle plate to the center of the needle hole on the feed dog.
- 5) Tighten the screw.

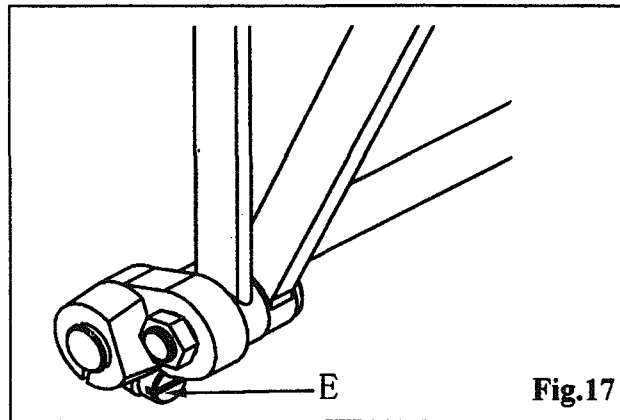

Fig.17

16. ADJUSTING THE HEIGHT OF THE NEEDLE BAR (Fig.18)

When the needle bar is at its highest position, normally the measurement between the surface of the needle plate and the upper end of the needle eye is 22.3mm. To adjust this, loosen screw (B) (Fig.3), and raise or lower the needle bar as may be required. Then tighten the screw.

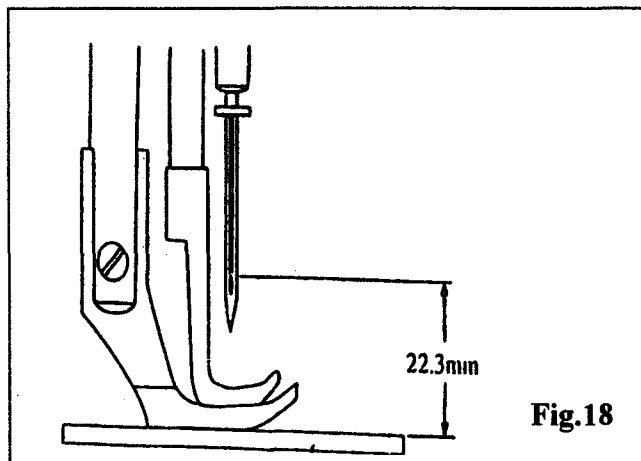

Fig.18

17. ADJUSTING THE HEIGHT OF THE PRESSER FOOT (Fig.19)

1) Adjustment by the presser bar lifter

Loosen the screw (1), raise the presser bar lifter and loosen the setscrew (2), move the lifting presser foot up or down as may be required so as to get the correct height and tighten screws.

2) Adjusting the lift of alternating presser foot

If the height of the lifting presser foot changes, the momentums of the lifting and vibrating presser foot vary, thus the height of the vibrating presser foot must be adjusted. Lower the presser bar lifter, holding the vibrating presser foot and loosen the screw (3) and move the presser foot up or down as may be required. After setting the position, tighten the screw.

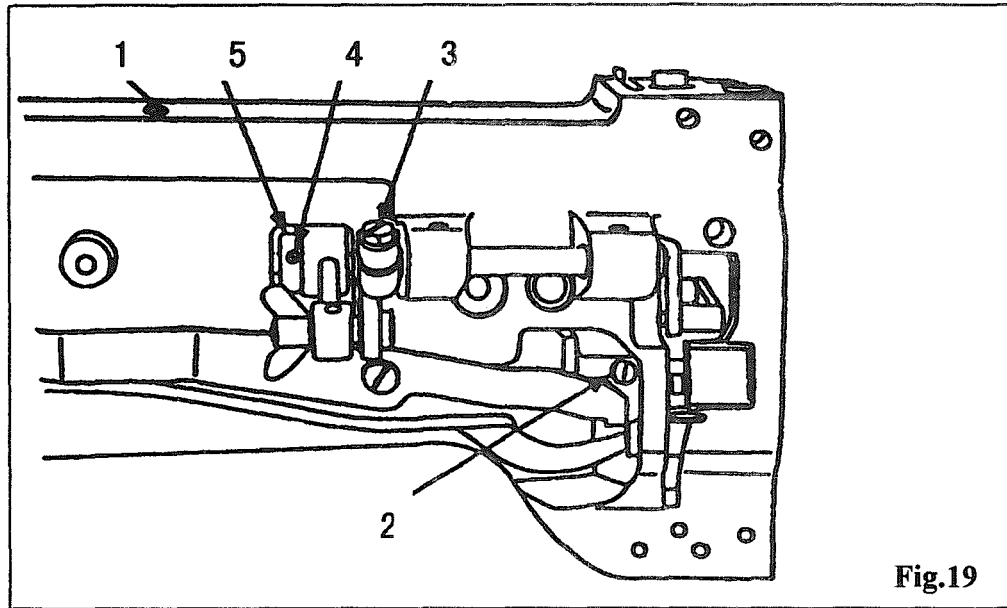

18. TIMING OF THE VIBRATING PRESSER FOOT (Fig.19)

This is the normal timing when turn the pulley toward you, after lowering the presser bar lifter, the vibrating presser foot should reach the feed dog earlier than the needle eye comes to, and when the needle raises, the vibrating presser foot should leave the feed dog after the needle eye has left the feed dog. This is due the reason that the vibrating presser foot must tightly hold the goods while the needle is passing the goods for avoiding irregular stitches. To adjust this, set the lift of the alternating presser feet to equal, loosen the two screws (4) and adjust the rotating position of the cam faster or slower as may be desired, and tighten the screws.

19. ADJUSTING THE THREAD TAKE-UP SPRING (Fig.20)

Normally, the thread take-up spring (1) should hold slack of the upper thread until the needle reaches to the goods, and it should pause while raising of the needle and passing the upper thread through the bobbin case.

1) For more control action on the thread

Loosen the stop screw (2), move the stop (3) to the right (for less action, move to left). Tighten the screw.

2) To adjust the tension spring

Loosen the nut (4) and screw (5), turn the tension stud (6) slightly to the left to strengthen the tension (to lighten the tension, turn to the right) with a screw driver. Tighten the screw and nut upon completion of adjustment.

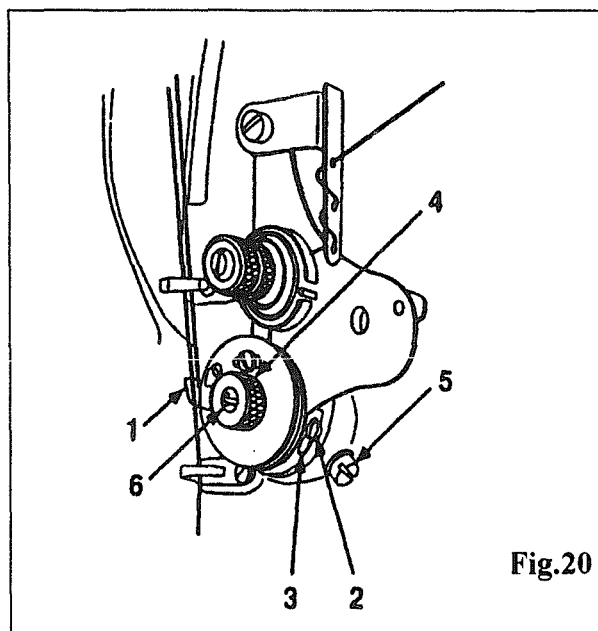

A. ARM BED AND ITS ACCESSORIES

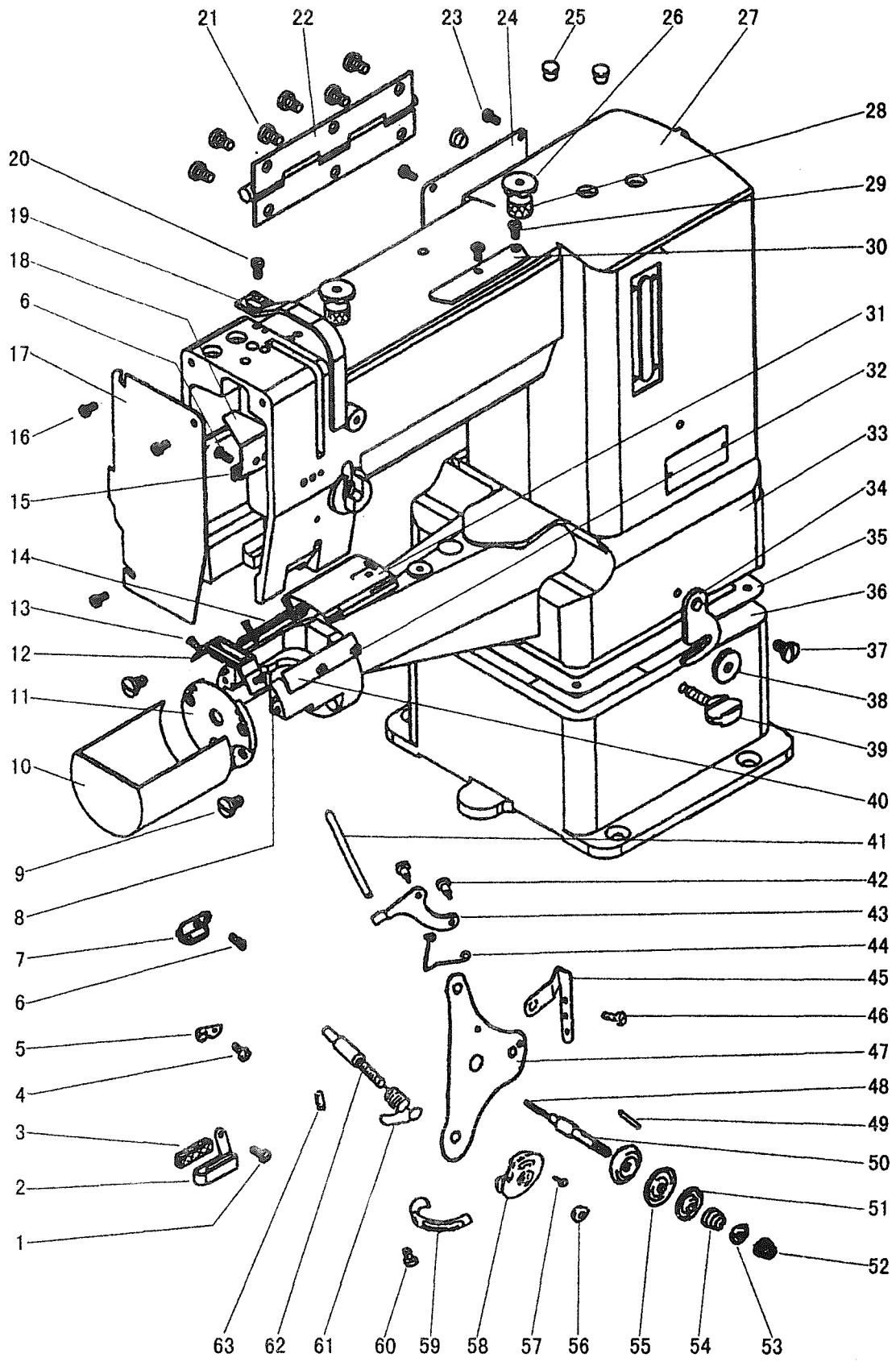

From the library of: Diamond Needle Corp

A. ARM BED AND ITS ACCESSORIES

Fig. No.	Part No.	Description	Pcs.	Remarks
A01	HA500C2070	Screw	1	SM9/64 (40) ×5
A02	H3108B0691	Thread guide	1	
A03	H3108B0692	Felt	1	
A04	HA106B0676	Screw	1	SM9/64 (40) ×6
A05	HA106B0675	Thread guide	1	
A06	H2400B2080	Screw	2	SM3/16 (28) ×13
A07	H2400B2070	Thread guide	1	
A08	H605030100	Stop plate pin	2	GB/T119.2 3×10
A09	H4100B2260	Screw	2	SM3/16 (28) ×10
A10	H4122B0068	Cover	1	
A11	H4100B2240	Stop plate	1	
A12	H4100B2250	Needle plate	1	
A13	H4100B2180	Screw	2	SM9/64 (40) ×8.2
A14	H4100B2220	Needle guide plate (right)	1	
A15	H2400B2060	Plate for oil guard	1	
A16	HA300B2170	Screw	3	
A17	H3106B0671	Face plate	1	
A18	H2400B2050	Oil guard	1	
A19	H3100B2060	Thread take-up guard	1	
A20	HA300B2160	Screw	1	SM11/64 (40) ×10
A21	H4100B2110	Screw	6	SM1/4 (24) ×9.8
A22	H4100B2100	Hinge	1	
A23	HA300B2170	Arm side cover screw	4	
A24	H4100B2150	Arm side cover	1	
A25	HA307B0674	Rubber plug	3	φ 11.8
A26	H2400J2010	Oil wick	2	
A27	H4105B0022	Arm	1	
A28	H2400J2020	Oil cap	2	
A29	HA700B2060	Screw	2	SM11/64 (40) ×8
A30	H2400B2100	Thread guide	1	
A31	H4123B0069	Slide plate	1	
A32	H4100B2180	Screw	4	SM9/64 (40) ×8.2
A33	H4106B0662	Arm bed	1	
A34	H4100B2060	Link plate	1	
A35	H4100B2050	Oil reservoir	1	
A36	H4107B0672	Supporter	1	
A37	H4100B2070	Screw	1	SM1/4 (24) ×5.7
A38	H4100B2090	Washer	1	
A39	H4100B2080	Screw	1	SM1/4 (24) ×20
A40	H4100B2210	Needle guide plate (left)	1	
A41	H3100G2230	Thread tension releasing pin	1	
A42	H2504C6510	Screw	2	SM9/64 (40) ×3
A43	H3111B0704	Tension releasing plate	1	

A. ARM BED AND ITS ACCESSORIES

Fig. No.	Part No.	Description	Pcs.	Remarks
A44	H3111B0705	Tension releasing spring	1	
A45	H3100B2070	Three-hole thread guide	1	
A46	HA7311C606	Screw	1	SM11/64 (40) ×12
A47	H31611B111	Mounting plate	1	
A48	H2504C0121	Thread tension releasing pin	1	
A49	H31611B211	Tension bracket pin	1	
A50	H2504C0013	Screw	1	SM11/64 (32) ×7
A51	H2504C0657	Thread tension disk	1	
A52	HA310B0701	Thumb nut	1	
A53	HA115B7010	Stop disk	1	
A54	HA607B0068	Thread tension spring	1	
A55	H2504C0656	Thread tension disk	2	
A56	H2504C0658	Thumb nut	1	SM1/4 (40) ×4.5
A57	H3111B0703	Screw	1	SM3/32 (56) ×6
A58	H2504C0654	Thread controller disc	1	
A59	H3221B6819	Spring stop	1	
A60	H32481BC21	Screw	1	SM9/64 (40) ×6
A61	H3111B0702	Thread take-up spring	1	
A62	H31611B311	Screw	1	SM1/4 (40) ×10.5
A63	HA300B2080	Screw	1	SM15/64 (28) ×6.8

B. TAKE-UP THREAD AND ARM SHAFT MECHANISM

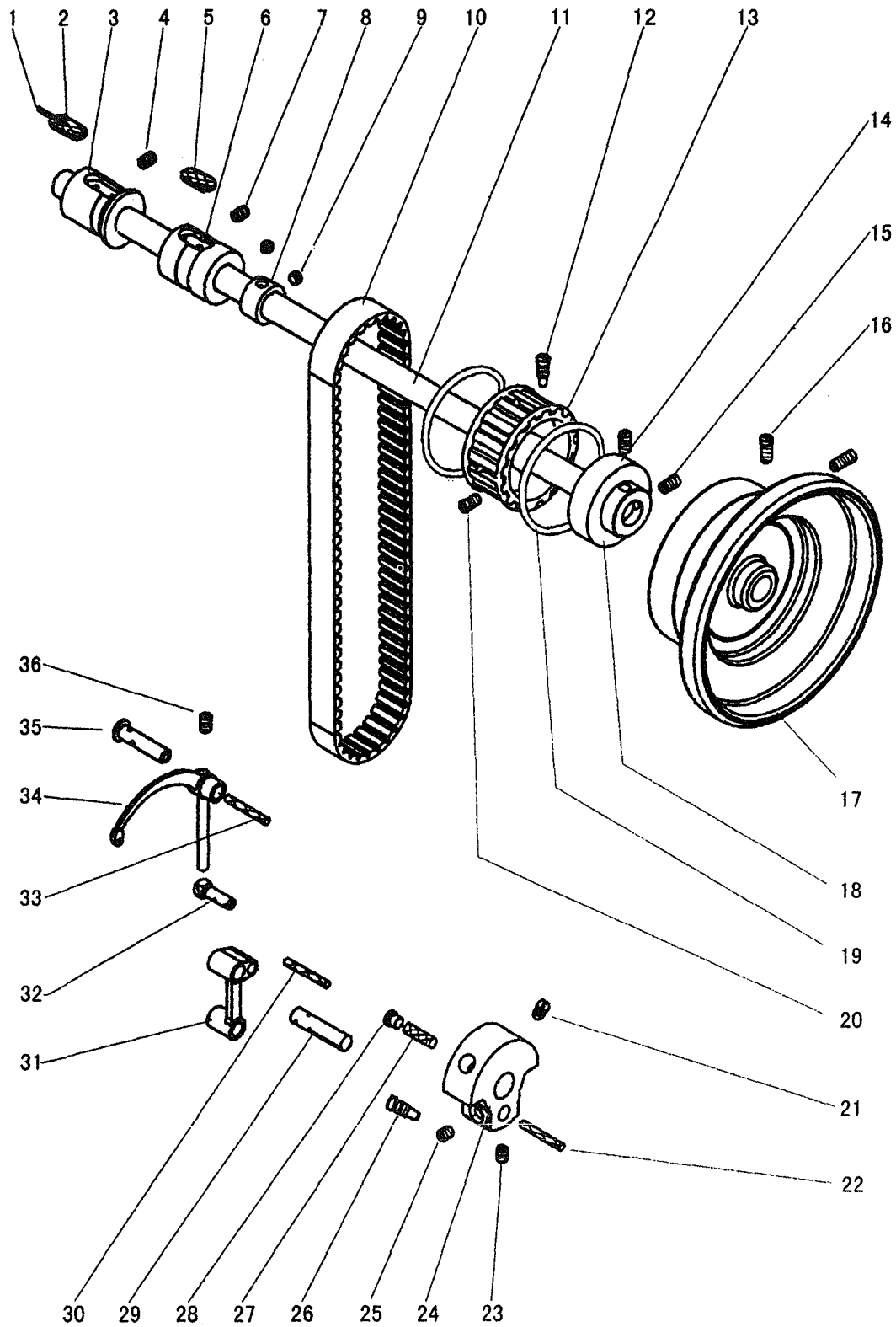

B. TAKE-UP THREAD AND ARM SHAFT MECHANISM

Fig. No.	Part No.	Description	Pcs.	Remarks
B01	H2009B0742	Felt	1	
B02	H2009B0743	Felt	1	
B03	H31133B104	Arm shaft bushing (left)	1	
B04	HA100C2020	Screw	1	SM15/64 (28) ×10
B05	H31122B104	Felt	1	
B06	H4105C0661	Arm shaft bushing (middle)	1	
B07	HA100C2020	Screw	2	SM15/64 (28) ×10
B08	HA108G0661	Collar for arm shaft	1	
B09	HA105D0662	Screw	2	SM1/4 (40) ×4
B10	H3200C2030	Belt	1	
B11	H4100C2030	Arm shaft	1	
B12	HA100F2130	Screw	1	SM15/64 (28) ×8
B13	H3205C1021	Pulley	1	
B14	H3205J0662	Bear	1	
B15	HA113F0684	Screw	2	SM15/64 (28) ×8.5
B16	HA110D0672	Screw	2	SM15/64 (28) ×12
B17	H4100C2040	Balance wheel	1	
B18	H3205J0661	Arm shaft bushing(right)	1	
B19	H3205C0661	Spring washer	2	
B20	HA113F0684	Screw	1	SM15/64 (28) ×8.5
B21	HA100C2060	Screw	1	SM9/32 (28) ×13
B22	H3100C2080	Oil wick	1	
B23	HA105D0662	Screw	1	SM1/4 (40) ×4
B24	H4100C2050	Needle bar crank	1	
B25	HA108C0663	Screw	1	SM1/4 (40) ×7
B26	HA100C2070	Screw	1	SM9/32 (28) ×10
B27	H3200C2120	Oil wick	1	
B28	H3200C2130	Oil packing stop screw	1	
B29	H3100C2070	Hinge pin	1	
B30	H24211D405	Oil wick	1	
B31	H3100C2060	Thread take-up pin	1	
B32	H2405D1112	Driving stud	1	
B33	H2405D1122	Oil wick	1	
B34	H2405D1111	Thread take-up lever	1	
B35	H2405D1121	Hinge pin	1	
B36	HA110D0672	Screw	1	SM15/64 (28) ×12

C. ROTATING HOOK SHAFT MECHANISM

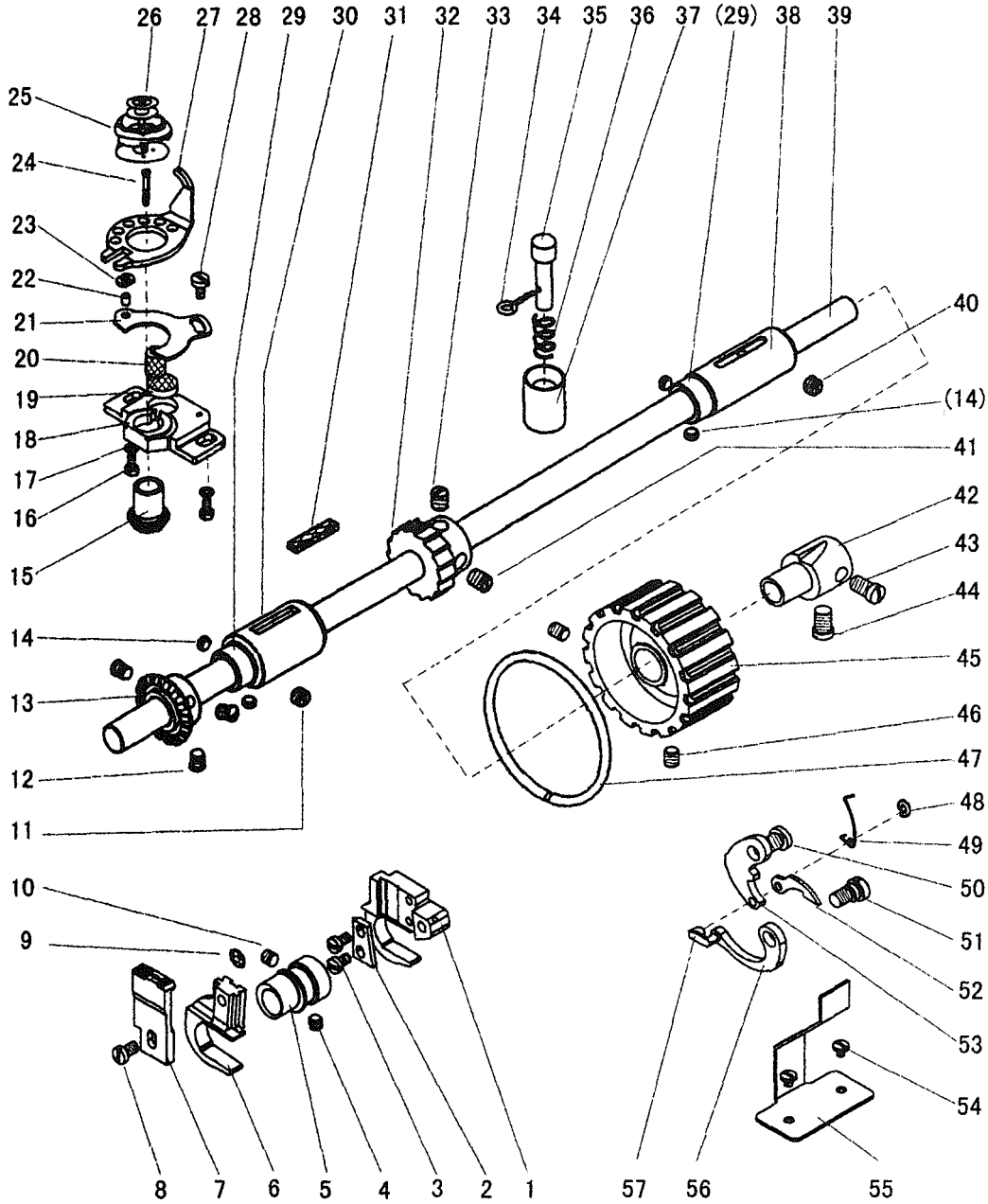

From the library of: Diamond Needle Corp

C. ROTATING HOOK SHAFT MECHANISM

Fig. No.	Part No.	Description	Pcs.	Remarks
C01	H41111E104	Feed lifting rock shaft crank	1	
C02	H4104E0653	Slide block for crank	1	
C03	HA106B0676	Screw	2	SM9/64 (40) ×6
C04	H4104C0652	Screw	1	SM13/64 (32) ×5
C05	H4104C0651	Feed eccentric	1	
C06	H4104E0652	Feed rock shaft crank	1	
C07	H41111E304	Feed dog	1	
C08	H41111E404	Screw	1	SM11/64 (32) ×7
C09	H41111E204	Felt	1	
C10	H4104C0653	Screw	1	SM13/64 (32) ×4.5
C11	H4100D2080	Screw	1	SM1/4 (24) ×4.5
C12	H4108D0682	Screw	3	SM13/64 (32) ×6
C13	H4108D0681	Bevel gear for hook shaft	1	
C14	H4105D0652	Screw	4	SM13/64 (32) ×3.5
C15	H4100D2060	Bevel gear for hook shaft	1	
C16	H4100D2140	Screw	2	SM3/16 (28) ×11
C17	H005001050	Washer	2	GB/T97.1 5
C18	H41611D116	Rotating hook bracket	1	
C19	H41611D316	Felt	1	
C20	H41611D216	Felt	1	
C21	H410269D16	Guide plate	1	
C22	H410270D16	Guide plate pin	1	
C23	H41622D216	Guide plate slide block	1	
C24	H4100D2180	Screw	1	SM9/64 (40) ×10
C25	H4114D0069	Rotating hook	1	
C26	H2800I2020	Bobbin	1	
C27	H4100D2120	Rotating position guide	1	
C28	H2204C0651	Screw	1	SM9/64 (40) ×5
C29	H4105D0651	Collar for hook shaft	2	
C30	H4100D2070	Hook shaft bushing (left)	1	
C31	H4100D2090	Felt	1	
C32	H4106D0661	Ratchet wheel	1	
C33	HA108C0663	Screw	1	SM1/4 (40) ×7
C34	H601016100	Safe clutch shaft pin	1	GB/T91 1.6×10
C35	H4107D0673	Safe clutch shaft	1	
C36	H4107D0672	Safe clutch spring	1	
C37	H4107D0671	Safe clutch bushing	1	
C38	H4100D2100	Hook shaft bushing(right)	1	
C39	H4100D2010	Rotating hook shaft	1	
C40	H4100D2080	Screw	1	SM1/4 (24) ×4.5
C41	H4106D0662	Screw	1	SM1/4 (40) ×8
C42	H4119D0717	Shaft for pulley	1	
C43	HA104F0654	Screw	1	SM15/64 (28) ×10

C. ROTATING HOOK SHAFT MECHANISM

Fig. No.	Part No.	Description	Pcs.	Remarks
C44	H4721D8001	Screw	1	SM15/64 (28) ×8.5
C45	H4722D8001	Pulley	1	
C46	H4723D8001	Screw	2	SM15/64 (28) ×4.5
C47	H3205C0661	Spring washer	1	
C48	H007013025	E-type ring	1	GB/T896 2.5
C49	H4716D8001	Spring for pulley	1	
C50	H4718D8001	Pin	1	
C51	H4714D8001	Pin	1	
C52	H4717D8001	Lever for pulley	1	
C53	H4719D8001	Short lever for pulley	1	
C54	HA106B0676	Screw	2	SM9/64 (40) ×6
C55	H4100D2170	Plate for pulley	1	
C56	H4713D8001	Long lever for pulley	1	
C57	H4715D8001	Link pin	1	

D. FEEDING AND FEED LIFTING MECHANISM

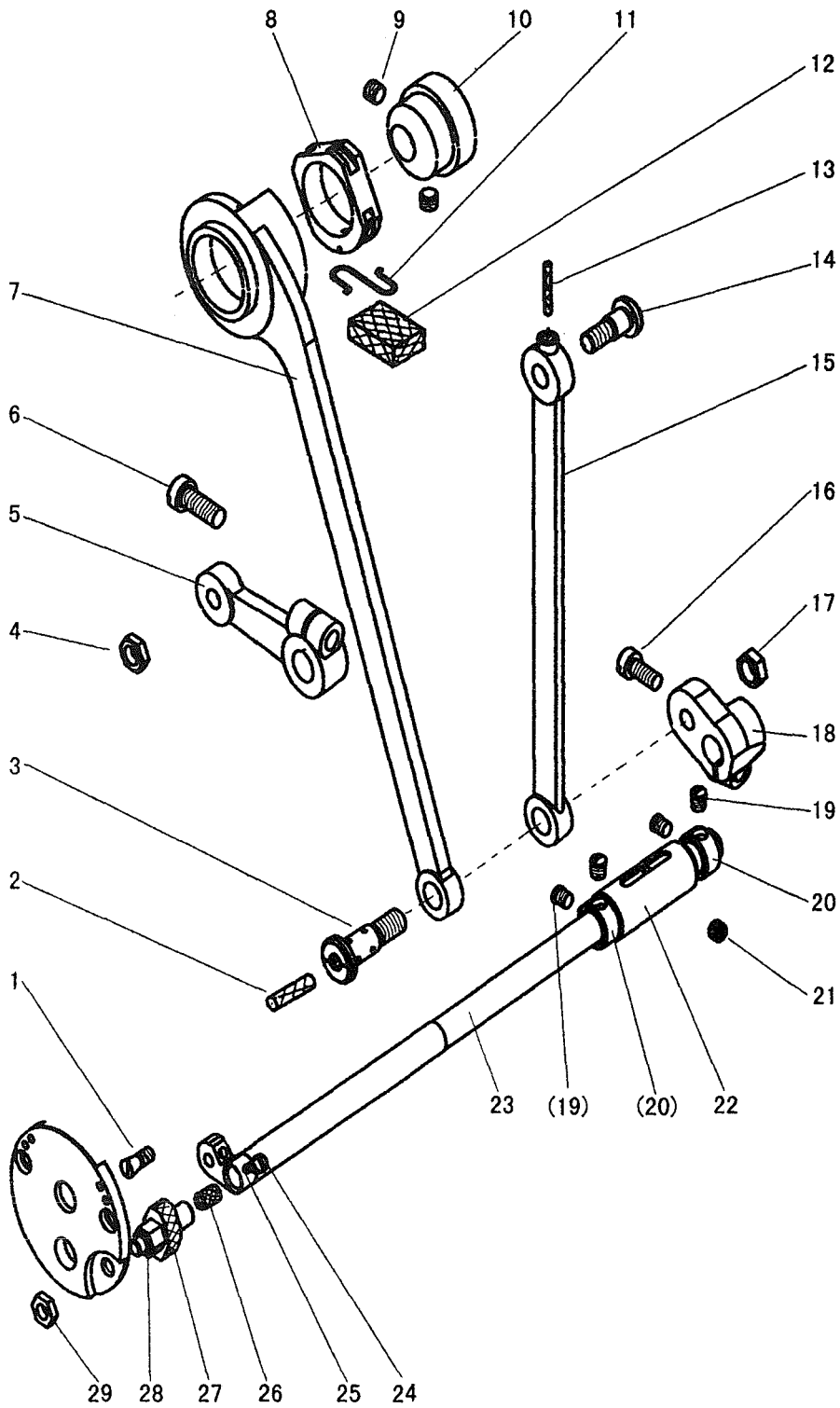

From the library of: Diamond Needle Corp

D. FEEDING AND FEED LIFTING MECHANISM

Fig. No.	Part No.	Description	Pcs.	Remarks
D01	H4100E2020	Screw	1	SM3/16 (28) ×6
D02	H41511E212	Oil wick	1	
D03	H41511E112	Pin	1	
D04	H4112E0699	Nut	1	SM17/64 (32) ×3.5
D05	H4112E0697	Crank for feed lifting shaft	1	
D06	H4112E0698	Screw	1	SM17/64 (32) ×17.5
D07	H4112E0691	Crank rock for feed shaft	1	
D08	H41611E113	Feeding slide block	1	
D09	HA108C0662	Screw	2	SM1/4 (40) ×6
D10	H41612E113	Eccentric wheel	1	
D11	H20111C106	Felt clip	1	
D12	H41611E213	Felt	1	
D13	H41552E212	Oil wick	1	
D14	H4112E0696	Pin	1	
D15	H41552E112	Crank rock for feed lifting	1	
D16	H4112E0693	Screw	1	SM7/32 (32) ×12.5
D17	H4112E0694	Nut	1	SM5/16 (20) ×4.5
D18	H4112E0692	Feed link crank	1	
D19	H4108D0682	Screw	4	SM13/64 (32) ×6
D20	H4105D0651	Collar for hook shaft	2	
D21	H4100D2080	Screw	1	SM1/4 (24) ×4.5
D22	H4100E2050	Feed rock shaft bushing	1	
D23	H4106E0661	Feed rock shaft	1	
D24	H2400I2070	Screw	1	SM9/64 (40) ×6
D25	H4106E0662	Set screw pin	1	
D26	H4106E0663	Oil wick	1	
D27	H4111E0682	Felt	1	
D28	H4111E0681	Pin	1	
D29	H4100E2070	Stud	1	SM7/32 (32) ×3

E. STITCH REGULATOR MECHANISM

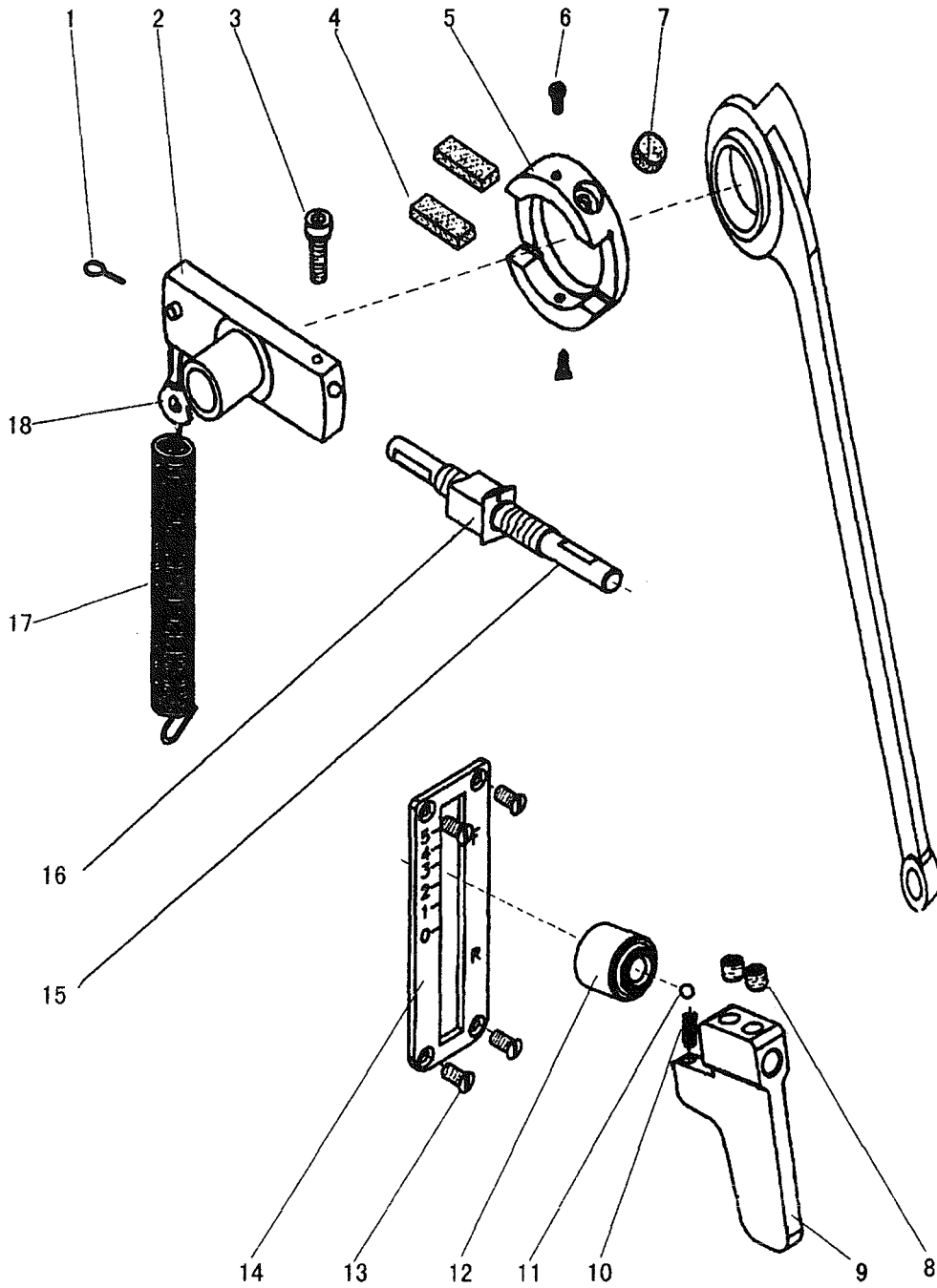

From the library of: Diamond Needle Corp

E. STITCH REGULATOR MECHANISM

Fig. No.	Part No.	Description	Pcs.	Remarks
E01	H601016120	Pin	1	GB/T91 1.6×12
E02	H4105F0661	Slide block	1	
E03	H4105F0662	Screw	1	M5×15.5
E04	H4104F0652	Felt (large)	2	
E05	H4104F0651	Collar	1	
E06	HA106B0676	Screw	2	SM9/64 (40) ×6
E07	H4104F0653	Felt	1	
E08	H3205G1114	Screw	2	M5×5
E09	H4108F0671	Reverse feed lever	1	
E10	H4108F0675	Spring for feed regulator shaft	1	
E11	HE00001032	Steel ball	1	GB/T308 3.17
E12	H4108F0674	Feed regulator screw bar	1	SM9/32 (28) ×15
E13	H4100F2070	Screw	4	SM9/64 (40) ×7
E14	H4100F2060	Dial	1	
E15	H4108F0672	Feed regulator screw bar nut	1	
E16	H4108F0673	Guide bushing	1	
E17	H4100F2030	Spring	1	
E18	H4100F2040	Slide block connecting lever	1	

F. NEEDLE BAR FEEDING MECHANISM

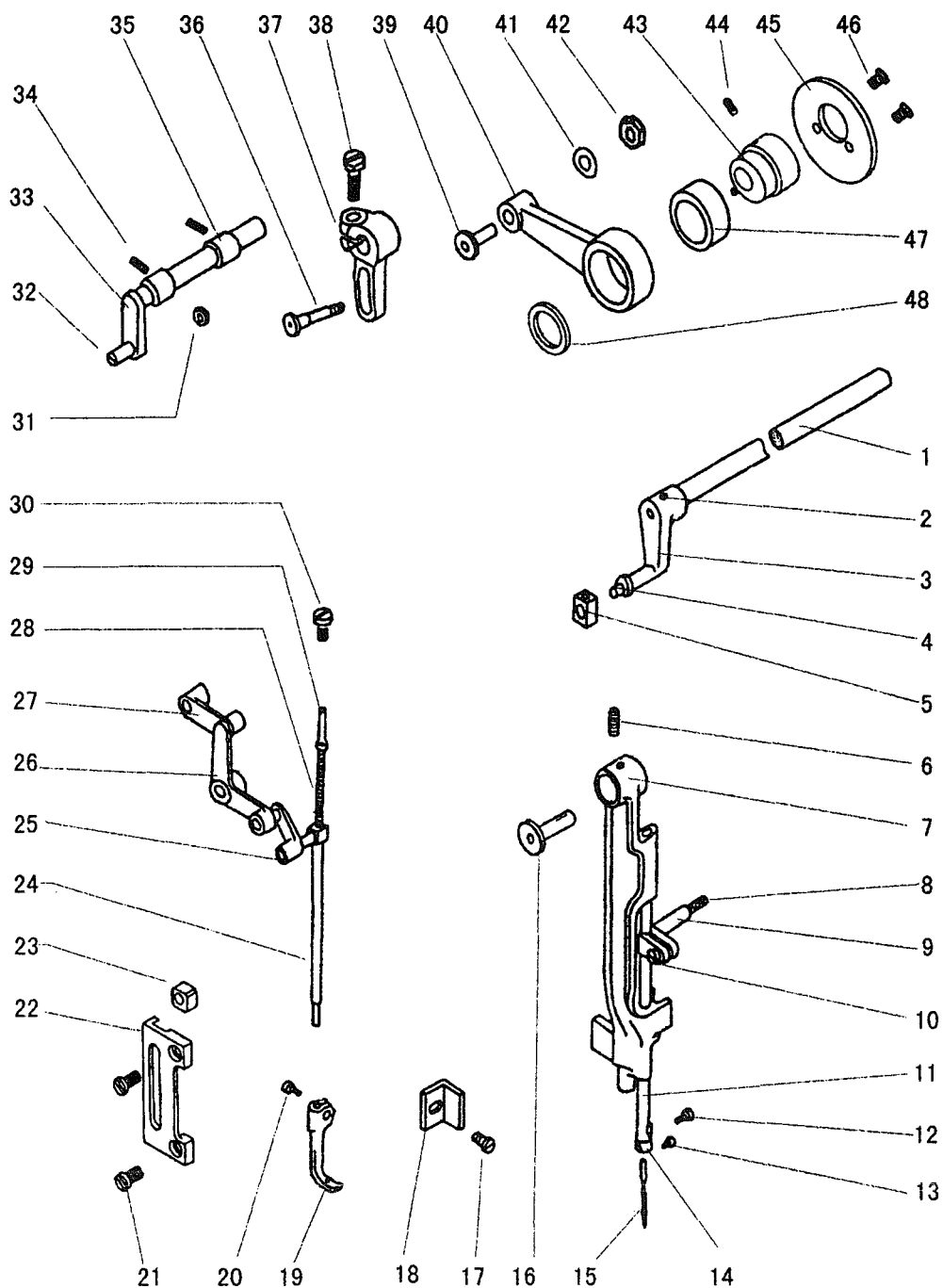

From the library of: Diamond Needle Corp

F. NEEDLE BAR FEEDING MECHANISM

Fig. No.	Part No.	Description	Pcs.	Remarks
F01	H3204D0652	Rock frame crank shaft	1	
F02	H602040250	Hinge pin	1	GB/T117 4×25
F03	H4100G2020	Crank	1	
F04	H3406C0671	Slide block stud	1	
F05	H3100F2270	Slide block	1	
F06	HA100C2020	Screw	1	SM15/64 (28) ×10
F07	H3100F2220	Needle bar rock frame	1	
F08	H3126F0683	Oil wick	1	
F09	H4200F2010	Needle bar connecting stud	1	
F10	HA7311CD06	Screw	1	SM9/64 (40) ×8.5
F11	H3129F0692	Needle bar	1	
F12	HA100C2170	Screw	1	SM1/8 (44) ×4.5
F13	H3129F0691	Screw	1	SM3/32 (56) ×2.5
F14	H3129F0693	Needle bar thread guide	1	
F15	H2000G2030	Needle	1	DP×17 #22
F16	H3100F2200	Pin for rock frame	1	
F17	H3400C2020	Set screw	1	SM11/64 (40) ×12
F18	H3100F2240	Rock frame position bracket	1	
F19	H3111F0651	Vibrating presser foot	1	
F20	HA700F2100	Screw	1	SM11/64 (40) ×7
F21	H3100F2360	Screw	2	SM9/64 (40) ×7
F22	H3100F2340	guide for slide block	1	
F23	H3100F2350	Screw	1	
F24	H3100F2070	Vibrating presser bar	1	
F25	H3100F2030	Presser bar connecting link	1	
F26	H3100F2020	Lifting bell crank	1	
F27	H3100F2010	Lifting bell crank link	1	
F28	H3100F2060	Vibrating presser bar spring	1	
F29	H3100F2050	Vibrating presser bar extension	1	
F30	H3100F2040	Screw	1	SM5/16 (24) ×16
F31	H3112F0662	Nut	1	SM1/4 (28) ×5
F32	H3112F0661	Screw	1	SM1/4 (28) ×9.5
F33	H3112F0663	Lifting rock shaft	1	
F34	HA100B2110	Set screw	2	SM11/64 (40) ×5.5
F35	H3100F2100	Bushing for rock shaft	2	
F36	H3100F2130	Hinge pin	1	
F37	H3115F0672	Crank	1	
F38	H3115F0671	Screw	1	SM1/4 (28) ×16
F39	H3100F2150	Bushing for hinge pin	1	
F40	H3100F2170	Lifting eccentric connection	1	
F41	H005001060	Washer	1	GB/T97.1 6
F42	H3100F2160	Stud	1	SM7/32 (32) ×8
F43	H3100F2330	Lifting eccentric	1	

F. NEEDLE BAR FEEDING MECHANISM

Fig. No.	Part No.	Description	Pcs.	Remarks
F44	HA106D0662	Screw	2	SM1/4 (40) ×4
F45	H3100F2370	Stop ring	1	
F46	HA7311C306	Screw	2	SM9/64 (40) ×7
F47	H3100F2180	Needle bearing	1	DCL1710
F48	HA100G2130	Washer	1	

G. PRESSER FOOT MECHANISM

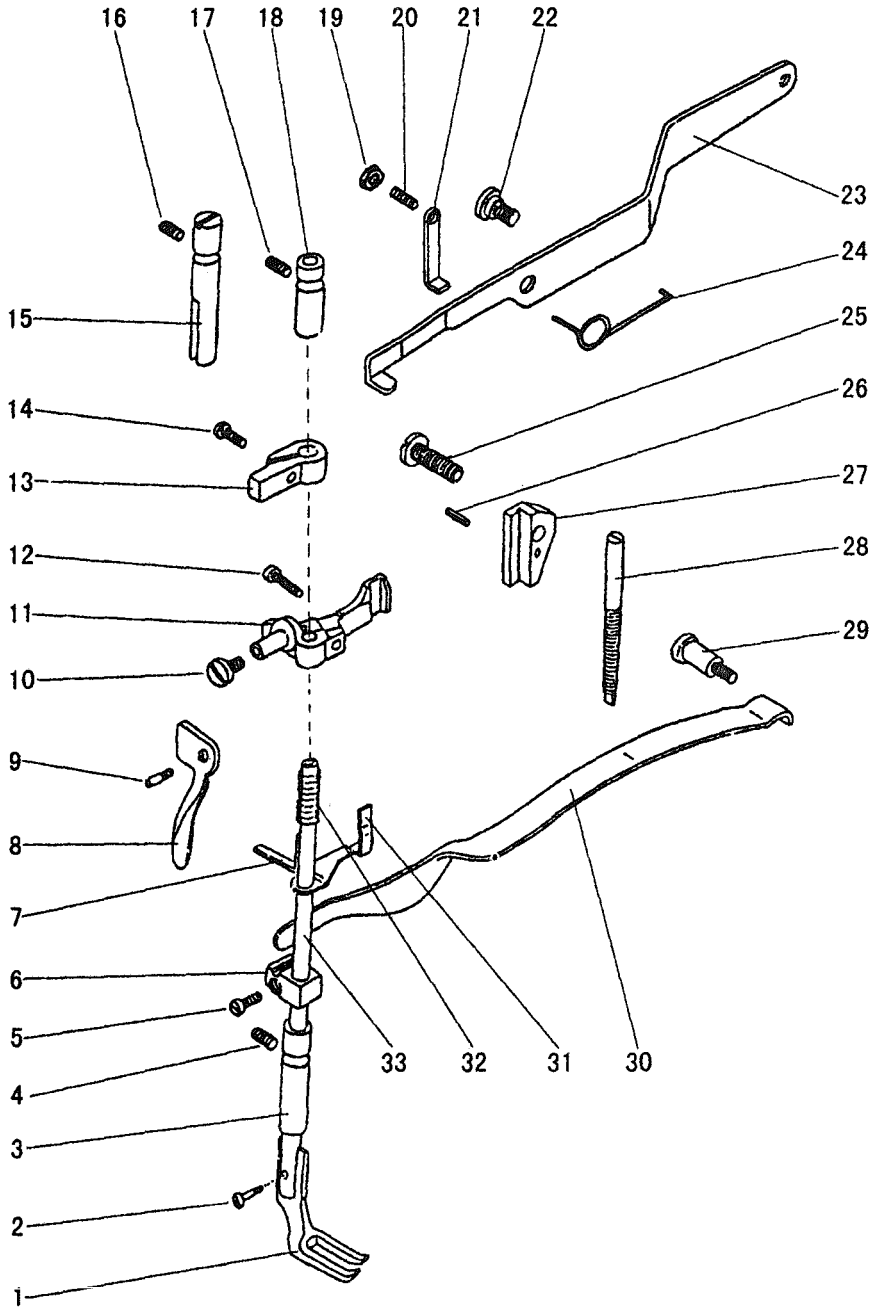

From the library of: Diamond Needle Corp

G. PRESSER FOOT MECHANISM

Fig. No.	Part No.	Description	Pcs.	Remarks
G01	H3100G2110	Lifting presser foot	1	
G02	H3100G2120	Screw	1	SM9/64 (40) ×6
G03	H3104B0656	Presser bar bushing (lower)	1	
G04	HA100C2020	Screw	1	SM15/64 (28) ×10
G05	H2404I0034	Screw	1	SM9/64 (40) ×8.5
G06	H3113G0671	Presser bar spring bracket	1	
G07	H3109G0652	Guide for tension releasing slide	1	
G08	H3100G2070	Presser bar lifter	1	
G09	H3100G2080	Screw	1	SM3/16 (32) ×9.5
G10	H3107G0662	Screw	1	SM11/64 (40) ×8
G11	H3107G0663	Presser bar lifting bracket	1	
G12	H3107G0661	Screw	1	SM11/64 (40) ×14
G13	H3106G0652	Presser bar position guide bracket	1	
G14	H2404I0034	Screw	1	SM9/64 (40) ×8.5
G15	H3100G2020	Presser bar position guide	1	
G16	HA3411D308	Screw	1	SM15/64 (28) ×7
G17	HA100C2020	Screw	1	SM15/64 (28) ×10
G18	H3104B0654	Presser bar bushing (upper)	1	
G19	HA104J6510	Nut	1	SM15/64 (28) ×3
G20	HA104J0659	Screw	1	SM15/64 (28) ×28
G21	H4100H2020	Plate	1	
G22	H3100G2130	Screw	1	SM1/4 (24) ×7
G23	H3100G2140	Knee lifter lifting lever	1	
G24	H4100H2010	Coil spring	1	
G25	H3100G2220	Screw	1	SM1/4 (24) ×20
G26	H609025180	Spring pin	1	GB/T879.1 2.5×18
G27	H3100G2210	Presser bar lifting bracket	1	
G28	H3100G2160	Screw	1	SM1/4 (32) ×37
G29	H3100G2170	Screw	1	SM1/4 (24) ×11
G30	H3100G2150	Presser bar spring	1	
G31	H3109G0651	Tension releasing slide	1	
G32	H3100G2050	Tension releasing spring	1	
G33	H3100G2090	Presser bar	1	

H. ACCESSORIES

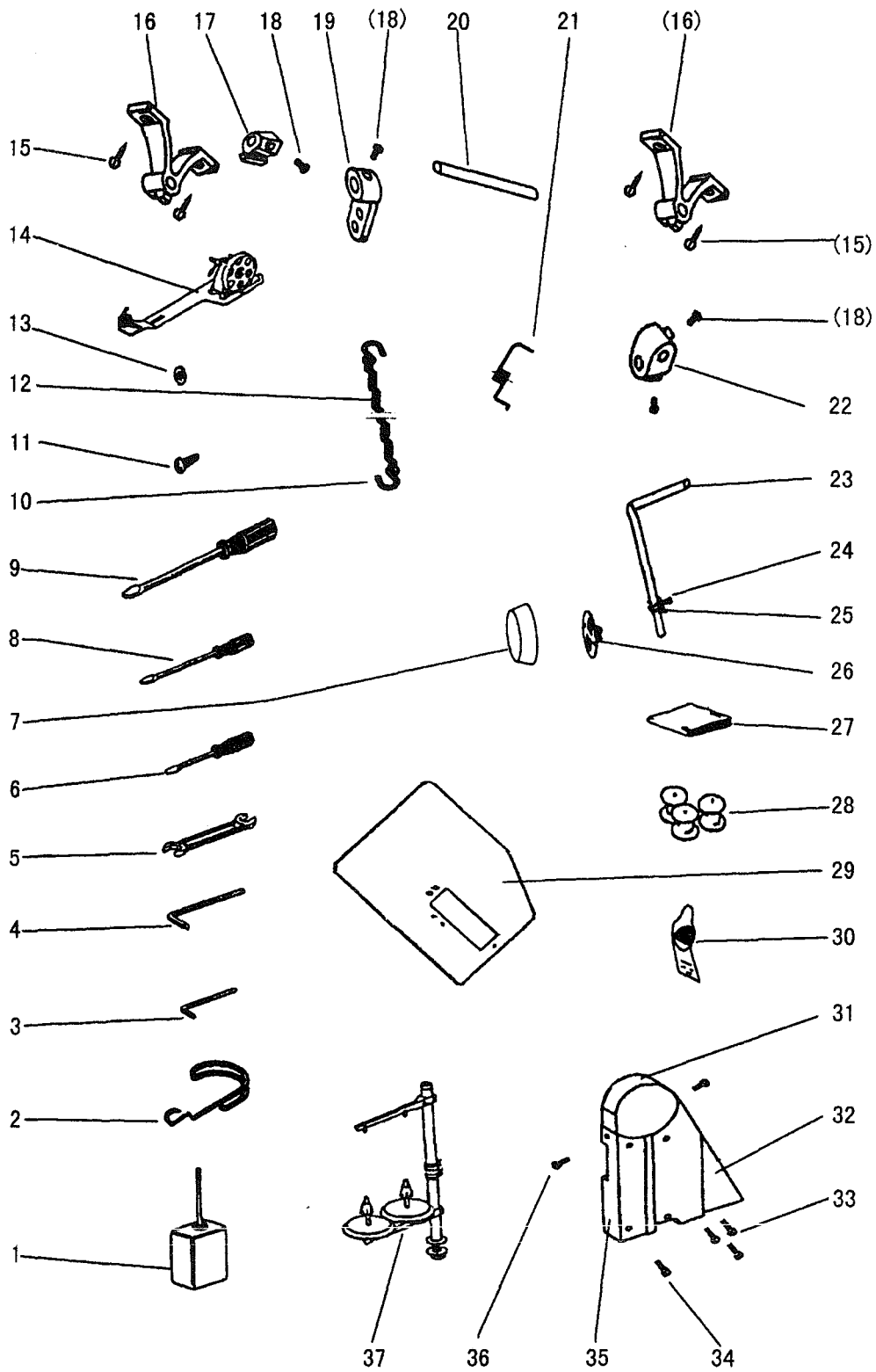

From the library of: Diamond Needle Corp

H. ACCESSORIES

Fig. No.	Part No.	Description	Pcs.	Remarks
H01	H2004O0069	Oil tank	1	
H02	HE204I8001	Walking foot guard cover	1	
H03	H3200L0050	Socket wrench	1	2.5
H04	H4100I2110	Socket wrench	1	4
H05	HJ02100110	Spanner	1	GB/T4388 10×11
H06	HA300J2210	Screw driver (small)	1	
H07	HA106J0668	Knee lifter cover	1	
H08	HA300J2200	Screw driver (middle)	1	
H09	HA300J2070	Screw driver (large)	1	
H10	HPG100E202	Connector	2	
H11	H801045200	Wood screw	2	GB/T99 4.5×20
H12	HPG100E203	Chain	1	
H13	HA300J2230	Washer	2	
H14	HA109J0068	Bobbin winder assay	1	
H15	H802045250	Wood screw	4	GB/T100 4.5×25
H16	H2015O0065	Knee lifter	2	
H17	H2015O0067	Set blore	1	
H18	HA300J2180	Screw	4	SM5/16 (18) ×16
H19	H4100I2010	Knee lifter shaft	1	
H20	H2015O0066	Knee lifter shaft	1	
H21	H2015O0070	Coil spring	1	
H22	HA106J0663	Connector	1	
H23	HA106J0662	Knee lifter shaft	1	
H24	HA106J0667	Screw	1	SM15/64 (28) ×8
H25	HA106J0666	Knee lifter bracket	1	
H26	HA106J0665	Knee lifter plate	1	
H27	HA100J2180	Cover	1	
H28	H2400I2020	Bobbin	3	
H29	H4109I0065	Auxiliary table	1	
H30	H2000G2030	Needle	4	DP×17 #22
H31	H6307L8001	Belt cover (upper)	1	
H32	H4100I2080	Belt cover (right)	1	
H33	HA300J2280	Screw	3	SM15/64 (28) ×8
H34	H2400K0160	Screw	1	SM15/64 (28) ×8
H35	H4100I2090	Belt cover (left)	1	
H36	H2000O0360	Screw	2	SM11/64 (40) ×6
H37	HA200J2030	Thread stand assay	1	GXJ-2

SHANGHAI HUIGONG NO.3 SEWING MACHINE FACTORY

ADD: 1418, Yishan Road, Shanghai, China

Zip Code: 201103

Overseas Business: TEL: 86-21-64853303 FAX: 86-21-64854304

E-mail: highlead@online.sh.cn <http://www.highlead.com.cn>

The description covered in this manual is subject to change for improvement of the commodity without notice

2004.1. Printed