

# Partslist

1

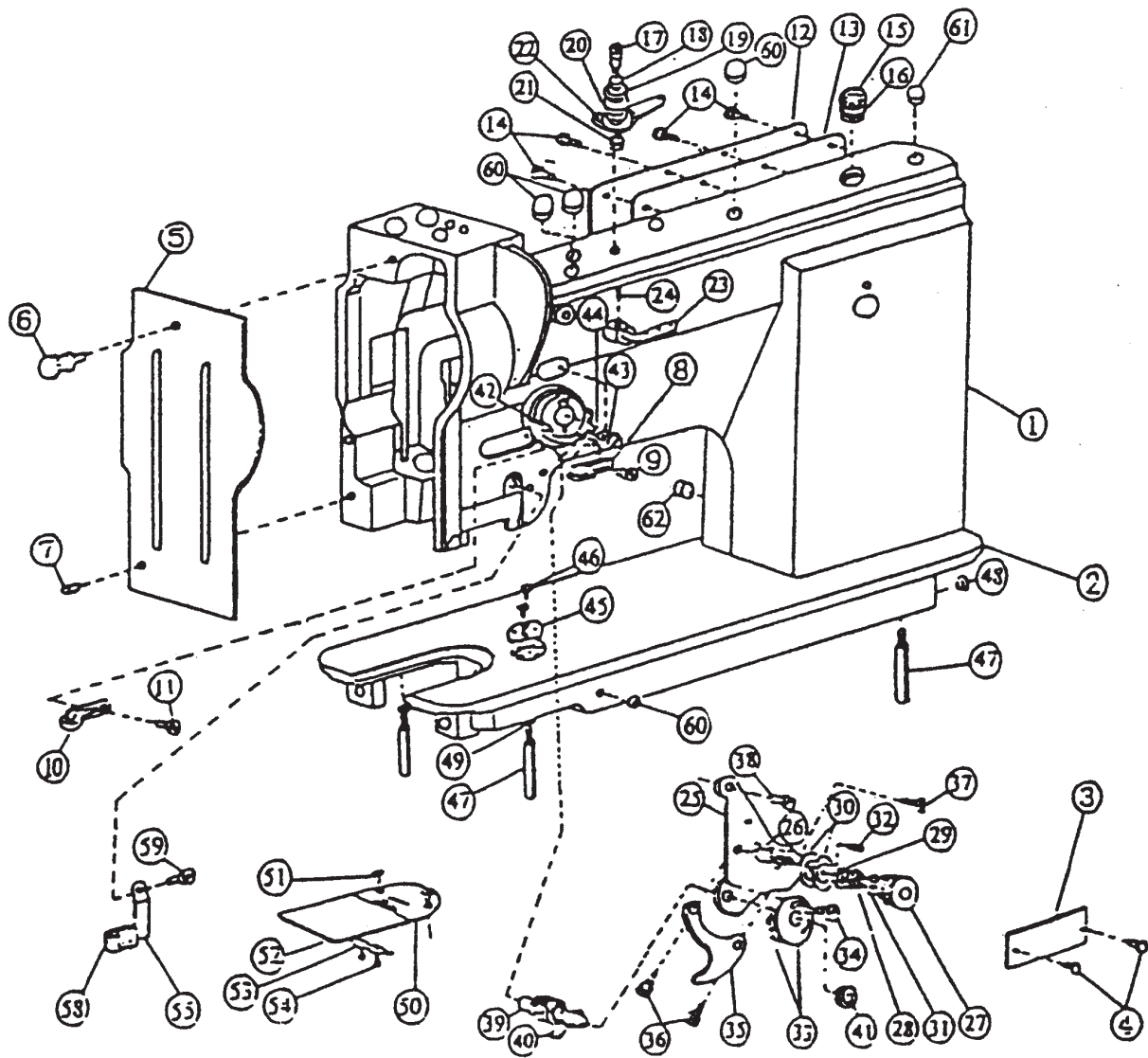

### 1. ARM BED AND ITS ACCESSORIES

No.	Ref. No	Description	Pieces	Remark
1	BM05-01-001A2	Arm	1	
2	BM07-01-001B2	Arm bed	1	
3	BM07-01-002	Trade mark plate	1	
4	GB827-86	Trade mark plate rivet	2	φ 2.5 × 5
5	BM05-01-003	Face plate	1	
6	BM05-01-004	Set screw	1	
7	BM05-01-005	Knock pin	1	
8	BM05-01-006	Thread guide (up)	1	
9	22T1-003C6	Set screw	1	SM9/64" (3.57)× 40/6
10	22T1-003C5	Thread guide (middle)	1	
11	22T1-003C6	Set screw	1	SM9/64" (3.57)× 40/6
12	BM05-01-014	Arm side cover	1	
13	BM05-01-015	Gasket for arm side cover	1	
14	72T1-017	Set screw	8	SM11/64" (4.37)× 40/9
15	12H1-007C1	Oil check window	1	
16	12H1-007C2	O-ring	1	
17	22T1-009E1	Screw type tension stud	1	
18	22T1-009E2	Spring for pretension	1	
19	22T1-009E3	Disc for pretension	2	
20	22T1-009E4	Space for pretension	1	
21	GB896	Stop ring	1	Ring 3
22	22T1-009E5	Pretension thread guide	1	
23	22T1-010	Three-hole thread guide	1	
24	22T1-011	Set screw	1	SM11/64" (4.37)× 40/5
25	BM05-01-007C1	Thread tension bracket	1	
26	BM05-01-007C2	Thread tension stud	1	
27	BM05-01-007C3	Tension regulating nut	1	
28	73T1-002C1	Thread tension spring	1	
29	BM05-01-007C4	Thread tension releasing disc	1	
30	BM05-01-007C5	Thread tension disc	2	
31	BM05-01-007C6	Stop disc	1	
32	BM05-01-007C7	Pin	1	
33	BM05-01-007C8-1	Thread controller disc	1	
	BM05-01-007C8-2	Thread controller disc	1	
34	BM05-01-007C9	Screw	1	SM3/32" (2.38)× 56
35	BM05-01-007C10	Thread tension release plate	1	
36	BM05-01-007C11	Screw	2	
37	BM05-01-007C12	Thread tension release pin	1	
38	72T1-013	Screw	1	SM11/64" (4.37)× 40/5.5
39	BM05-01-008	Thread controller stud	1	
40	BM05-01-009	Thread take-up spring	1	
41	BM05-01-010	Tension thumb nut	1	
42	BM05-01-011	Thread take-up spring stop	1	
43	BM05-01-016	Screw	1	SM9/64" (3.57)× 40/6
44	22T1-011	screw	1	SM11/64" (4.37)× 40/5
45	72T1-014	Cloth guide plate	1	
46	72T1-013	Screw	2	
47	22T1-022	Bed supportor	3	
48	72T1-010	Rubber Plug	1	
49	GB93	Retaining washer	3	Washer 6
50	BM07-01-003	Needle plate	1	
51	72T1-019	Screw	2	SM11/64" (4.37)× 40/8
52	22T1-021G1	Slide board	1	
53	22T1-021G2	Slide board spring	1	
54	22T1-021G3	Screw	2	SM3/32" (2.38)× 56/2.2
55	BM05-01-013	Thread guide (lower)	1	
58	BM03-02-001A3	Felt for thread guide (lower)	1	
59	22T1-003C6	Set Screw	1	SM9/64" (3.57)× 40/6
60	72T1-004C4	Rubber plug	4	φ 11.8
61	72T1-011	Rubber plug	1	φ 5.7
62	72T1-009	Rubber plug	1	φ 8.8

2

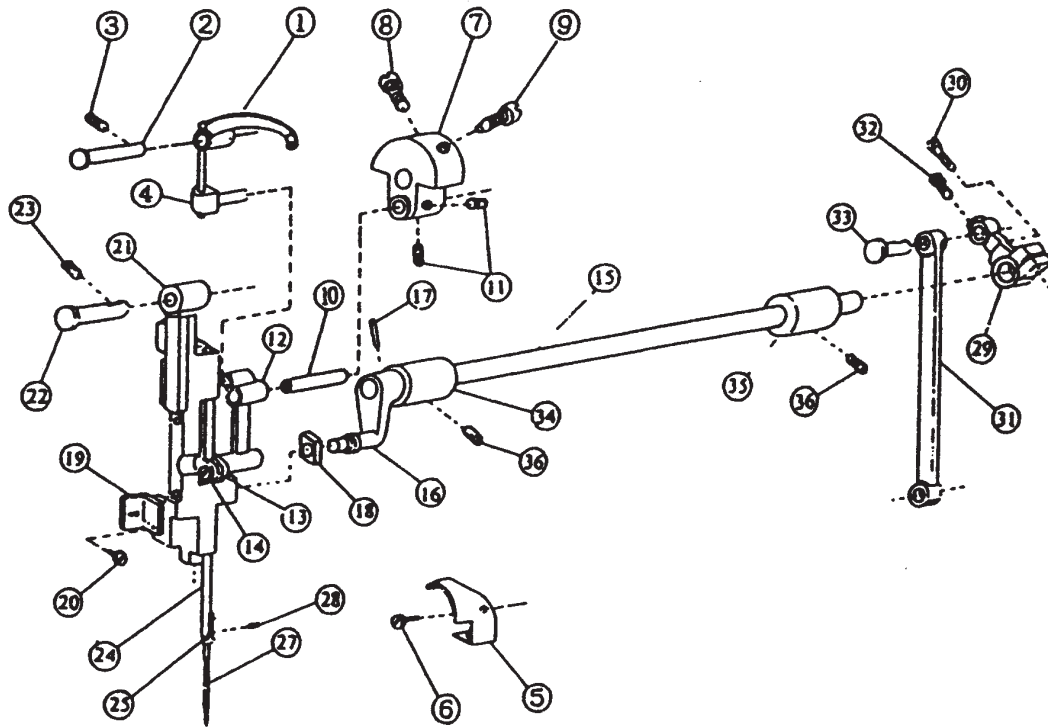

## 2. NEEDLE BAR AND TAKE-UP MECHANISM

No.	Ref. No	Description	Pieces	Remark
1	31H-001	Thread take-up lever	1	
2	BM05-02-002	Hinge pin	1	
3	22T2-002	Set screw	1	SM15/64" (5.95)× 28/10
4	31H-004	Thread take-up lever driving stud	1	
5	BM05-02-004	Oil-guard	1	
6	22T8-011C4	Set screw	1	SM9/64" (3.57)× 40/4.5
7	BM05-02-005A1	Needle bar crank	1	
8	22T2-006	Set screw	1	SM9/32" (7.14)× 28/13
9	22T2-007	Set screw	1	SM9/32" (7.14)× 28/14
10	BM05-02-006	hinge pin	1	
11	72T2-004B2	Set screw	2	SM1/4" (6.35)× 40/6
12	BM05-02-007	Needle bar link	1	
13	BM05-02-008	Needle bar adaptor	1	
14	22T7-015	Set screw	1	SM9/64" (3.57)× 40/11
15	BM05-02-009B1	Needle bar rock frame rock shaft	1	
16	BM05-02-009B2	Crank (left)	1	
17	GB117	Pin for crank	1	Taper pin A3 × 16
18	BM05-02-009B3	Slide block for needle bar rock frame	1	
19	BM05-02-009B4	Position bracket	1	
20	72T2-003	Screw	1	SM1 1/64" (4.37)× 40/8
21	BM05-02-010	Needle bar rock frame	1	
22	BM05-02-011	Hinge pin	1	
23	22T2-002	Screw	1	SM15/64" (5.95)× 28/10
24	BM05-02-012	Needle bar	1	
25	BM05-02-017	Thread guide for needle bar	1	
27		Needle	1	DP × 17 22 #
28	22T2-017	Needle clamp screw	1	SM1/8" (3.18)× 44/4.5
29	BM07-02-001C1	Crank (right)	1	
30	BM02-08-007	Screw	1	SM1/4" (6.15)× 24/16
31	BM07-02-001C2	Crank lever link	1	
32	72T3-005D1a3	Screw (right)	1	SM15/64" (5.95)× 28/6
33	BM05-05-003	Hinge pin (upper)	1	
34	BM05-02-015	Bushing for rock shaft (left)	1	
35	BM05-02-016	Bushing for rock shaft (right)	1	
36	22T2-002	Screw	2	SM15/64" (5.95)× 28/10

**3**

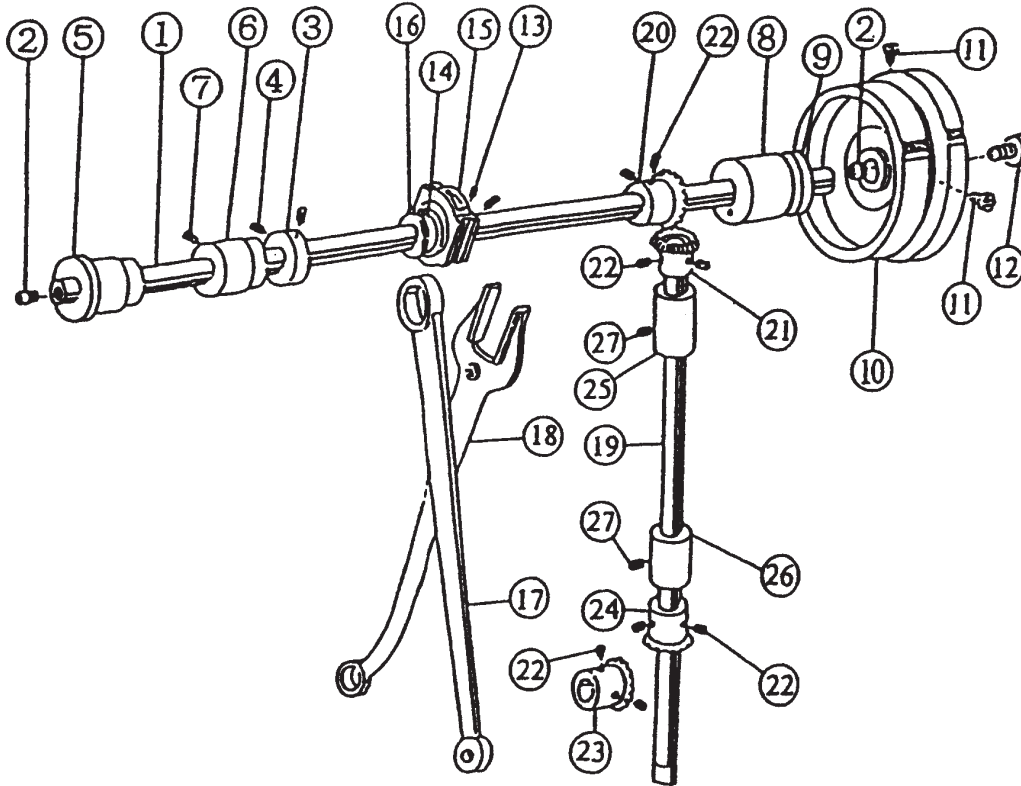

### 3. ARM SHAFT AND VERTICAL SHAFT MECHANISM

No.	Ref. No	Description	Pieces	Remark
1	BM05-03-001A1	Arm shaft	1	
2	22T3-001A2	Rubber plug	2	
3	22T6-005B1	Collar for arm shaft	1	
4	22T3-002B2	Set screw	2	SM1/4" (6.35)× 40/4
5	22T3-003	Arm shaft bushing (left)	1	
6	BM05-03-007	Arm shaft bushing (middle)	1	
7	22T2-002	Set screw	1	SM15/64" (5.95)× 28/10
8	BM05-03-006	Arm shaft bushing (right)	1	
9	22T3-006F	Oil seal	1	
	22T3-006F2	Spring for oil seal	1	
10	BM02-03-001	Balance wheel	1	
11	22T3-007C2	Set screw	2	SM15/64" (5.95)× 28/12
12	22T3-008	Set screw	1	SM11/32" (8.73)× 28/10
13	72T3-005D1a3	Set screw	2	SM15/64" (5.95)× 28/7
14	11H3-002B1a1	Feed lifting eccentric	1	
15	72T3-005D1a2	Eccentric sleeve	1	
16	22T3-009D1b	Retaining ring	1	
17	BM04-03-002A2	Crank rod for feed lifting rock	1	
18	BM07-03-001B2	Feed forked connection	1	
19	BM05-03-003	Vertical shaft	1	
20	22T3-010E2a1-2	Bevel gear for arm shaft	1	
21	22T3-010E2a2-2	Bevel gear for vertical shaft (upper)	1	
22	22T2-005B3	Set screw	8	SM1/4" (6.35)× 40/7
23	22T3-010E2b1-2	Bevel gear for hook shaft	1	
24	22T3-010E2b2-2	Bevel gear for vertical shaft (lower)	1	
25	BM05-03-004	Vertical shaft bushing (upper)	1	
26	BM05-03-005	Vertical shaft bushing (lower)	1	
27	22T2-002	Set screw	2	SM15/64" (5.95)× 28/10

4

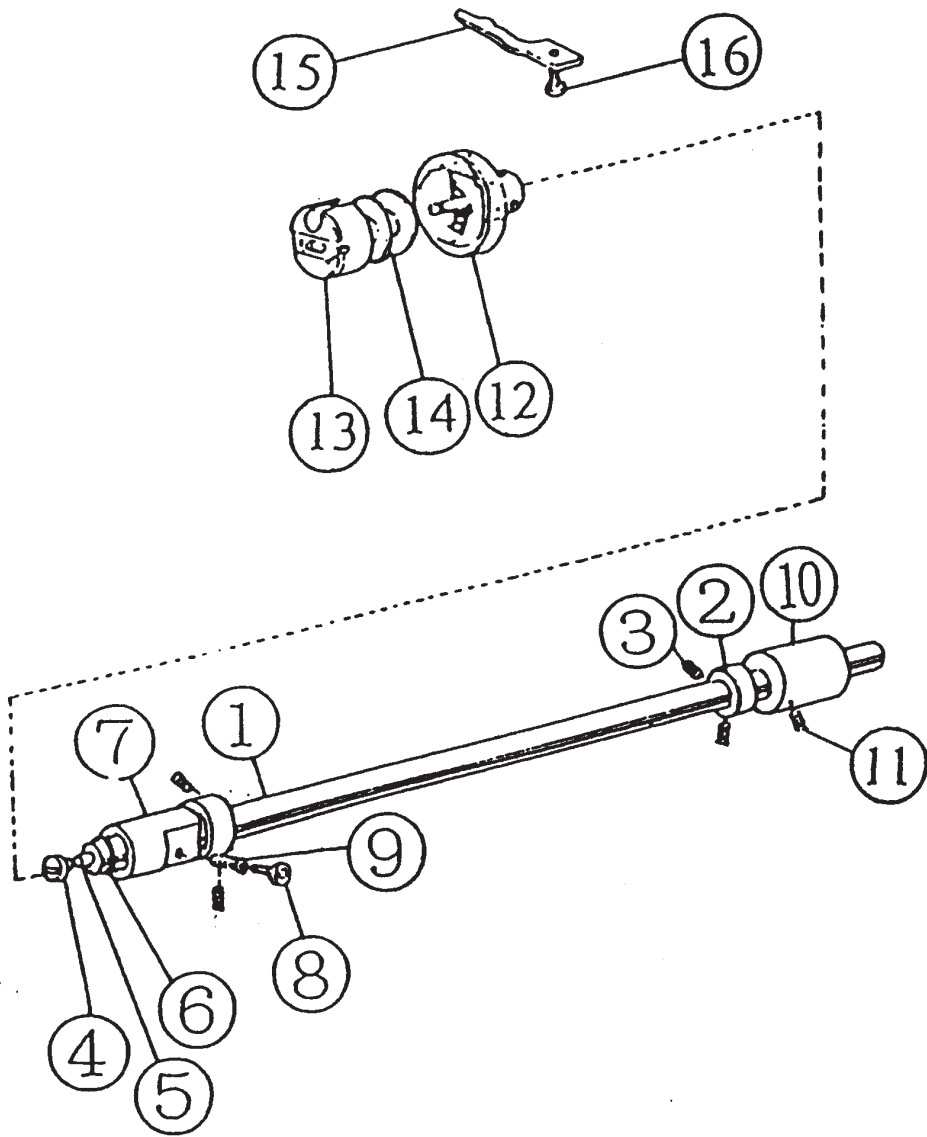



#### 4. HOOK SHAFT MECHANISM

No.	Ref. No	Description	Pieces	Remark
1	BM05-04-001	Rotating hook shaft	1	
2	72T4-002B1	Collar for hook shaft	2	
3	72T4-002B2	set screw	4	SM15/64" (5.95)× 28/4.5
4	22T4-001A1a1	Filter screw	1	SM3/16" (4.76)× 32
5	22T4-001A1a2	Filter	1	
6	22T4-003G	Oil seal for rotating hook shaft	1	
7	22T4-004	Hook shaft bushing (left)	1	
8	72T4-003	oil adjusting screw	1	
9	22T4-006	Spring for oil adjuster	1	
10	BM07-04-001	Hook shaft bushing (right)	1	
11	22T2-002	Set screw	1	SM15/64" (5.95)× 28/10
12	HSM-A(5)	Rotating hook complete	1	
13	BC-STH	Bobbin case	1	
14	11H4-001	Bobbin	1	
15	74T4-004	Rotating hook positioner	1	
16	22T4-015	Set screw	1	SM11/64" (4.37)× 40/10

5

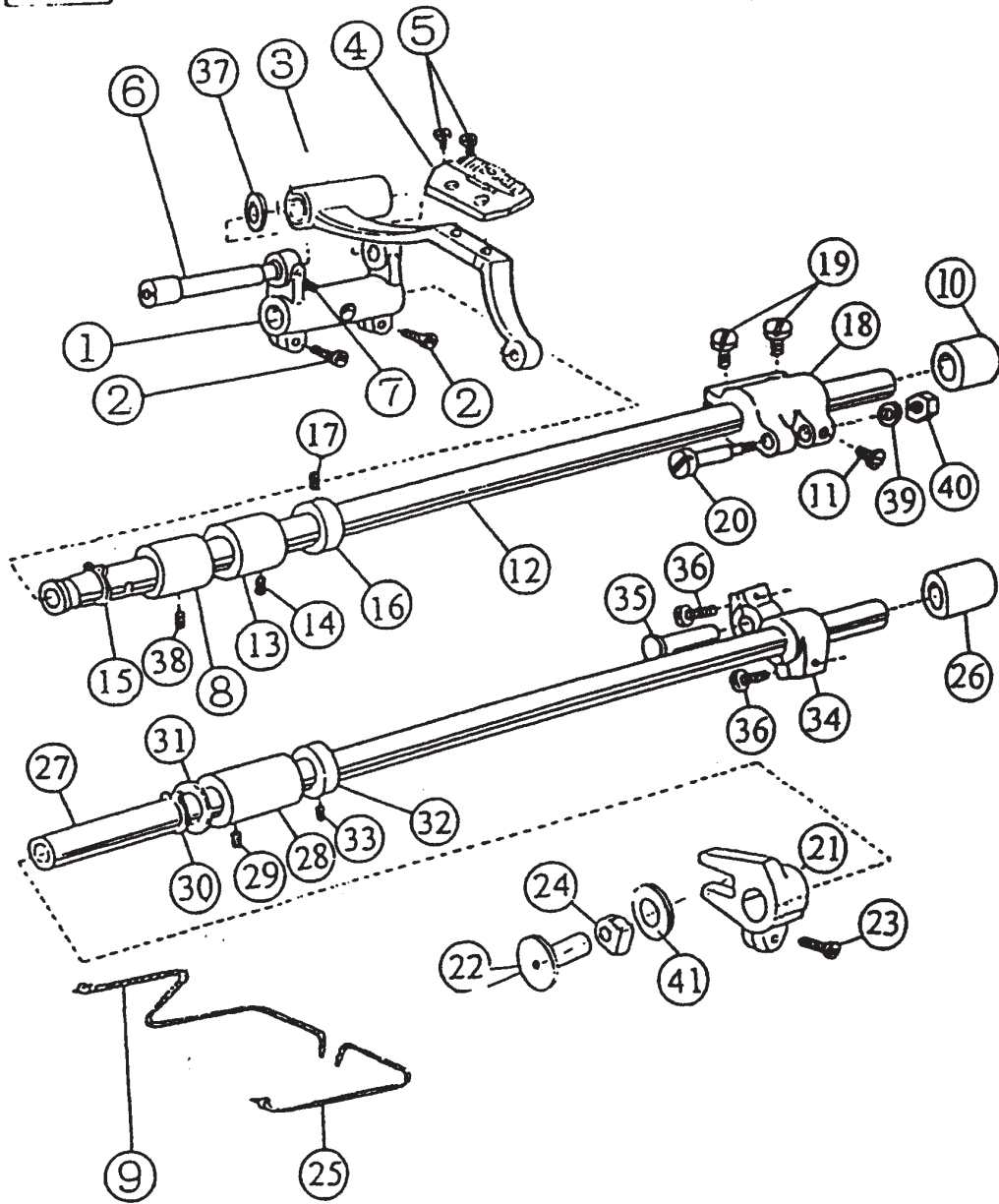

### 5. FEED LIFTING MECHANISM

No.	Ref. No	Description	Pieces	Remark
1	22T6-001A1a	Feed bar crank	1	
2	72T6-001A6	Screw	2	SM3/16" (4.76)× 28/15
3	BM11-06-001A1	Feed bar	1	HG128-C
4	BM07-05-001	Feed dog	1	
5	22T6-001A4	Screw	2	SM1/8" (3.18)× 44/6
6	11H6-004	Shaft for feed bar	1	
7	22T2-019	Screw	1	SM11/64" (4.37)× 40/8
8	11H6-007	Bushing for feed rock shaft (left)	1	
9	72T6-001A5	Oil braid	1	2.5 × 315
10	11H6-006	Bushing for feed rock shaft (right)	1	
11	22T5-001A4	Screw	1	SM15/64" (5.95)× 28/10
12	11H6-001	Feed rock shaft	1	
13	11H6-008	Bushing for feed rock shaft	1	
14	72T4-002B2	Screw	1	SM15/64" (5.95)× 28/4.5
15	GB894	C-type stop ring	1	ring 15
16	22T6-005B1	Collar for feed rock shaft	1	
17	22T3-002B2	Screw	2	SM1/4" (6.35)× 40/4
18	BM07-05-003	Feed rock shaft crank	1	
19	22T6-001A1b	Screw	2	SM3/16" (4.76)× 28/12
20	BM07-05-002	Hige pin	1	
21	31H4-014	Feed lifting rock shaft crank (left)	1	
22	72T6-002B1b	Hinge pin	1	
23	GB70	Screw	1	M5 × 12
24	72T6-007D1a	Feed lifting connection sleeve	1	
25	72T6-002B4	Oil braid	1	φ 2.5 × 265
	72T6-002B2		1	
26	11H6-010	Bushing for feed lifting rock shaft (right)	1	
27	54T6-002	Feed lifting rock shaft	1	
28	22T6-012	Bushing for feed lifting rock shaft	1	
29	22T2-002	Screw	1	SM15/64" (5.95)× 28/10
30	GB894	C-cype stop ring	1	ring 15
31	22T6-013	Washer	1	
32	22T6-005B1	Collar for feed lifting rock shaft	1	
33	22T3-002B2	Screw	2	SM1/4" (6.35)× 40/4
34	72T6-003C1	Feed lifting rock shaft crank (right)	1	
35	22T6-007	Hinge pin	1	
36	22T6-001A1b	Screw	2	SM3/16" (4.76)× 28/12
37	22T6-001A6	Washer	1	
38	72T4-002B2	Screw	1	SM15/64" (5.95)× 28/4.5
39	BM02-08-012	Washer	1	
40	BM02-08-048	Screw nut	1	SM15/64" (5.95)× 28
41	72T6-007D1b	Washer	1	

6

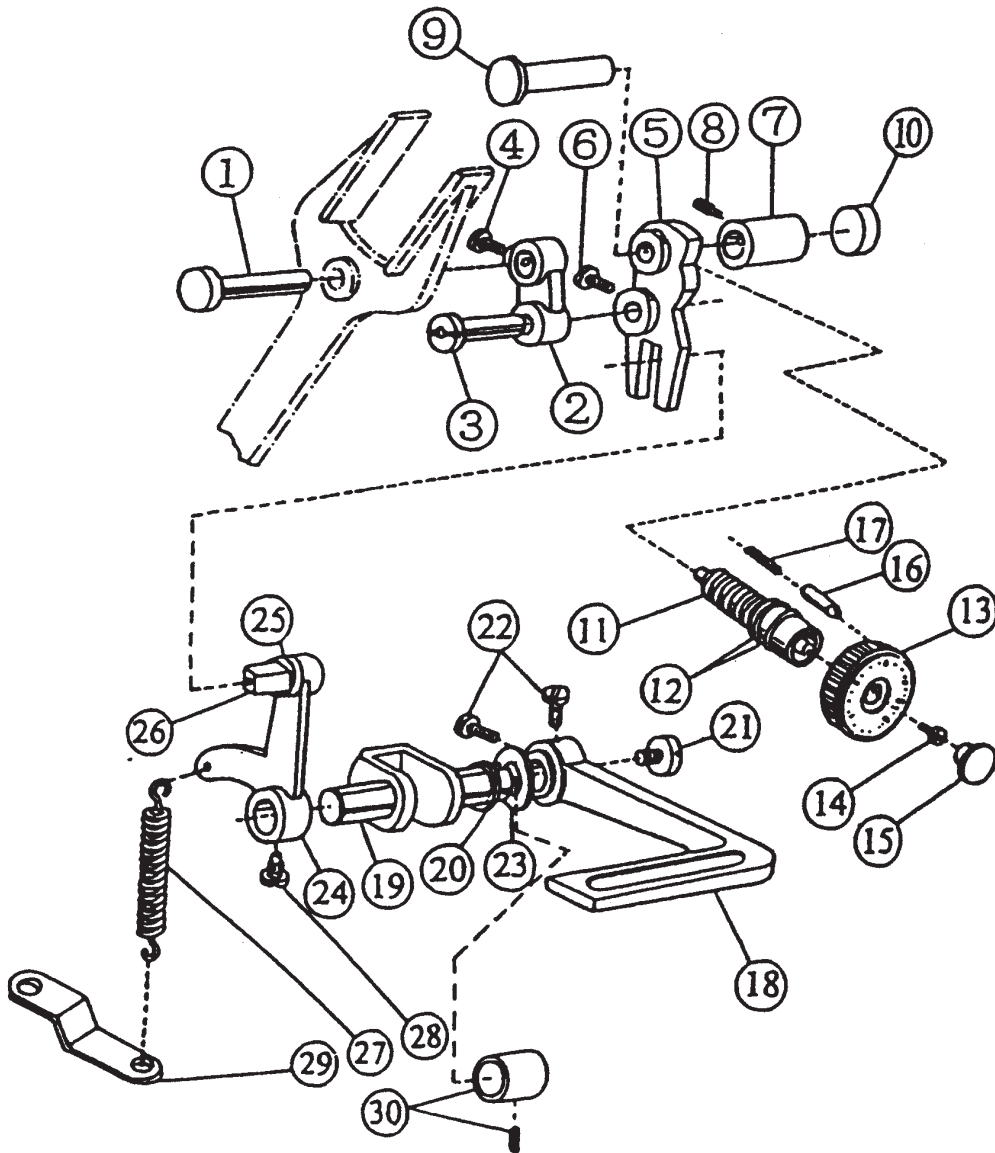

### 6. STITCH LENGTH REGULATING MECHANISM

No.	Ref. No	Description	Pieces	Remark
1	BM01-06-001A1	Hinge pin	1	
2	BM01-06-001A2	Feed connecting link	1	
3	BM01-06-003	Hinge pin for feed connecting link	1	
4	22T5-001A4	Set screw	1	SM15/64" (5.95)× 28/10
5	73T5-002B1	Feed regulator	1	
6	22T5-001A4	Set screw	1	SM15/64" (5.95)× 28/10
7	BM05-06-001	Feed regulator bushing	1	
8	BM05-06-005	Set screw	1	SM15/64" (5.95)× 28/15
9	BM05-06-007	Hinge pin for feed regulator	1	
10	72T5-003	Rubber plug	1	φ 20 × 4
11	73T5-003C1	Feed regulator screw bar	1	
12	22T5-006C4	O-ring	2	14 × 2.4
13	BM03-05-001	Dial	1	
14	22T5-006C3	Screw	1	SM3/16" (4.76)× 28/8
15	72T5-005	Rubber plug	1	
16	22T5-008	Stopper pin	1	
17	22T5-009	Spring for stopper pin	1	
18	72T5-006C1	Reverse feed lever	1	
19	BM07-06-002D1	Reverse feed lever shaft	1	
20	22T5-010D2b	O-ring	1	9 × 1.9
21	22T5-010D3	Screw	1	SM3/16" (4.76)× 28/6.5
22	22T5-001A4	Screw	2	SM15/64" (5.95)× 28/10
23	22T5-011	Washer	1	
24	22T5-012E1	Reverse feed crank	1	
25	22T5-012E1a1	Slide block pin	1	
26	22T5-012E1a2	Slide block	1	
27	BM02-05-002	Spring for reverse feed crank	1	
28	22T5-013	Screw	1	SM15/64" (5.95)× 28/14
29	22T5-014	Bracket for spring	1	
30	BM05-06-003	Bushing for reverse feed lever shaft	1	
31	22T1-011	Screw	1	SM11/64" (4.37)× 40/5

7

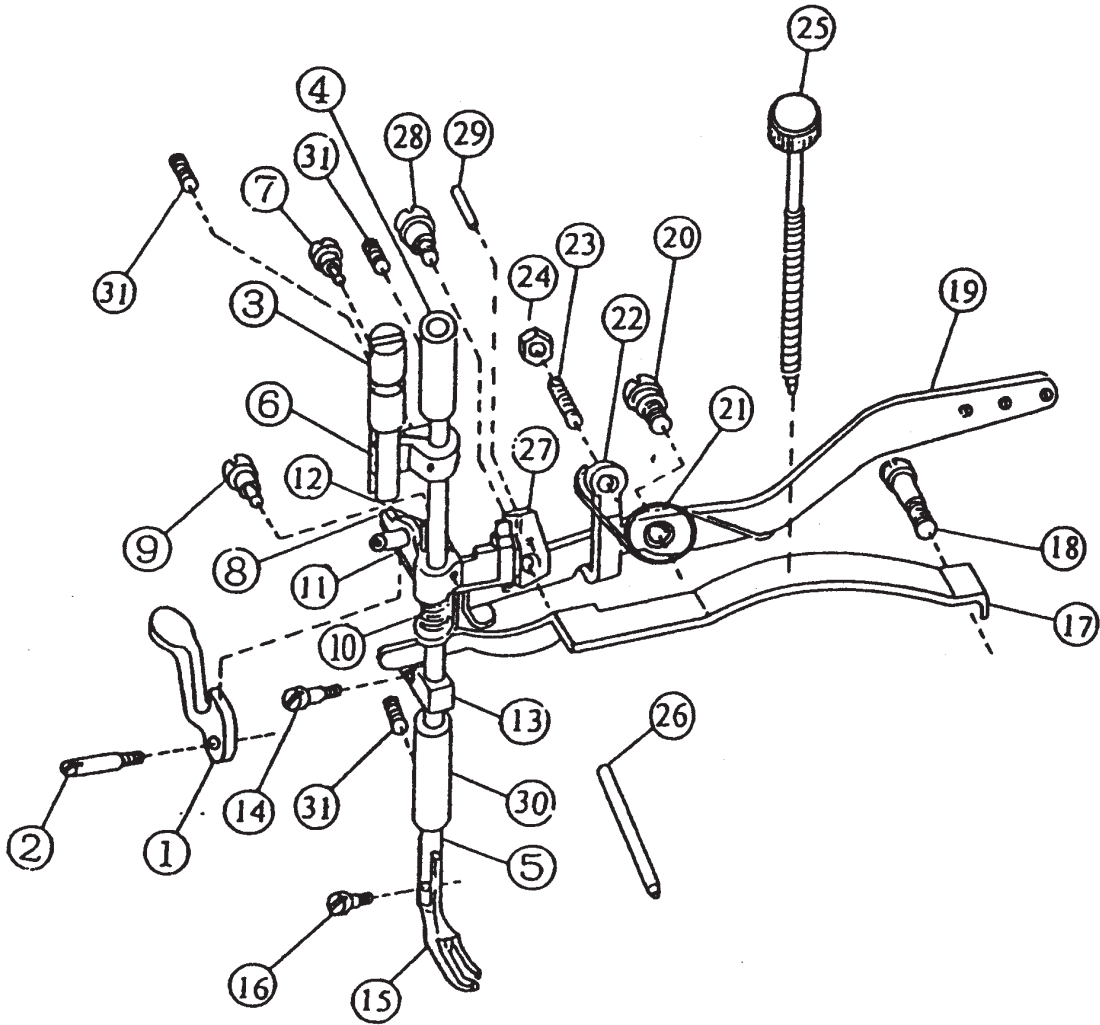

## 7. PRESSER FOOT MECHANISM

No.	Ref. No	Description	Pieces	Remark
1	BM05-07-001	Presser foot lifter	1	
2	BM05-07-002	Set screw	1	
3	BM05-07-003	Presser bar position guide	1	
4	BM05-07-004	Presser bar bushing (upper)	1	
5	BM05-07-005	Presser bar	1	
6	BM05-07-006	Presser bar position guide bracket	1	
7	22T2-001A9	Screw	1	SM 9/64" (3.57) × 40/6
8	BM05-07-007	Presser bar lifting bracket	1	
9	22T6-008D3	Screw	1	SM 11/64" (4.37) × 40/12
10	BM05-07-008	Presser bar spring	1	
11	BM05-07-009A1	Thread tension release slide	1	
12	BM05-07-009A2	Pin for thread tension release slide	1	
13	BM05-07-010	Bracket for presser bar spring	1	
14	BM05-07-021	Screw	1	SM 9/64" (3.57) × 40/10
15	BM05-07-012	Out presser foot	1	
16	BM05-07-013	Screw	1	
17	BM05-07-014	Presser bar spring (flat)	1	
18	BM05-07-015	Screw	1	
19	BM05-07-016	Knee lifter lifting lever	1	
20	22T7-005-001	Screw	1	
21	BM05-07-017	Retracting spring for lever	1	
22	BM05-07-018	Retracting spring bracket	1	
23	22T9-001A9	Screw	1	SM 15/64" (5.95) × 28/28
24	22T9-001A10	Nut	1	SM 15/64" (5.95) × 28
25	BM05-07-019	Pressure regulating screw	1	
26	BM05-07-020	Thread tension release pin	1	
27	BM05-07-022	Presser bar lifting bracket guide	1	
28	BM02-08-007	Screw	1	SM 1/4" (6.35) × 24/16
29	BM05-07-023	Pin	1	
30	BM05-07-011	Presser bar bushing (lower)	1	
31	22T2-002	Screw	3	SM 15/64" (5.95) × 28/10

8

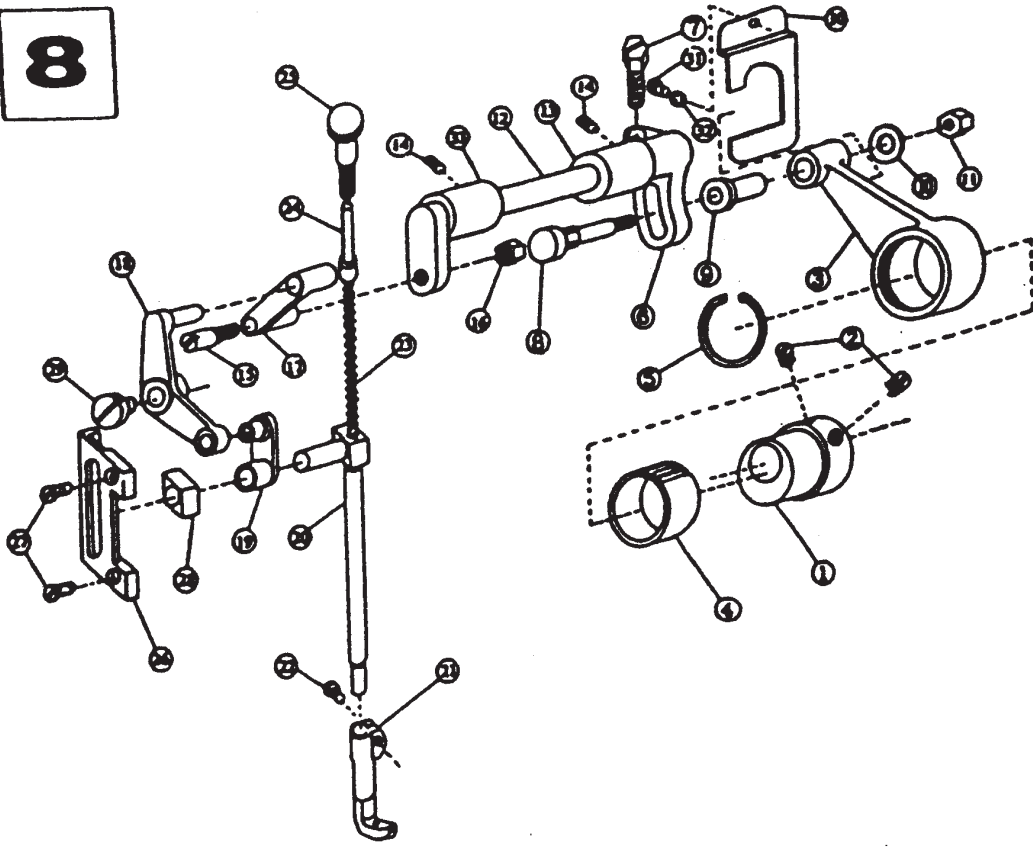



### 8. PRESSER LIFTING MECHANISM

No.	Ref. No	Description	Pieces	Remark
1	BM05-08-001A1	Lifting eccentric	1	
2	22T3-002B2	Screw	2	SM 1/4" (6.35) × 40/4
3	BM05-08-001A2	Lifting eccentric connection	1	
4	BM05-08-001A3	Needle bearing	1	
5	GB893	Retaining ring	1	Ring 30
6	BM05-08-002B1	Adjusting crank for eccentric connection	1	
7	BM05-08-002B2	Set screw	1	
8	BM05-08-003	Screw for lifting eccentric connecting collar	1	
9	BM05-08-004	Lifting eccentric connecting collar	1	
10	BM05-08-005	Washer	1	
11	BM05-08-006	Nut	1	SM 3/16" (4.76) × 28
12	BM05-08-007	Lifting rock shaft	1	
13	BM02-08-004	Lifting rock shaft bushing (right)	1	
14	22T1-011	Screw	2	SM 11/64" (4.37) × 40/5.5
15	BM05-08-008	Hinge pin	1	SM 1/4" (6.35) × 40
16	BM05-08-009	Hinge pin nut	1	
17	BM05-08-010	Lifting bell crank link	1	
18	BM05-08-011	Lifting bell crank	1	
19	BM05-08-012	Presser lifting link	1	
20	BM05-08-013	Vibrating presser bar	1	
21	BM05-08-014	Vibrating presser foot	1	
22	22T2-001A9	Screw	1	SM 9/64" (3.57) × 40/6
23	BM05-08-015	Vibrating presser bar spring	1	
24	BM05-08-016	Spring guide rod	1	
25	BM05-08-017	Adjusting bolt	1	
26	BM05-08-018	Guide for slide block	1	
27	22T2-001A9	Screw	2	SM 9/64" (3.57) × 40/6
28	BM05-08-019	Slide block for vibrating presser bar	1	
29	BM05-08-020	Screw	1	
30	BM05-08-021	Oil seal plate	1	
31	22T2-004	Screw	1	SM 11/64" (4.37) × 40/5.5
32	GB97	Washer	1	Washer 5
33	BM05-08-022	Lifting rock shaft bushing (left)	1	

9

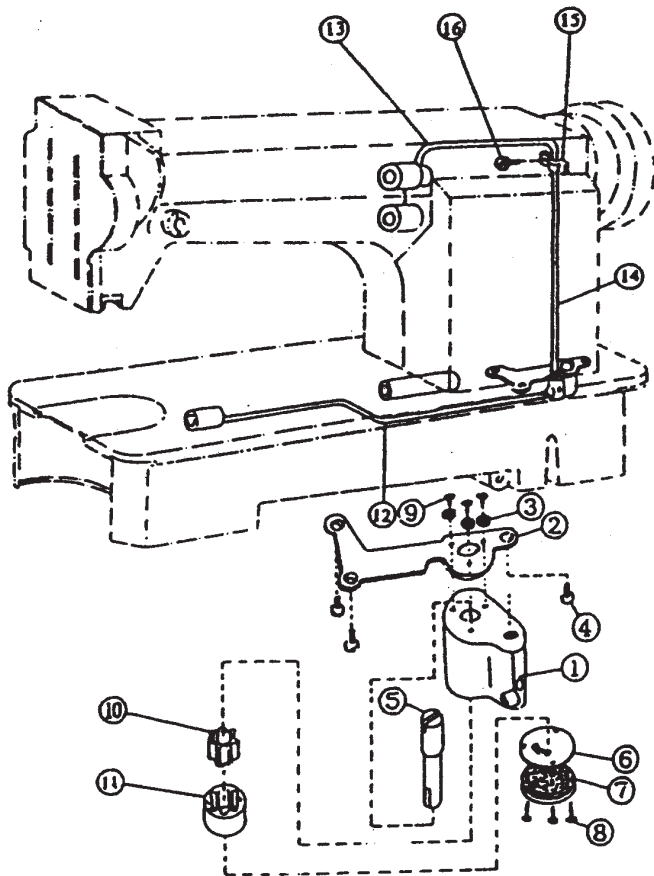

### 9. LUBRICATING MECHANISM

No.	Ref. No	Description	Pieces	Remark
1	BM03-09-001	Oil pump body	1	
2	BM07-09-002	Oil pump body plate	1	
3	22T1-007	Washer	3	
4	72T2-003	Screw	3	SM11/64" (4.37) × 40/8
5	BM03-09-002	Oil pump shaft	1	
6	BM03-09-003	Oil pump body guide plate	1	
7	11H8-008B1	Oil pump screen	1	
8	11H8-010	Set screw	3	SM1/8" (3.18) × 44/8
9	72T2-003	Set screw	3	SM11/64" (4.37) × 40/8
10		Gear (inner)	1	
11		Gear	1	
12	BM07-09-003A1	Oil pipe for hook shaft	1	
	22T8-010B1	Pipe connection for hook shaft	1	
13	BM05-09-001	Oil pipe for arm shaft (upper)	1	
14	BM07-09-004B1	Oil pipe for arm shaft (lower)	1	
	22T8-013D2	Pipe connection for arm shaft	1	
15	BM01-08-004	Pipe hold for arm shaft	1	
16	72T2-003	Set screw	1	SM11/64" (4.37) × 40/8

10

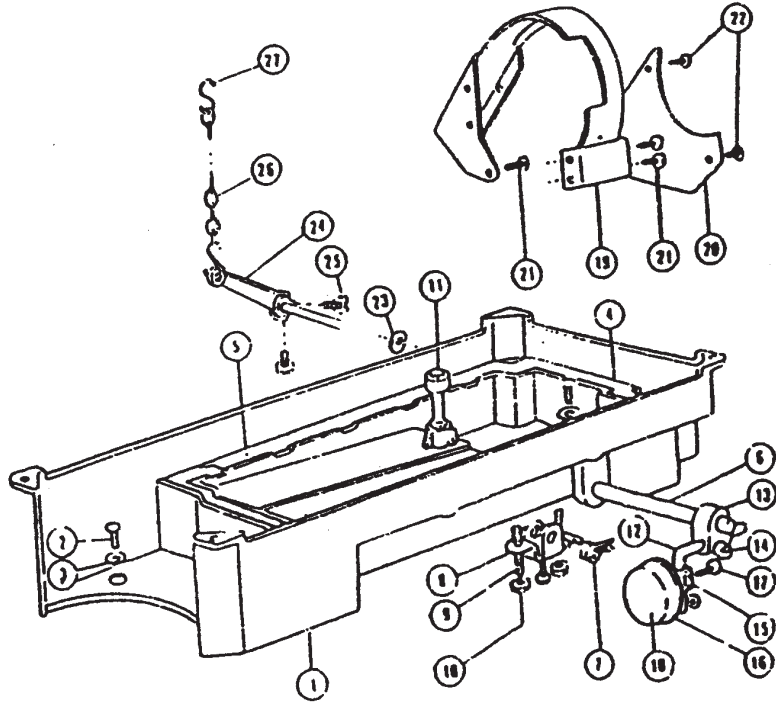

### 10. OIL RESERVOIR AND OTHER ACCESSORIES

No.	Ref. No	Description	Pieces
1	74T9-001A1	Oil reservoir	1
2	22T9-001A2	Oil drain screw	1
3	22T9-001A3	Washer	1
4	22T9-001A4	Gasket for oil reservoir (big)	1
5	22T9-001A5	Gasket for oil reservoir (small)	1
6	BM05-10-001	Hinge pin for knee lifter	1
7	22T9-001A7	Retracting spring for knee lifter	1
8	22T9-001A8	Knee lifter stop bracket	2
9	22T9-001A9	Adjusting screw	2
10	22T9-001A10	Lock nut	1
11	22T9-003B1	Knee lifter lifting rod	1
12	22T9-003B2	Knee lifter bell crank	1
13	22T9-003B3	Joint for knee lifter bell crank	2
14	72T9-018	Set screw	1
15	22T9-003B6	Bracket for knee lifter plate	1
16	22T9-003B5	Knee lifter plate	1
17	22T9-003B7	Set screw	1
18	22T9-003B8	Pad for knee lifter plate	1
19	22T9-004C1	Belt cover bracket	1
20	22T9-004C2	Belt cover plate	3
21	72T1-017	Screw	3
22	72T9-028	Screw	1
23	GN896	Stop ring	1
24	BM05-10-002	Knee lifter rod crank	2
25	GB84	Set screw	1
26		Chain	1
27	GN1-1	Chain hook	2

11

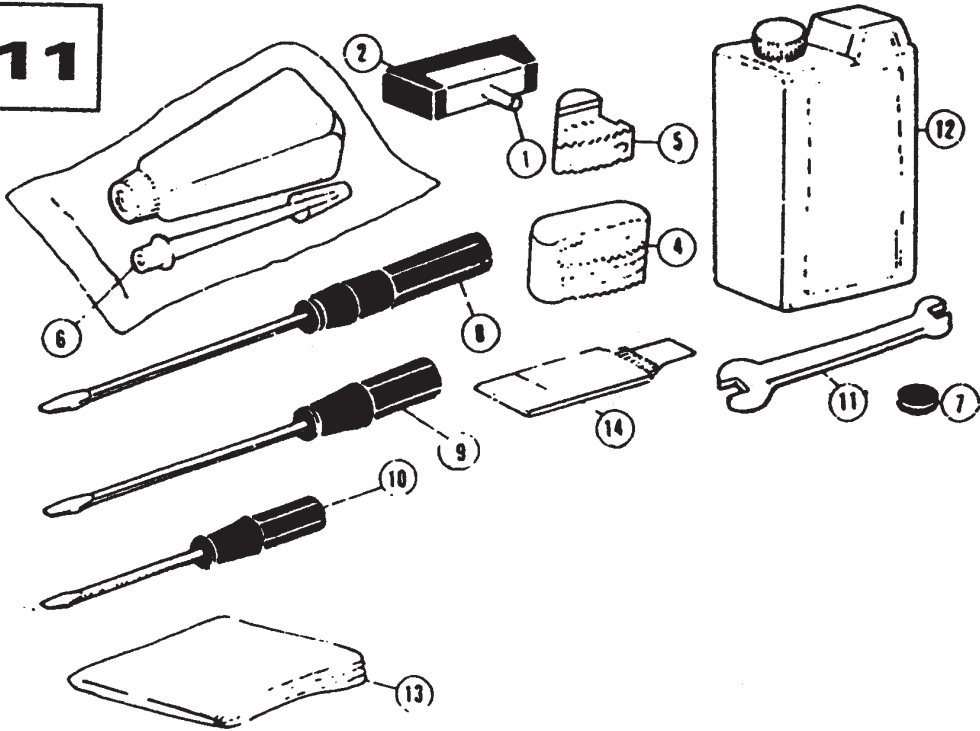

**11. ACCESSORIES**

No.	Ref. No	Description	Pieces
1	22T9-007F1	Hinge of machine head	2
2	72T9-004C1	Rubber socket for hinge	2
4	72T9-005	Rubber cushion (big)	2
5	72T9-006	Rubber cushion (small)	2
6	22T9-011	Oiler	1
7	22T9-012	Magnet	1
8	72T9-007	Screw driver (long)	1
9	72T9-020	Screw driver (medium)	1
10	72T9-021	Screw driver (short)	1
11	72T9-022	Double-end wrench	1
12	22T9-017	Oil container	1
13	22T9-018	Vinyl cover	1
14	DP × 17 22#	Needle	4

12

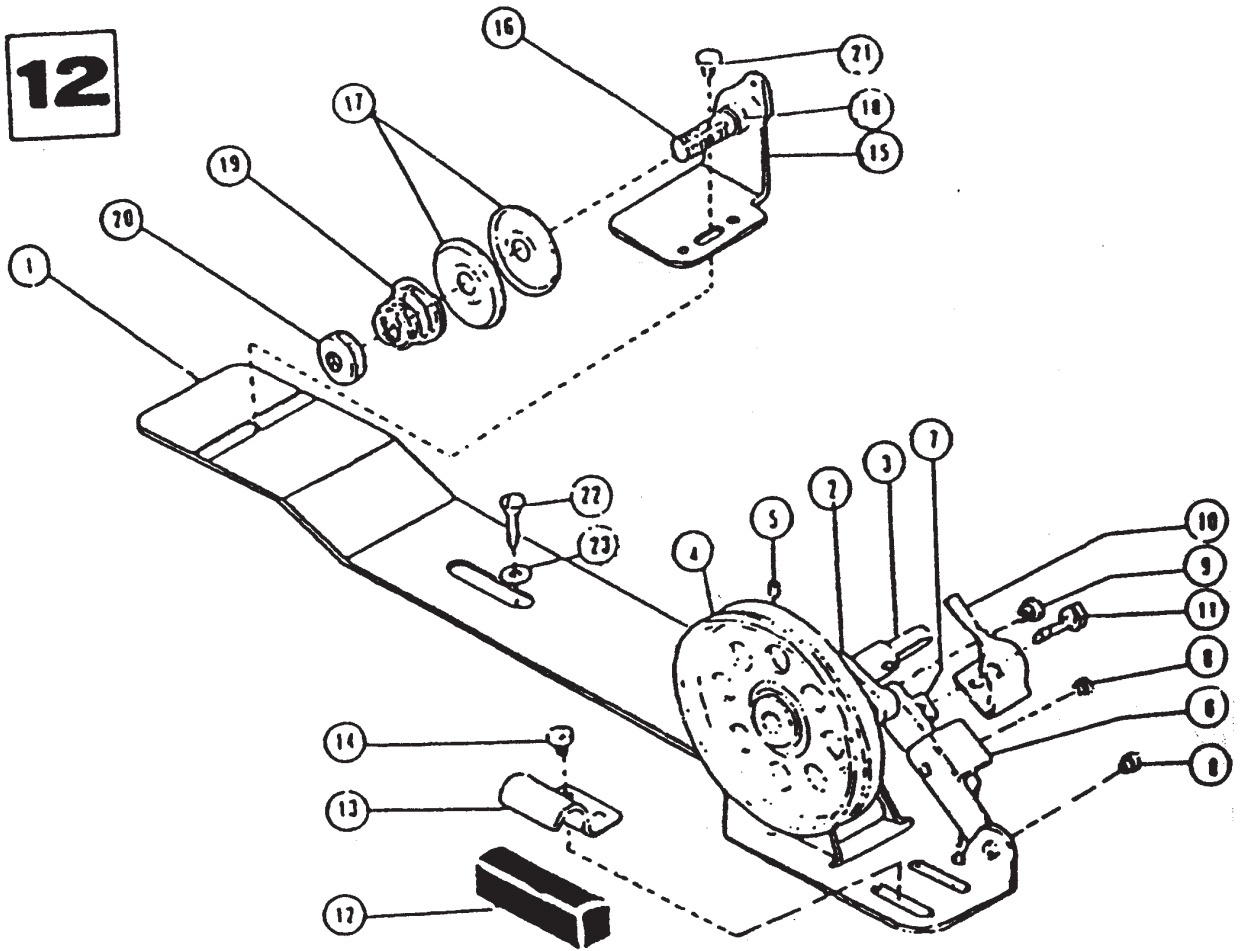



## 12. BOBBIN WINDER MECHANISM

No.	Ref No	Description	Pieces
1	22T9-006D1	Bobbin winder base	1
2	22T9-006D2	Bobbin winder arm	1
	22T9-006D3	Shaft for bobbin winder arm	1
	22T9-006D4	Spring	1
3	22T9-006D5	Bobbin winder spindle	1
4	22T9-006D6	Bobbin winder pulley	1
5	22T9-006D7	Screw	1
6	22T9-006D8	Bobbin winder stop latch lever	1
7	22T9-006D9	Bobbin winder connecting bar	1
8	22T9-006D10	Rivet	2
9	22T9-006D11	Screw	1
10	22T9-006D12	Bobbin winder stop latch	1
11	22T9-006D13	Adjusting screw	1
12	22T9-006D14	Stopper block	1
13	22T9-006D15	Fixture for stopper block	1
14	22T9-006D16	Set screw	1
15	22T9-006D17	Bobbin winder tension bracket	1
16	22T9-006D18	Bobbin winder tension stud	1
17	22T9-006D19	Bobbin winder tension disc	2
18	22T9-006D20	Tension stud bushing	1
19	22T9-006D21	Bobbin winder tension spring	1
20	22T9-006D22	Tension stud nut	1
21	22T9-006D23	Tension bracket screw	1
22		Wood screw	2
23		Washer	2