

Bisherige Form Previous form 
 Geänderte Form Modified form 

adler Berichtigung der Ersatzteillisten
 Amendment of spare parts lists
 Klasse Class **104,**
 Änderung: Schaukelwelle
 Rocker shaft modification

064 00 171 3 (104-2,-VN2,-VN2S,-64,105 und 504)
 066 00 171 3 (104-102,-102SF,-WS102S,-103,-4102S und 166-1,-102,-3102,-302)
 992 01 435 0
 992 00 555 0
 005 00 063 0 996 07 011 8
 104 15 003 4 (104-2,-VN2,-VN2S,-64,105 und 504)
 166 15 005 4 (104-102,-102SF,-WS102S,-103,-4102S und 166-1,-102,-3102,-302)

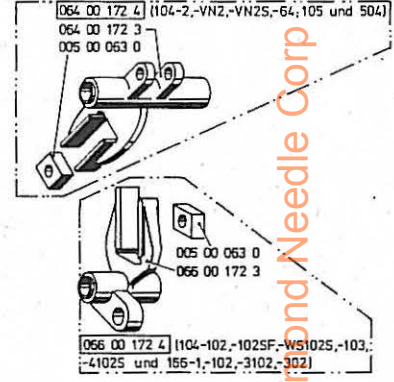

Klasse 104

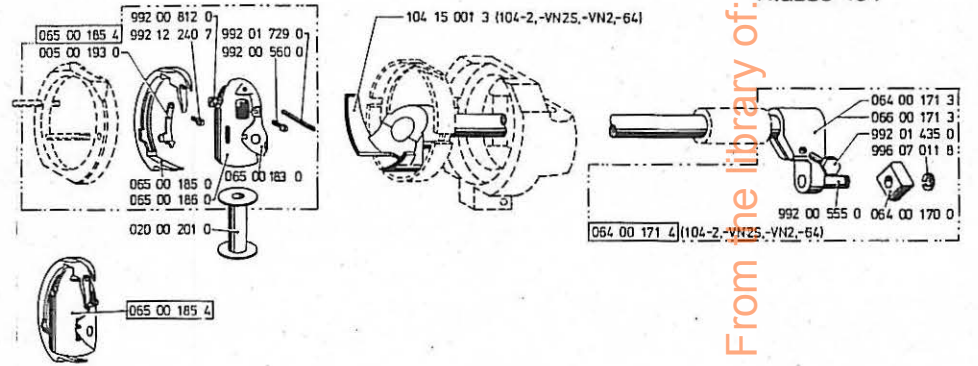

From the library of: Diar and Needle Corp

adler 104-VN2;-VN2S

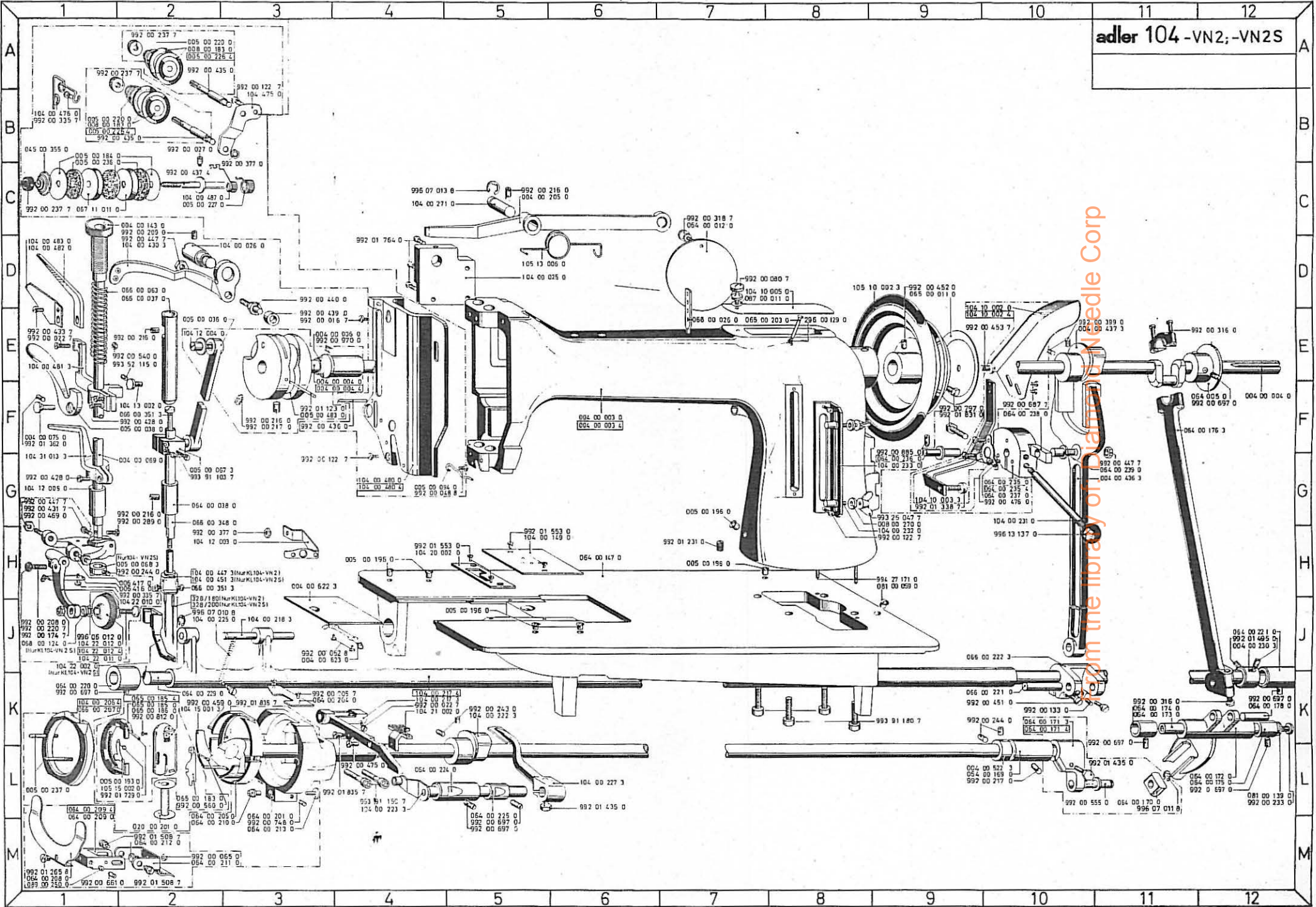

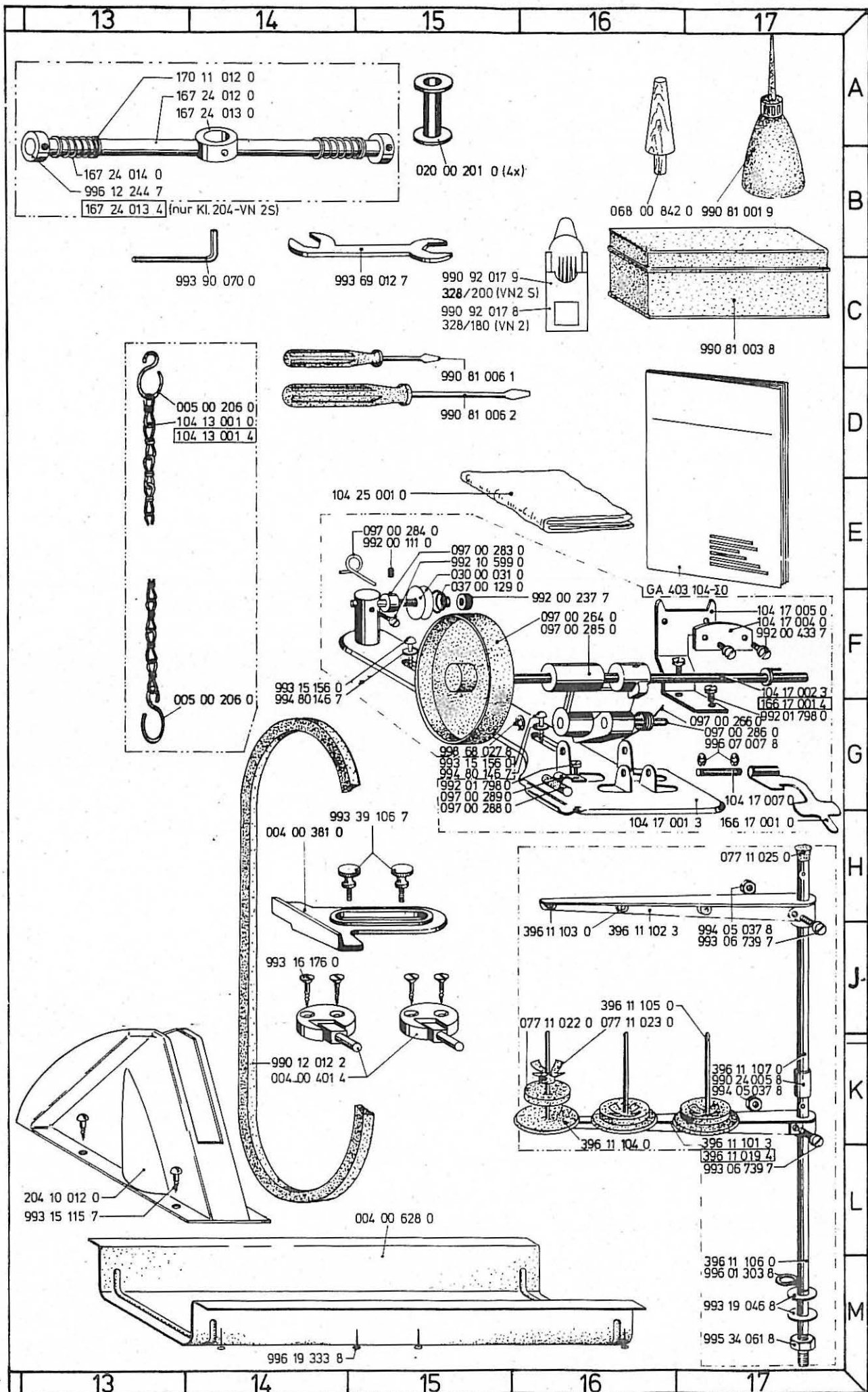

A
B
C
D
E
F
G
H
J
K
L
M

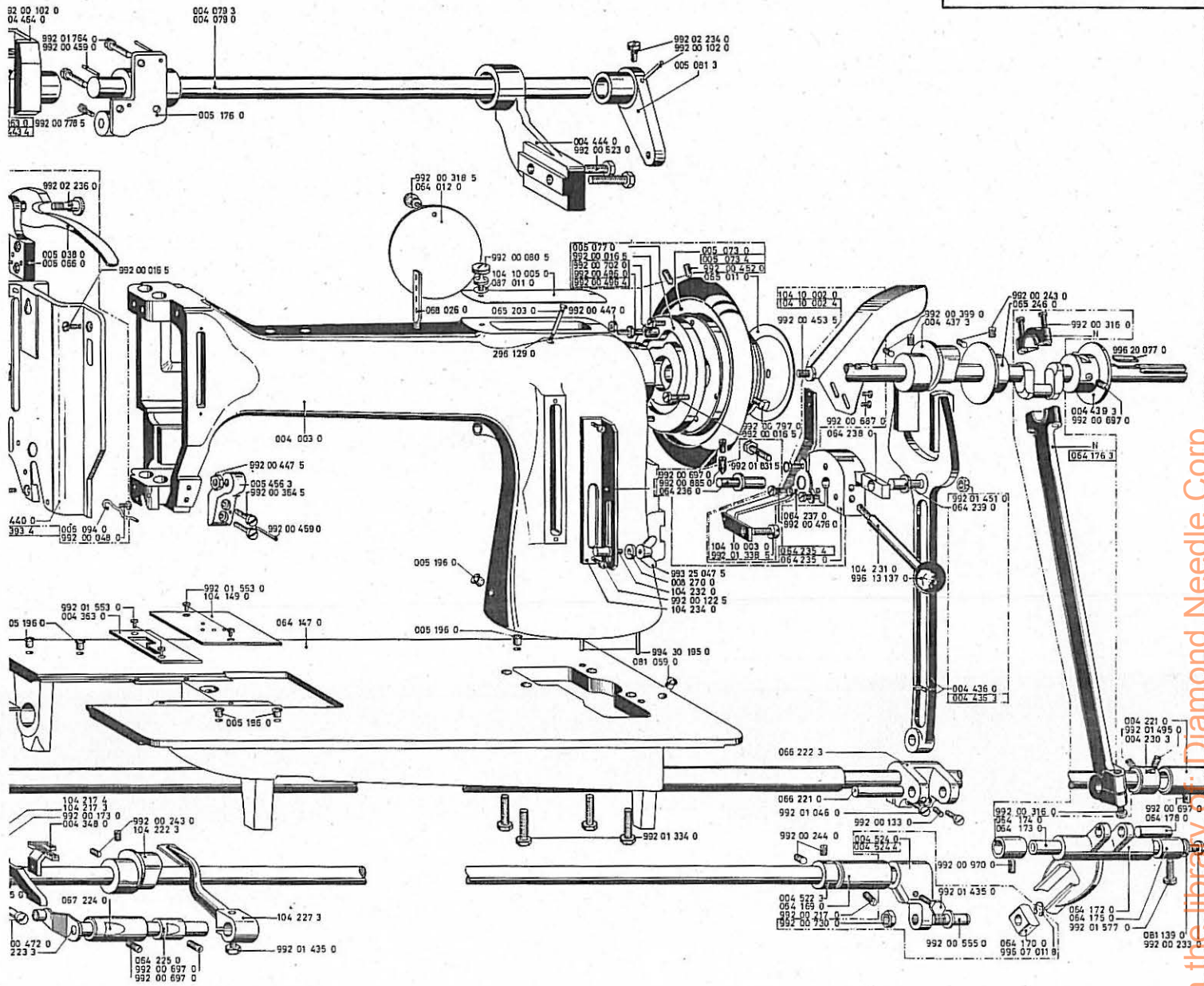

From the library of Diamond Needle Corp

13

14

15

16

17

Benennung

A

B

C

D

E

F

G

H

J

K

L

M

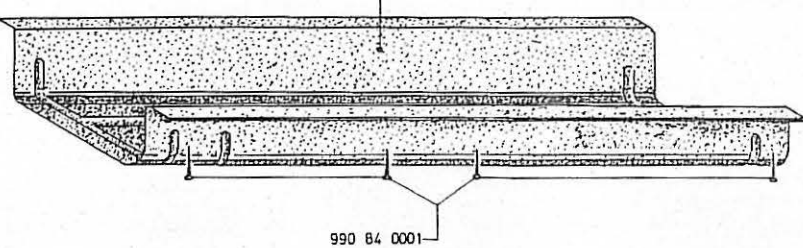
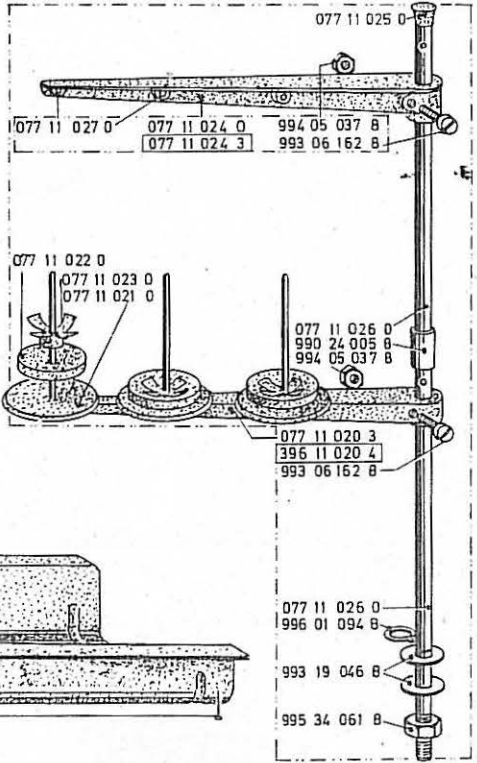
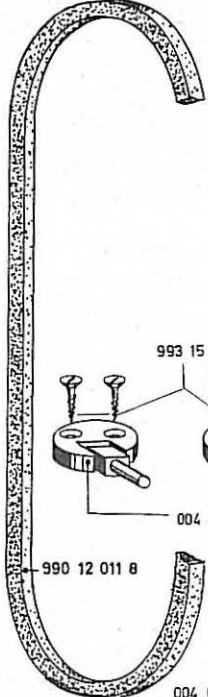
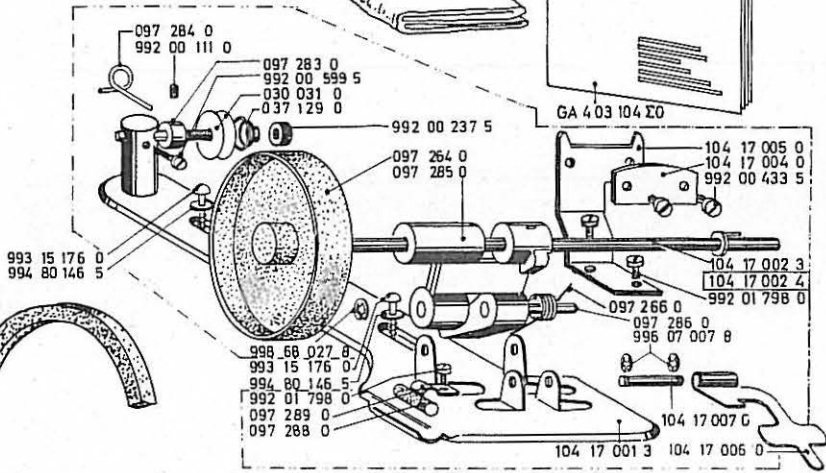
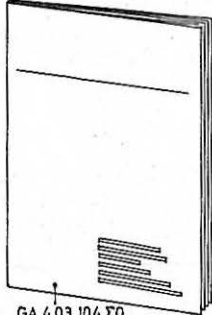
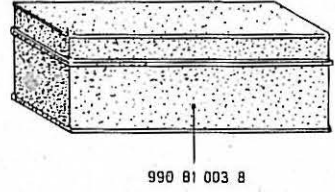
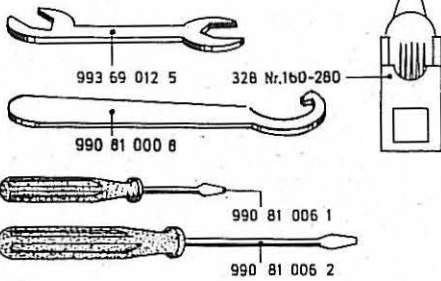
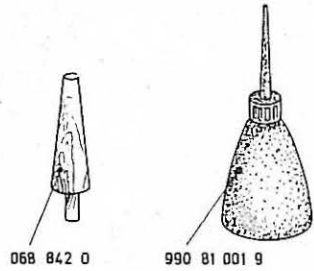

13

14

15

16

17

From the library of: Diamond Needle Corp

adler 104-64

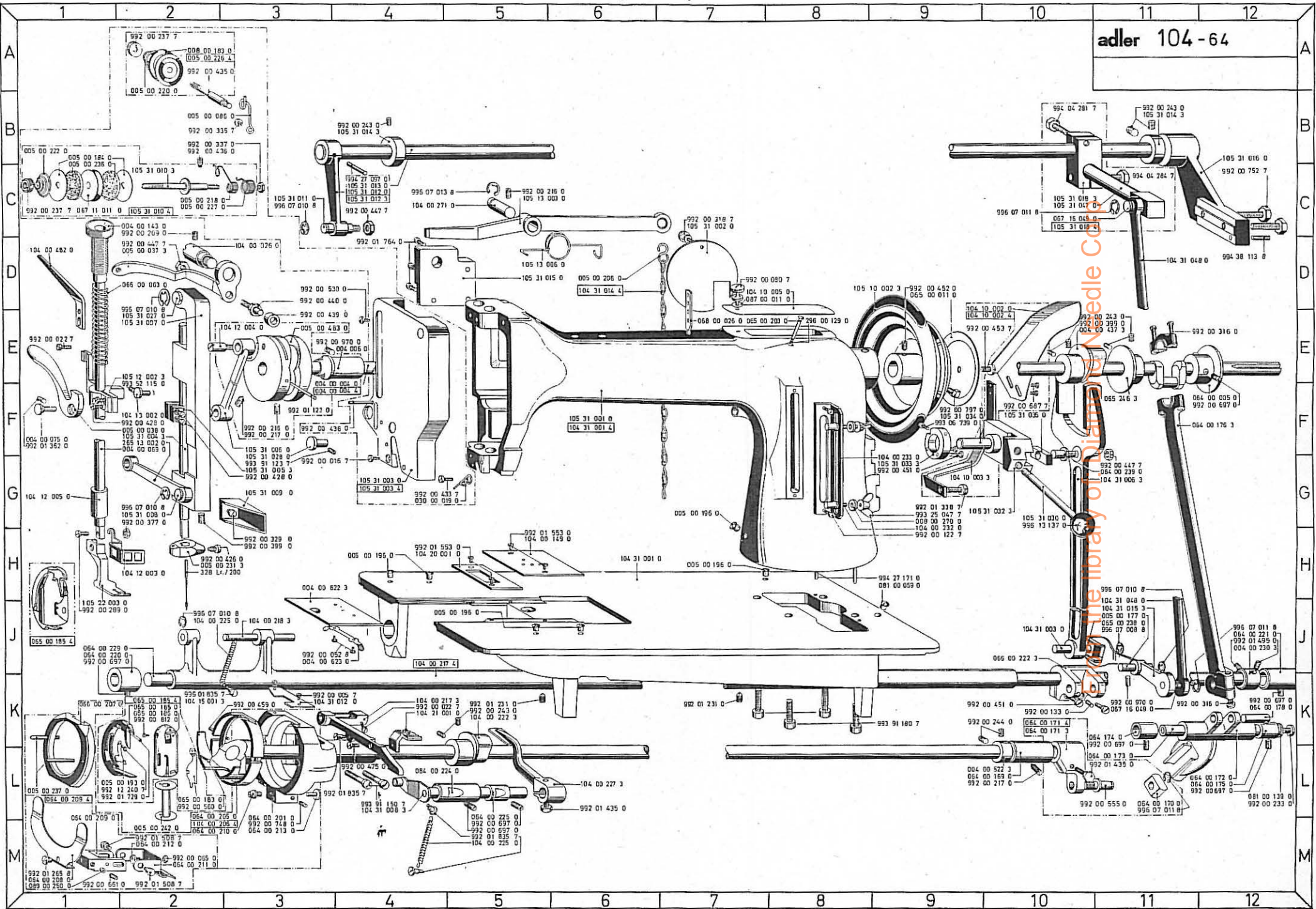

13

14

15

16

17

A
B
C
D
E
F
G
H
J
K
L
M

Teil-N

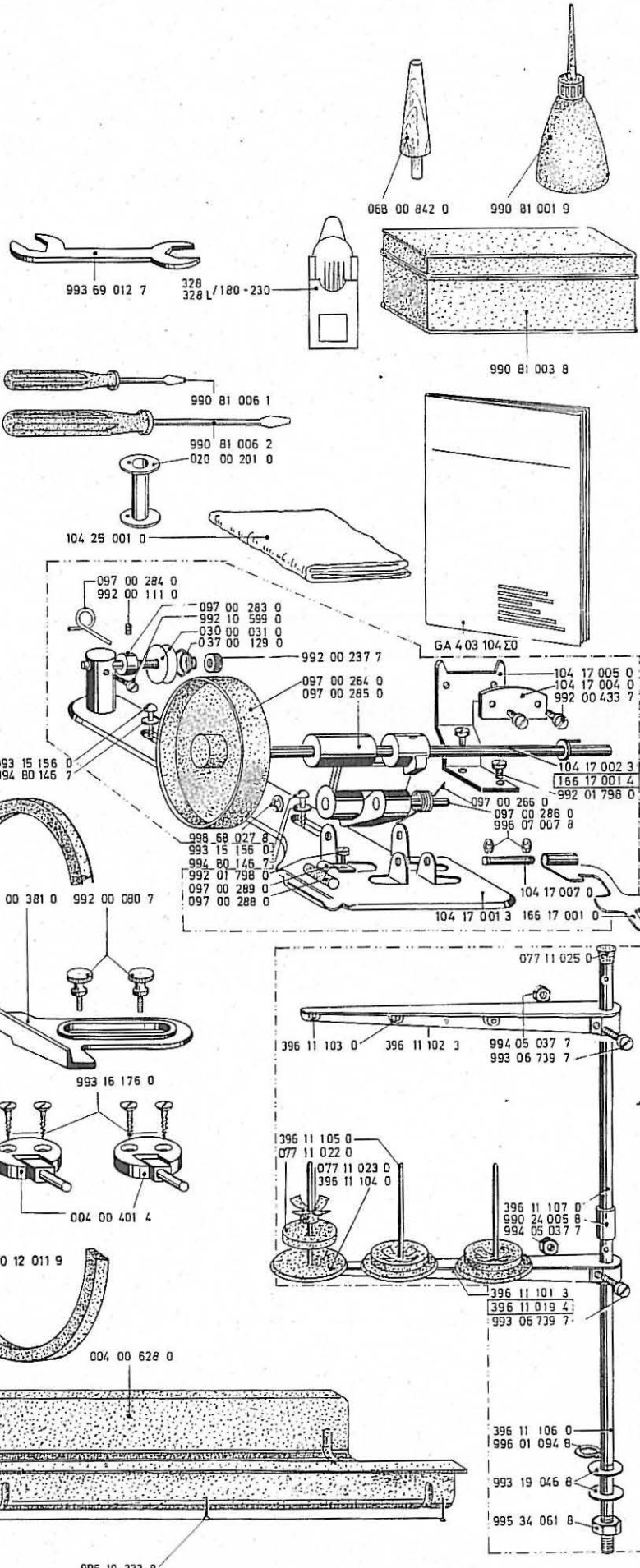

From the library of: Diamond Needle Corp

13

14

15

16

17

adler 104-102

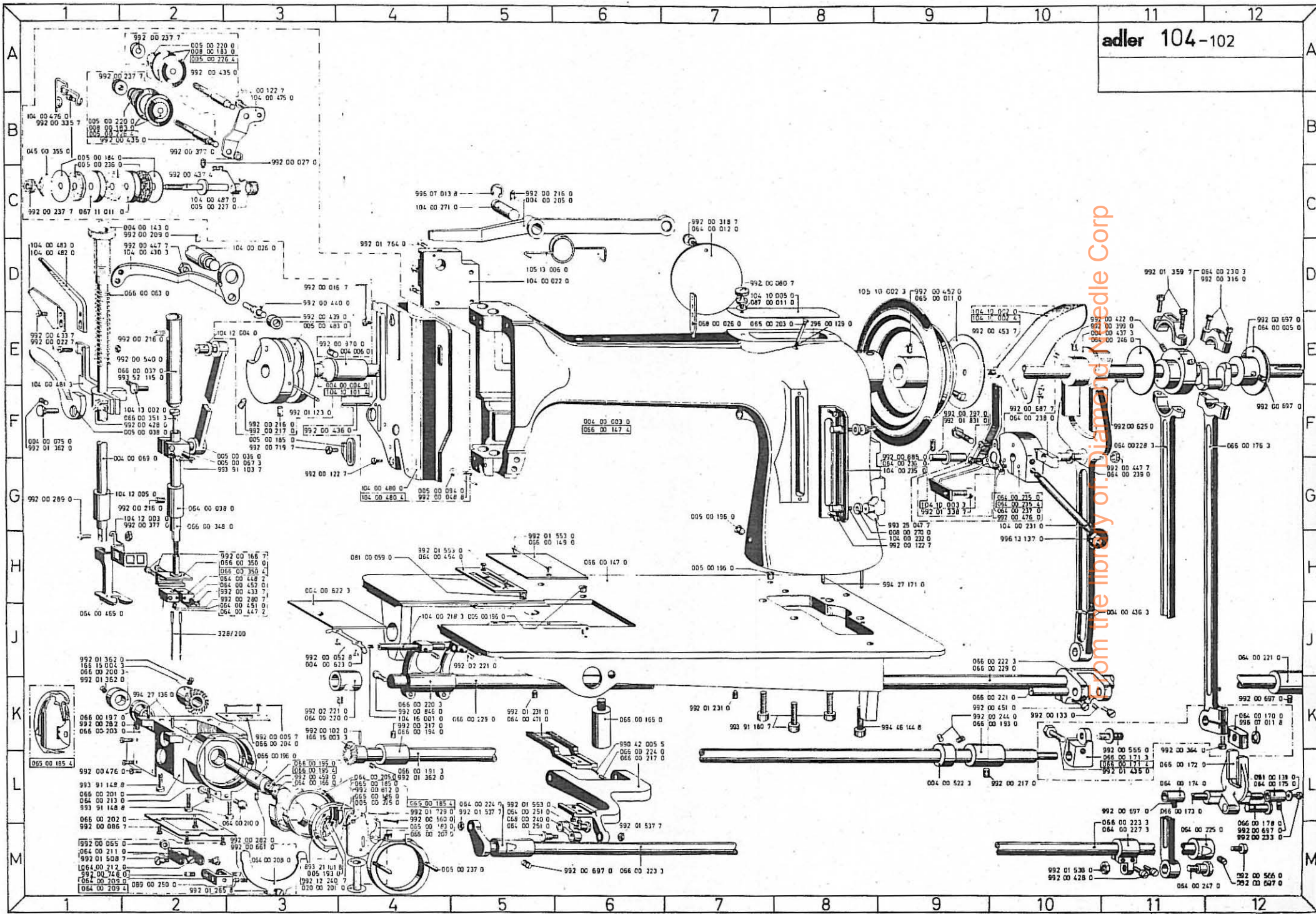

13

14

15

16

17

A

B

C

D

E

F

G

H

J

K

L

M

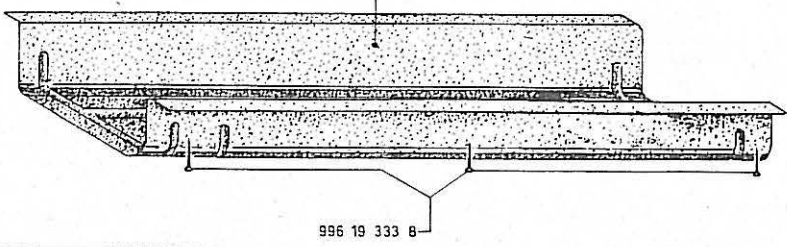
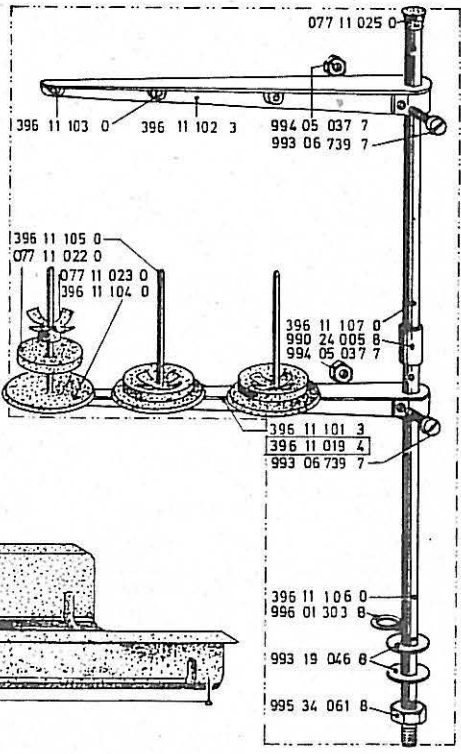
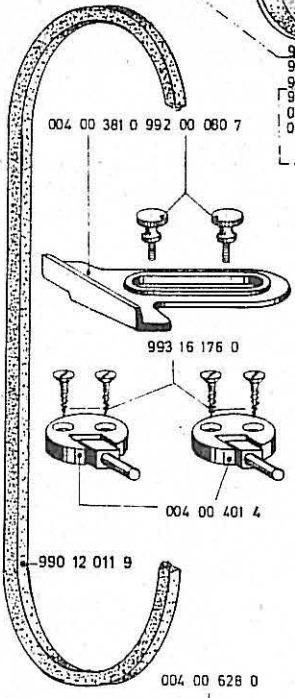
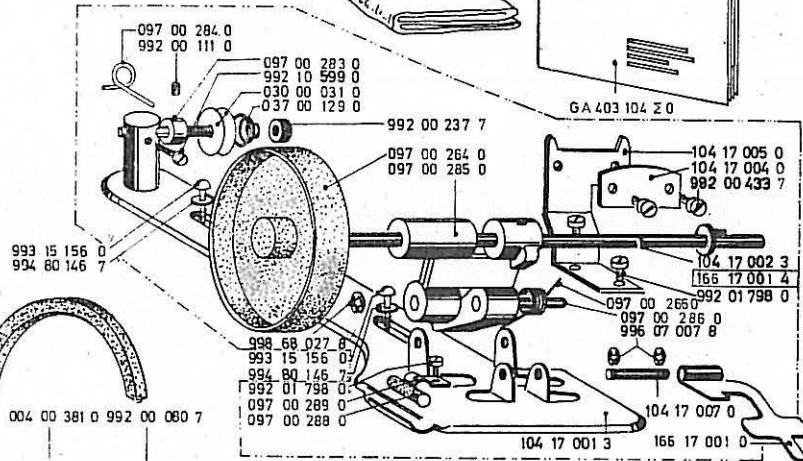
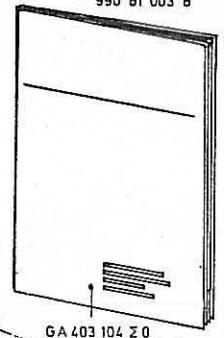
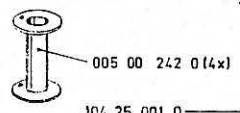
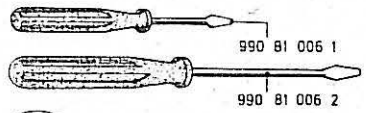
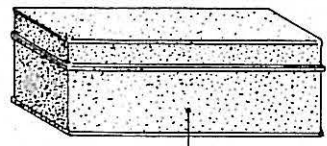
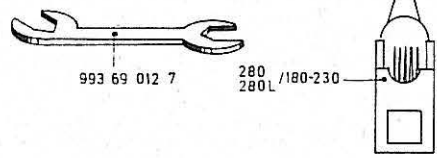
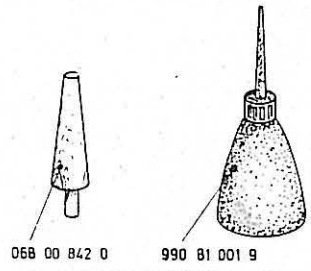

13

14

15

16

17

From the library of: Diamond Needle Corp

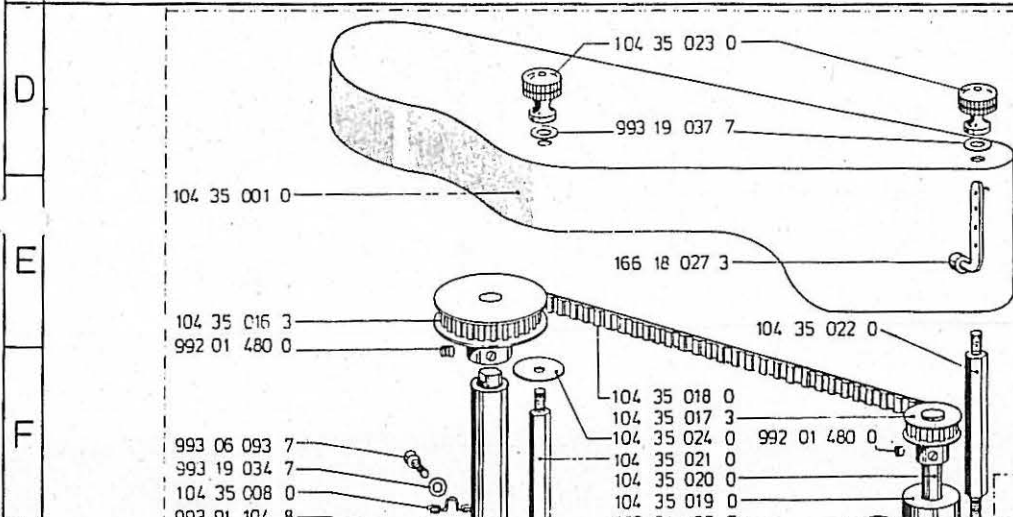
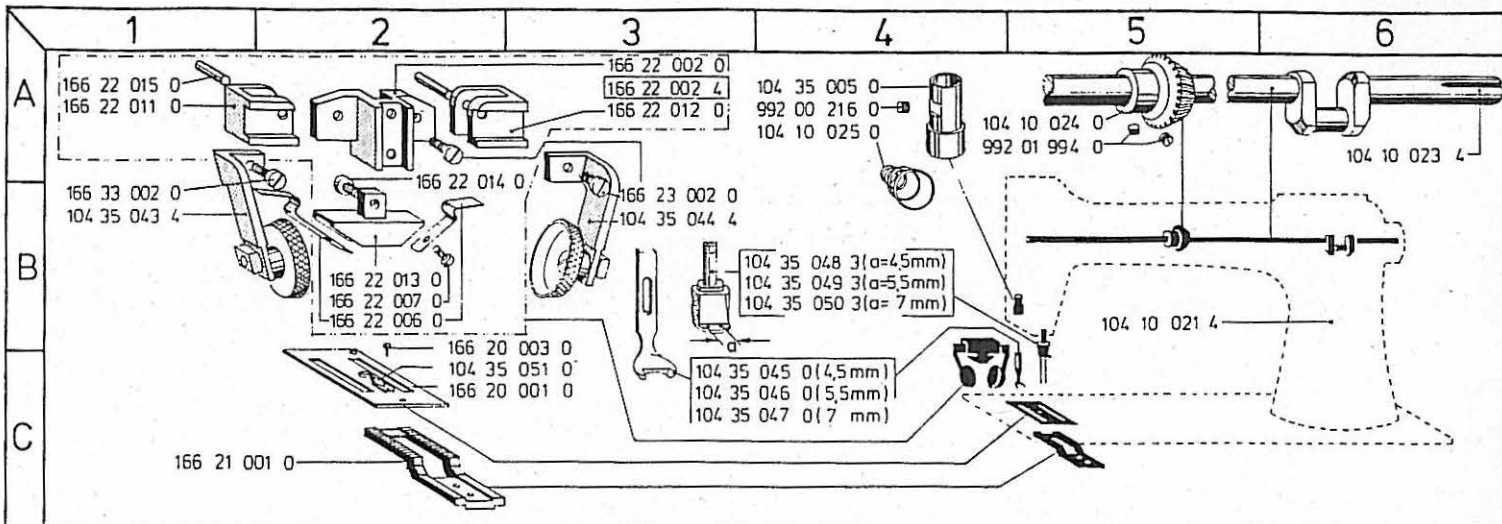

Zusatzblatt
für Klasse
adler 104WS-102S

Hier sind die Teile aufgeführt die in der Ersatzteilliste der Klasse 104-4102S geändert bzw. hinzu gefügt wurden, um die Klasse 104WS-102S zu bilden.

Amendment to parts list Cl. 104-4102S which form Cl. 104WS-102S, showing the modified parts.

Interims Ersatzteilliste
Provisional Spare Parts List
Liste provisoire de pièces de rechange

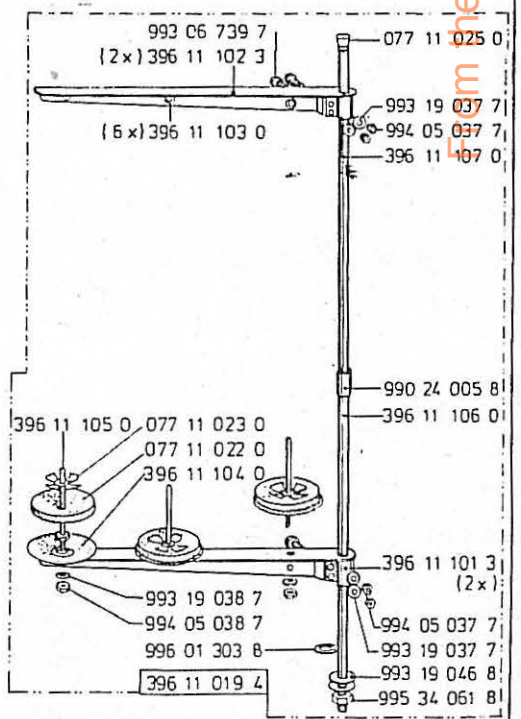
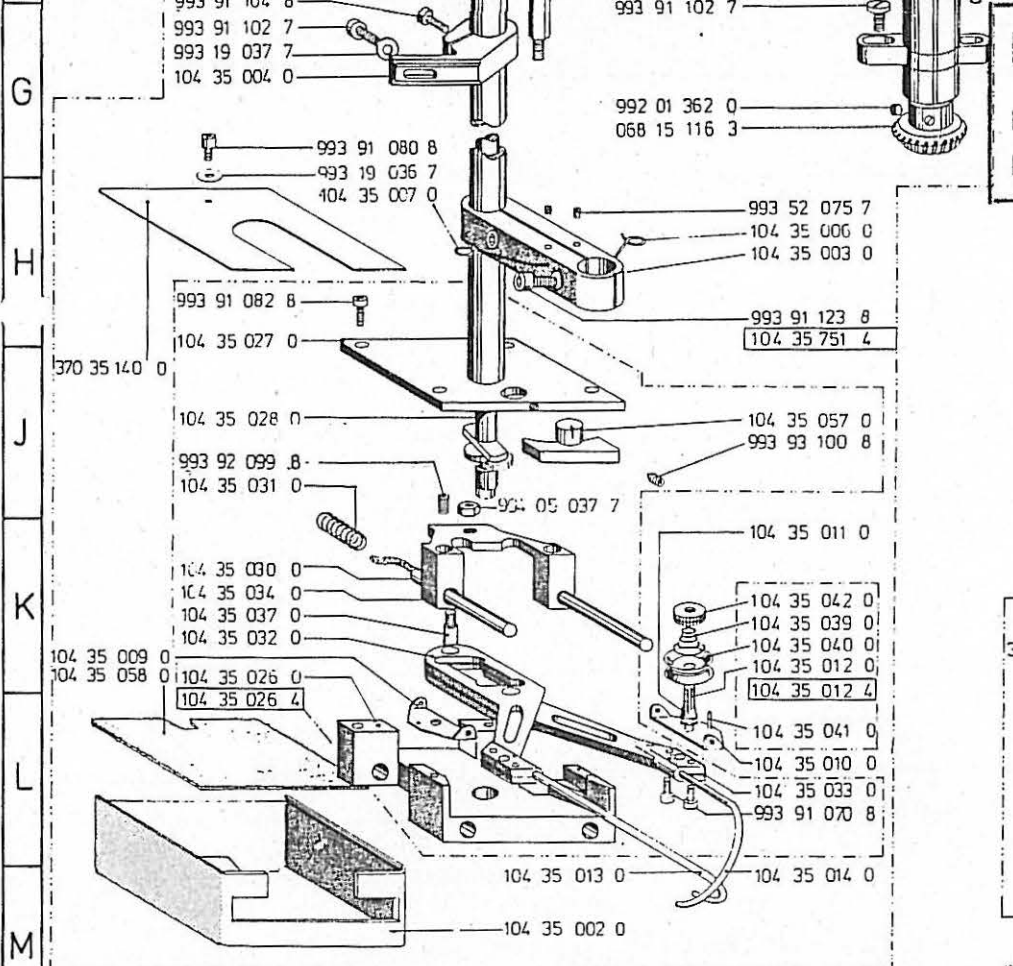

aus Klasse 104-4102S

adler 104WS-102S

Verschleißteilleiste

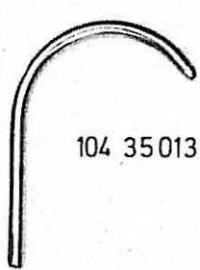

104 35 0130

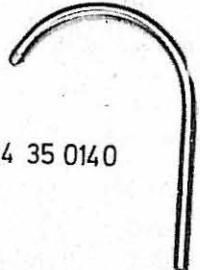

104 35 0140

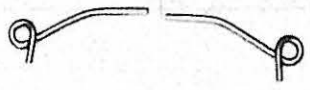

104 35 0070 104 35 0060



104 23 0020

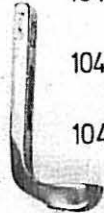

104 35 0450 (4,5 mm)

104 35 0460 (5,5 mm)

104 35 0470 (7 mm)

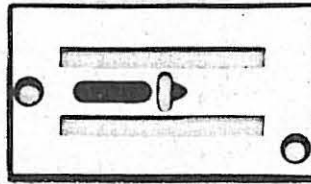

166 20 0010



104 35 0510



166 20 0030

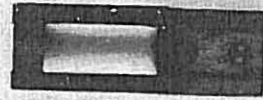

166 21 0010

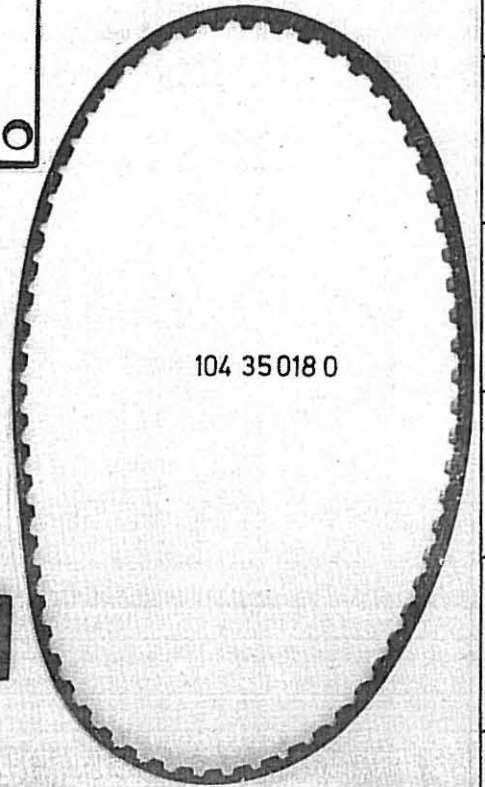

104 35 0180

From the library of: Diamond Needle Corp

Teil - Nr.	Benennung		Teil - Nr.	Benennung
104 23 002 0	Rollfuß-Schraube	C 1		
104 35 006 0	Fadenführungs-Öse, rechts	A 4		
104 35 007 0	Fadenführungs-Öse, links	A 3		
104 35 013 0	Fadenvorleger, links	B 1		
104 35 014 0	Fadenvorleger, rechts	B 2		
104 35 018 0	Gurt	D 5		
104 35 045 0	Nadelführung, 4,5 mm	C 2		
104 35 046 0	Nadelführung, 5,5 mm	D 2		
104 35 047 0	Nadelführung, 7 mm	D 2		
104 35 051 0	Stichpl.-Finger	D 4		
166 20 001 0	Stichplatte C 4	C 4		
166 20 003 0	Zylinderschraube (für Stichpl.-Finger)	E 4		
166 21 001 0	Transporteur	F 4		

adler 104-4102 S

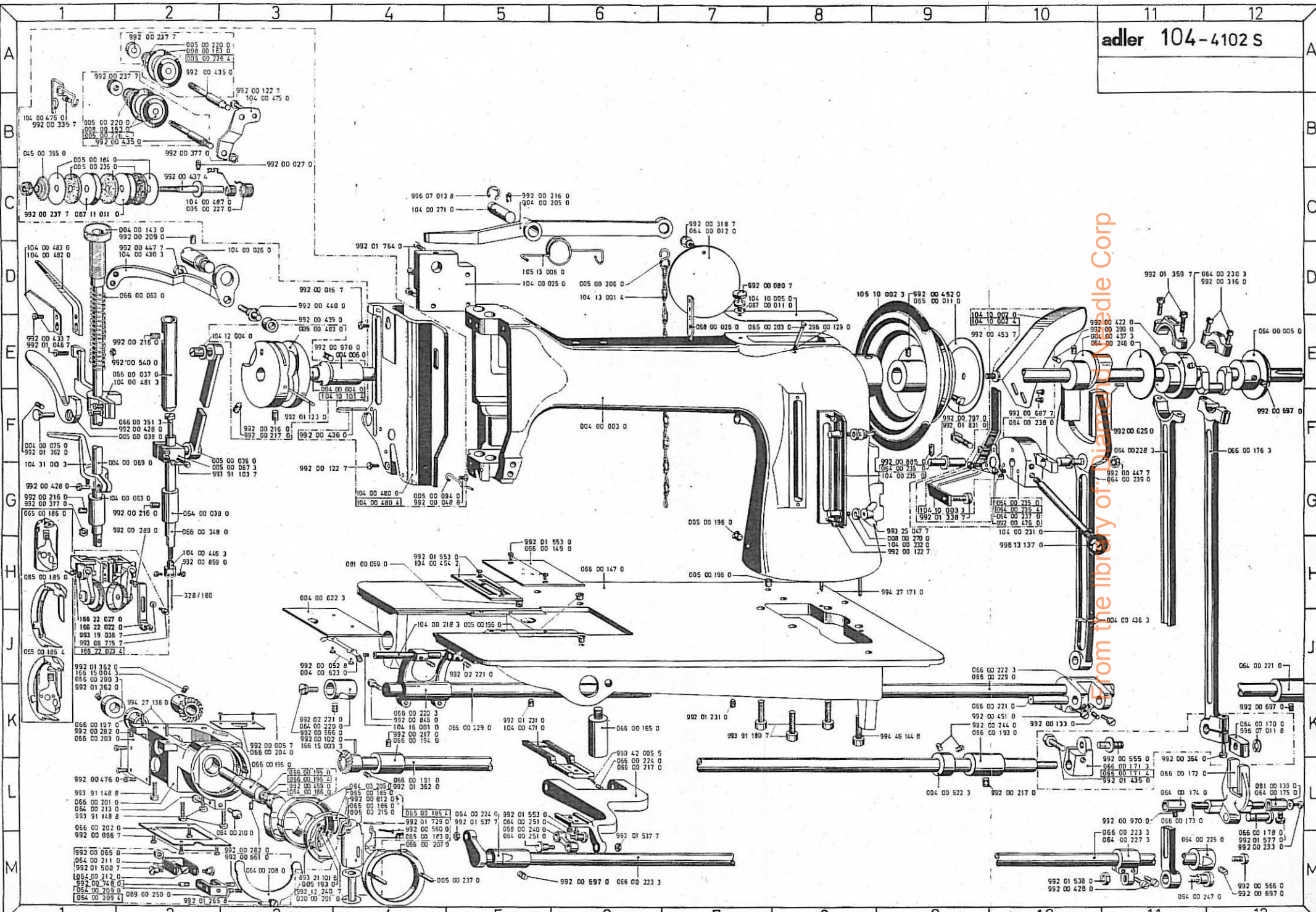

nung Teil-Nr.

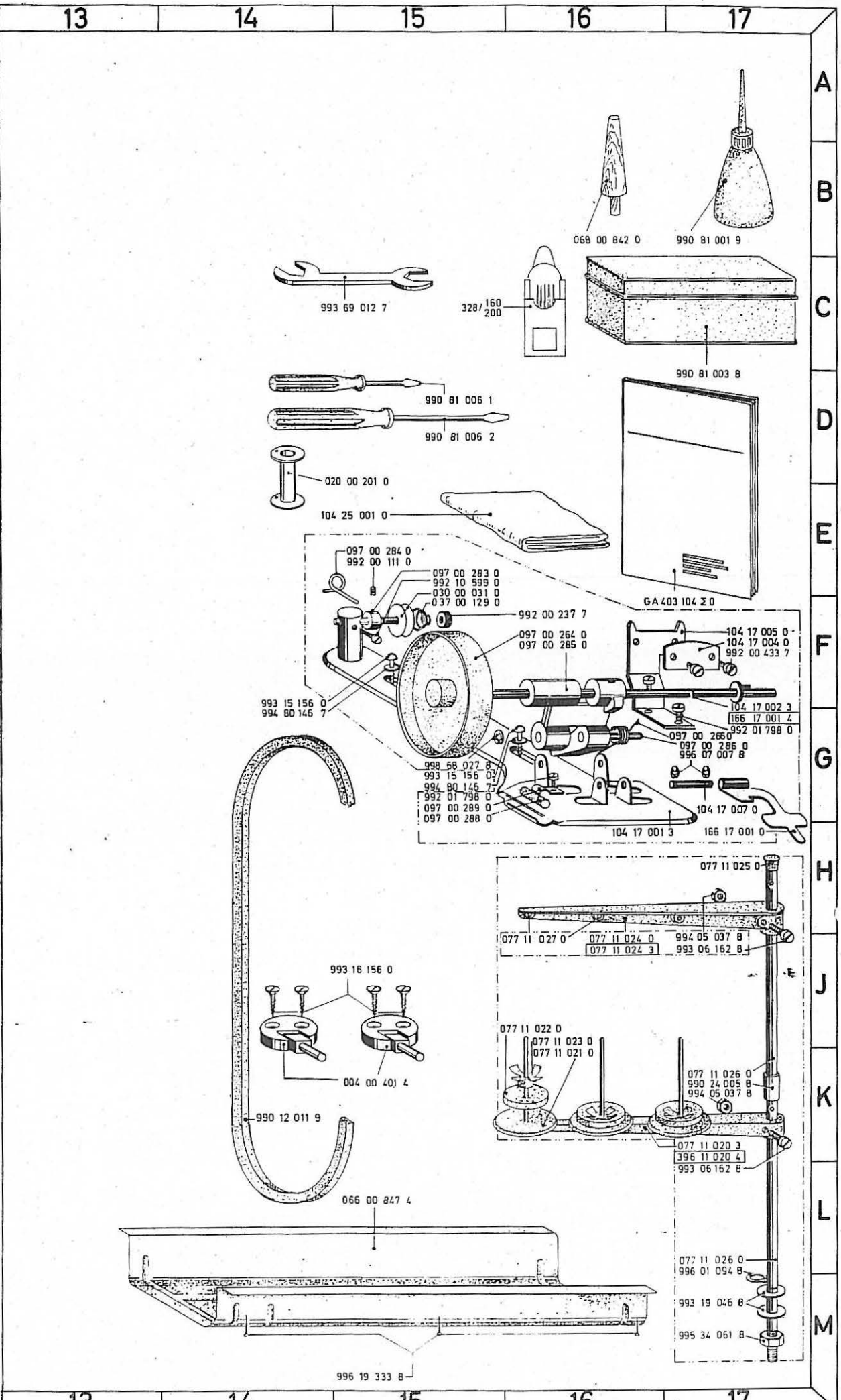

From the library of: Diamond Needle Corp

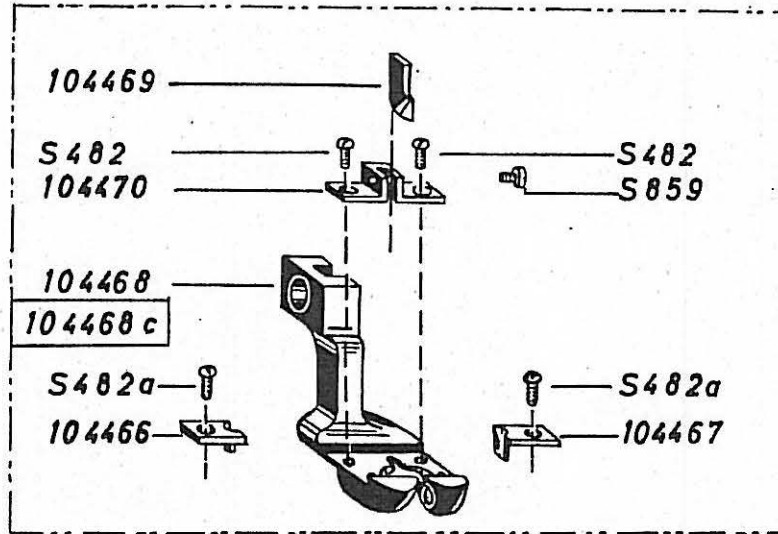

Ritzfuß

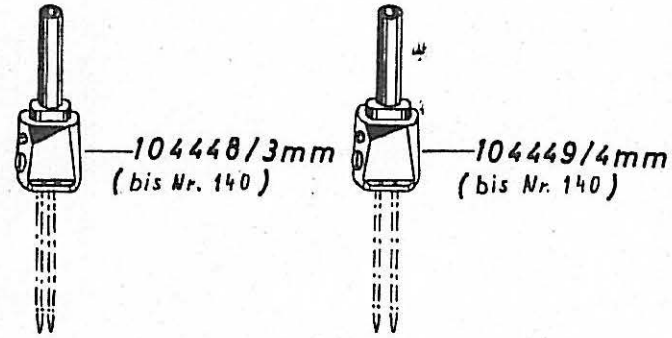

From the library of: Diamond Needle Corp

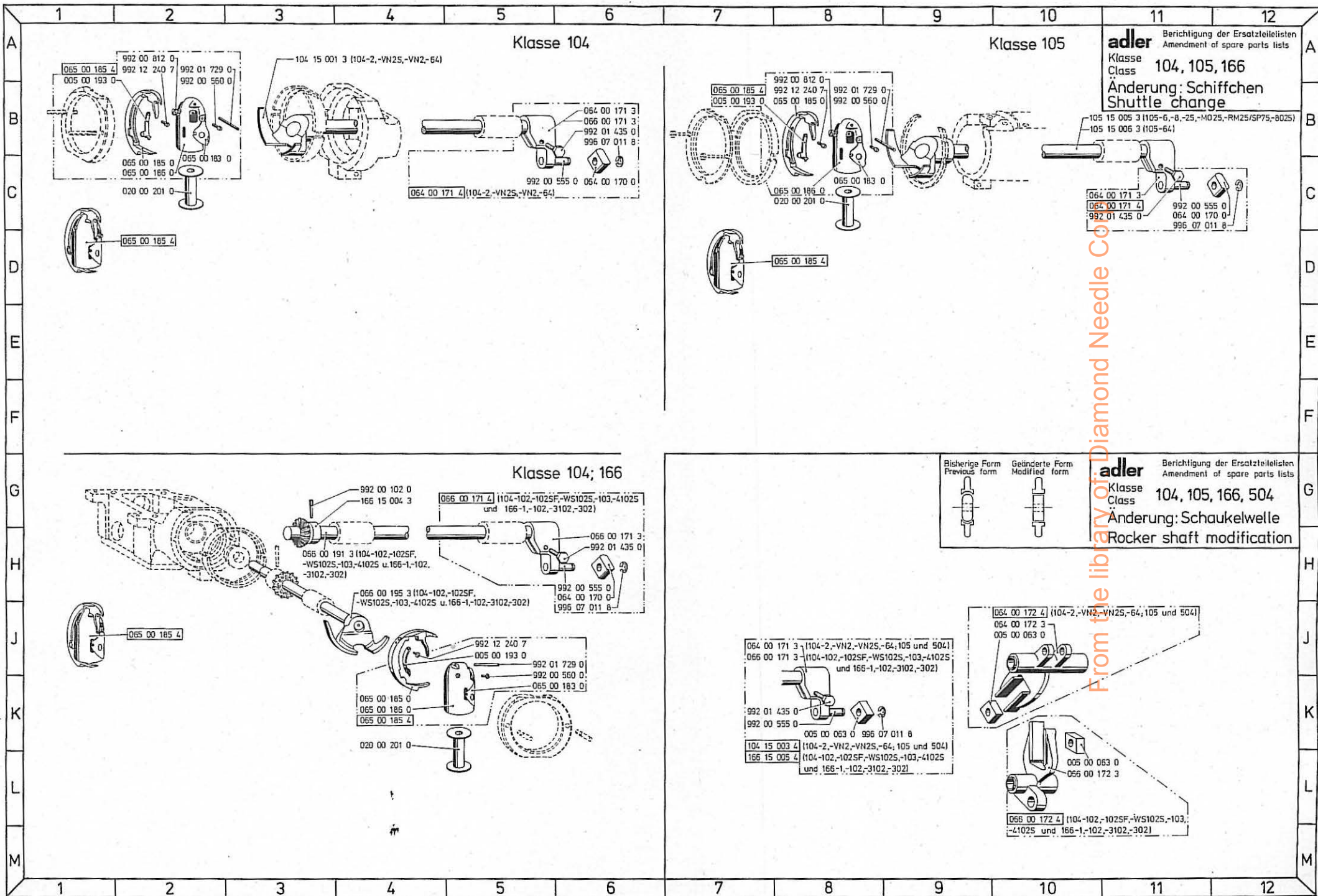

adler Berichtigung der Ersatzteillisten
Amendment of spare parts lists
Klasse Class 104, 105, 166
Änderung: Schiffchen
Shuttle change

adler Berichtigung der Ersatzteillisten
Amendment of spare parts lists
Klasse Class 104, 105, 166, 504
Änderung: Schaukelwelle
Rocker shaft modification

From the library of Diamond Needle Co

