

868

Additional Instructions

Assembling the tape guide

IMPORTANT
READ CAREFULLY BEFORE USE
KEEP FOR FUTURE REFERENCE

All rights reserved.

Property of Dürkopp Adler GmbH and protected by copyright. Any reuse of these contents, including extracts, is prohibited without the prior written approval of Dürkopp Adler GmbH.

Copyright © Dürkopp Adler GmbH 2020

1	Components of the kit.....	3
2	Assembling the kit.....	4

1 Components of the kit

Check whether the scope of delivery for the kit is correct prior to assembling the tape guide. Different kits are available that vary with the width of the tape. The installation procedure is the same for all kits.

Kit	Tape width
N522 025021	14 mm
N522 025031	16 mm
N522 025041	18 mm
N522 025051	20 mm

Components of the kit

Part no.	Number	Description
N522 005009	1	Guide
N522 005024/ N522 005034/ N522 005044/ N522 005054	1	Tape guide 14 mm 16 mm 18 mm 20 mm
N522 005025/ N522 005035/ N522 005045/ N522 005055	1	Tape insert 14 mm 16 mm 18 mm 20 mm
N522 005026/	1	Regulating washer
0992 023980	1	Screw M3x2.8
0992 009580	1	Screw no. 89x4
0992 023677	1	Screw M4x4,3
N522 005007	1	Flap
N522 005006	1	Guide
9203 003667	2	Screw M4x10
9203 003657	1	Screw M4x8
9330 000087	2	Washer A4.3
9330 200097	2	Washer A4.3
N522 005008	1	Plate
9207 150147	2	Screw 3.0x16
9207 160347	2	Screw 3.0x16
N900 001527	1	Tape roll holder
N900 001601	1	Tape roll holder

2 Assembling the kit

WARNING



Risk of injury from moving, sharp parts!

Puncture and crushing possible.

Switch off the machine before assembling the kit.

WARNING



Risk of injury from heavy parts!

Crushing possible.

Make sure that your hands do not reach under the machine.

Fig. 1: Removing the slot

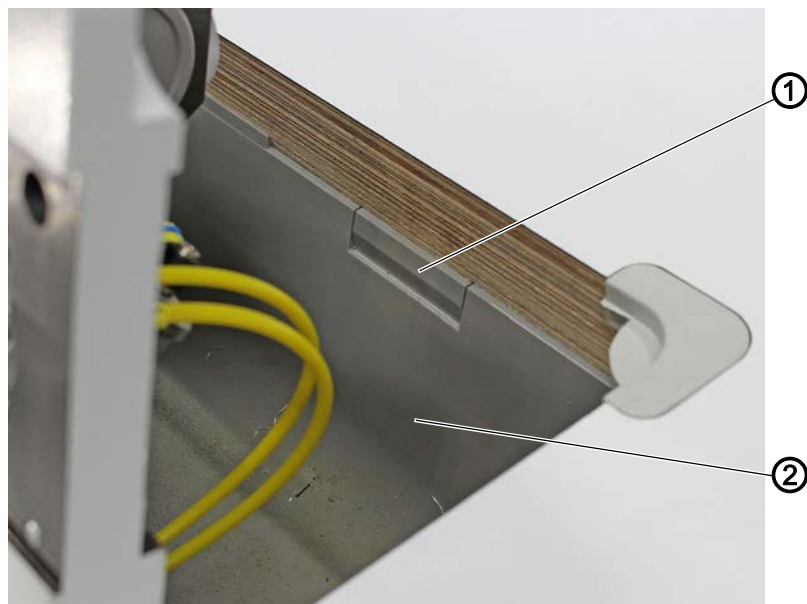

(1) - Piece of plastic

(2) - Oil pan



1. Before installing the oil pan (2), remove the piece of plastic (1) so as to create a slot.

Fig. 2: Fixing the guide in place at the tabletop



- | | |
|---------------|----------------|
| (3) - Slot | (4) - Guide |
| (2) - Oil pan | (5) - Tabletop |



- Fix the guide (4) in place at the tabletop (5) in such a way that it is seated in the slot (3) of the oil pan (2); if necessary, pre-drill 2 mm into the tabletop to prepare the holes.

Fig. 3: Pre-assembling the tape guide

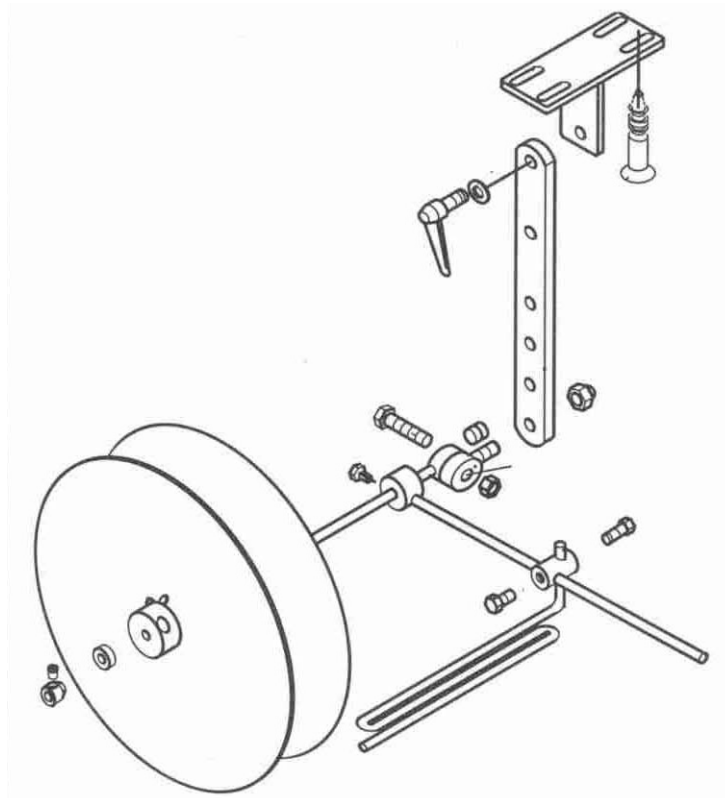

- Pre-assemble the tape guide as shown above.

Fig. 4: Assembling the tape guide at the tabletop

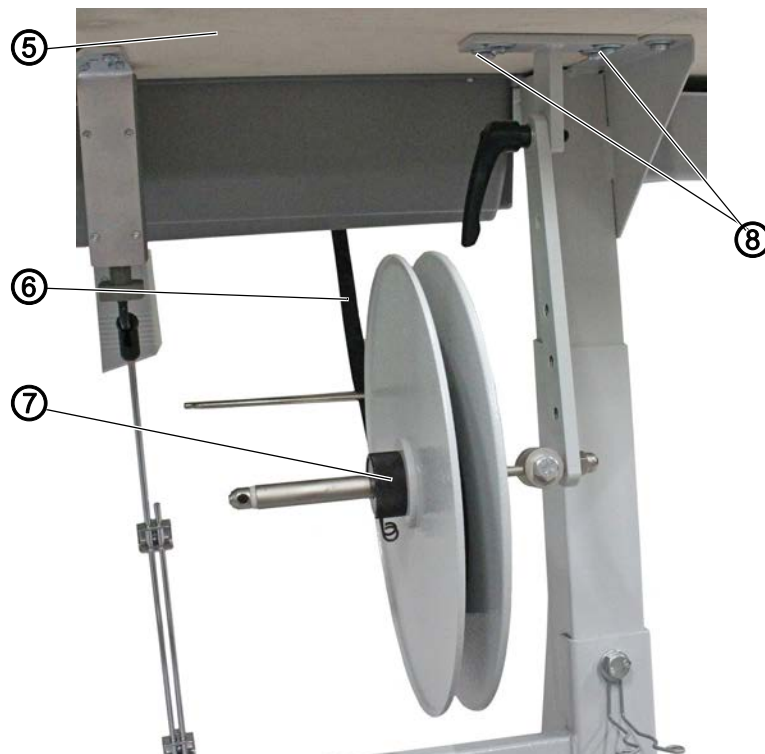

(5) - Tabletop
(6) - Tape

(7) - Tape guide
(8) - Screws (4x)



- Use screws (8) to fix the tape guide (7) in place at the tabletop (5) in such a way that the tape (6) is positioned at the center of the needle.

Fig. 5: Assembling guides

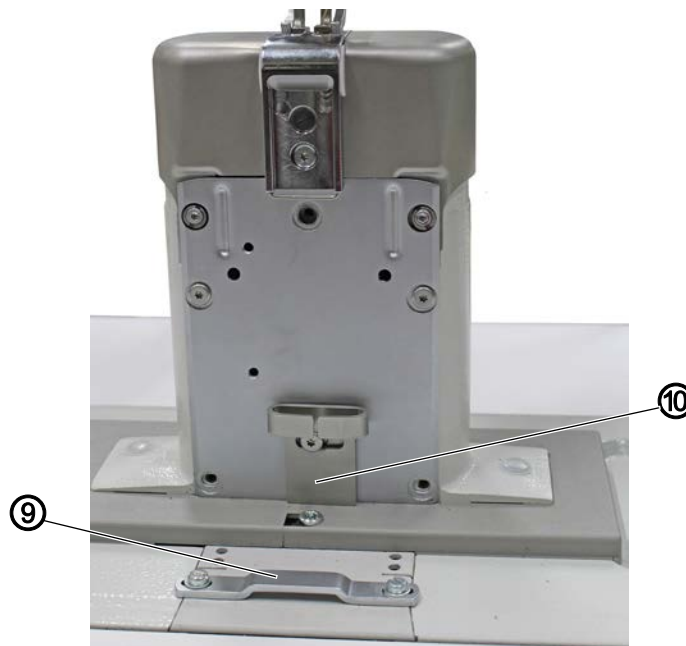

(9) - Guide

(10) - Guide



- Fix the guide (9) in place using washers and screws.
- Fix the guide (10) in place using the screw.

Fig. 6: Pre-assembling the guide



(11) - Spacer piece
(12) - Screw

(13) - Guide
(14) - Tape insert



7. Assemble the spacer piece (11) with the screw (12) on the guide (13).
8. Clamp the tape insert (14) into the guide (13).

Fig. 7: Assembling the guide

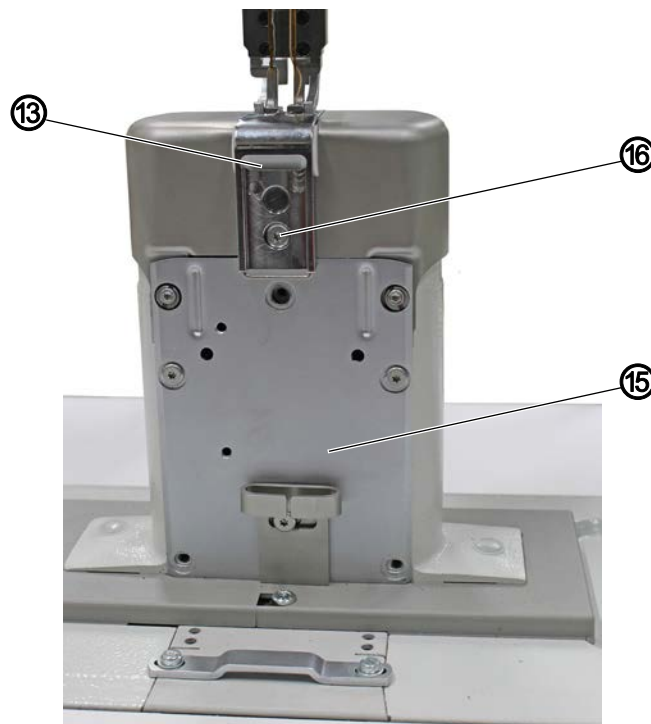

(13) - Guide
(15) - Plate

(16) - Screw



9. Fix the guide (13) in place using the screw (16). If screw (16) and hole do not line up on top of each other, loosen the entire plate (15) again and align it properly.

Fig. 8: Threading the tape



10. Thread the tape as shown in the figure. The tape must be guided to the needle without twisting.



Information

If the tape does not pass without resistance between base plate and tabletop, CAREFULLY file off a small portion of the tabletop.



DÜRKOPP ADLER GmbH
Potsdamer Str. 190
33719 Bielefeld
Germany
Phone: +49 (0) 521 925 00
Email: service@duerkopp-adler.com
www.duerkopp-adler.com