

261

操作说明

Operating Instructions

零件列表

Parts List



非常感谢您购买本公司的工业缝纫机。在使用缝纫机之前，请仔细阅读（为了您的安全使用）和使用说明书。

工业缝纫机的特性之一，是要在机针和旋梭等运动零部件附近进行操作，而这些零部件很容易引起受伤的危险，所以请在受过培训的人员或有熟练操作技术的人员的指导下，正确地使用本缝纫机。



# 为了您的安全使用

## 1. 安全使用的标记及其意义

本使用说明书及产品所使用的标记和图案记号是为了您的安全而正确地使用本产品，防止您及他人受到危害和损害。

表示方法及含义如下：

### 说明

	<b>危险</b>	如果忽视此标记而进行了错误的操作，必将导致人员死亡或重伤。
	<b>注意</b>	如果忽视此标记而进行了错误的操作，有可能会引起人员受伤及造成设备损坏。
	<b>警告</b>	如果忽视此标记而进行了错误的操作，将会引起人员重伤或死亡。

### 图案和符号



符号△表示“应注意事项”。  
三角中的图案表示必须要注意的内容。  
(如左图的符号表示“注意受伤”。)



符号⊘表示“禁止”。



符号●表示“必须”。  
圆圈中的图案表示必须要做的内容。  
(如左图的符号表示“必须接地”。)

Thank you very much for buying our sewing machine. Before using your new machine, please read the safety instructions below and the explanations given in the Operation Instruction.



With industrial sewing machines, it is normal to carry out work while positioned directly in front of moving parts such as the needle and thread take-up lever, and consequently there is always a danger of injury that can be caused by these parts. Follow the instructions from training personnel and instructors regarding safe and correct operation before operating the machine so that you will know how to use it correctly.

## SAFETY INSTRUCTIONS

### 1. Safety indications and their meanings

This instruction manual and the indications and symbols that are used on the machine itself are provided in order to ensure safe operation of this machine and to prevent accidents and injury to yourself or other people. The meaning of these indications and symbols are given below.

#### Indications

	<b>DANGER</b>	The instructions which follow this term indicate situations where failure to follow the instructions will almost certainly result in death or severe injury.
	<b>CAUTION</b>	The instructions which follow this term indicate situations where failure to follow the instructions could cause injury when using the machine or physical damage to equipment and surroundings.
	<b>CAUTION</b>	The instructions which follow this term indicate situations where failure to follow the instructions will almost certainly result in death or severe injury.

#### Symbols



..... This symbol ( $\Delta$ ) indicates something that you should be careful of. The picture inside the triangle indicates the nature of the caution that must be taken. (For example, the symbol at left means "beware of injury".)



..... This symbol ( $\ominus$ ) indicates something that you must not do.



..... This symbol ( $\bullet$ ) indicates something that you must do. The picture inside the circle indicates the nature of the thing that must be done. (For example, the symbol at left means "you must make the ground connection".)

## 2. 安全注意事项

### 危险



打开控制箱盖时，必须先关闭电源开关并将电源插头从插座上拔下，至少等待5分钟后，再打开控制箱盖。触摸带有高电压的区域将会造成人员伤亡。



请勿将手放入皮带开口处，否则手可能会将被卷入皮带中造成重伤。

### 注意

#### 使用环境



应避免在强电气干扰源(如高频焊机)的附近使用缝纫机。强电气干扰源可能会影响缝纫机的正确操作。



缝纫机的最佳工作环境是相对湿度在45%-85%的范围内，干燥或潮湿的环境均会影响缝纫机的正确操作。



电源电压的波动应该在额定电压的±10%以内的环境下使用。电压大幅度的波动会影响缝纫机的正确操作。



使用时应避免暴露于直射的阳光下。直射的阳光会影响缝纫机的正确操作。



电源容量应大于缝纫机的消耗能量。电源容量不足会影响缝纫机的正确操作。



万一发生雷电暴风雨时，关闭电源开关，并将电源插头从插座上拔下。雷电可能会影响缝纫机的正确操作。



环境温度应在5°C-35°C的范围内使用。低温或高温会影响缝纫机的正确操作。

#### 安装



请让受过培训的技术人员来安装缝纫机。



固定电缆时，不要过度弯曲电缆或用卡钉固定得过紧，会引起火灾或触电的危险。



请委托购买商店或电气专业人员进行电气配线。



如果使用带小脚轮的工作台，则应该固定小脚轮，使其不能移动。



缝纫机重约40公斤，安装工作必须由两人以上来完成。



缝纫机头倒下或竖起时，请用双手进行操作。单手操作时因缝纫机的重量万一滑落易导致受伤。



在安装完成前，请不要连接电源，如果误接启动开关，缝纫机动作会导致受伤。



使用润滑油或黄油时，务必戴好保护眼镜和保护手套等，以防润滑油落入眼中或沾在皮肤上，这是引起发炎的原因。另外，润滑油或黄油不能饮用，否则会引起呕吐和腹泻。将油放在小孩拿不到的地方。



请在切断电源后，再拔掉电源插头。不然易成为控制箱发生故障的原因。



必须接地。接驳地线不牢固，是造成触电或误动作的原因。

## 2. Notes on safety

### **DANGER**



Wait at least 5 minutes after turning off the power switch and disconnecting the power cord from the wall outlet before opening the face plate of the control box. Touching areas where high voltages are present can result in severe injury.



Please do not put hand in belt openings, or hand may be involved into the belt will be seriously injured.

### **CAUTION**

#### Environmental requirements



Use the sewing machine in an area which is free from sources of strong electrical noise such as high-frequency welders. Sources of strong electrical noise may cause problems with correct operation.



The ambient temperature should be within the range of 5°C to 35°C during use. Temperatures which are lower or higher than this may cause problems with correct operation.



Any fluctuations in the power supply voltages should be within  $\pm 10\%$  of the rated voltage for the machine. Voltage fluctuations which are greater than this may cause problems with correct operation.



The relative humidity should be within the range of 45% to 85% during use, and no dew formation should occur in any devices. Excessively dry or humid environments and dew formation may cause problems with correct operation.



The power supply capacity should be greater than the requirements for the sewing machine's electrical consumption. Insufficient power supply capacity may cause problems with correct operation.



Avoid exposure to direct sunlight during use. Exposure to direct sunlight may cause problems with correct operation.



In the event of an electrical storm, turn off the power and disconnect the power cord from the wall outlet. Lightning may cause problems with correct operation.

#### Installation



Machine installation should only be carried out by a qualified technician.



Hold the machine head with both hands when tilting it back or returning it to its original position. Furthermore, after tilting back the machine head, do not push the face plate side or the pulley side from above, as this could cause the machine head to topple over, which may result in personal injury or damage to the machine.



Contact your dealer or a qualified electrician for any electrical work that may need to be done.



The sewing machine weighs approximately 40kg. The installation should be carried out by two or more people.



All cords should be secured at least 25mm away from any moving parts. Furthermore, do not excessively bend the cords or secure them too firmly with staples, otherwise there is the danger that fire or electric shocks could occur.



Don't connect the power cord until installation is complete, otherwise the machine may operate if the foot switch is depressed by mistake, which could result in injury.



If using a work table which has casters, the casters should be secured in such a way so that they cannot move.



Be sure to connect the ground. If the ground connection is not secure, you run a high risk of receiving a serious electric shock, and problems with correct operation may also occur.



Be sure to wear protective goggles and gloves when handling the lubricating oil and grease, so that they don't get into your eyes or onto your skin, otherwise inflammation can result. Furthermore, do not drink the oil or eat the grease under any circumstances, as they can cause vomiting and diarrhoea. Keep the oil out of the reach children.



Install the safety covers to the machine head and motor.

## 2. 安全注意事项

### 注意

#### 缝纫

 本缝纫机仅限于接受过安全操作培训的人员使用。



为了安全起见，在使用本缝纫机之前，请安装保护装置。如果未安装这些安全装置就使用缝纫机，会造成人身伤害及缝纫机损坏。

 本缝纫机不能用于除缝纫以外的任何其他用途。



缝纫过程中不要触摸任何活动部件或将物件靠在运动部件上，因为这会导致受伤或缝纫机损坏。

 发生下列情况时，请切断电源。否则误按启动开关，缝纫机动作会导致受伤。

- 机针穿线时
- 更换机针或梭芯时
- 缝纫机不使用，或人离开缝纫机时



如果缝纫机操作中发生误动作，或者听到异常的噪声或闻到异常的气味，应立即切断电源。然后与购买商店或受过培训的技术人员联系。

 如果使用带小脚轮的工作台，则应该固定小脚轮，使其不能移动。



如果缝纫机出现故障时，请与购买商店或受过培训的技术人员联系。

#### 清洁



在开始清洁作业前，请切断电源。如果误踩了脚开关，缝纫机动作会导致人员受伤。



使用润滑油或黄油时，务必戴好保护眼镜和保护手套等，以防润滑油落入眼中或沾在皮肤上，这是引起发炎的原因，另外，润滑油或黄油不能饮用，否则会引起呕吐和腹泻。  
将油放在小孩拿不到的地方。

## 2. Notes on safety

### CAUTION

#### Sewing



This sewing machine should only be used by operators who have received the necessary training in safe use beforehand.



If using a work table which has casters, the casters should be secured in such a way so that they cannot move.



The sewing machine should not be used for any applications other than sewing.



Attach all safety devices before using the sewing machine. If the machine is used without these devices attached, injury may result.



Be sure to wear protective goggles when using the machine.  
If goggles are not worn, there is the danger that if a needle breaks, parts of the broken needle may enter your eyes and injury may result.



Do not touch any of the moving parts or press any objects against the machine while sewing as this may result in personal injury or damage to the machine.



Turn off the power switch at the following times, otherwise the machine may operate if the foot switch is depressed by mistake, which could result in injury.

- When threading the needle
- When replacing the needle and bobbin
- When not using the machine and when leaving the machine unattended



If an error occurs in machine operation, or if abnormal noises or smells are noticed, immediately turn off the power switch. Then contact your nearest dealer or a qualified technician.



If the machine develops a problem, contact your nearest dealer or a qualified technician.

#### Cleaning



Turn off the power switch before carrying out cleaning, otherwise the machine may operate if the foot switch is depressed by mistake, which could result in injury.



Be sure to wear protective goggles and gloves when handling the lubricating oil and grease, so that they do not get into your eyes or onto your skin, otherwise inflammation can result. Furthermore, do not drink the oil or eat the grease under any circumstances, as they can cause vomiting and diarrhoea. Keep the oil out of the reach of children.



# 目录 CONTENTS

---

1. 缝纫机的安装 Installation	1
2. 加油 Lubrication	2
3. 油量的调节 Adjusting the amount of oil in the hook	2
4. 机针的安装方法 Attaching The Needle	4
5. 梭芯的安装方法 Setting The Bobbin Into The Bobbin Case	4
6. 上线穿线方法 Threading The Machine Head	4
7. 缝迹长度的调节 Adjusting The Stitch Length	5
8. 线架的安装 Installing The Thread Stand	5
9. 膝动提升高度的调整 Adjusting The Height Of The Knee Lifter	5
10. 踏板操作 Pedal Operation	6
11. 线张力的调整 Adjusting The Needle Thread Tension	6
12. 挑线弹簧 Thread Take-up Spring	7
13. 压脚提升 Hand Lifter	7
14. 压脚压力的调节 Presser Foot Pressure	8
15. 送布相位的调节 Adjusting The Feed Timing	8
16. 送布牙的倾斜 Tilt Of Needle Dog	9
17. 送布牙的高度 Height Of The Feed Dog	9
18. 机针与旋梭的关系 Needle-to-hook Relationship	10
19. 压脚高度的调节 Adjusting The Height Of The Presser Foot	10
20. 定刀与移动刀的转换 Change of fixed knife and shift knife	11
21. 挑线杆挑线量的调节 Adjusting The Thread Take-up	11
22. 踏板压力和行程 Pedal Pressure And Pedal Stroke	12
23. 踏板的调整 Adjusting Of The Pedal	12
24. 手触动倒缝 One-touch Type Reverse Feed Stitching Mechanism	13
25. 脚踏板的连接 Foot switch connection	13
26. 规格 Specifications	14
27. 常见故障与调整 Trouble Shooting Guide	15

---

## 1. 缝纫机的安装 Installation

### (1). 油盘的安装 Installing the oil pan

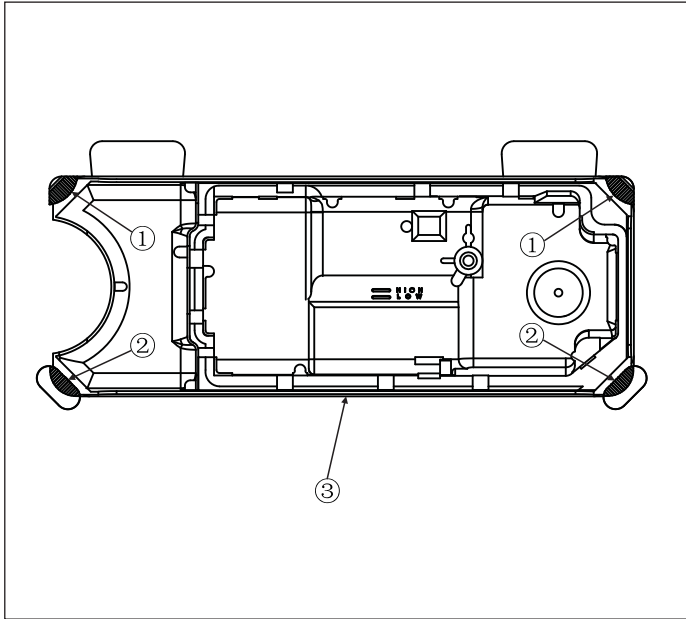

- 1) 油盘应搁在工作台凹槽四角。
- 2) 如图所示,先将两只油盘支座小①与两只油盘支座大②分别置于油盘的四角,然后将油盘③与油盘支座按如图所示方向放置于台板上。

**EN**

- 1) The oil pan should rest on the four corners of the machine table groove.
- 2) Fix two rubber seats ① and two rubber seats ② on the four corners of the oil pan. The oil pan should rest on the machine table groove.

### (2). 铰链的安装 Installing the hinge

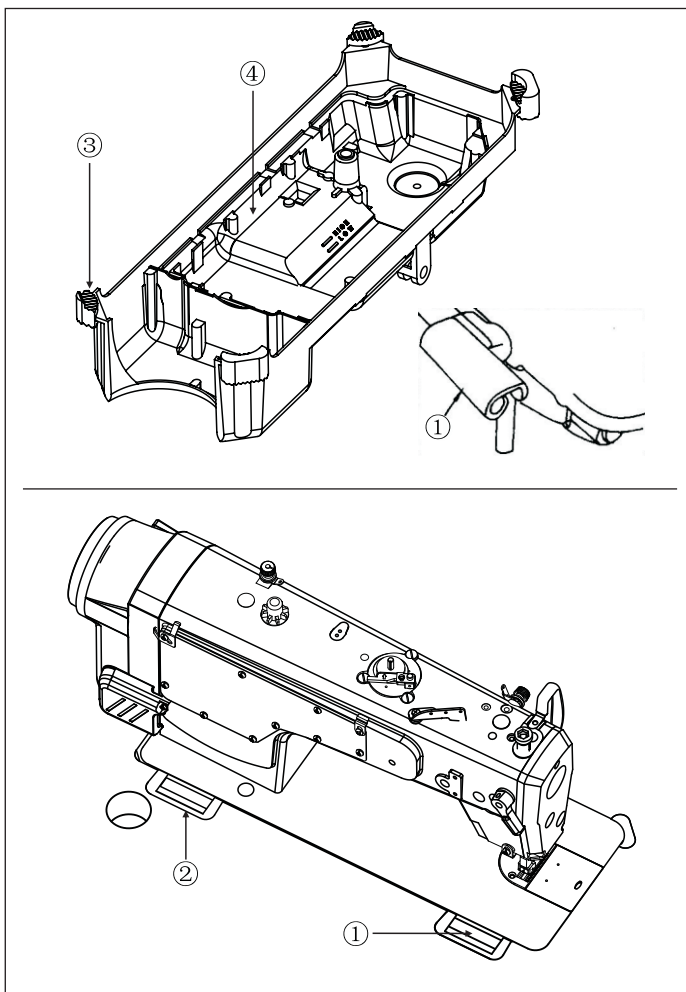

将机头连接钩①放入底板孔内,与台板的机头连接钩座②相嵌合,再将机头放到四只角的机头支座③上。

**EN**

Fit hinge ① into the opening in the machine bed, and fit the machine head to table rubber hinge ② before placing the machine head on cushions ③ on the four corners.

## 2. 加油 Lubrication

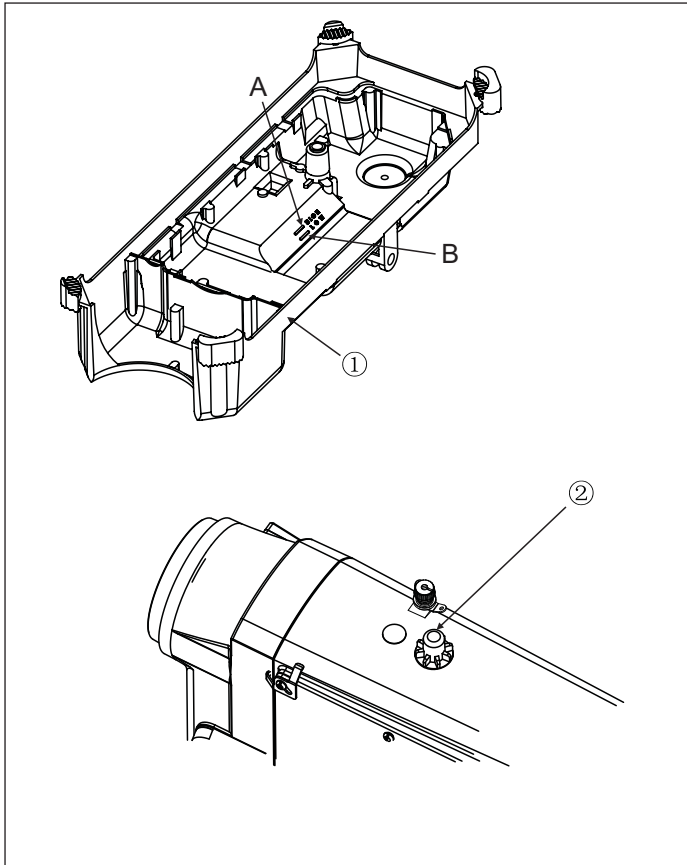

- 1) 把专用10#缝纫机润滑油加入到油盘①，加到HIGH标记A的位置。
  - 2) 如果油面降到LOW标记B以下时，请再次把油加至HIGH位置。
  - 3) 加油后运转缝纫机，润滑正常时应能看到油窗②里油面跳转。
  - 4) 油跳动量的大小与油量的多少无关，因此不用担心。
- (注意)新缝纫机或较长时间没有使用的缝纫机，应进行约10分钟每分3000针的磨合运转。

### EN

- 1) Fill oil pan ① with New Special Oil up to HIGH mark.
  - 2) When the oil level lowers below LOW mark, refill the oil pan with the specified oil.
  - 3) When you operate the machine after lubrication, you will see splashing oil through oil sight window ② if the lubrication is adequate.
  - 4) Note that the amount of the splashing oil is unrelated to the amount of the lubricating oil.
- (Caution) When you first operate your machine after setup or after an extended period of disuse, run your machine at 3000 s.p.m. to 35000 s.p.m. for about 10 minutes for the purpose of break-in.

## 3. 油量的调节 Adjusting the amount of oil

### (1). 旋梭油量调整 Adjusting the amount of oil in the hook

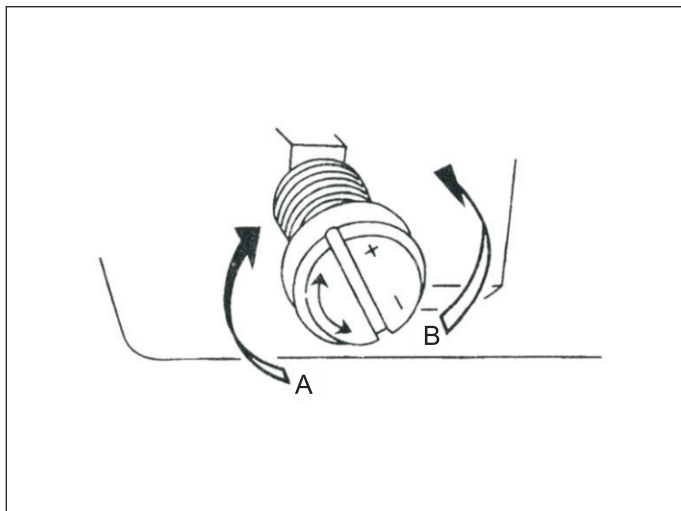

- 1) 把下轴前段部的油量调节螺丝向+方向(A方向)，转动油量增多，向-方向(B方向)转动油量变少。
- 2) 油量调节螺丝调节后，请进行30秒钟的空运转，以确认油量。

### EN

- 1) Turning the oil amount adjustment screw attached on the hook driving shaft front bushing in the + direction (in direction A) will increase the amount of oil in the hook, or in the "-" direction (in direction B) will decrease it.
- 2) After the amount of oil in the hook has been properly adjusted with the oil amount adjustment screw, make the sewing machine run idle for approximately 30 seconds to check the amount of oil (oil splashes) in the hook.

(2). 油量的确认 Confirm the amount of oil

 <b>注意</b> <b>CAUTION</b>	旋梭以调整运转。为了防止人身伤害，请充分注意调节油量。 Be extremely careful about the operation of the machine since the amount of oil has to be checked by turning the hook at a high speed.
--	---

①油量确认专用纸  
①Amount of oil confirmation paper

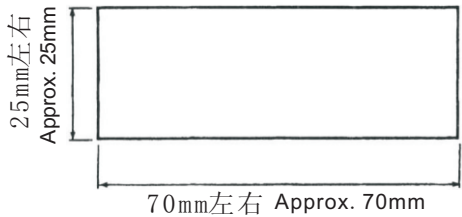

- 不用考虑纸的质量
- Use any paper available regardless of the material

---

②油量确认位置  
②Position to confirm the amount of oil

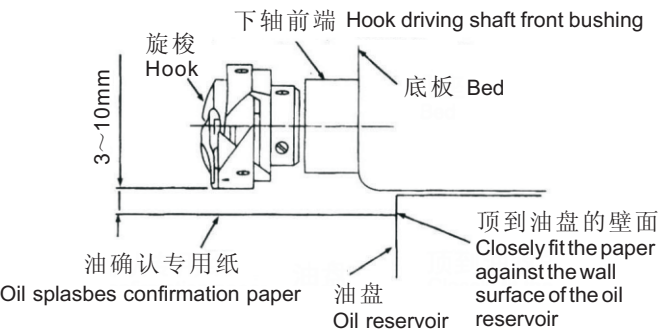

- 把油量确认专用纸插到旋梭下面。
- Place the amount of oil (oil splashes) confirmation paper under the hook.

③适合的油量样品  
③Sample showing the appropriate amount of oil

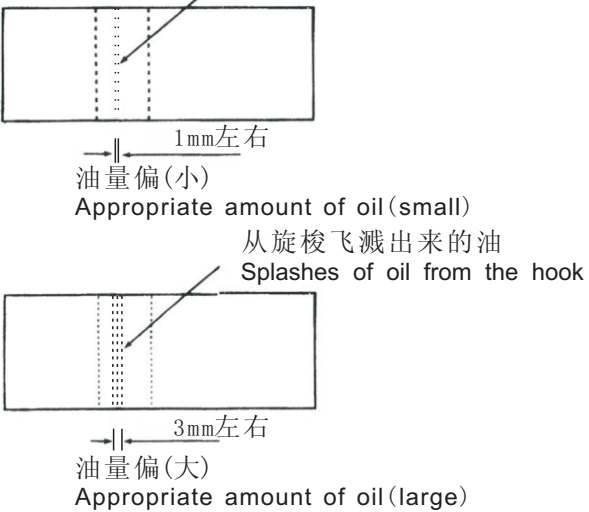

进行下列2的作业时，请卸下推板，同时要充分注意手指不要碰到旋梭。

- 1) 机头冷却时，请进行3分钟左右的空载运转。(适当的间歇运转)
- 2) 请在缝纫机转到时将油量确认专用纸插入。
- 3) 请确认油盘的油面高度是否在HIGH和LOW范围之内。
- 4) 油量确认时间为5秒钟。(用表来测定)

**EN**

When carrying out the procedure described below in 2, remove the slide plate and take extreme caution not to allow your fingers to come in contact with the hook. (Caution)

- 1) If the machine has not been sufficiently warmed up for operation, make the machine run idle for approximately three minutes. (Moderate intermittent operation.)
- 2) Place the amount of oil (oil splashes) confirmation paper under the hook while the sewing machine is in operation.
- 3) Confirm that the height of the oil surface in the oil reservoir is within the range between "HIGH" and "LOW".
- 4) Confirmation of the amount of oil should be completed in five seconds. (Check the period of time with a watch.)

5) 左图样品根据缝制工序需要微调增减，但注意不要过大增加或减少。

(油量过少时，会烧坏旋梭(发热)。油量过多时，会玷污缝制品)

6) 油量应确认3次(3张)均无变化。

**EN**

5) The amount of oil shown in the samples on the left should be finely adjusted in accordance with sewing processes. Be careful not to excessively increase/decrease the amount of oil in the hook. (If the amount of oil is too small, the hook will be seized (be hook will be hot). If the amount of oil is too much, the sewing product may be stained with oil.)

6) Adjust the amount of oil in the hook so that the oil amount should not change while checking the oil amount three times (on the three sheets of paper).

#### 4. 机针的安装方法 Attaching the needle

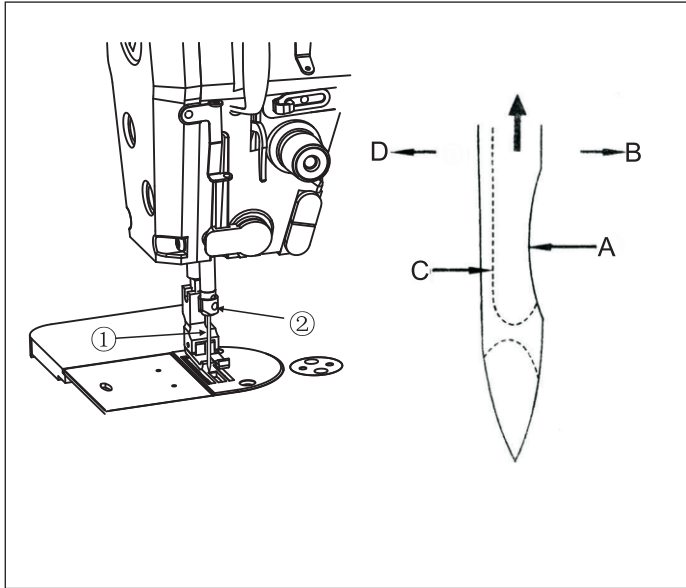

请根据线的粗细、布料的种类选择适当的机针。

- 1) 转动手轮，把针杆升到最高处。
- 2) 拧松机针固定螺丝②，手拿机针把机针①凹部A横向转到B的方向。
- 3) 把机针插到针杆孔的深处。
- 4) 拧紧机针固定螺丝②。
- 5) 确认针的长孔C在左横向D的方向。

**EN**

Select a proper needle size according to the count of thread and the type of material used.

- 1) Turn the handwheel until the needle bar reaches the highest point of its stroke.
- 2) Loosen screw ②, and hold needle ① with its indented part A facing exactly to the right in direction B.
- 3) Insert the needle fully into the hole in the needle bar in the direction of the arrow until the end of hole is reached.
- 4) Securely tighten screw ②.
- 5) Check that long groove C of the needle is facing exactly to the left in direction D.

#### 5. 梭心的安装方法 Setting the bobbin into the bobbin case

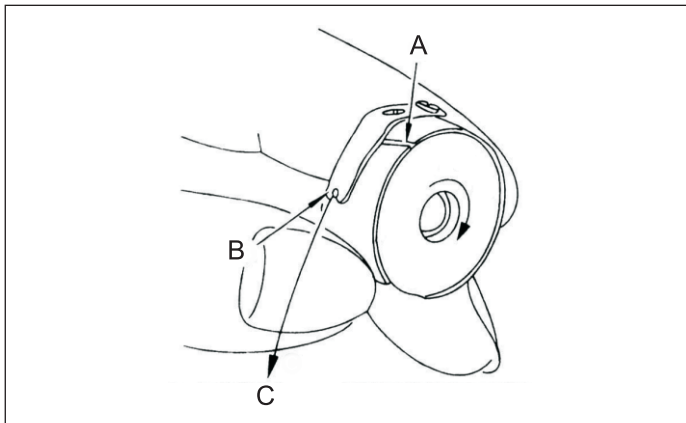

- 1) 手拿梭心，让线往左绕C方向，把它放入梭壳。
- 2) 把线穿过梭壳的穿线口A，然后把线往B方向拉，从线张力弹簧下面的穿线口B拉出来。
- 3) 拉底线C，确认梭心是否按箭头方向转动。

**EN**

- 1) Install the bobbin in the bobbin case so that the thread wound direction is clock wise.
- 2) Pass the thread through thread slit A, and pull the thread in direction B. By so doing, the thread will pass under the tension spring and come out from notch B.
- 3) Check that the bobbin rotates in the direction of the arrow when thread is pulled.

#### 6. 上线穿线方法 Threading the machine head

 <p><b>注意</b> <b>CAUTION</b></p>	<p>为了防止意外的启动造成的事故，请关掉电源后进行。 Turn OFF the power before starting the work so as to prevent accidents caused by abrupt start of the sewing machine.</p>
---	--

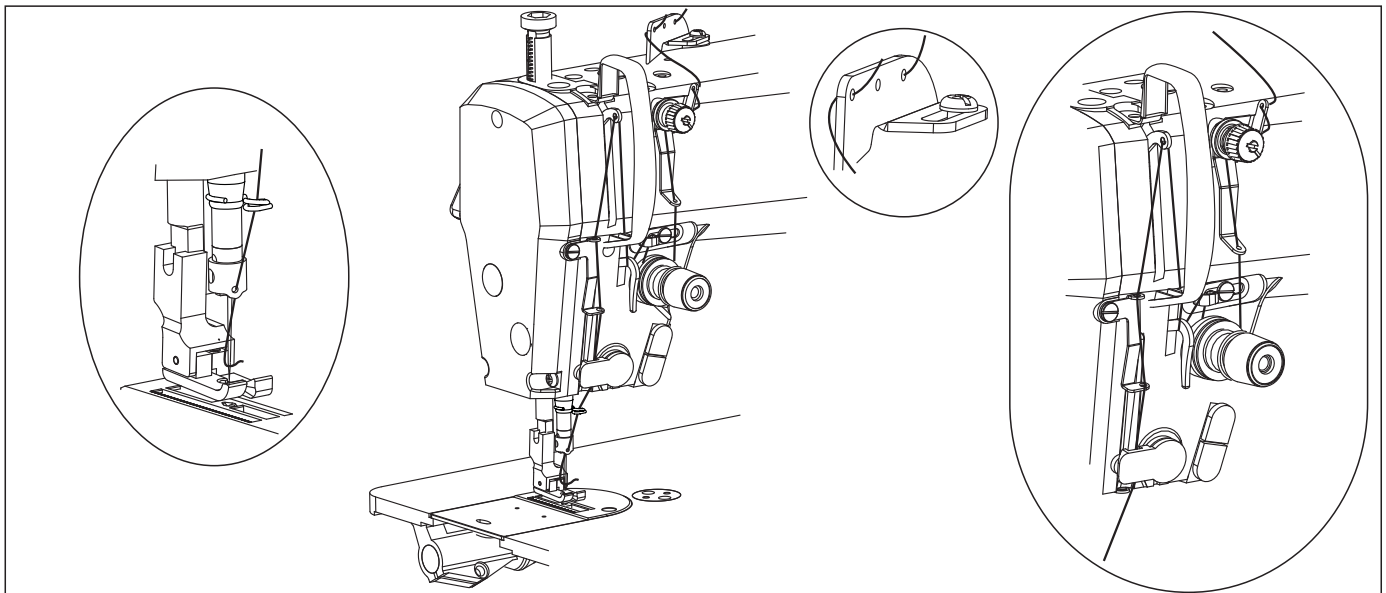

## 7. 缝迹长度的调节 Adjusting the stitch length

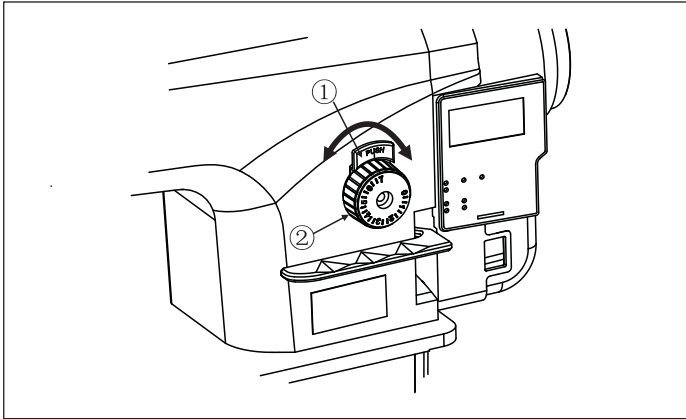

- 1) 按下锁针距压板①沿箭头方向转动送料距旋钮②, 并把希望的数字对准锁针距压板PUSH下面的刻线。
- 2) 刻度盘的数字单位为mm。
- 3) 从大往小变更送布刻度时, 请按下锁针距压板①同时转动送料距旋钮①进行调节。

**EN**

- 1) Press lock stitch plate ① turn stitch length dial button ② in the direction of the arrow, and align the desired number to marker line on lock stitch plate.
- 2) The dial calibration is in millimeters.
- 3) When you want to decrease the stitch length, press lock stitch plate ① while turn stitch length dial button ①.

## 8. 线架的安装 Installing the thread stand

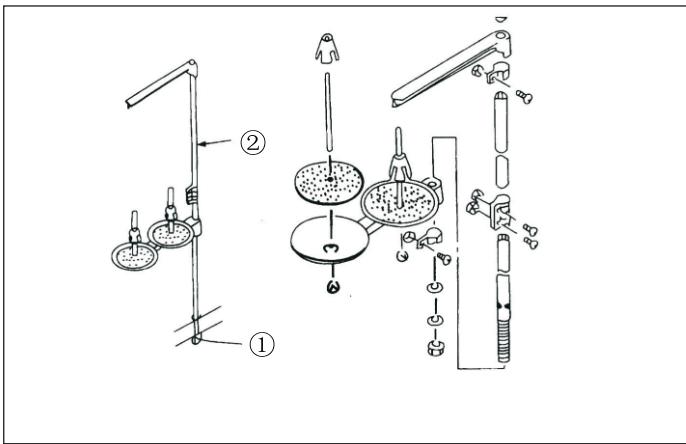

- 1) 如图所示把线架安装到台板右上角孔上。
- 2) 用固定螺母①固定线架。
- 3) 若采用顶线配线时, 请把电源线从线架杆②中穿过。

**EN**

- 1) Assemble the thread stand unit, and insert it in the hole in the machine table.
- 2) Tighten locknut ① to fix the thread stand.
- 3) For ceiling wiring, pass the power cord through spool rest rod ②.

## 9. 膝动提升高度的调整 Adjusting the height of the knee lifter

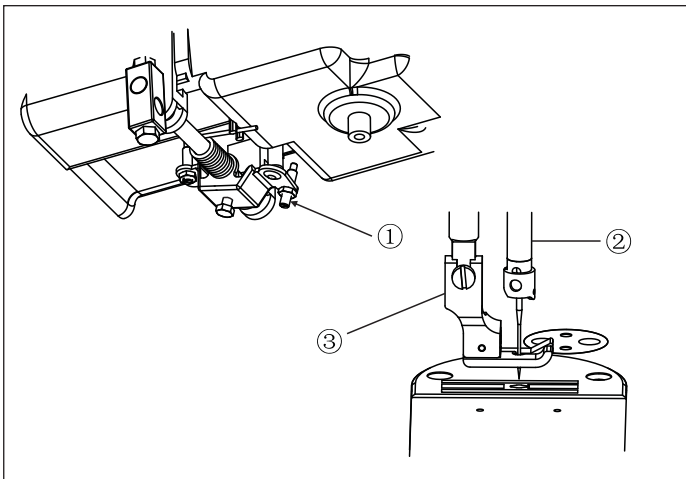

- 1) 膝动提升压脚的标准高度为10mm。
- 2) 调节膝动提升调节螺丝①可以把压脚最高提升到13mm。(薄料机种最大只能调到9mm)
- 3) 压脚提升到10mm以上时, 调整时请注意不要让针杆②的前端在最下方时也不能碰到压脚③。

**EN**

- 1) The standard height of the presser foot lifted using the knee lifter is 10mm.
- 2) You can adjust the presser foot lift up to 13 mm using knee lifter adjust screw ①. (The max, lift should be 9 mm for the weak material)
- 3) When you have adjusted the presser foot lift to over 10 mm, be sure that the bottom end of needle bar ② in its lowest position does not hit presser foot ③.

## 10. 踏板操作 Pedal operation

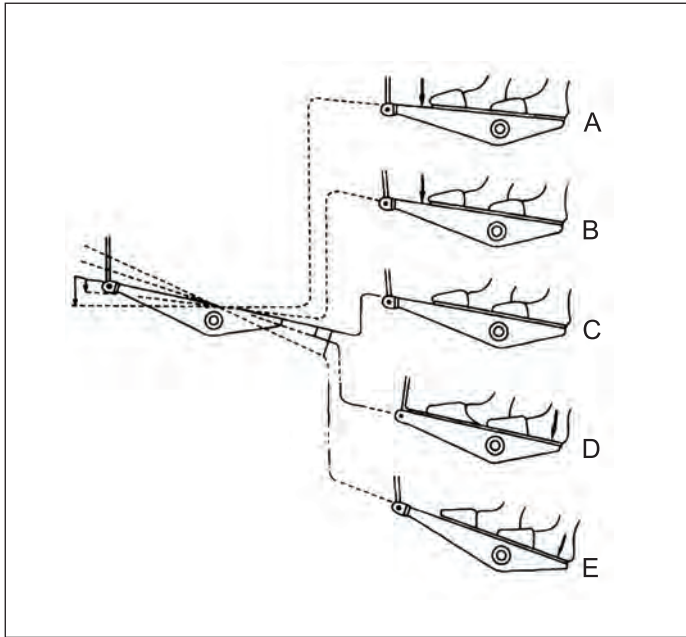

1. 踏板有4级操作。
    - 1) 向前轻轻踩踏板为低速缝纫B。
    - 2) 在继续往前踩踏板为高速缝纫A。（但是，设定了自动倒缝开关后，倒缝结束之后为高速缝纫。）
    - 3) 轻轻踩踏板然后返还缝纫机停止C（机器默认出厂设置为下停针）。
    - 4) 向后踩踏板为切线动作E。
- 若有自动抬压脚功能时，在停止和切线之间增加半后踏抬压脚功能开关。
- 向后轻轻踩踏板，为压脚提升动作D，再继续踩踏板为切线动作。
- 始缝的自动倒缝过程中，把踏板返还中立位置则缝纫机倒缝动作结束后停止。
- 高速缝纫或低速缝纫中向后用力踩踏板缝纫机均可切线。
- 缝纫机切线中把踏板返还中立位置，但机器仍然把线切完。
- 缝纫机停止机针下降之后，如果想升起机针时，请往后踩一次踏板。

EN

1. The pedal is operated in the following four steps.

- 1) The machine runs at low sewing speed when you lightly depress the front part of the pedal .
  - 2) The machine runs at high sewing speed when you further depress the front part of the pedal . (If the automatic reverse feed stitching has been preset, the machine runs at high speed after it completes reverse feed stitching.)
  - 3) The machine stops (with its needle up or down) when you reset the pedal to its original position .
  - 4) The machine trims threads when you fully depress the back part of the pedal .
- If your machine is provided with the Auto-lifter (AK Series). An addition step is given between the machine stop and thread trimming step.

The presser foot goes up when you lightly depress the back part of the pedal, and if you further depress the back part, the thread trimmer is actuated.

- If you reset the pedal to its neutral position during the automatic reverse feed stitching at seam start, the machine stops after it completes the reverse feed stitching.
- The machine will perform normal thread trimming even if you depress the back part of the pedal immediately following high or low speed sewing.
- The machine will completely perform thread trimming even if you reset the pedal to its neutral position immediately after the machine started thread trimming action.
- When the machine stops with its needle down, and if you want to bring the needle up, depress the back part of the pedal once.

## 11. 线张力的调整 Adjusting the needle thread tension

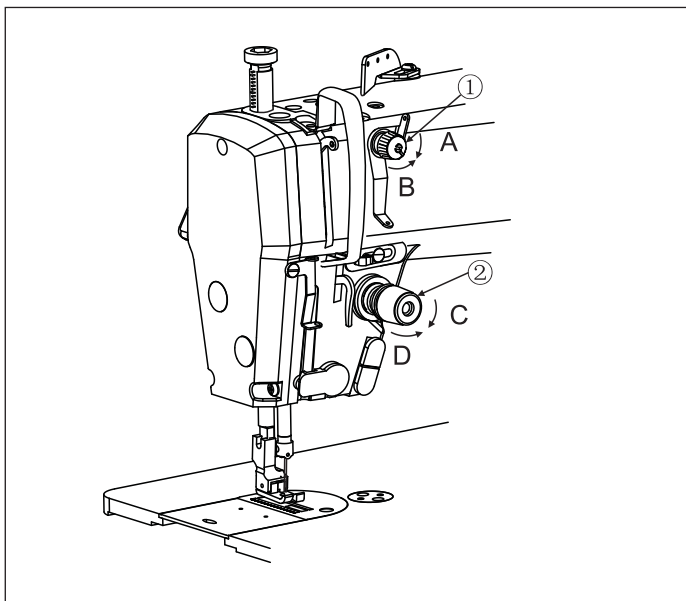

1. 上线张力的调整

- 1) 把第一线张力螺母向顺时针方向（A方向）转动，上线张力变强。
- 2) 把第一线张力螺母向逆时针方向（B方向）转动，上线张力变弱。
- 3) 把线张力螺母2向右C方向逆转，上线张力变强。
- 4) 向左D的方向转动则变弱。

EN

1. Adjusting the needle thread tension

- 1) As you turn thread tension No.1 nut ① clock wise (indirection A), the thread remaining on the needle after thread trimming will be shorter.
- 2) As you turn nut ① counter clock wise (indirection B), the thread length will be longer.
- 3) As you turn thread tension nut ② clock wise (indirection C), the needle thread tension will be increased.
- 4) As you turn nut ② counter clock wise (indirection D), the needle thread tension will be decreased.

## 11. 线张力的调整 Adjusting the needle thread tension

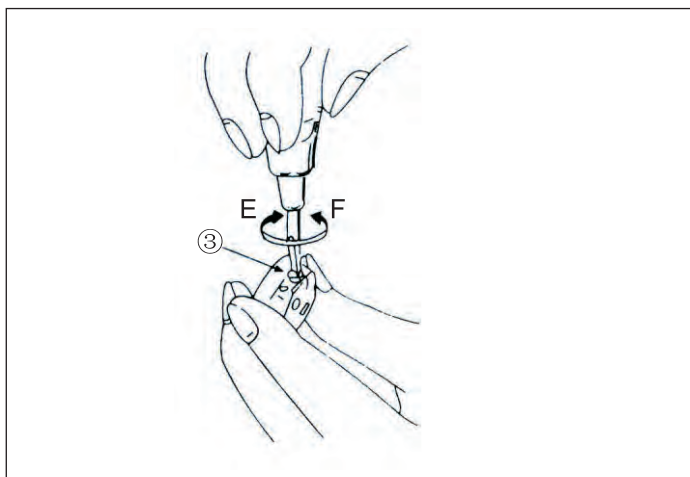

### 2. 底线张力的调整

- 1) 把底线张力螺丝③向右E的方向转动，底线张力变强。
- 2) 向左F的方向转动则变弱。

**EN**

### 2. Adjusting the bobbin thread tension

- 1) As you turn tension adjust screw ③ clock wise (indirection E), the bobbin thread tension will be increased.
- 2) As you turn screw ③ counter clock wise (indirection F), the bobbin thread tension will be decreased.

## 12. 挑线弹簧 Thread take-up spring

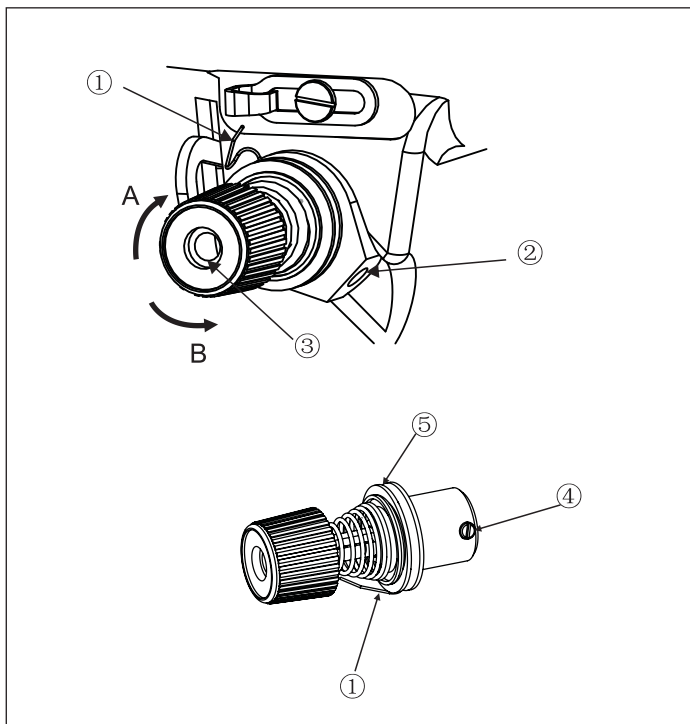

### 1. 要改变挑线弹簧①的行程时

- 1) 拧松固定螺丝②。
- 2) 把夹线螺钉③向右A的方向转动则变大。
- 3) 向左B的方向转动则变小。

### 2. 要改变挑线弹簧1的压力时

- 1) 拧松固定螺丝②，卸下大夹线器组件⑤。
- 2) 拧松夹线螺钉固定螺丝④进行调整。
- 3) 把夹线螺钉③向右A的方向转动则变强。
- 4) 向左B的方向转动则变弱。

**EN**

### 1. Changing the stroke of thread take-up spring ①

- 1) Loosen setscrew ②.
- 2) As you turn tension post ③ clock wise (indirection A), the stroke of the thread take-up spring will be increased.
- 3) As you turn the knob counter clock wise (indirection B), the stroke will be increased.

### 2. Changing the pressure of thread take-up spring ①

- 1) Loosen setscrew ②, and remove thread tension (asm.) ⑤.
- 2) Loosen setscrew ④.
- 3) As you turn tension post ③ clock wise (indirection A), the pressure will be increased.
- 4) As you turn the post counter clock wise (indirection B), the pressure will be decreased.

## 13. 压脚提升 Hand lifter

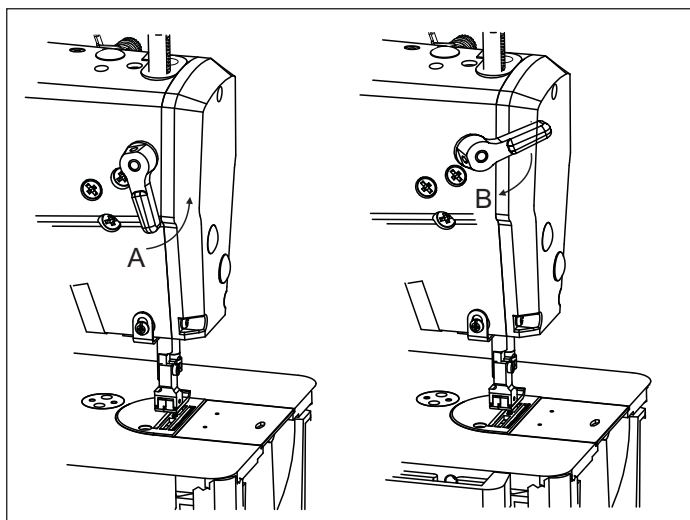

- 1) 让压脚停止到上升的位置，把压脚扳手①提到A的方向。

- 2) 压脚约上升5.5mm(厚料机种为6mm)停止，压脚扳手向B的方向落下压脚则返还原来的位置。

- 3) 膝动提升的标准量为10mm，最大可上升约13mm。

**EN**

- 1) To stop the machine with its presser foot up, turn hand lifter lever ① in the direction A.

- 2) The presser foot will go up about 5.5mm (6mm for thick material) and stop.

The presser foot will go back to its original position when hand lifter lever is turned down in direction B.

- 3) Using the knee lifter, you can get the standard presser foot lift of about 10 mm and the maximum lift of about 13 mm .



## 14. 压脚压力的调节 Presser foot pressure

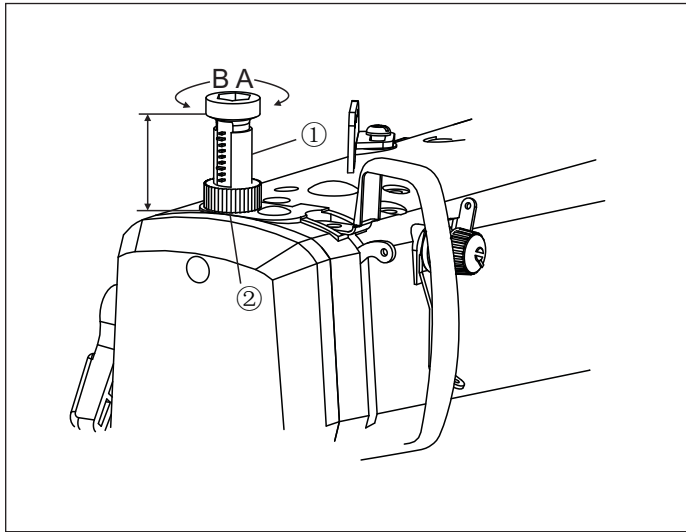

- 1) 拧紧螺母②，把压脚调节螺钉①向右A方向转，力变强。
- 2) 线左B方向转，力变弱。
- 3) 调节后，拧紧螺母②。
- 4) 一般布料时，压脚调节螺钉的标准高度为29~32mm。

**EN**

- 1) Loosen nut ②. As you turn presser spring regulator ① clockwise (in direction A), the presser foot pressure will be increased.
- 2) As you turn the presser spring regulator counter-clockwise (in direction B), the pressure will be decreased.
- 3) After adjustment, tighten nut ②.
- 4) For general fabrics, the standard height of the presser spring regulator is 29 to 32 mm.

## 15. 送布相位的调节 Adjusting the feed timing

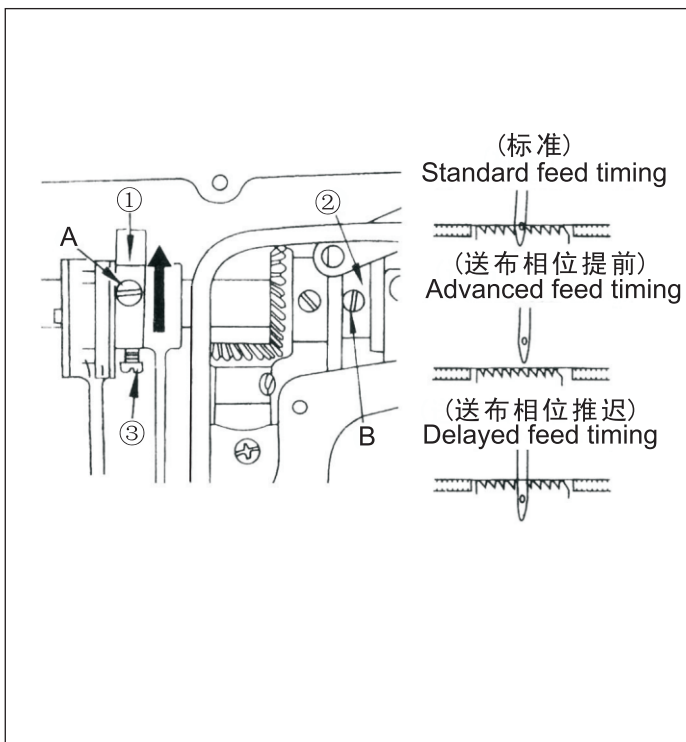

- 1) 拧松送布偏心凸轮①的固定螺丝②、③，朝箭头方向或反箭头方向移动送布偏心凸轮，然后拧紧固定螺丝。
- 2) 标准调节位置是送布牙从针板往下落时，送布牙上面与针孔上端对准针板上面的位置。
- 3) 提早送布相位以防止布偏斜时，请向箭头方向移动送布偏心凸轮。
- 4) 为了良好的紧线而推迟相位时，请逆箭头方向移动偏心凸轮。

**EN**

- 1) Loosen screws ② and ③ in feed eccentric cam ①, move the feed eccentric cam in the direction of the arrow or opposite direction of the arrow, and firmly tighten the screws.
- 2) For the standard adjustment, adjust so that the top surface of feed dog and the top end of needle eyelet are flush with the top surface of throat plate when the feed dog descends below the throat plate.
- 3) To advance the feed timing in order to prevent uneven material feed, move the feed eccentric cam in the direction of the arrow.
- 4) To delay the feed timing in order to increase stitch tightness, move the feed eccentric cam in the opposite direction from the arrow.

### 16. 送布牙的倾斜 Tilt of the feed dog

 <b>注意</b> <b>CAUTION</b>	<p>为了防止意外的启动造成的事故，请关掉电源后进行。          Turn OFF the power before starting the work so as to prevent accidents caused by abrupt start of the sewing machine.</p>
--	---

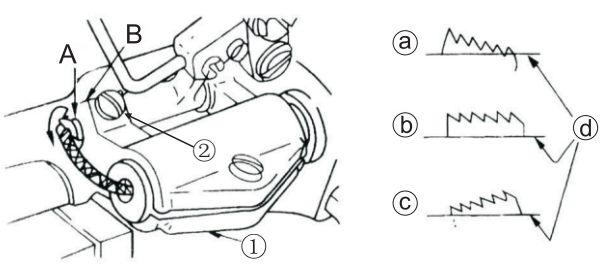

① 前上方 ② 标准 ③ 前下方 ④ 针板  
 a Front up b Standard c Front down d Throat plate

- 1) 标准倾斜(水平)度是送布轴的刻点A和牙架座①的B部下降到20度水平送布轴侧的位置。
- 2) 为了防止缝制皱褶，向前抬起送布牙时，请拧松紧固螺丝②，把螺丝刀插入送布轴，然后沿箭头方向转90度。
- 3) 为了减少布的偏斜，向前下降送布牙时，请沿与前头方向相反方向转90度。

**EN**

- 1) The standard tilt (horizontal of the feel dog is obtained when marker dot A on the feed bar shaft is aligned with marker dot B on feed rocker ①.
- 2) To tilt the feed dog with its front up in order to prevent puckering, loosen the set screw ②, and turn the feed bar shaft 90 degrees in the direction of the arrow, using a screw driver.
- 3) To tilt the feed dog with its from down in order to prevent uneven material feed, turn the feed bar shaft 90 degrees in the opposite direction from the arrow.

### 17. 送布牙的高度 Height of the feed dog

 <b>注意</b> <b>CAUTION</b>	<p>为了防止意外的启动造成的事故，请关掉电源后进行。          Turn OFF the power before starting the work so as to prevent accidents caused by abrupt start of the sewing machine.</p>
--	---

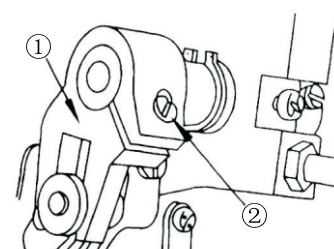

标准 Standard 261-140342 261-140342-A 0.9mm
---

普通型 ⇒ 0.8~1.0mm  
 薄料 ⇒ 0.7~0.9mm  
 厚料 ⇒ 1.0~1.2mm

① Feed dog ② Throat plate  
 a 送布牙 b 针板

- 1) 送布牙①从针板②突出的量请调整为0.8~1.0mm。(厚料时为1.0~1.2mm)。
- 2) 缝制薄料时，送布牙伸出过高时容易起褶。(0.7~0.9mm为适当。)
- 3) 调节送布牙时。
  - 拧松上下拾牙叉形曲柄①的固定螺丝②。
  - 上下移动牙架进行调节。
  - 然后拧紧固定螺丝②。
 (注意) 拧得不紧时，会损伤叉口部。

**EN**

- 1) The feed dog is factory-adjusted so that it jut out from the throat plate surface 0.8 to 1.0 mm (1.0 to 1.2 mm for thick material)
- 2) If the feed dog just out too much puckering may result when sewing tight-weight materials (Recommended protrusion 0.7 to 0.9 mm)
- 3) To adjust the height of the feed dog
  - Loosen screw ② of crank ①.
  - Move the feed barcker up or down to make adjustment.
  - Securely tighten screw ②.
 (Caution) If the clamping pressure is insufficient, the forked portion will wear out.

## 18. 机针与旋梭的关系 Needle-to-hook relationship

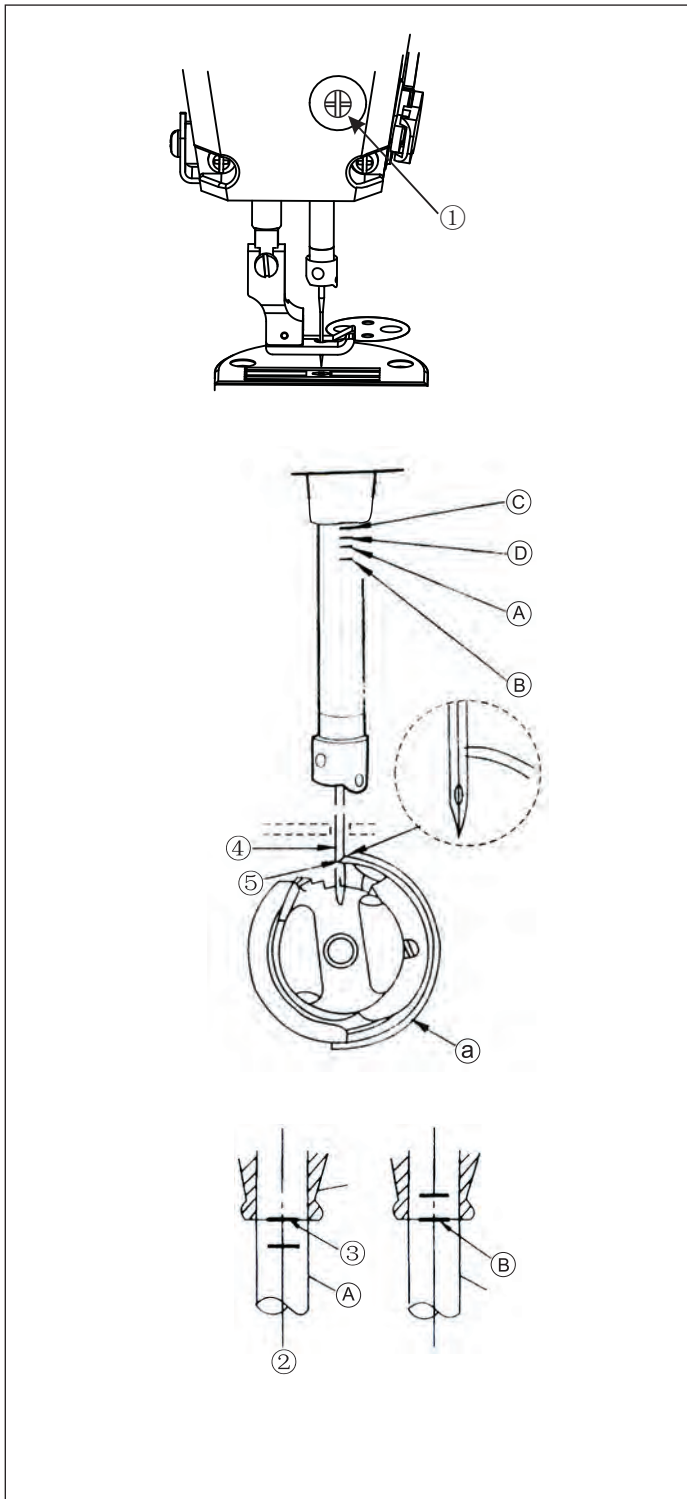

- 1) 转动手轮，让针杆降到最低点，然后拧松针杆连接柱固定螺丝①。  
(决定针杆高度)
- 2) (DB/134规格机针时) 把针杆②的刻线 A 对准针杆下轴套③的下端，然后拧紧针杆连接柱固定螺丝①。  
(DA/88x1规格机针时) 把针杆②的刻线 C 对准针杆下轴套③的下端，然后拧紧针杆连接柱固定螺丝①。  
(决定旋梭a的安装位置)
- 3) (DB/134规格机针时) 拧松旋梭固定螺丝，转动带轮在针杆②上升的方向，把刻线 B 对准针杆下套③的下端。  
(DA/88x1规格机针时) 拧松旋梭固定螺丝，转动带轮在针杆②上升的方向，把刻线 D 对准针杆下套③的下端。
- 4) 在此状态下，让旋梭尖⑤对准机针④的中心，把机针与旋梭的间隙调整为0.04~0.1mm，然后拧紧螺丝。  
(注意) 间隙过小的话，会损伤旋梭尖，间隙过大的话，会跳针。

### EN

1. Adjust the timing between the needle and the hook as follows:
  - 1) Turn the handwheel to bring the needle bar down to the lowest point of its stroke, and loosen set screw ① (Adjusting the needle bar height)
  - 2) (For a DB / 134 needle system) Align marker line A on needle bar ② with the bottom end of needle bar lower bushing ③, then tighten set screw ①.  
(For a DA / 88x1 needle system) Align marker line C on needle bar ② with the bottom end of needle bar lower bushing ③, then tighten set screw ①.  
(Adjusting position of the hook A)
  - 3) (For a DB / 134 needle system ) Loosen the three hook setscrews, turn the handwheel, and align marker line B on ascending needle bar ② with the bottom end of needle bar lower bushing ③.  
(For a DA / 88x1 needle system) Loosen the three hook setscrews, turn the handwheel, and align marker line D on ascending needle bar ② with the bottom end of needle bar lower bushing ③.
  - 4) After making the adjustments mentioned the above steps align hook blade point ⑤ with the center of needle ④. Provide a clearance of 0.04 mm to 0.1 mm (reference value) between the needle and the hook, then securely tighten setscrews in the hook.  
(Caution) If the clearance between the blade point of hook and the needle is smaller than the specified value, the blade point of hook will be damaged. If the clearance is larger, stitch skipping will result.

## 19. 压脚高度的调节 Adjusting the height of the presser foot

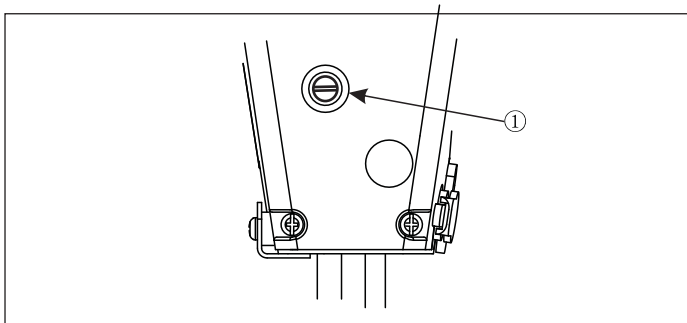

- 1) 变换压脚高度或角度时，请拆下面板孔橡胶塞拧松压脚杆的固定螺丝①进行调节。
- 2) 调节后，再拧紧固定螺丝。

### EN

- 1) Loosen setscrew ①, and adjust the presser foot height and the angle of the presser foot.
- 2) After adjustment, securely tighten the setscrew ①.

## 20. 定刀与移动刀的转换 Change of fixed knife and shift knife

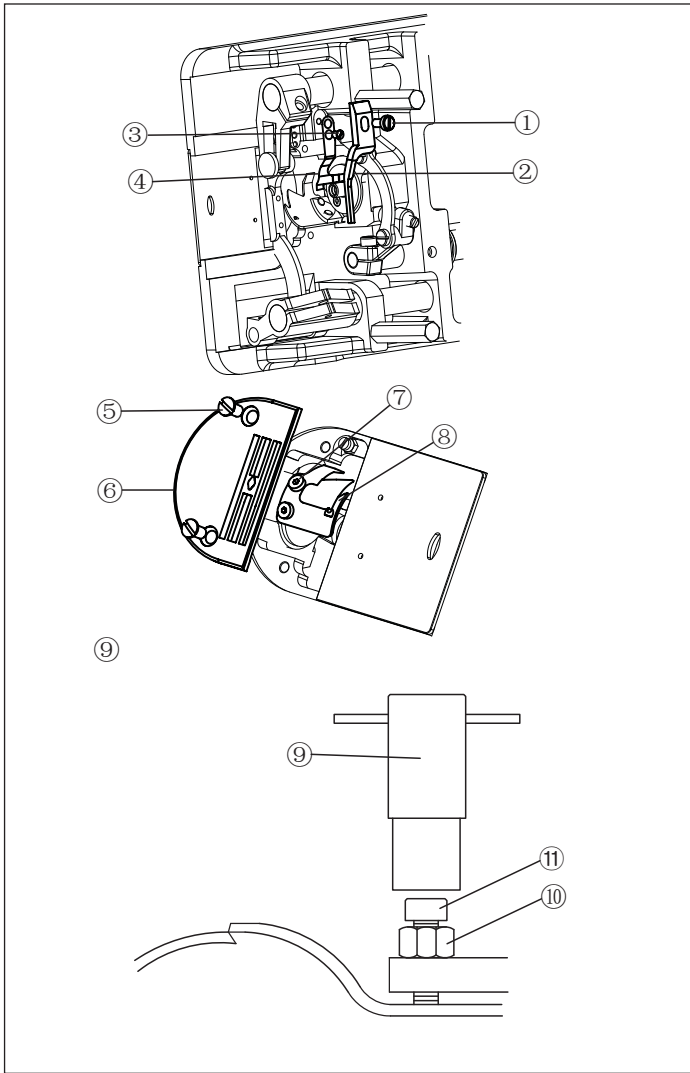

### 定刀的拆卸方法

1. 将缝纫机放倒。
2. 拆下紧固螺钉①和旋梭定位勾②。
3. 拆下沉头螺钉③和定刀④。

### 移动刀的拆卸方法

1. 用压脚扳手将压脚抬起。
2. 拆下沉头螺钉⑤，取下针板⑥。
3. 转动缝纫机主动轮，将针杆停止在最高位置。
4. 拆下沉头螺钉⑦，取下移动刀⑧。

### 定刀压力的调节

1. 拆下沉头螺钉⑤，取下针板⑥；
2. 用套筒扳手⑨松开定刀压力调节螺母⑩，把定刀压力调节螺钉⑪适当往下调。

注1. 拆针板⑥及动刀⑧时，请先取下机针。  
组装按相反的顺序进行。

### EN

#### Removing the fixed knife

1. Tilt back the machine head
2. Remove the screw ① and rotating hook positioner ②
3. Remove the screw ③ and the knife ④

#### Removing the shift knife

1. Let the presser foot up by presser foot lever
2. Remove the screw ⑤ and the needle plate.
3. Turn around the balance wheel, let the needle bar stop highest
4. Remove the screw ⑦ and the knife ⑧

#### Adjusting pressure of the fixed knife

1. Remove the screw ⑤ and the needle plate ⑥.
2. Use the socket spanner ⑨ removing the screw ⑩, moving down the screw ⑪ to appropriate place.

Note: 1. Remove the needle before removing the needle plate ⑥ and the shift knife ⑧.

Installation refer to the reverse order.

## 21. 挑线杆挑线量的调节 Adjusting the thread take-up stroke

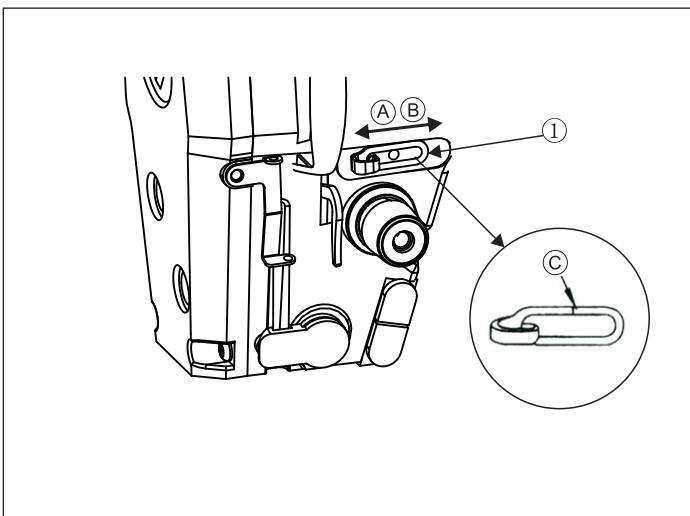

- 1) 缝制厚料时，导线勾①向左 (A) 方向移动，挑线量变大。
- 2) 缝制薄料时，导线勾①向左 (B) 方向移动，挑线量变小。
- 3) 导线勾①的刻线 (C) 在螺丝的中心位置时是标准位置。

### EN

- 1) When sewing heavy-weight materials, move thread guide ① to the left (in direction (A)) to increase the length of thread pulled out by the thread take-up.
- 2) When sewing light-weight materials, move thread guide ① to the left (in direction (B)) to decrease the length of thread pulled out by the thread take-up.
- 3) Normally, thread guide ① is positioned in a way that marker line (C) is aligned with the center of the screw.

## 22. 踏板压力和行程 Pedal pressure and pedal stroke

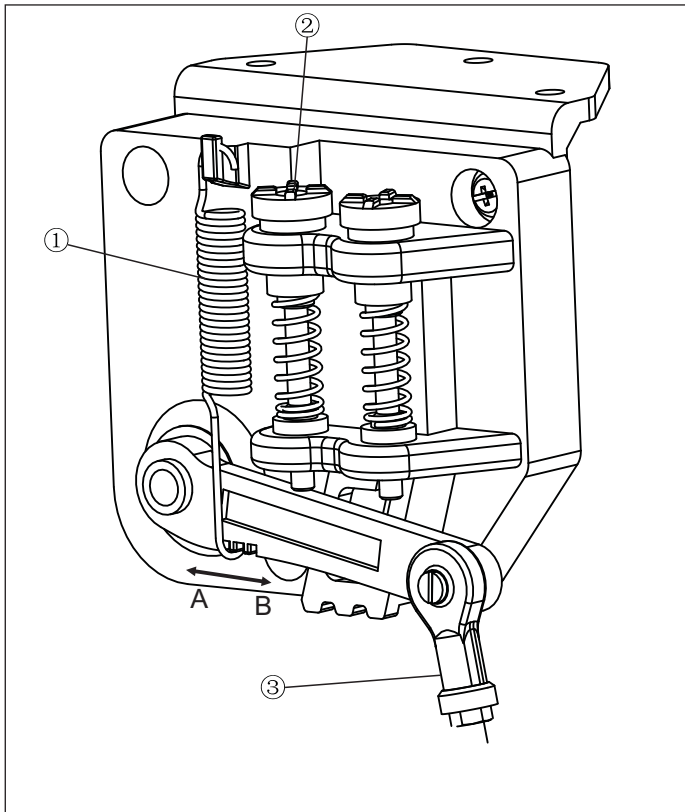

1. 踏板踩踏压力的调整
  - 1) 摘下踏板压力调节弹簧①进行调节。
  - 2) 把弹簧挂到左侧A向压力变轻。
  - 3) 挂到右侧B向压力变大。
2. 踏板返还力的调整
  - 1) 用返踩调节螺丝②可以进行调节。
  - 2) 拧紧调节螺丝压力变大。
  - 3) 拧松螺丝压力变轻。
3. 踏板踩踏行程的调整
  - 1) 把连接杆③安装到左侧的孔内，行程变小。

### EN

1. Adjusting the pressure required to depress the front part of the pedal
  - 1) This pressure can be changed by altering the mounting position of pedaling pressure adjust spring ①
  - 2) The pressure decreases when you hook the spring on the left side.
  - 3) The pressure increases when you hook the spring on the right side.
2. Adjusting the pressure required to depress the back part of the pedal.
  - 1) This pressure can be adjusted using regulator screw ②.
  - 2) The pressure increase as you turn the regulator screw in.
  - 3) The pressure decrease as you turn the screw out.
3. Adjusting the pedal stroke
  - 1) The pedal stroke decreases when you insert connecting rod ③ into the left hole.

## 23. 踏板的调整 Adjustment of the pedal



注意

CAUTION

为了防止意外的启动造成的事故，请关掉电源后进行。

Turn OFF the power before starting the work so as to prevent accidents caused by abrupt start of the sewing machine.

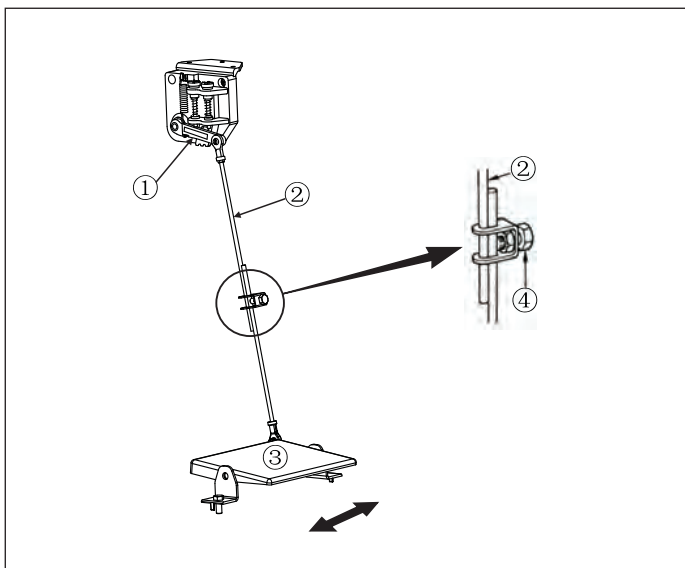

1. 连接杆的安装
  - 1) 向箭头方向移动踏板调节板③，让马达控制杆①和连接杆②成一直线。
2. 踏板的角度
  - 1) 调节连接杆的长度即可以改变踏板的角度。
  - 2) 拧松调节螺丝④，移动连接杆②进行调节。

### EN

1. Installing the connecting rod
  - 1) Move pedal ③ to the right or left as illustrated by the arrows so that motor control lever ① and connecting rod ② are straightened.
2. Adjusting the pedal angle
  - 1) The pedal tilt can be freely adjusted by changing the length of the connecting rod.
  - 2) Loosen adjust screw ④, and adjust the length of connecting rod ②.

## 24. 手触动倒缝 One-touch type recerse feed stitching mechanism

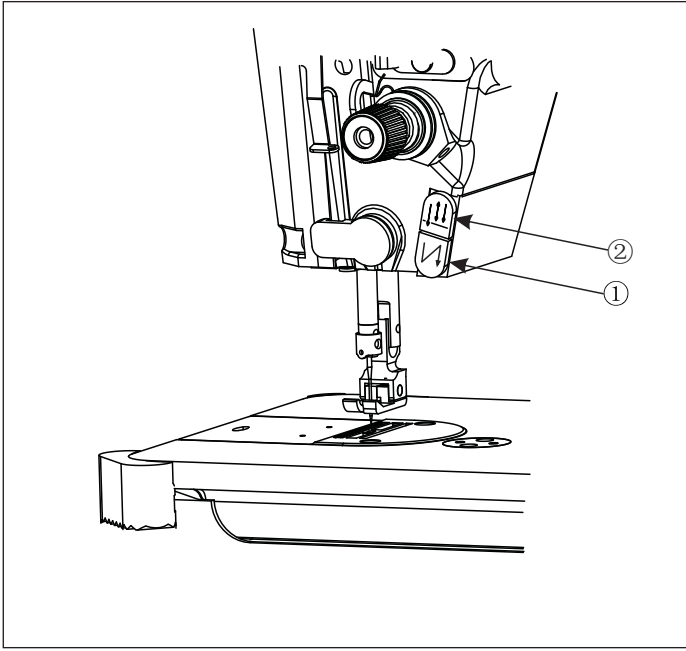

### 1. 倒缝按钮

- 1) 按下倒缝开关①，缝纫机立即倒缝。
- 2) 在按下的时间进行倒缝。
- 3) 手一松开立即变为正向缝纫。

### 2. 补针按钮

- 1) 在缝纫过程中，没有进行剪线动作时，按下补针按钮②然后释放，机器进行一针的补偿。
- 2) 若按下按钮②不放，则直接进行普通缝纫，松开后立即停止。

**EN**

### 1. How to operate

- 1) The moment switch lever ① is pressed, the machine performs reverse feed stitching.
- 2) The machine performs reverse feed stitching as long as the switch lever is held depressed.
- 3) The machine resumes normal feed stitching the moment the switch lever is released.

### 2.Fill needle button:

- 1)In sewing, if the machine can't trim, press the button ② and then release, the machine will fill one needle back.
- 2)Press the button ② all along, the machine sewing as normal, release the button, the foot switch closed.

## 25. 脚踏板的连接 Foot switch connection

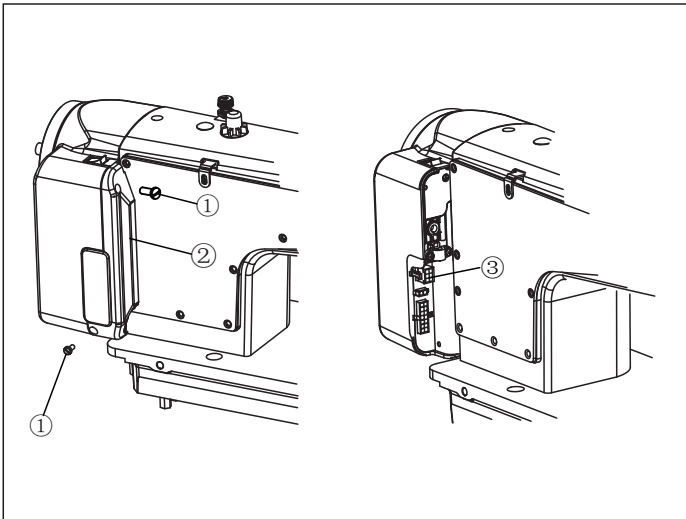

### 脚踏开关的连接

- 1) 当机器及脚踏开关已经安装到台板上以后，卸下两个后电线盖螺钉①，然后卸下后电线盖②；
- 2) 把已经安装好的脚踏板插头插到电控的连接口③的位置，然后轻踩脚踏确认机器能正常运转
- 3) 重新装上后电线盖②，拧紧螺钉①。

**EN**

### Foot switch connection

- 1.When the machine and pedal switch is already installed on the table, discharge these two back wire head bolts①, and then discharge back wire cover②;
- 2.Put the pedal plug into the connector ③of electrical control, then test the machine with treading.
- 3.Re-install the ware head ②, and screw the bolts ①.

## 26. 规格 Specifications

**Noise emission**

Workspace-specific emission value as per DIN EN IOS 10821:

Lc:78 dB(A) at

- stitch length:4mm
- number of stitches:4400 rpm
- sewing material:2-layer material

用途 Application	Single-needle Double Lockstitch Machine With Lower Transport For Light To Moderately Heavy Material
驱动类型 Sewing drive	直接驱动 Direct-drive

规格型号 MODLE	261-140342	261-160362	261-140342-A	
最高缝纫速度 Max.sewing speed	5000	3500	5000	
最大针迹长度 Max.Stitch Lengh	5mm	7mm	5mm	
压脚提升高度 ( mm ) Presser Foot Lift	手提 Hand lift	5.5mm	6mm	5.5mm
	膝提 Knee lift	12mm ( 最大 ) 12mm ( Max )		
	自动抬压脚 Auto lift	9mm		
机针 Needle	Nm80	Nm110	DBX1 #14	
电机功率 ( W ) Motor Power	550W			
润滑油 Lubricating Oil	Lubricating Oil DA 10: Viscosity at 40 °C: 10 mm <sup>2</sup> /s Flash point: 150 °C			

## 27. 常见故障与调整

在修理、服务之前请先按下面要点检查；  
按照下方法处理仍不能排除故障时，请关掉电源开关，并及时与缝纫机经销商联系。

故障现象	产生原因	调整方法	页码
断线	①穿线是否正确	正确地穿线	4
	②上线张力过强或过弱	把张力调到适当	6
	③机针是否安装正确	正确安装机针	4
	④针尖是否弯曲、钝	更换机针	
	⑤旋梭、梭壳、挑线杆等过线道上无伤痕	修正伤痕或更换新品	
	⑥旋梭内是否有线头	清理旋梭	
	⑦线有问题		
	• 线的质量不好	换成质量好的线	
	• 线太粗	使用适当的针或适当的线	
	• 线受热溶解	安装线冷却装置	
	⑧机针型号调换	重新调整机针和旋梭的配合位置	
⑨跳针	参照下一项目跳针。		
跳针	①机针的安装方法不正确		
	• 没有完全插入针杆	把针插到针杆的顶部	
	• 针孔没有对正	把针孔安装到正面	
	• 针装反了	把长槽转到前面	
	②针尖是否弯曲或损坏	更换机针	
	③穿线是否正确	正确地穿线	4
	④旋梭尖弯曲或折断	修理旋梭尖或更换新品	
⑤机针和旋梭的同步不好	调整同步	10	
⑥机针与旋梭的间隙过大	调整间隙	10	
线迹不均匀	①压脚压力是否太小或太大	调节压脚压力	8
	②送布牙是否太低	调节送布牙齿的高度	9
	③梭心是否损坏	磨擦毛刺或更换梭心	
	④V形皮带是否太松	调整到用手指推皮带时压下5-10mm	
线迹起皱	①上线与底线张力过强	逐渐调弱上线与底线的张力	7
	②压脚压力过强、送布牙过高	调整压脚压力、调低送布牙位置	7~9
	③机针尖损坏	更换机针	4
	④机针太粗	尽可能使用小号机针	
	⑤送料相位调整是否准确	参照“送料相位的调节”	8
开始缝纫时 上线脱线	①开始缝纫时，挑线杆未在最高位置	缝制开始时，挑线杆调到最高位置	
	②上线穿过机针余量太少	线从机针的线孔穿出50mm左右	
	③小夹线器压力太大	调整小夹线器压力	
	④上针停止位置过高线被挑线拉出	调整上停针位置	
始缝时跳线	①切线时，梭心空转	更换梭心	4
	②梭心里的底线长度短，不出底线	更换梭心	4
	③切线后针孔的上线余量过短	调节小夹线器	



## 29. 常见故障与调整

故障现象	产生原因	调整方法	页码
断针	①机针是否外物碰撞弯曲了	更换机针	
	②机针的质量不好	更换质量好的机针	
	③机针没有完全插入针杆	插到针杆的顶部	
	④机针与旋梭相碰	调整针和旋梭的同步和间隙	10
	⑤与缝料和线相比针太细	换合适的机针	
	⑥机针与针板相碰	调正机针与针板的位置	
	⑦机针与压脚相碰	调正机针与压脚的位置	
上下线切不断	①定刀与动刀磨损、不锋利	更换定刀、动刀	11
上线切不断	①机针安装方法不对	正确安装机针	4
	②夹线簧的行程太大	减小夹线簧行程	
	③梭子定时配合不良	以低速启动, 检查跳针现象, 校正梭子的时间配合	
底线切不断	①动刀后退量调节不良	检查动刀的后退量, 调整剪线凸轮的左右位置, 以使切刀后退量达到适当的范围	11
	②剪线时底线位置不固定	检查梭子上有无底线引槽, 若没有引槽, 应调换梭子	
正向送布与反向送布针迹不一致	①送布牙斜度调整不良	调整送布牙斜度	9
面线不佳, 底线好 (浮线)	①面线线迹总体不好		
	• 梭皮或梭壳被线磨出线槽, 拧紧后线还松的	更换新梭皮或将梭壳的线槽磨平	
	• 送布时间与挑线时间配合过慢	打开机头侧盖板, 松开主轴上的偏心轮紧固螺钉, 将偏心轮固定不动, 手转动皮带轮向机器运动的反方向转动一点, 旋紧偏心螺钉. 试车, 一次调一点点直到面线好为止	
	• 梭壳与旋梭花栏配合不佳	更换梭壳	
	• 底线过于收紧, 面线无法收回	放松机头夹线器螺丝, 直到底、面线均匀为止	
	②面线出现时好时坏现象		
	• 梭皮无弹力, 压不住线	更换新的	
	• 梭壳与旋梭的出线口配合不佳	更换梭壳	
• 针板孔、定位勾有毛刺	对其进行抛光, 确保线的出入顺畅		
底线不好, 面线好 (浮线)	①面线的张力不够	略为加大夹线器弹簧及挑线簧的弹力	
	②机器机构相互运动配合不良	打开机头侧盖板, 松开主轴上的偏心轮紧固螺钉, 将偏心轮固定不动, 手转动皮带轮向自己座位方向转动一点 (逆时针方向), 旋紧偏心螺钉. 试车, 一次调一点点直到底线好为止	
	③定位勾与旋梭之间的间隙太小或有毛刺	间隙太小可将定位勾装开些、有毛刺可通过抛光处理	
	④旋梭的弧形过或小螺钉有毛刺	通过抛光或磨光处理	
	⑤机针未对准定位勾和旋梭勾线部的中间	调整定位勾使机针对准它们的中间	
	⑥旋梭与花栏之间间隙太小或花栏有毛刺	重新调整它们之间的间隙、对花栏进行抛光	

If you notice any of the problems listed below refer to the "Remedy" column for instructions on how to solve the problem. Our dealer or a qualified technician to carry out the necessary adjustment.

Phenomena	Possible cause	Remedy	Page
Thread breakage	①Is the needle properly installed	Re-threading correctly	4
	②When the needle thread is excessively tight or loose	Adjust the thread tension	6
	③Is the needle properly installed	Install the needle correctly	4
	④Is the needle tip bent or blunt	Replace the needle	
	⑤When there is a scratch on the thread catch of the sewing hook、bobbin case, there take-up lever or any other parts	Remove such a scratch or replace the component	
	⑥Is thread in the rotary hook	Clean the rotary hook	
	⑦When the thread is not suitable		
	·The quality of the thread is poor	Select good quality thread	
	·The thread is too thick	Use a suitable needle or thread	
	·The thread is broken by heat	Use silicone oil lubricant unit	
	⑧replace the type of needle	Adjust the position of needle and rotating shuttle over again	
⑨Stitch skipping	Refer to the following paragraphs stitch skipping		
Stitch skipping	①When the needle is inserted in a wrong way		
	·the needle is not entirely into the needle bar	Fully insert the needle	
	·The needle eye is not facing straight to the operator	Let the needle eye face straight to the operator	
	·The thread is facing backwards	Let the long groove on the needle face to the operator	
	②Is the needle tip bent or blunt?	Replace it with a new needle	
	③Is the needle properly installed	Re-threading correctly	4
	④When the hook blade point is not sharp enough or damaged	repair the hook or replace it	
	⑤When the timing of the sewing hook and the needle is not matched	Adjust the timing properly	10
⑥When the clearance between the needle and the sewing hook is too great	Adjust the clearance	10	
Seams don't match	①Is the presser foot pressure too weak or strong	Adjust the presser foot pressure	8
	②Is the feed dog too low ?	Adjust the feed dog height	9
	③Is the bobbin scratched?	If bobbin is damaged .smooth it will an oiled grindstone or replace it	
	④Is the V-belt tension too low	Adjust so that there is 5-10mm of deflection in the V-belt when it is pushed with a finger	
Poor thread tightening	①The upper thread and lower thread tension is too strong	Adjust the thread tension	7
	②The presser foot pressure is too strong	Decrease the presser foot pressure	7~9
	③The needle tip is broken	Replace the needle	4
	④The needle is too thick	Use as thin a needle as possible	
	⑤whether the adjustment of feed position is correct	consult the adjustment of feed position	8

If you notice any of the problems listed below refer to the "Remedy" column for instructions on how to solve the problem. Our dealer or a qualified technician to carry out the necessary adjustment.

Phenomena	Possible cause	Remedy	Page
Upper line comes out of the needle hole at the sewing start	①The thread take-up lever is not at its highest position at the sewing start	Set the thread take-up lever to the highest position at the sewing start	
	②The thread end is too short for the needle hole at the sewing start	Approx50 <sup>mm</sup> of thread should be coming out of the needle hole	
	③The upper thread tension is too strong	Adjust the upper thread tension	
	④ upper looper fixed too high thread being take-up	adjust the position of upper looper	
The thread comes out of the needle hole at the sewing start	①when cut thread, the bobbin is racing	Replace the bobbin	4
	②the length of base line inside bobbin is short and cannot appear base line	Replace the bobbin	4
	③the pinhole upper line is too short after cutting thread	adjust thread tension	
The needle is broken	①When the needle is bent	Replace the needle	
	②The quality of the needle is poor	Select good quality needle	
	③ the needle is not entirely into the needle bar	Fully insert the needle	
	④When the needle hits the sewing hook	Adjust the timing and clearance between the needle and the sewing hook and also the position of the needle guard	10
	⑤The needle is too thin for the thread	Use a suitable needle	
	⑥The needle hits against the throat plate	adjust needle and needle plate position	
	⑦ The needle hits against the presser foot	adjust needle and press foot position	
upper line and base line cannot cut	①fixed knife and move knife are abrasion ,blunt	change fixed knife and move knife	11
upper line cannot cut	①When the needle is inserted in a wrong way	Install the needle correctly	4
	②the distance of thread tension spring is too long	decrease the distance of thread tension spring	
	③hook timing is not good to cooperate	start in low speed and check slip stitch, revise time cooperation of hook	
base line cannot cut	①cutting quantity cannot adjust well	Check the cutting quantity, adjust the left and right position of cutting thread cam, so that it can reach proper scope	11
	②the base line is not fasten when cutting	check whether there is base guide slot, if not, exchange hook	
needle mark is not consistent in observe feed and reverse feed	① the slope of feed dog cannot adjust well	Adjusting the feed dog incline	9

If you notice any of the problems listed below refer to the "Remedy" column for instructions on how to solve the problem. Our dealer or a qualified technician to carry out the necessary adjustment.

Phenomena	Possible cause	Remedy	Page
it is not so good of face line, however the base line is good	①the face line stitch is not good		
	· hook skin and hook case are milled thread slot, the thread still lax after fasten	change new hook skin or rub down hook case thread slot.	
	· the speed is slow when feeding and picking thread	Opening the side cover board of machine top, loosen the eccentric cam in principal axis and fasten bolt, fix up eccentric cam, turn strap wheel a little to opposite position by hand, close eccentric screw, test drive. adjust a bit till it is ok.	
	· hook case and rotating hook cooperate not good	Replace it with a new bobbin case	
	· the base line is too tight that face line cannot back	release thread tension screw, until make sure base and face line equality	7
	② face line appears broke down sometimes but sometimes is ok		
	· there is no elasticity of hook skin, thus cannot press down the thread	use new hook skin instead	
	·hook case and the thread exit of rotating hook cooperate not good	Replace it with a new bobbin case	
base line is not good ,but face line is good	·there is burr in the hole of needle plate, orientation hook	polishing them, and make sure thread go	
	①When the needle thread tension is too low	increase spring of thread tension spring and thread take-up spring	
	②the structure interact cooperation not good	Opening the side cover board of machine top, loosen the eccentric cam in principal axis and fasten bolt, fix up eccentric cam, turn strap wheel a little to opposite position by hand, (counter-clockwise )close eccentric screw, test drive. Adjust a bit till	
	③ positioning finger and rotating hook clearance is too small or there is burr	move positioning finger or polishing to solve it	
	④the arc of rotating or set screw have burr	deal it through polish or burnish	
	⑤ needle is not aim at the middle of poisoning finger and rotating hook	adjust poisoning finger to aim the middle	
	⑥hook case and rotating hook clearance is too small or there is burr	adjust the clearance of them and polishing	

# 零件目录 PARTS CONTENTS

---

1. 机壳部件 .....	1
Frame Components	
2. 上轴及挑线部件 .....	5
Main shaft & thread take-up components	
3. 针杆、竖轴、下轴部件 .....	7
Needle bar, vertical shaft & hook driving shaft components	
4. 抬压脚部件 .....	9
Hand Lifter & Tension Release Components	
5. 送料部件 .....	11
Feed Mechanism Components	
6. 切线装置部件 .....	15
Thread Trimmer Components	
7. 自动倒送料部件 .....	17
Automatic Reverse Feed Components	
8. 润滑部件 .....	19
Oil Lubrication Components	
9. 油盘、膝抬压脚部件 .....	21
Oil Reservoir & Knee Lifter Components	
10. 线架部件 .....	23
Thread Stand Components	
11. 附件 .....	25
Accessories	
12. 厚料大旋梭部件 .....	27
Heavy duty big hook components (261-160362)	
13. 内置抬压脚部件 .....	29
Built-in presser foot Components	

1. 机壳部件 Frame Components

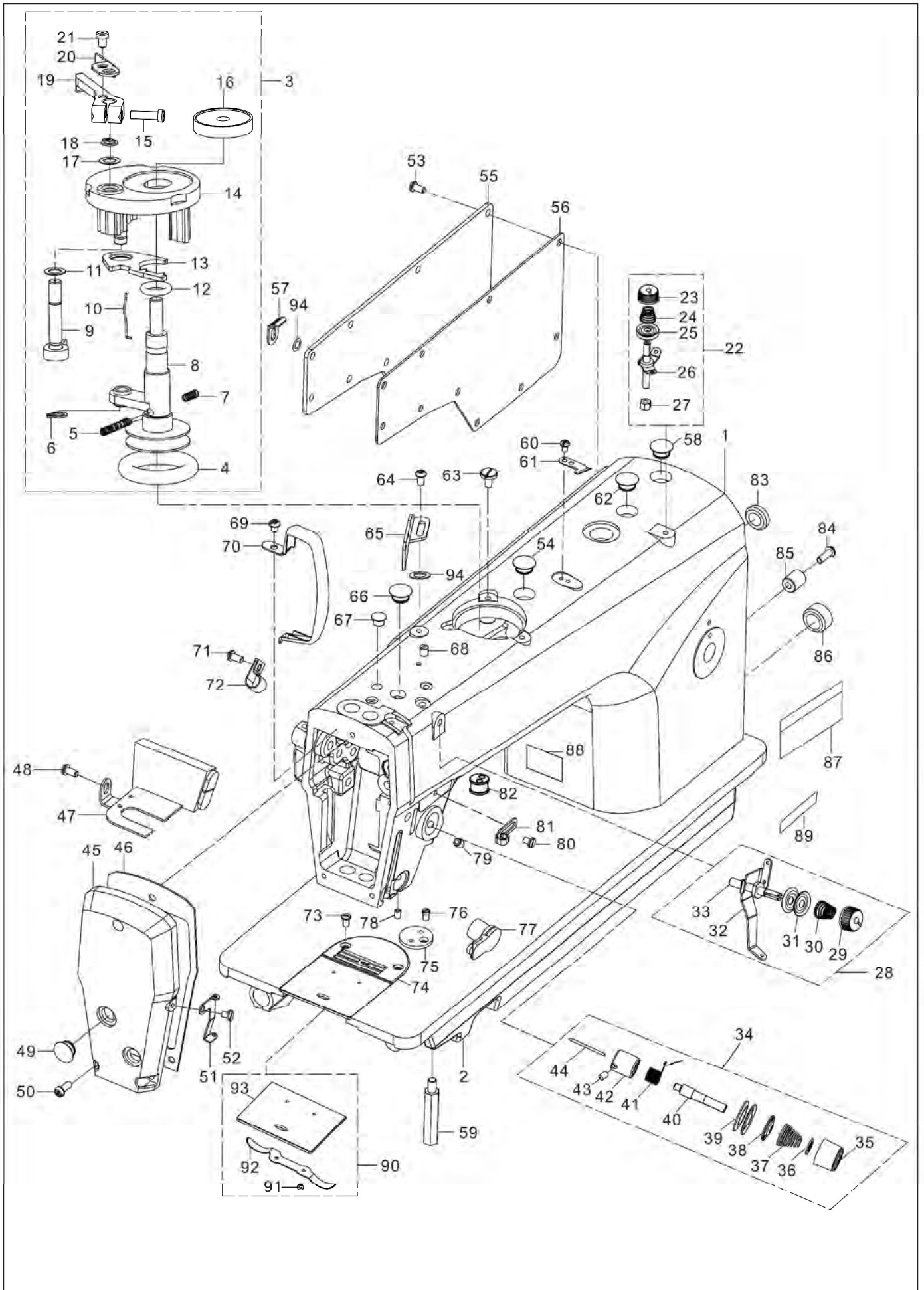

## 1.机壳部件 Frame Components

序号 NO.	图号 REF NO.	名称	DESCRIPTION
1	SG1281-05-01	机壳	Machine Frame
2	SG1230-01-01-02	底板	Bed
3	SG1281-05-07	绕线器组件	Bobbin Winder Asm.
4	SG31-25070000-09	O型圈	O Ring
5	SG134-02-01	压紧弹簧	Presser Foot Spring
6	SG24-05000000-08	固定卡簧	Retaining Ring
7	SG134-02-01-10	弹簧	Spring
8	SG134-02-01-01	绕线轴组件	Bobbin Winder Asm.
9	SG134-02-01-06	绕线凸轮轴组件	Bobbin Winder Cam Asm.
10	SG134-02-01-12	梭心防转弹簧	Latch Spring
11	SG134-02-01-08	绕线器扳手轴调整垫圈	Vertical Roller Washer
12	SG31-09428000-09	O型圈	Rubber Ring
13	SG134-02-01-07	绕线制动传动板	Adjusting Plate
14	SG134-02-01-05	绕线座	Bobbin Fitting Basis Compl
15	SG11-60091320-01	固定螺钉	Screw Sm9/64x40 L=13
16	SG134-02-01-11	梭心垫	Bobbin Cushion
17	SG134-02-01-08	绕线器扳手轴调整垫圈	Vertical Roller Washer
18	SG24-05000000-08	卡簧	E-ring
19	SG134-02-01-02	绕线控制扳手	Bobbin Lever
20	SG134-02-01-04	绕线调节板	Bobbin Winder Adjust Plate
21	SG11-40090625-01	紧定螺钉	Screw Sm9/64x40 L=6
22	SG1281-05-13A	绕线夹线器组件	Bobbin Thread Tension Asm.
23	SG134-02-02-01	夹线螺母	Thread Tension Nut
24	SG134-02-02-04	夹线簧	Connecting Rod Spring
25	SG134-02-02-03	夹线板	Thread Tension Disk
26	SG134-02-02-02	夹线柱组件	Bobbin Thread Tension Rod Asm.
27	SG13-60115520-02	锁紧螺母	Nut Sm11/64x40
28	SG1281-05-14A	小夹线器组件	Pre-tension Asm.
29	SG109-01-26	夹线螺母	Tension Nut
30	SG109-01-25	夹线弹簧	Tension Spring
31	SG109-01-24	夹线板	Thread Guide Disc
32	SG109-01-23	上过线板	Through Thread Plate
33	SG109-01-22	导线柱	Needle Thread Guide Pin
34	SG1281-05-12A	大夹线器组件	Pre-tension Asm.
35	SG101-03-28	夹线螺母	Tension Nut
36	SG101-03-27	夹线制动板	Tension Disc Stopper
37	SG101-03-26	夹线簧	Tension Spring
38	SG101-03-25	松线板	Tension Disc Holder
39	SG101-03-24	夹线板	Thread Guide Disc
40	SG101-03-21	夹线螺钉(柱)	Tension Pole
41	SG101-03-20	挑线簧	Take-up Spring
42	SG101-03-19-01	挑线簧调节座	Tension Pole Socket
43	SG11-80090610-01	夹线座紧固螺钉	Screw Sm9/64x40 L=6
44	SG101-03-23	松线钉	Thread Release Pin
45	SG1281-01-07	面板	Face Plate
46	SG1281-01-08	面板垫	Face Plate Gasket
47	SG1281-05-18A	倒送料转换器组件	Reverse Feed Switch Asm.
48	SG11-40120625-05	倒送料转换器固定螺钉	Screw Sm3/16x28 L=6
49	SG101-01-11	面板调节螺孔塞	Rubber Plug
50	SG11-40121225-05	面板螺钉	Screw Sm3/16x28 L=12
51	SG1281-01-13	面板线钩	Two Hole Thread Guide
52	SG11-70110620-05	左线勾螺钉	Arm Thread Guide Screw Sm11/64x40 L=6
53	SG11-40120925-05	后窗板螺钉	Screw Sm3/16x28 L=9

1. 机壳部件 Frame Components

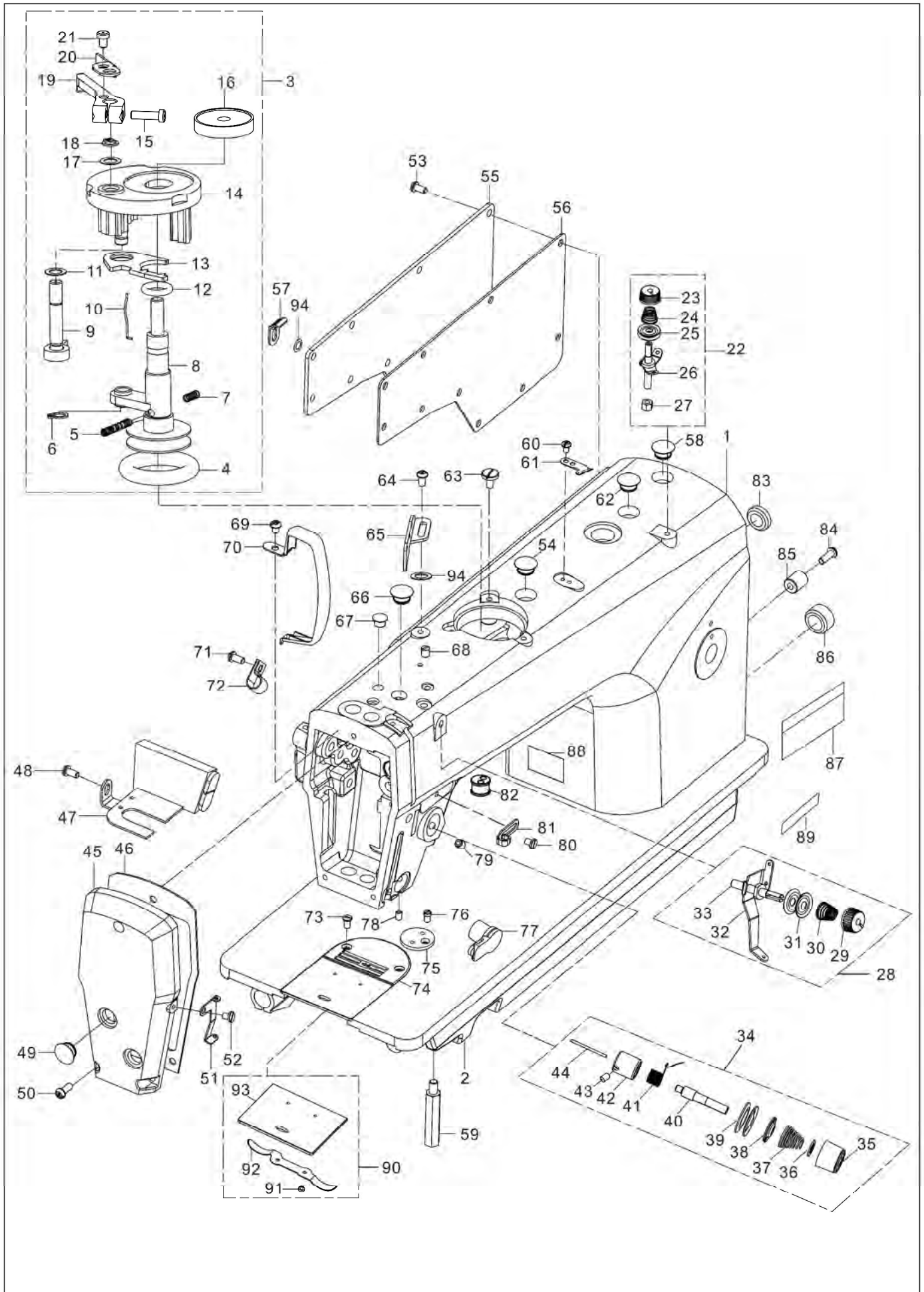



## 1.机壳部件 Frame Components

序号 NO.	图号 REF NO.	名称	DESCRIPTION
54	SG101-01-11	面板调节螺孔塞	Rubber Plug
55	SG1255-01-05	后窗板	Side Plate
56	SG1255-01-06	后窗板垫	Side Plate Guide
57	SG1273-12-05	直角电线夹	Rectangular Wire Clamp
58	SG101-01-11	调同步孔橡皮塞	Rubber Plug
59	SG101-01-15	底板支座	Bed Screw Stud Sm15/64x28
60	SG11-00090620-05	割线刀固定螺钉	Screw Sm9/64x40 L=6
61	SG1281-05-21	割线刀	Thread Cutter
62	SG101-01-11	面板调节螺孔塞	Rubber Plug
63	SG11-70121020-05	绕线器固定螺钉	Screw Sm3/16x28 L=10
64	SG11-40120625-05	三眼过线板螺钉	Screw Sm3/16x28 L=9
65	SG1255-01-15	三眼过线板	Three Thread Eyelet Pate
66	SG101-01-11	面板调节螺孔塞	Rubber Plug
67	SG101-01-12	挑线连杆销孔塞	Rubber Plug
68	SG11-80150710-05	小夹线器固定螺钉	Pre-tension Screw
69	SG11-40120625-05	挑线杆护罩螺钉	Screw Sm3/16x28 L=6
70	SG1281-05-25	挑线杆护罩	Thread Take-up Lever Cover
71	SG12-40500625-02	电线夹固定螺钉	Screw Sm11/64x40 L=8
72	SG1281-05-41	塑料双电线夹	Plastic Double Wire Clamp
73	SG11-20110920-05	针板螺钉	Screw Sm11/64x40 L=9
74	SG109-01-44A	针板	Needle Plate
75	SG101-01-17	安装板	Ruler Stop Seat(261-140342-A)
75	SG1281-05-31	安装板	Ruler Stop Seat(261-140342/261-160362)
76	SG11-00110620-05	安装板定位螺钉	Screw Sm11/64x40 L=5.5
77	SG1281-01-14	电子夹线器	Electric Thread Nipper
78	SG12-80500612-01	电子夹线器固定螺钉	Electric Thread Nipper Screw
79	SG11-80150710-05	大夹线器螺钉	Screw Sm15/64x28 L=7
80	SG11-70110620-05	右线勾螺钉	Arm Thread Guide Screw Sm11/64x40 L=6
81	SG101-03-16	右线勾	Arm Thread Guide (right)
82	SG1281-02-03	三孔橡胶塞	Tripple-hole rubber stopper
83	SG101-01-02	送料调节器孔塞	Rubber Plug
84	SG11-40121425-01	倒缝扳手限位销螺钉	Screw Sm3/16x28 L=14
85	SG1281-01-24	倒缝扳手限位销	Limit Place Bushing
86	SG101-01-03	下轴工艺孔塞	Rubber Plug
87	SG9830 910008 SZ	机身型号牌标签	Model Plate
88	SG0798 446511 DE	警告标签	Warning Label
89	SG9830 910009	中国制造标签	Warning Label
90	SG101-06-39	推板组件	Slide Plate Asm.
91	SG11-60060220-01	推板簧螺钉	Screw Sm3/32x56 L=2
92	SG101-06-40	推板簧	Slide Plate Spring
93	SG101-06-39-1	推板	Slide Plate
94	SG21-05310100-02	后窗板螺钉垫片	Washer

2. 上轴及挑线部件 Main Shaft & Thread Take-up Components

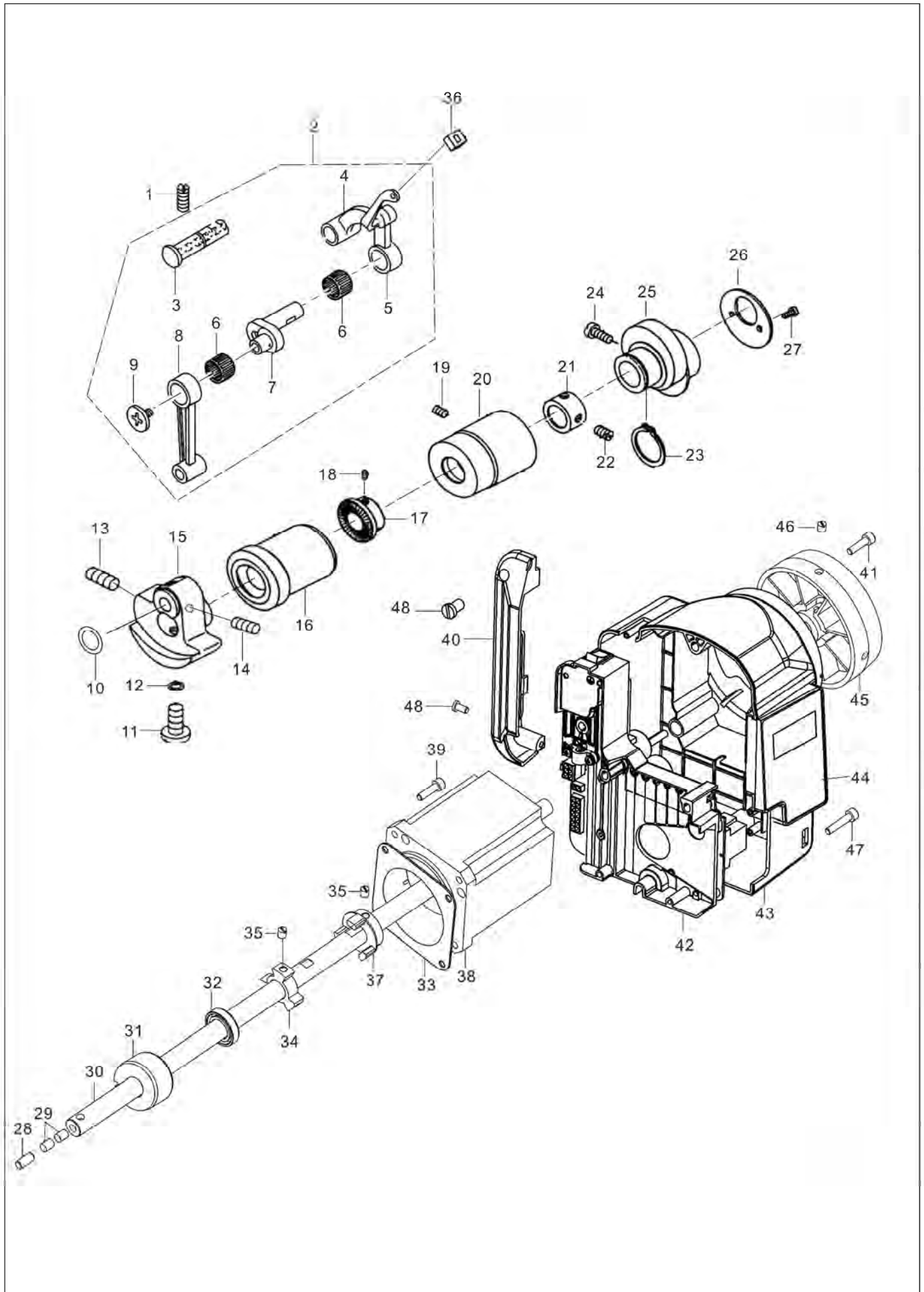

## 2.上轴及挑线部件 Main Shaft & Thread Take-up Components

序号 NO.	图号 REF NO.	名称	DESCRIPTION
1	SG11-80151550-01	挑线连杆销螺钉	Set Screw Sm15/64x28 L=11
2	SG1281-01-30A	挑线杆大组件	Thread Take-up Lever Asm.
3	SG101-02-25	挑线连杆销	Hinge Pin
4	SG101-02-22-05	挑线连杆	Thread Take-up Lever Link
5	SG1281-01-30-01	挑线杆组件	Thread Take-up Lever
6	SG101-02-24	滚针轴承	Needle Bearing
7	SG101-02-20-00	挑线曲柄组件	Thread Take-up Crank
8	SG1281-01-30-02	针杆连杆	Needle Bar Link
9	SG101-02-28	挑线曲柄左旋螺钉	Set Screw (left Handed)
10	SG21-08008160-01	挑线杆垫片	Counter Weight Protecting Plate
11	SG11-60181630-01	针杆曲柄定位螺钉	Screw Sm9/32x28 L=16
12	SG31-04424000-09	定位螺钉形圈	Rubber Ring
13	SG11-80181650-01	针杆曲柄紧固螺钉	Set Screw Sm9/32x28 L=16
14	SG11-80160612-01	针杆曲柄螺钉	Screw Sm1/4x40 L=6
15	SG1281-05-03	针杆曲柄	Needle Bar Crank
16	SG1281-05-04	上轴前轴套组件	Main Shaft Bushing (left)
17	SG1255-02-10	绕线轮	Driving Wheel
18	SG11-80160810-01	绕线轮固定螺钉	Screw Sm1/4x40 L=8
19	SG11-80150710-01	上轴中轴套螺钉	Set Screw Sm15/64x28 L=7
20	SG1255-02-12	上轴中轴套	Main Shaft Bushing (middle)
21	SG101-02-33	上轴挡圈	Thrust Collar Asm D=14.72 W=12
22	SG11-80160710-01	上轴挡圈螺钉	Screw Sm1/4x40 L=7
23	SG25-20000000-08	拾牙连杆轴用挡圈	Snap Ring
24	SG11-00161120-01	送料偏心轮螺钉	Screw Sm1/4x40 L=11
25	SG101-06-02	送料偏心轮	Feed Drive Eccentric Cam
26	SG101-06-04	送料偏心轮盖板	Thrust Collar
27	SG11-10090620-01	送料偏心轮盖板螺钉	Screw Sm9/64x40 L=6
28	SG1281-01-39	上轴油量堵销	Oil Seal Pin
29	SG101-02-11	曲柄油量限制垫	Roller Felt
30	SG1281-05-05	上轴	Main Shaft
31	SG1281-05-06	上轴后套	Supporting Sleeve
32	SG32-13850360-09	上轴油封	Oil Seal
33	SG1255-02-09	电机防油垫	Motor Oil Pad
34	SG1302-12-19	联轴器A	Coupling A
35	SG12-80600812-01	螺钉	Set Screw Socket M6 L=8
36	SG101.02-23	挑线杆防油套	Oil Protect Bushing
37	SG1281-05-08	联轴器B	Coupling B
38	SG1281-05-02-01-02	电机组件	Motor Asm.
39	SG16-60501822-01	电机安装螺钉	Bolt Socket M5 L=18
40	SG1281-05-02A-04	后电线罩	Rear Wire Cover
41	SG12-60501822-01	电控安装螺钉(短)	Bolt Socket M5 L=18
42	SG1281-05-02A-0101	电路板组件	Electronic Control Board
43	SG1281-05-02A-02	电机罩壳	Motor Casing
44	SG1281-05-02A-03	操作面板	Operation Plate
45	SG1281-05-11A	手轮	Hand Wheel
46	SG12-80500612-01	手轮螺钉	Bolt Socket M5 L=6
47	SG12-60502522-01	电控安装螺钉(长)	Bolt Socket M5 L=27
48	SG12-60401220-01	后电线盖板螺钉	Screw Sm3/16x28 L=9

3. 针杆、竖轴、下轴部件 Needle bar, vertical shaft & hook driving shaft components

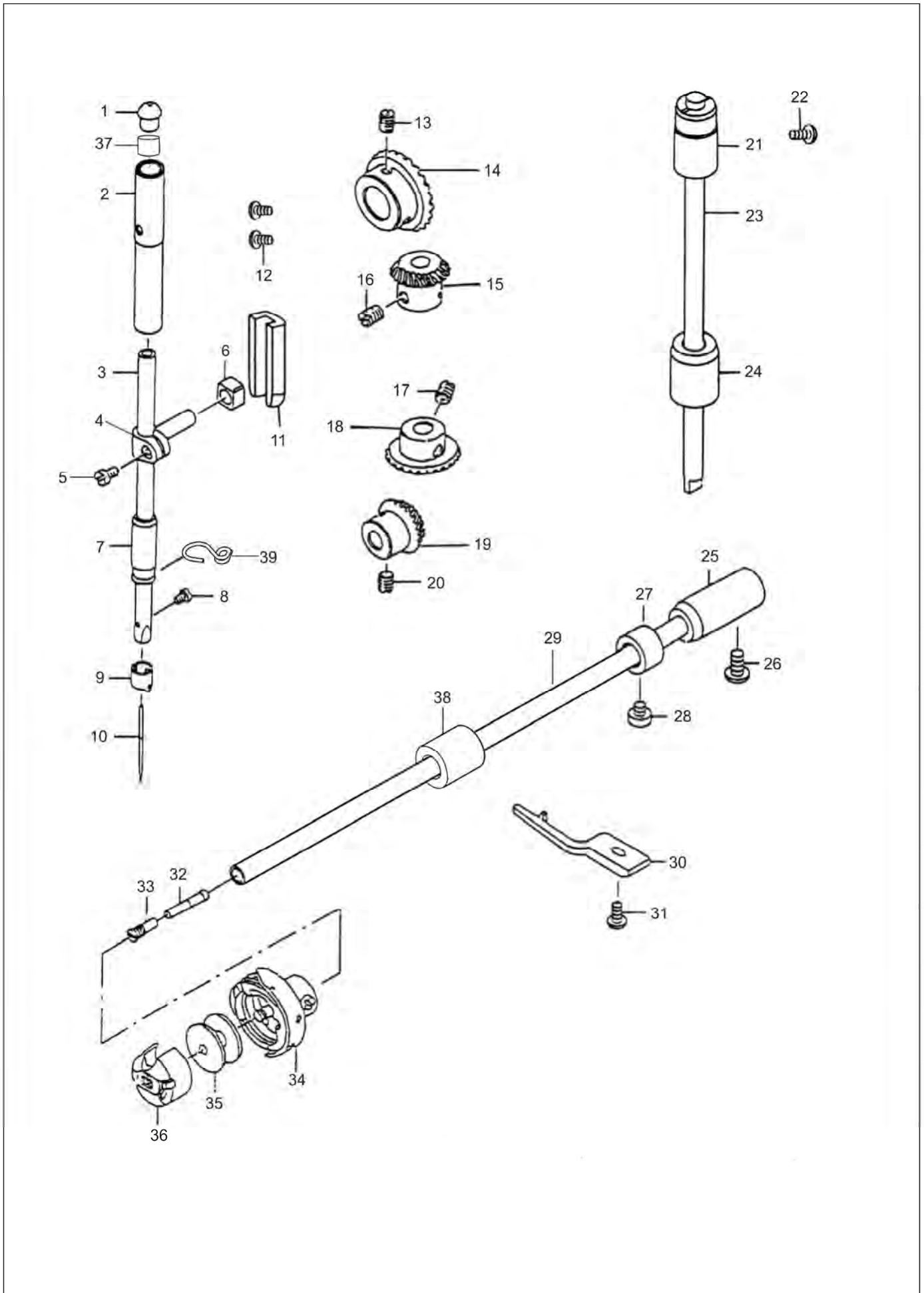

### 3.针杆、竖轴、下轴部件 Needle bar, vertical shaft & hook driving shaft components

序号 NO.	图号 REF NO.	名称	DESCRIPTION
1	SG101-03-07	针杆上衬套孔塞	Rubber Plug
2	SG1281-01-25	针杆上套	Needle Bar Upper Bushing
3	SG1281-01-37	针杆	Needle Bar (261-140342-A)
3	SG1281-05-32H	针杆	Needle Bar (261-160362)
3	SG1281-05-32	针杆	Needle Bar (261-140342)
4	SG120-02-07	针杆连接柱	Needle Bar Connection
5	SG11-60090620-01	针杆连接柱螺钉	Screw Sm9/64x40 L=6
6	SG120-02-25	针杆连接柱滑块	Slide Block
7	SG101-03-08	针杆下轴套	Needle Bar Bushing Lower
8	SG11-60080520-01	机针固定螺钉	Screw Sm1/8x44 L=5
9	SG101-03-11	针杆过线环	Needle Bar Thread Guide
10	SG101-03-13	机针DBX1 14#	Needle DBx1 14# (261-140342-A)
10	SG124-04-24	机针134 Nm90	Needle 134 Nm90 (261-140342)
10	SG101-03-13H	机针134 Nm110	Needle 134 Nm110 (261-160362)
11	SG120-02-23	针杆滑块导轨	Guide For Slide Block
12	SG11-60110820-01	滑块导轨螺钉	Screw Sm11/64x40 L=8
13	SG11-80160810-01	伞齿轮螺钉	Screw Sm1/4x40 L=8
14	SG101-05-26	上轴伞齿轮	Bevel Gear For Arm Shaft
15	SG101-05-25	竖轴上伞齿轮	Bevel Gear For Vertical Shaft
16	SG11-80160810-01	伞齿轮螺钉	Screw Sm1/4x40 L=8
17	SG11-80160810-01	伞齿轮螺钉	Screw Sm1/4x40 L=8
18	SG101-05-20	竖轴下伞齿轮	Bevel Gear For Vertical Shaft
19	SG101-05-18	下轴伞齿轮	Bevel Gear For Hook Shaft
20	SG11-80160810-01	伞齿轮螺钉	Screw Sm1/4x40 L=8
21	SG1281-05-30	竖轴上轴套	Upright Shaft Bushing Upper
22	SG11-40120925-01	竖轴上轴套螺钉	Screw Sm3/16x28 L=9
23	SG101-05-24	竖轴	Vertical Shaft
24	SG101-05-21	竖轴下轴套	Upright Shaft Bushing Lower
25	SG1281-05-31	下轴后轴套	Bushing For Rotating Hook Shaft
26	SG11-40120925-01	下轴后轴套螺钉	Screw Sm3/16x28 L=9
27	SG402-04-21	下轴挡圈	Thrust Collar
28	SG11-80160512-01	下轴挡圈螺钉	Screw Sm1/4x40 L=5
29	SG1230-05-07	下轴	Rotating Hook Shaft
30	SG101-05-05A	旋梭定位钩	Positioning Finger
31	SG11-60111120-01	旋梭定位钩螺钉	Screw Sm11/64x40 L=11
32	SG101-05-09	下轴限油芯	Oil Wick
33	SG101-05-08	下轴限油螺钉	Oil Seal Screw
34	SG109-03-24	旋梭组件	Hook Asm.
35	SG402-04-04	梭心	Bobbin
36	SG0281 150084	梭心套	Bobbin Case
37	SG1280-01-23	针杆上套羊毛毡	Needle Bar Sleeve Wool Felt
38	SG158-05-19	下轴中套	Lower Shaft Middle Sleeve
39	SG1281-05-20	针杆下套过线钩	Needle Bar Thread Guide

4. 压脚部件 Presser bar components

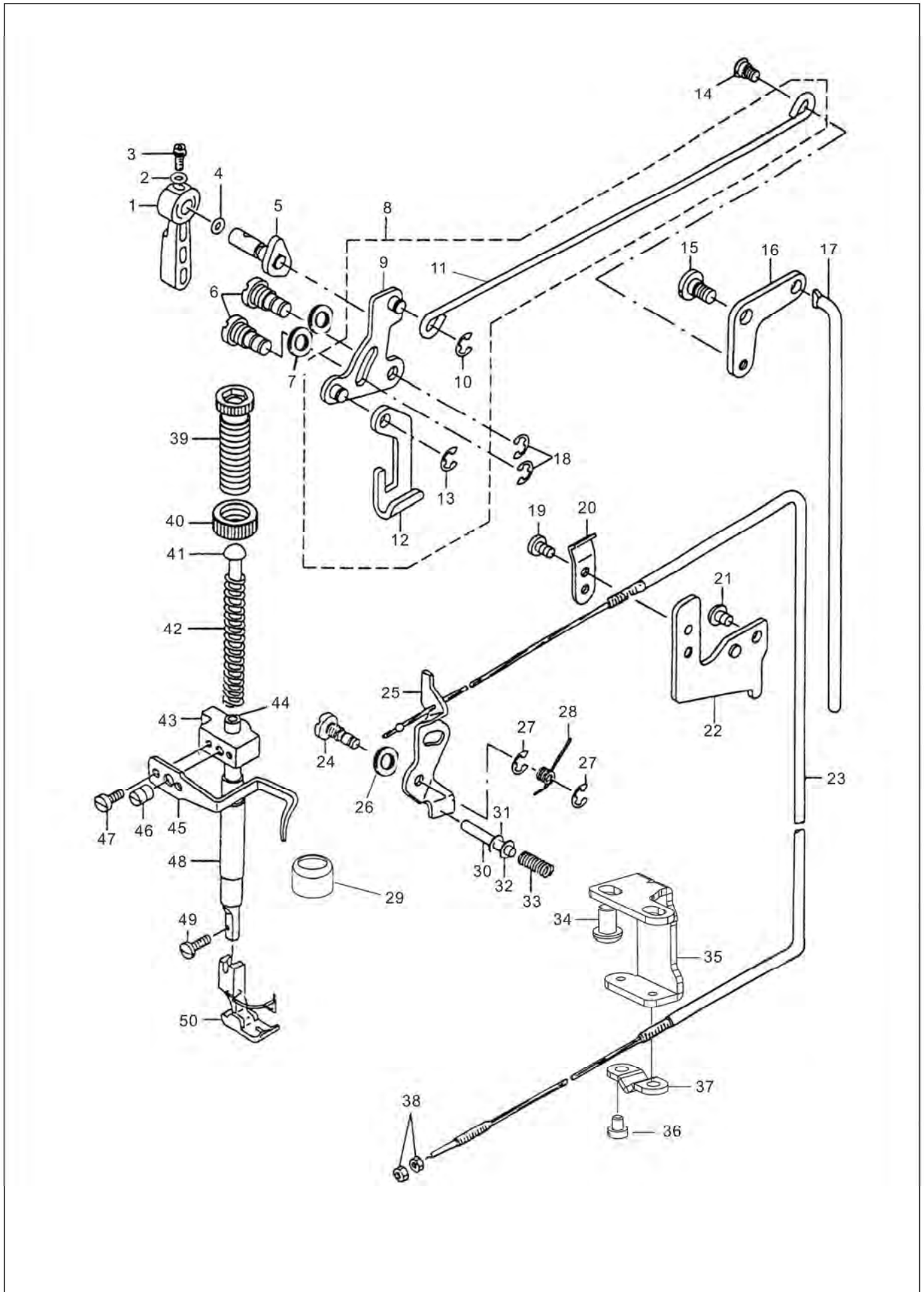

#### 4. 压脚部件 Presser bar components

序号 NO.	图号 REF NO.	名称	DESCRIPTION
1	SG1281-05-15A	压脚扳手	Hand Lifter
2	SG21-03810080-05	压脚扳手螺钉垫圈	Washer
3	SG11-30091020-05	压脚扳手螺钉	Screw Sm9/64x40 L=10
4	SG31-04018000-09	压脚扳手轴O形圈	Rubber Ring
5	SG1281-01-10	压脚扳手凸轮组件	Hand Lifter Cam Asm.
6	SG101-04-20	前杠杆螺纹销	Link Shaft Sm5/16x24
7	SG101-04-21	螺纹销密封垫圈	Washer Plate
8	SG101-04-19	抬压脚杠杆部件	Hand Lifter Link Asm.
9	SG101-04-19-00	抬压脚前杠杆组件	Hand Lifter Link
10	SG24-05000000-08	开口挡圈	Snap Ring
11	SG101-04-28	抬压脚拉杆	Lifting Lever Connecting Rod
12	SG101-04-18	压脚升降板	Lifting Lever
13	SG24-05000000-08	开口挡圈	Snap Ring
14	SG101-04-32	抬压脚拉杆螺钉	Hinge Screw Sm3/16x32
15	SG101-04-31	后杠杆轴位螺钉	Hinge Screw Sm15/64x 28
16	SG101-04-30	抬压脚后杠杆	Lifting Lever Link
17	SG101-04-33	抬压脚顶杆	Connecting Rod Vertical
18	SG24-05000000-08	开口挡圈	E-ring 5
19	SG11-60111020-01	螺钉	Screw Sm11/64x40 L=10
20	SG109-04-18	压板B	Wire Plate B
21	SG11-40120625-01	上电线压板固定螺钉	Screw Sm3/16x28 L=9
22	SG109-04-20-00	上电线压板组件	Wire Holder Bracket Upper
23	SG1230-04-44	制动器组件	Arrester Asm.
24	SG101-04-25	松线顶板螺纹销	Tension Release Shaft
25	SG101-04-24	松线顶板	Tension Release Plate
26	SG101-04-21	螺纹销密封垫圈	Washer Plate
27	SG24-05000000-08	开口挡圈E5	E-ring 5
28	SG1255-04-01	松线顶板复位簧	Thread Tension Release Wire Spring
29	SG101-04-34	压杆防油套	Rubber Bushing
30	SG101-03-30	松线辅钉	Tension Release Supporting Pin
31	SG24-04000000-08	松线辅钉开口挡圈E4	E-ring 4
32	SG101-03-32	松线辅钉垫片	Washer Plate
33	SG101-03-33	松线辅钉弹簧	Tension Release Supporting Pin Spring
34	SG11-40150925-01	下电线压板固定螺钉	Screw Sm15/64x28 L=9
35	SG1230-04-42	下电线压板	Cord Holder
36	SG11-60090820-01	压紧板固定螺钉	Screw Sm9/64x40 L=8
37	SG1230-04-18	下电线压紧板	Wire Holder
38	SG13-60623020-01	松线钢丝螺母	Nut Sm3/16x32
39	SG1281-05-16A-01	调压螺钉	Presser Regulator Screw
40	SG1281-05-16A-02	调压螺母	Presser Regulator Nut
41	SG101-04-03	调压导杆	Presser Guide Bar
42	SG101-04-04	调压簧	Presser Spring
43	SG101-04-06	压杆导架	Presser Bar Guide Bracket
44	SG1281-01-26	压杆	Presser Bar
45	SG1255-04-02	缓线调节钩	Presser Bar Thread Guide
46	SG11-80160810-01	压杆导架螺钉	Screw Sm1/4x40 L=8
47	SG11-40090825-01	缓线调节钩螺钉	Screw Sm9/64x40 L=8
48	SG101-04-10	压杆衬套	Presser Bar Bushing Lower
49	SG11-60091120-05	活压脚螺钉	Presser Foot Screw Sm9/64x40 L=11
50	SG0281 220024	活压脚组件	Presser Foot Asm.

5.送料部件 Feed mechanism components

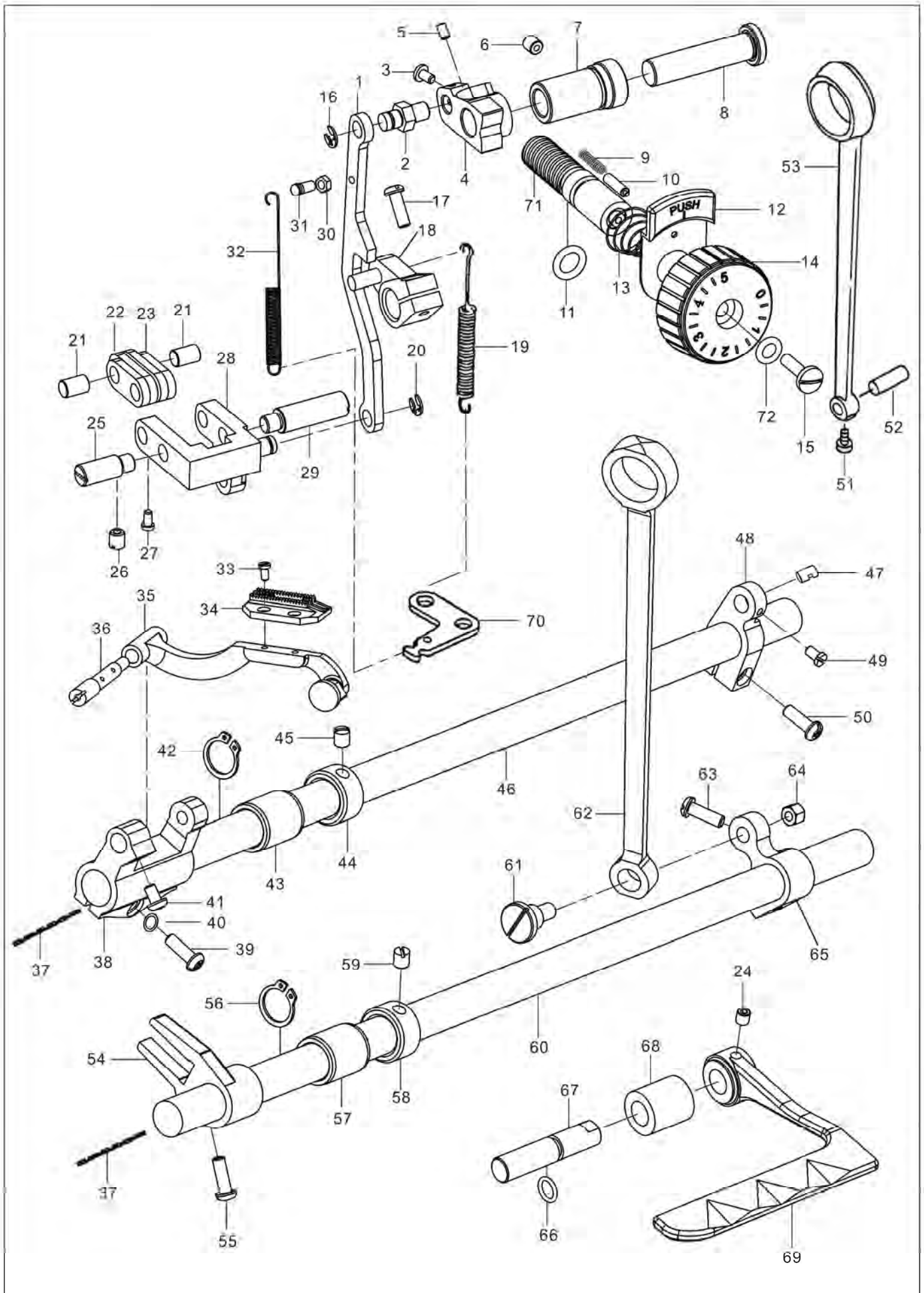



## 5.送料部件 Feed mechanism components

序号 NO.	图号 REF NO.	名称	DESCRIPTION
1	SG1281-01-43	倒送料连杆	Feed Regulator Connecting Rod
2	SG1255-05-09	倒送料连杆销	Feed Regulator Pin
3	SG11-60090620-01	送料连杆销螺钉	Screw Sm9/64x40 L=6
4	SG1255-05-05	送料调节座	Feed Regulator
5	SG12-80500612-01	针距座固定螺钉	Bolt Socket M5 L=6
6	SG11-80150612-01	针距座锁紧套螺钉	Screw Sm15/64x40 L=6
7	SG1255-05-07	送料调节器轴套	Feed Regulator Bushing
8	SG1255-05-06	针距座销	Hinge Pin For Regulator
9	SG124-08-07	送料距锁合簧	Spring
10	SG1273-15-24	针距调节旋钮限位销	Pin
11	SG31-09428000-09	送料调节螺柱O形圈	Rubber Ring
12	SG1273-15-17A	锁针距挡板	Needle Gauge Lock Guide
13	SG120-03-30	送料调节旋钮弹簧	Spring
14	SG1281-05-17A	送料距旋钮	Stitch Length Dial
15	SG11-70121820-01	送料距旋钮螺钉	Screw Sm3/16x28 L=18
16	SG24-05000000-09	开口挡圈	E-ring5
17	SG11-60121420-01	倒送料曲柄螺钉	Feed Reverse Arm Screw Sm3/16x28 L=14
18	SG1273-05-02	倒送料曲柄组件	Feed Reverse Asm.
19	SG101-07-22	倒送料拉簧	Feed Reverse Spring
20	SG24-05000000-09	开口挡圈	E-ring5
21	SG101-06-11	短摆动座连接销	Walking Foot Pin
22	SG101-06-09	送料长摆动板	Walking Foot Link
23	SG101-06-10	送料短摆动板	Connecting Link
24	SG11-80150612-01	倒送料扳手紧固螺钉	Screw Sm15/64x28 L=6
25	SG101-06-14	送料摆动板座左销	Adjusting Link Fulcrum Shaft
26	SG11-80151150-01	左右销固定螺钉螺钉	Screw Sm15/64 L=11
27	SG11-00090620-01	连接销螺钉	Screw Sm9/64x40 L=6
28	SG109-05-27	送料摆动板座	Feed Adjusting Link Asm.
29	SG1230-06-16	送料摆动板座右销	Adjusting Link Fulcrum Shaft
30	SG13-60113020-01	螺母	Nut
31	SG134-05-28	弹簧连接销	Spring Connecting Pin
32	SG1281-05-45	倒送料弹簧	Feed Reverse Spring
33	SG11-60080620-01	送料牙螺钉	Screw Sm1/8x44 L=6
34	SG109-05-33A	送料牙	Feed Dog
35	SG1273-15-01	牙架组件	Feed Bar Asm.
36	SG101-06-32	牙架销	Feed Bar Shaft
37	SG43-10250000-00	油线Φ2.5×1000mm	Oil Wick
38	SG101-06-28	牙架座	Feed Rocker Asm.
39	SG11-60121420-01	牙架座螺钉	Screw Sm11/64x40 L=11
40	SG21-04808080-01	垫圈	Washer
41	SG11-40110725-01	牙架销紧固螺钉	Screw Sm11/64x40 L=7
42	SG25-15000000-08	送料轴轴用挡圈	Retaining Ring
43	SG101-06-26	送料轴轴套	Feed Rocker Shaft Bushing
44	SG101-02-06	送料轴挡圈	Feed Rocker Shaft Collar
45	SG11-80160610-01	送料轴挡圈螺钉	Screw Sm1/4x40 L=6
46	SG1255-06-22	送料轴	Feed Rocker Shaft
47	SG101-06-19	送料曲柄销	Feed Rocker Crank Pin
48	SG101-06-18	送料曲柄	Feed Rocker Shaft Crank
49	SG11-00090620-01	送料曲柄销螺钉	Screw Sm9/64x40 L=6
50	SG11-40121425-01	送料曲柄螺钉	Screw Sm3/16x28 L=14
51	SG11-00090620-01	送料连杆销螺钉	Screw Sm9/64x40 L=6
52	SG101-06-07	送料连杆销	Walking Foot Pin
53	SG101-06-06	送料连杆	Rocker Shaft Connecting Rod

5.送料部件 Feed mechanism components

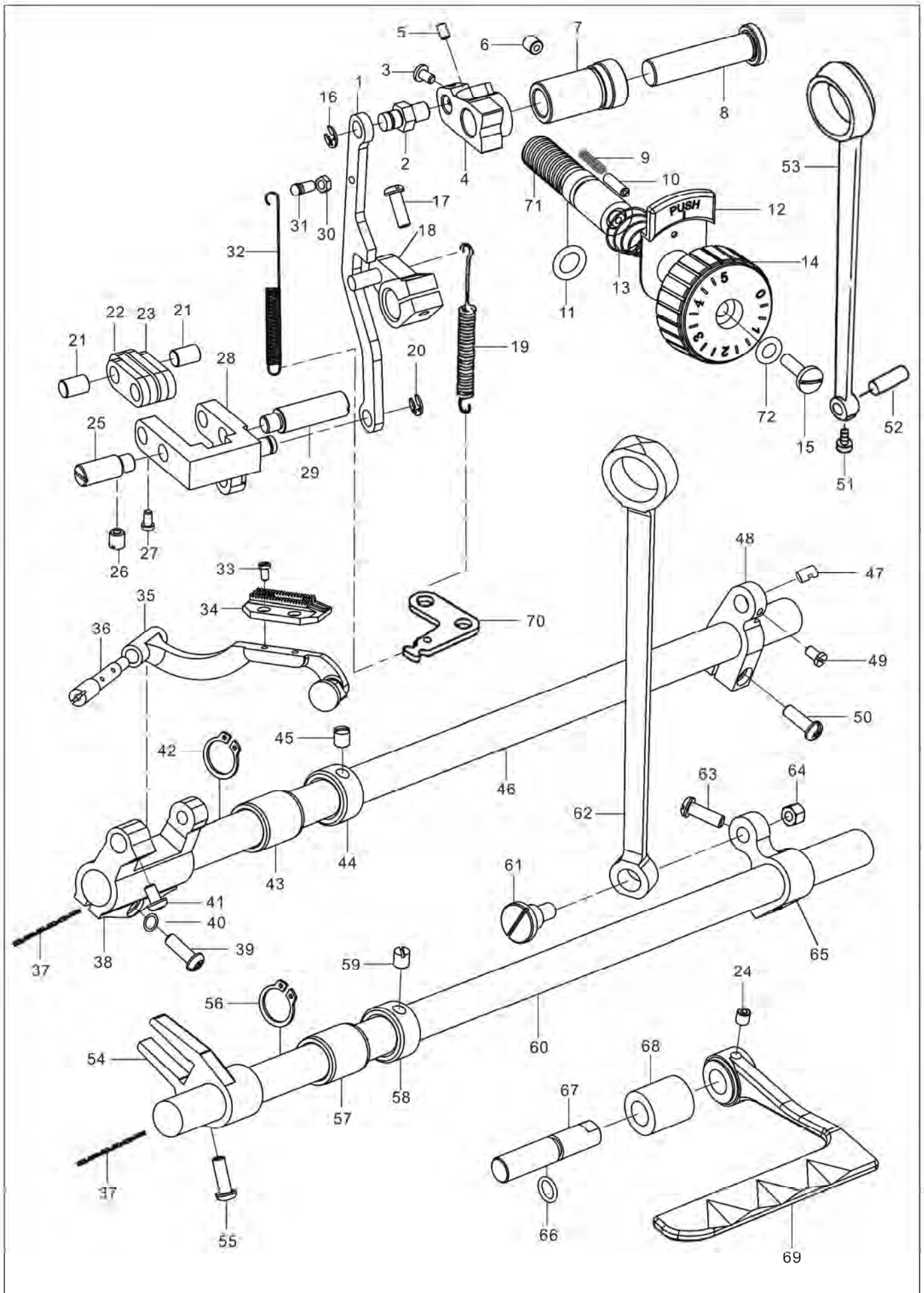

## 5.送料部件 Feed mechanism components

序号 NO.	图号 REF NO.	名称	DESCRIPTION
54	SG101-06-42	拾牙叉形曲柄	Driving Shaft Crank Asm,front
55	SG11-60111120-01	拾牙叉形曲柄螺钉	Screw Sm11/64×40 L=10
56	SG25-15000000-08	拾牙轴轴用挡圈	Retaining Ring
57	SG101-06-26	拾牙轴轴套	Feed Rocker Shaft Bushing
58	SG101-02-06	拾牙轴挡圈	Thrust Collar Asm D=14.72 W=12
59	SG11-80160610-01	拾牙轴挡圈螺钉	Screw Sm1/4×40 L=6
60	SG101-06-44	拾牙轴	Feed Driving Shaft
61	SG101-06-50	拾牙连杆轴位螺钉	Hinge Screw
62	SG101-06-49	拾牙连杆	Connecting Rod
63	SG11-40121225-01	拾牙曲柄螺钉	Screw Sm3/16x28 L=12
64	SG13-60184020-01	拾牙连杆轴位螺母	Hinge Nut Sm9/32x28
65	SG101-06-47	拾牙曲柄	Feed Rocker Crank
66	SG31-08018000-09	倒送料轴O形圈	Rubber Ring
67	SG1255-05-04	倒送料轴	Feed Reverse Shaft
68	SG1255-05-03	倒送料轴套	Feed Reverse Bushing
69	SG1281-01-09	倒缝扳手	Reverse Feed Control Lever
70	SG101-07-23	拉簧固定板	Feed Spring Hook
71	SG1281-01-11	送料调节螺杆	Feed regulator screw
72	SG21-05310100-02	针距标盘螺钉垫片	Washer

6.切线装置部件 Thread trimmer components

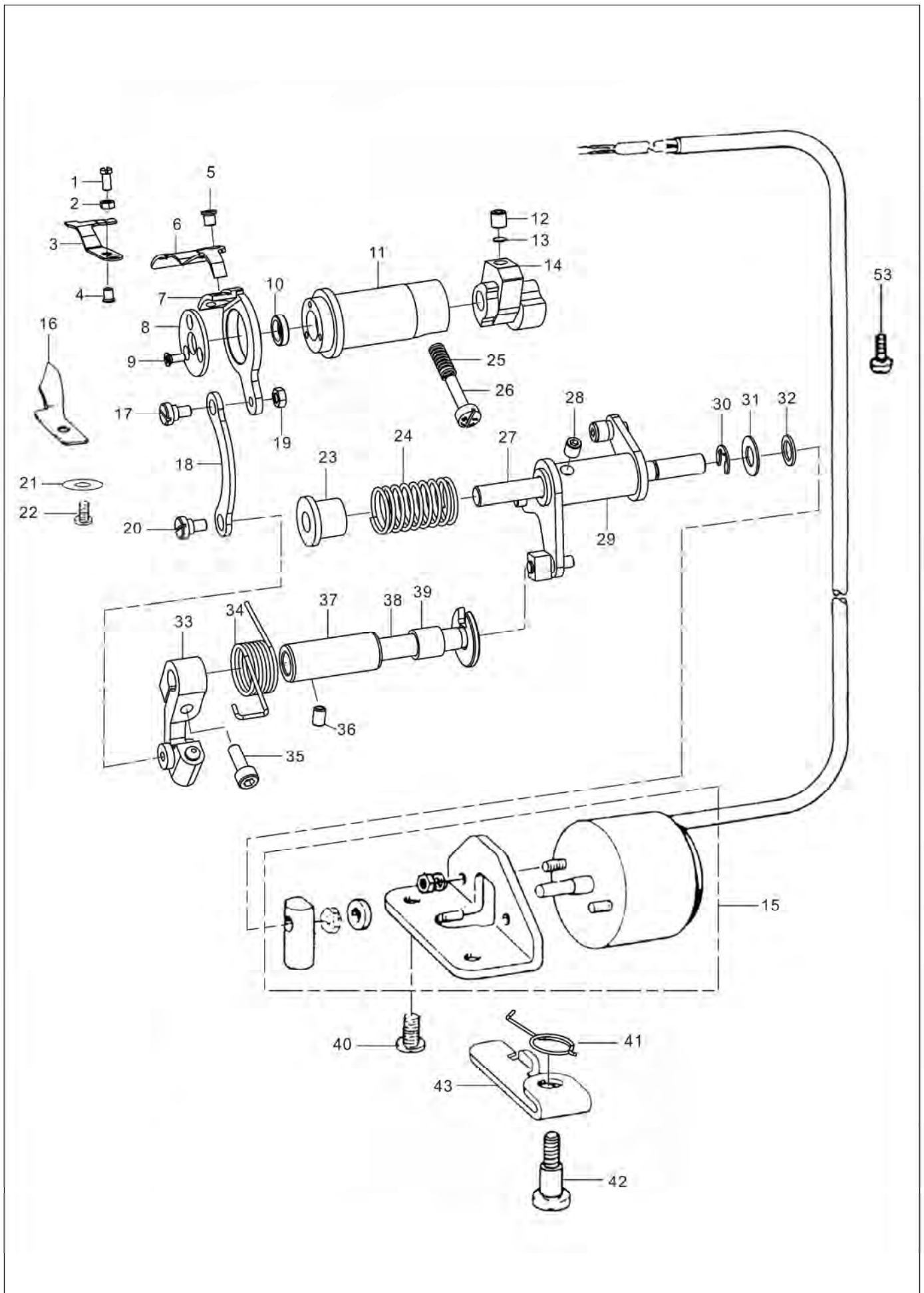

## 6.切线装置部件 Thread trimmer components

序号 NO.	图号 REF NO.	名称	DESCRIPTION
1	SG11-00580720-02	定刀调节螺钉	Screw Sm1/8x40 L=7
2	SG13-60582420-02	定刀压力调节螺母	Nut Sm1/8x40
3	SG158-09-04	固定刀	Fixed Knife
4	SG11-20090520-01	固定刀螺钉	Screw Sm9/64×40 L=5
5	SG11-10110622-01	动刀螺钉	Screw Sm11/64x40 L=6
6	SG158-09-13	动刀	Moving Knife
7	SG1255-06-01-02	动刀架	Knife Bracket
8	SG1255-06-01-03	动刀架压板	Knife Bracket Presser
9	SG12-10300821-01	动刀架压板紧固螺钉	Screw M3 L=8
10	SG32-07430120-09	骨架油封	Oil Seal
11	SG1255-06-01-01	下轴前套	Hook Driving Shaft Bushing Asm.
12	SG11-80161012-01	剪线凸轮固定螺钉	Set Screw1/4×40 L=10
13	SG1230-09-40	剪线凸轮螺钉垫片	Washer
14	SG158-09-01	切线凸轮	Thread Shear Cam
15	SG1281-01-27	剪线电磁铁组件	Solenoid Unit
16	SG1230-09-06	分线器	Thread Partition
17	SG135-06-22	刀轴连杆螺钉	Screw
18	SG1230-09-15	刀轴连杆	Knife Shaft Connecting Rod
19	SG13-60113020-01	刀轴连杆螺母	Nut Sm11/64x40
20	SG135-06-22	刀轴连杆螺钉	Screw
21	SG21-04308090-01	垫圈	Washer
22	SG11-40090625-01	分线器固定螺钉	Screw Sm9/64x40 L=6
23	SG158-09-31	扭簧端盖	Spring Cover
24	SG158-09-32	切线凸轮复位簧	Spring
25	SG113-06-22	旋梭油量调节簧	Oil Adjusting Spring
26	SG113-06-21	旋梭油量调节螺钉	Oil Adjusting Screw
27	SG158-09-30	切刀驱动轴	Thread Shear Shaft
28	SG11-80160612-01	剪线驱动轴固定螺钉	Screw Sm1/4×40 L=10
29	SG158-09-26-00	切线凸轮曲柄大组件	Thread Shear Cam Rock Arm Asm.
30	SG24-06000000-08	挡圈E6	Retaining Ring ,e6
31	SG21-08210162-03	剪线电磁铁垫片	Washer
32	SG101-04-21	电磁铁缓冲垫	Magnetic Plug Cushion Mat
33	SG1230-09-18-00	切刀驱动曲柄组件	Thread Shear Rock Arm
34	SG158-09-21	切刀驱动曲柄弹簧	Spring
35	SG11-60621422-01	驱动曲柄螺钉	Screw Sm3/16×32 L=14
36	SG11-80120712-01	剪线驱动轴套螺钉	Screw Sm3/16x28 L=7
37	SG158-09-24	切线驱动轴套	Thread Shear Shaft Bush
38	SG158-09-22	切刀驱动曲柄轴	Thread Shear Rock Arm Shaft
39	SG158-09-23	驱动曲柄轴短套	Short Bush
40	SG11-40150925-01	剪线电磁铁固定螺钉	Screw Sm15/64×28 L=9
41	SG158-11-11	松线复位弹簧	Spring
42	SG158-09-42	松线座螺钉	Screw
43	SG158-11-01	松线座	Thread Loose Seat

7.自动倒送料部件 Automatic Reverse Feed Components

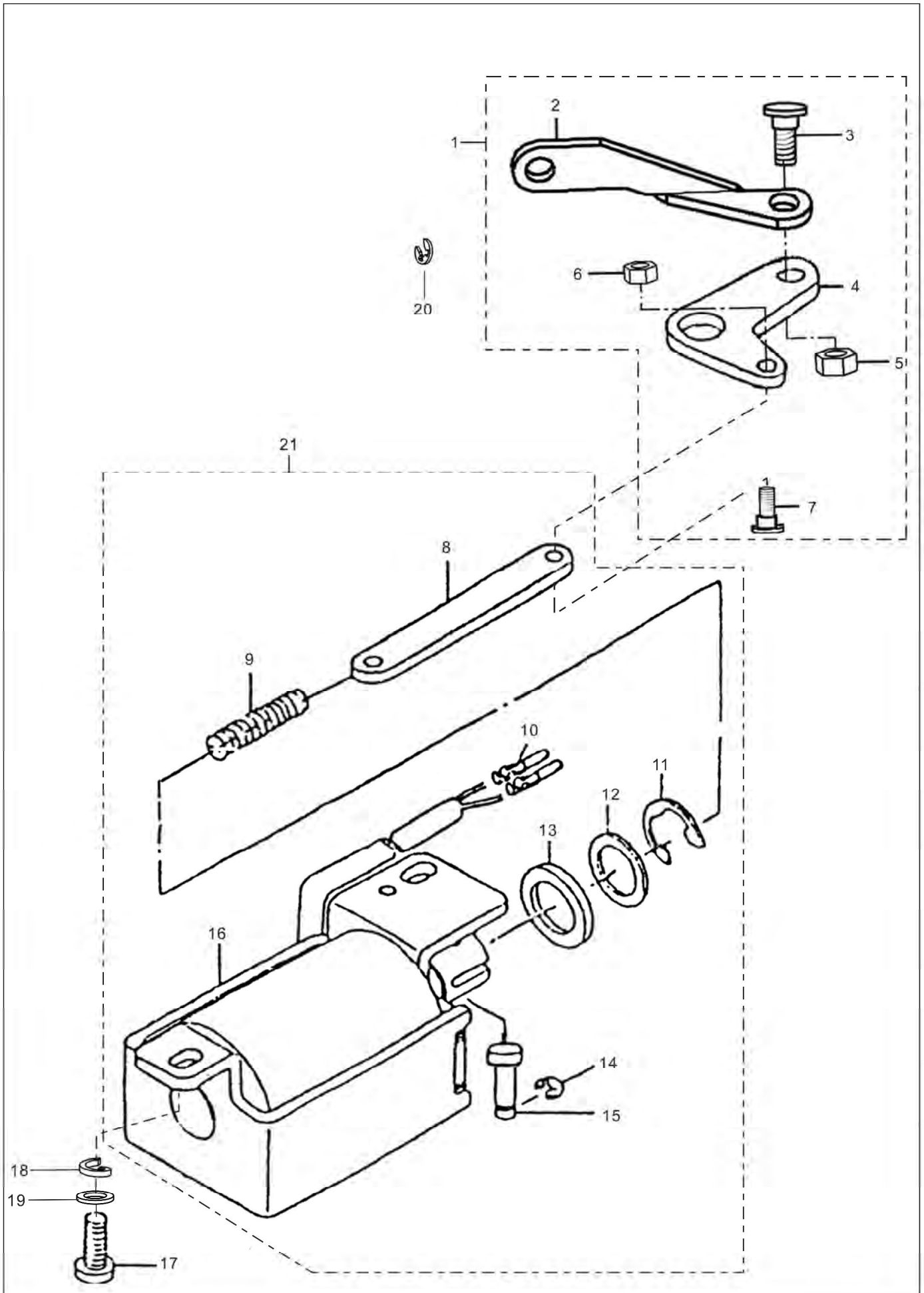

## 7.自动倒送料部件 Automatic Reverse Feed Components

序号 NO.	图号 REF NO.	名称	DESCRIPTION
1	SG109-07-15-00	倒送料连接杆组件	Reverse Feed Connecting Rod Asm.
2	SG109-07-15-01	倒送料连接杆	Reverse Feed Connecting Rod
3	SG109-07-15-03	连接杆轴位螺钉	Connecting Rod Axial Screw
4	SG109-07-15-02	连接臂	Connecting Arm
5	SG13-60157020-01	六角螺母	Nut Sm15/64x28
6	SG13-60113020-01	六角螺母	Nut Sm11/64x40
7	SG109-07-15-04	连接臂轴位螺钉	The Connecting Arm Axial Screw
8	SG109-07-19	倒送料连接片	Feed Reverse Connecting Cover
9	SG109-07-28	柱塞簧	Plunger Spring
10	SG109-07-29	联接插针	Pin Connect
11	SG24-12000000-08	开口挡圈	E-ring 12
12	SG21-16030240-02	垫圈	Washer
13	SG109-07-22	橡胶垫圈	Rubber Washer
14	SG24-04000000-08	开口挡圈	E-ring 4
15	SG109-07-30	倒缝电磁铁销	Pin For Plunger Rod
16	SG1281-01-28-01	倒缝电磁铁	Reverse Feed Solenoid Asm.
17	SG11-60151522-01	倒缝电磁铁固定螺钉	Screw Sm15/64x28 L=9
18	SG21-06115130-01	倒缝电磁铁螺钉垫片	Reverse Feed Solenoid Screw Gasket
19	SG22-06000000-08	倒缝电磁铁弹簧垫圈	Reverse Feed Solenoid Spring Washer
20	SG24-05000000-09	开口挡圈E5	E-ring 5
21	SG1281-01-28	倒缝电磁铁组件	Reverse Feed Solenoid Asm.

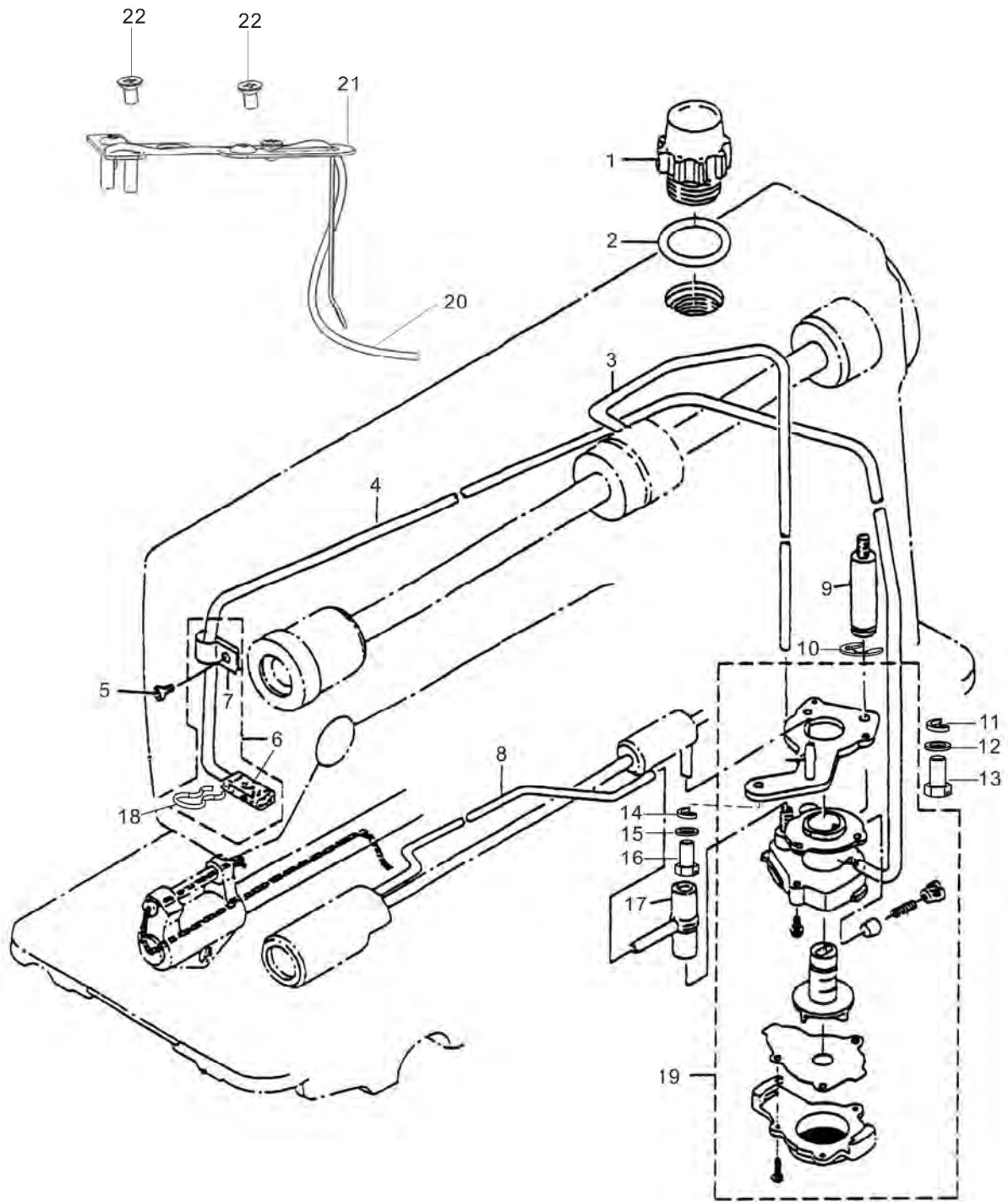



## 8. 润滑部件 Oil Lubrication Components

序号 NO.	图号 REF NO.	名称	DESCRIPTION
1	SG109-09-01	油窗	Oil Sight Window
2	SG31-20024000-09	油窗O形圈	Rubber Ring
3	SG1255-08-19	上轴供油管	Main Shaft Oil Tube
4	SG42-05003000-00A	回油管	Oil Return Tube
5	SG11-40120625-01	回油管夹螺钉	Screw Sm3/16x28 L=6
6	SG120-07-07	机头回油毡	Oil Return Tube Plate Asm.
7	SG101-08-28	回油管夹	Oil Return Tube Holder
8	SG1230-08-20	旋梭轴供油管	Oil Tube
9	SG109-09-25	油泵连接螺柱	Oil Pump Support M8
10	SG24-09000000-08	开口挡圈E9	Snap Ring E9
11	SG22-05000000-08	弹簧垫圈	Spring Washer
12	SG21-04608080-01	螺柱连接螺钉垫圈	Washer For Stud Connecting Screw
13	SG11-90111220-01	螺柱连接螺钉	Screw Sm11/64x40 L=12
14	SG22-06000000-08	弹簧垫圈	Spring Washer
15	SG21-06210101-01	油泵安装螺钉垫圈	Washer For Oil Pump Screw
16	SG11-90151420-01	油泵安装螺钉	Screw Sm15/64x28 L=11
17	SG101-08-18	供油管接头	Rubber Joint
18	SG101-08-33	回油管固定夹	Oil Feet Presser
19	SG101-08-01-00	油泵组件	Lubricating Oil Pump Asm.
20	SG43-10250000-00	油线	Oil Wick
21	SG1280.01-10	油线架组件	Oil Braid Fitting Plate
22	SG11-40091325-01	油线架固定螺钉	Screw Sm9/64x40 L=8

9.油盘、膝抬压脚部件 Oil Reservoir & Knee Lifter Components

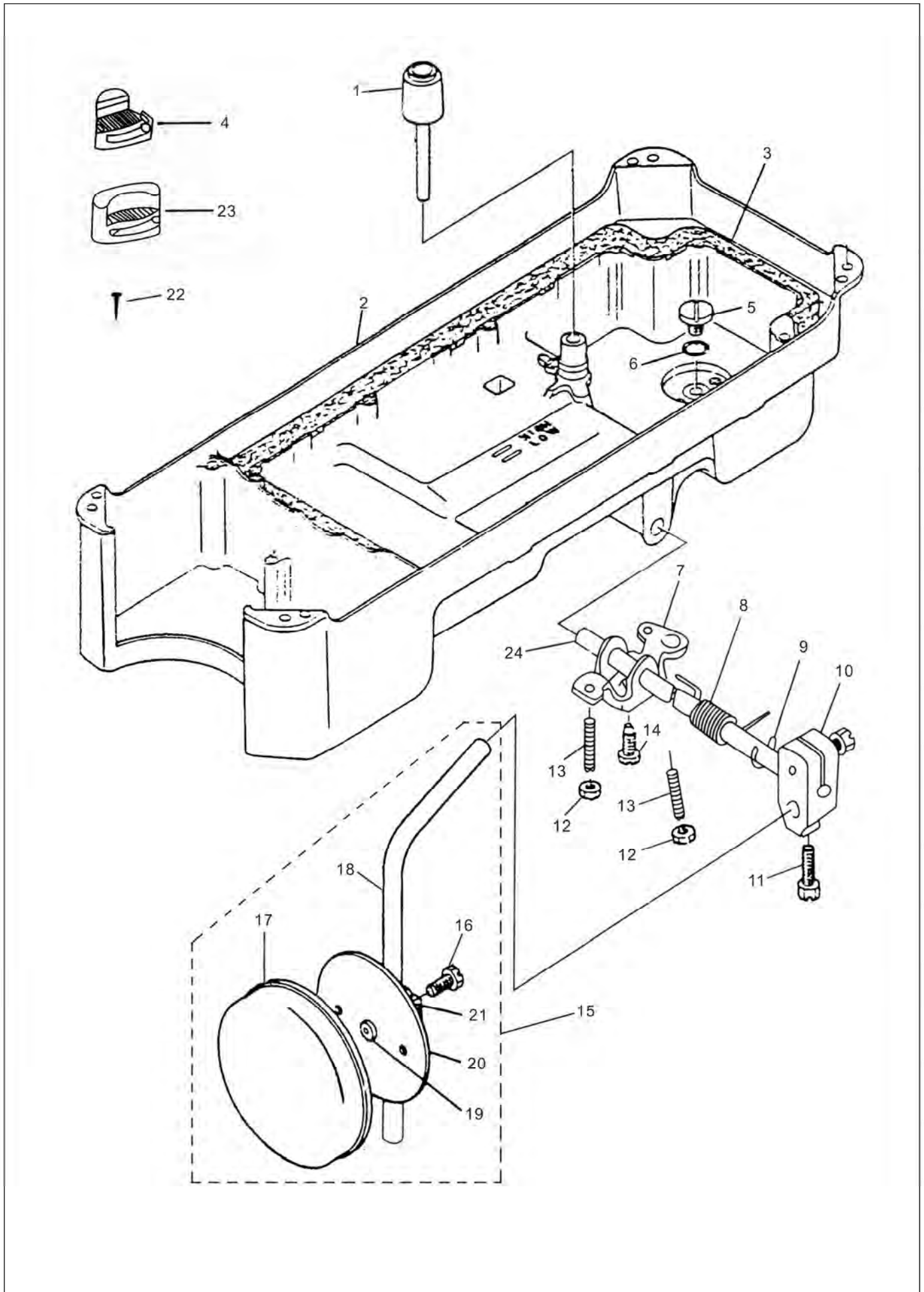

## 9.油盘、膝抬压脚部件 Oil Reservoir & Knee Lifter Components

序号 NO.	图号 REF NO.	名称	DESCRIPTION
1	SG101-09-02	抬压脚顶销	Knee Press Lifter Rod
2	SG101-09-01	油盘	Oil Reservoir
3	SG101-09-03	油盘衬垫	Oil Reservoir Gasket
4	SG120-09-05	油盘支座(小)	Rubber Cushion(small)
5	SG11-70200720-01	排油孔螺钉	Screw Sm5/16x24 L=7
6	SG31-06224000-09	油塞螺钉O形密封圈	Rubber Ring
7	SG101-09-07	抬压脚双向曲柄	Connecting Rod Vertical
8	SG101-09-08	抬压脚曲柄簧	Spring
9	SG24-10000000-09	抬压脚轴开口挡圈	E-ring 10
10	SG101-09-10-00	抬压脚操纵杆接头组件	Knee Press Rod Bearing Bracket Asm
11	SG12-90801423-02	抬压脚操纵杆接头螺钉	Screw M8x14
12	SG14-60603320-02	限位调节螺母	Nut M6
13	SG12-80603050-02	限位调节螺钉	Screw M6 L=30
14	SG12-90601633-02	抬压脚双向曲柄螺钉	Screw M6 L=16
15	SG101-09-15-00	操纵杆组件	Knee Lifter Plate Rod Asm
16	SG101-09-16	操纵杆夹头螺钉	Screw Sm15/64x28 L=15
17	SG101-09-20	操纵板软垫	Knee Press Plate Asm.
18	SG101-09-15	操纵杆	Knee Press Plate Rod
19	SG101-09-18	操纵杆垫块	Knee Press Plate Rubber
20	SG101-09-19	操纵板	Knee Press Plate
21	SG101-09-17	操纵杆夹头	Knee Press Plate Holder
22	SG101-12-03	油盘座钉	Nail
23	SG120-09-04	油盘支座(大)	Rubber Cushion(big)
24	SG101-09-06	膝抬压脚轴	Knee Press Rod

10.线架部件 Thread Stand Components

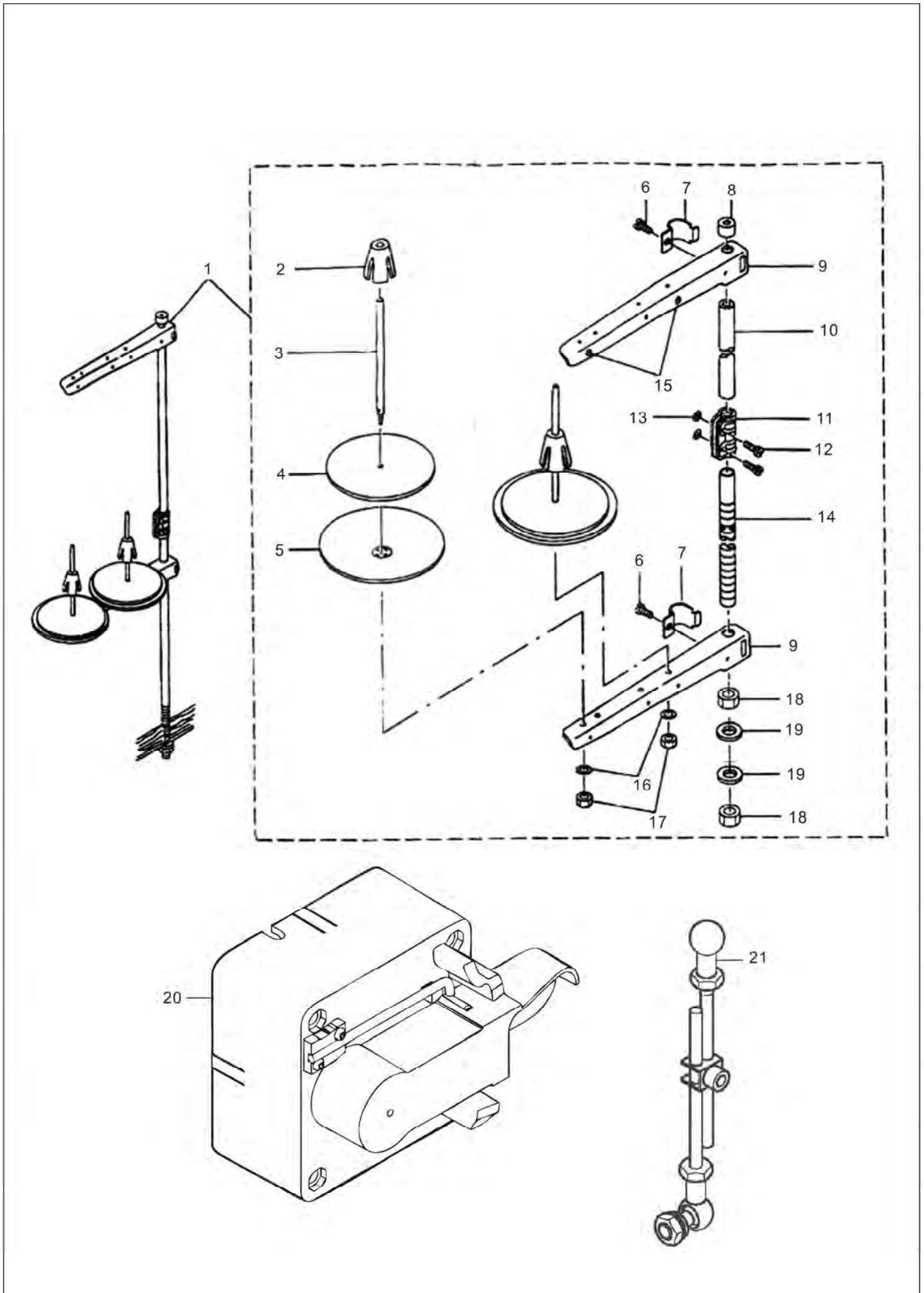

## 10.线架部件 Thread Stand Components

序号 NO.	图号 REF NO.	名称	DESCRIPTION
1	SG101-11-01	线架组件	Thread Stand Asm.
2	SG279-12-00-22	线盘芯	Spool Retainer
3	SG279-12-00-23	线盘钉	Spool Pin
4	SG279-12-00-24	线盘垫	Spool Rest Cushion
5	SG279-12-00-25	线圈托盘	Spool Rest
6	SG279-12-00-04	螺钉	Screw M6 L=18
7	SG279-12-00-03	线臂抱攀	Thread Guide Arm Joint
8	SG279-12-00-01	上直管盖帽	Spool Rest Rod Rubber Cap
9	SG279-12-00-08	短固线臂	Spool Rest Arm
10	SG279-12-00-02	线架上直管	Spool Rest Rod,upper
11	SG279-12-00-15	直管接头	Spool Rest Rod Joint
12	SG279-12-00-16	螺钉	Screw M5 L=16
13	SG279-12-00-14	螺帽	Nut M5
14	SG279-12-00-19	线架下直管	Spool Rest Rod,lower
15	SG279-12-00-07	引线圈	Thread Guide
16	SG279-12-00-26	弹性垫圈	Spring Washer
17	SG279-12-00-27	螺帽	Nut M5
18	SG279-12-00-20	螺帽	Nut M16x1.5
19	SG279-12-00-21	防震垫	Washer 16.1x30x2.6
20	SG1278-17-01-03	脚踏板组件	Proximity switch
21	SG1281-05-02-01-03	脚踏拉杆	Pedal linkage

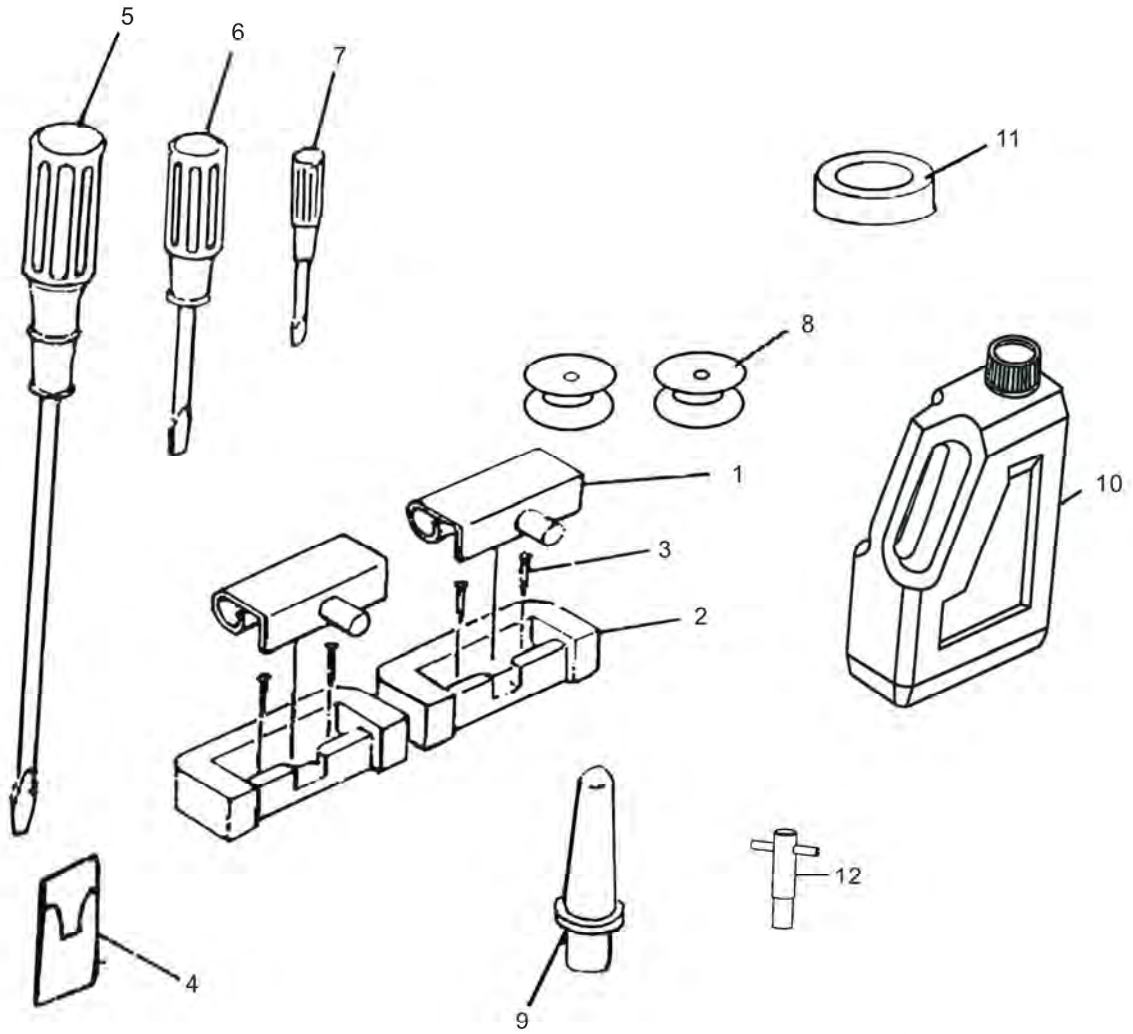

## 11.附件 Accessories

序号 NO.	图号 REF NO.	名称	DESCRIPTION
1	SG101-12-01	机头铰链	Head Connecting Hook
2	SG120-09-02	机头铰链座	Head Connecting Hook Socket
3	SG101-12-03	鞋钉	Head Connecting Hook Nail
4	SG101-03-13	机针 DBX1 14#	Needles DBx1 14#(261-140342-A)
4	SG124-04-24	机针 134 Nm90	Needles 134 Nm90(261-140342)
4	SG101-03-13H	机针 134 Nm110	Needles 134 Nm110(261-160362)
5	SG101-12-15	螺丝刀 (大)	Screw Driver (l)
6	SG101-12-16	螺丝刀 (中)	Screw Driver (m)
7	SG101-12-17	螺丝刀 (小)	Screw Driver (s)
8	SG402-04-04	梭心	Bobbin
9	SG101-12-19	机头支柱	Head Pole
10	SG101-12-21	油箱	Oil Bottle With Oil
11	SG101-09-22	油盘磁铁	Oil Reservoir Magnet
12	SG1277-14-02	套筒扳手	Spanner

12. 厚料大旋梭部件 Heavy duty big hook components (261-160362)

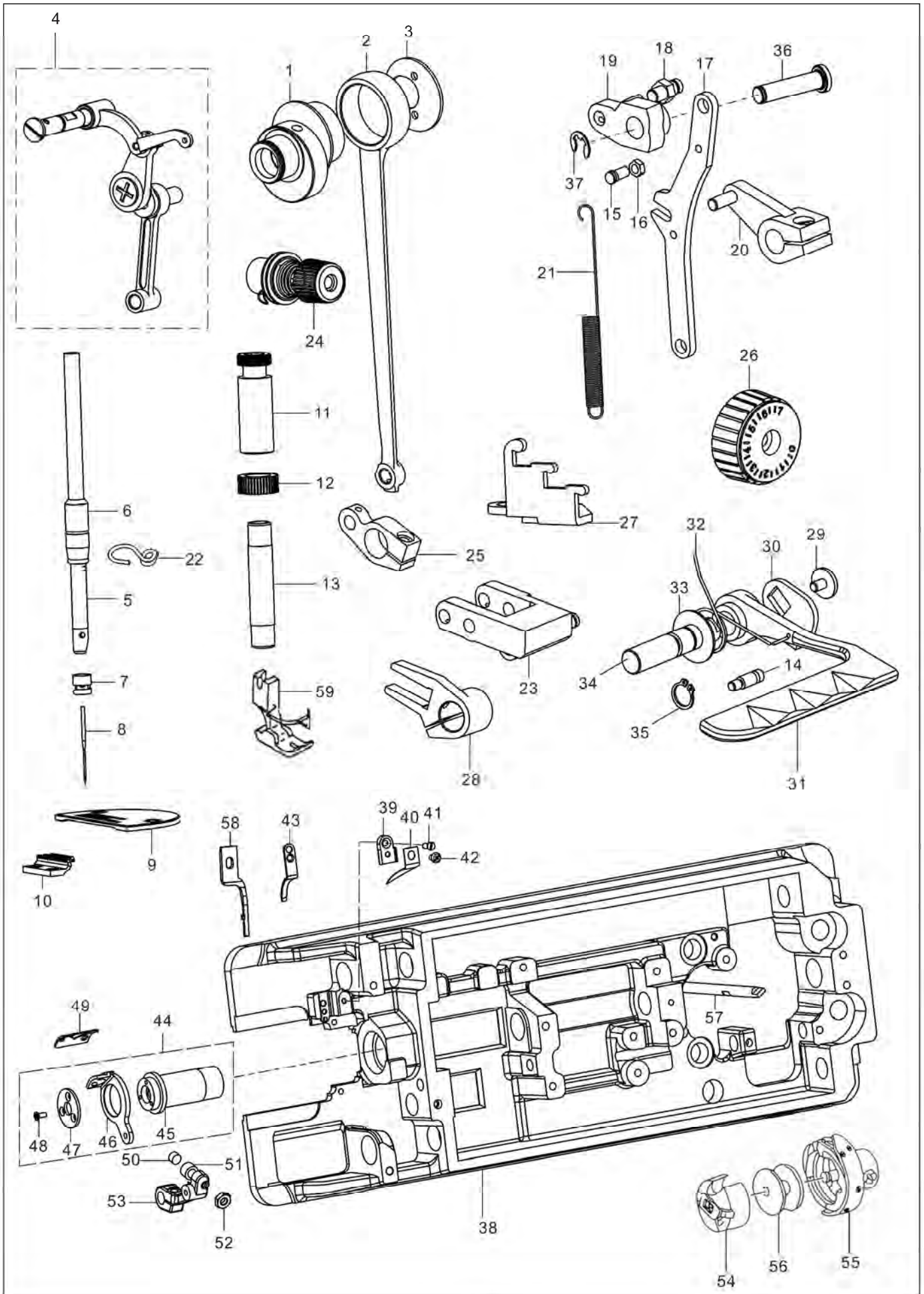



## 12.厚料大旋梭部件 Heavy duty big hook components (261-160362)

序号 NO.	图号 REF NO.	名称	DESCRIPTION
1	SG101-06-02XH	送料偏心轮	Feed Drive Eccentric Cam
2	SG101-06-06XH	送料连杆	Rocket Shaft Connecting Rod
3	SG101-06-04XH	送料偏心轮盖板	Thrust Collar
4	SG1281-01-32	挑线杆大组件	Thread Take-up Lever Asm.
5	SG1281-05-32H	针杆	Needle Bar
6	SG101-03-08XH	针杆下轴套	Needle Bar Bushing Lower
7	SG1277-03-02H	针杆过线环	Needle Bar Thread Guide
8	SG101-03-13H	机针 134 Nm110	Needle 134 Nm110
9	SG101-06-36H	针板 B20	Needle Plate B20
10	SG120-04-04	牙齿	Feed Dog
11	SG101-04-01XH	调压螺钉	Presser Regular Screw
12	SG101-04-02XH	调压螺母	Presser Regular Nut
13	SG101-04-10XH	压杆衬套	Presser Bar Bushing Lower
14	SG1281-01-41	倒缝扳手复位弹簧固定销	Pin
15	SG1281-01-22	弹簧连接销	Spring Connecting Pin
16	SG13-60113020-01	螺母	Hinge Screw
17	SG1273-05-06	倒送料连杆	Feed Regulator Connecting Rod
18	SG101-07-10A	倒送料连杆销	Feed Regulator Pin
19	SG1273-15-04	送料调节器	Feed Regulator
20	SG1273-15-05	倒送料曲柄组件	Feed Reverse Asm.
21	SG1273-15-03	倒送料弹簧	Feed Reverse Spring
22	SG1281-05-20H	针杆下套线钩	Needle Bar Thread Guide
23	SG1273-15-07	送料摆动板座组件	Walking Foot Adjusting Link Asm.
24	SG1281-05-12AH	夹线器组件	Tension Asm.
25	SG101-06-18XH	送料曲柄	Feed Rocker Shaft Crank
26	SG1281-05-17H	送料距旋钮	Feeding From The Knob
27	SG101-07-23XH	弹簧固定板	Spring Plate
28	SG1273-15-02	抬牙叉形曲柄	Driving Shaft Crank Asm, front
29	SG423-06-45	倒送料轴端螺钉	Feed Reverse Screw
30	SG1273-15-08	倒缝扳手板	Reverse Feed Control Lever Link
31	SG1281-01-09A	倒缝扳手	Reverse Feed Control Lever
32	SG1273-15-12	倒缝扳手支撑弹簧	Reverse Feed Control Lever Support
33	SG21-12110262-03	垫圈	Ring
34	SG1273-15-09	倒送料轴	Washer
35	SG25-12000000-08	轴用弹性挡圈	Feed Reverse Shaft
36	SG1273-15-25	针距座销	Hinge Pin For Regulator
37	SG24-09000000-09	针距座销卡簧	E-ring 9
38	SG1273-16-01	底板	Baseboard
39	SG1273-16-04	分线器垫片	Distributor Spacer
40	SG1300-08-05	分线器	Distributor
41	SG11-10090920-01	分线器垫片螺钉	Distributor Spacer Screw
42	SG11-40090525-01	分线器螺钉	Thread Partition Screw
43	SG1273-16-06	定刀	Counter Knife
44	SG1255-06-01B	动刀架前轴套组件	Moterial Knife Bracket Front Shaft Sleeve
45	SG1255-06-01-01	下轴前套	Hook Driving Shaft Bushing Asm.
46	SG1273-16-03	动刀架	Moterial Knife Bracket
47	SG1255-06-01-03	动刀架压板	Moterial Knife Bracket Presser
48	SG12-10300821-01	动刀架压板紧固螺钉	Screw M3 L=8
49	SG1273-16-07	动刀	Moterial Knife
50	SG1277-08-19	凸轮左曲柄缓冲垫	Cam Left Crank Cushion
51	SG1277-08-18	凸轮左曲柄缓冲垫螺钉	Cam Left Crank Cushion Screw
52	SG13-60153020-01	缓冲垫螺钉锁紧螺母	Cushion Nut
53	SG1273-16-02	切刀驱动曲柄	Thread Shear Rock Arm
54	SG1222-05-02	梭芯套	Bobbin Case
55	SG1281-05-27	旋梭	Hook
56	SG1222-05-03	梭芯	Bobbin
57	SG101-05-24B	竖轴	Vertical shaft
58	SG1281-05-18	旋梭定位钩	Positioning finger
59	Q281 220034	压脚组件	Presser Foot Asm.

13. 内置抬压脚部件 Built-in presser foot Components

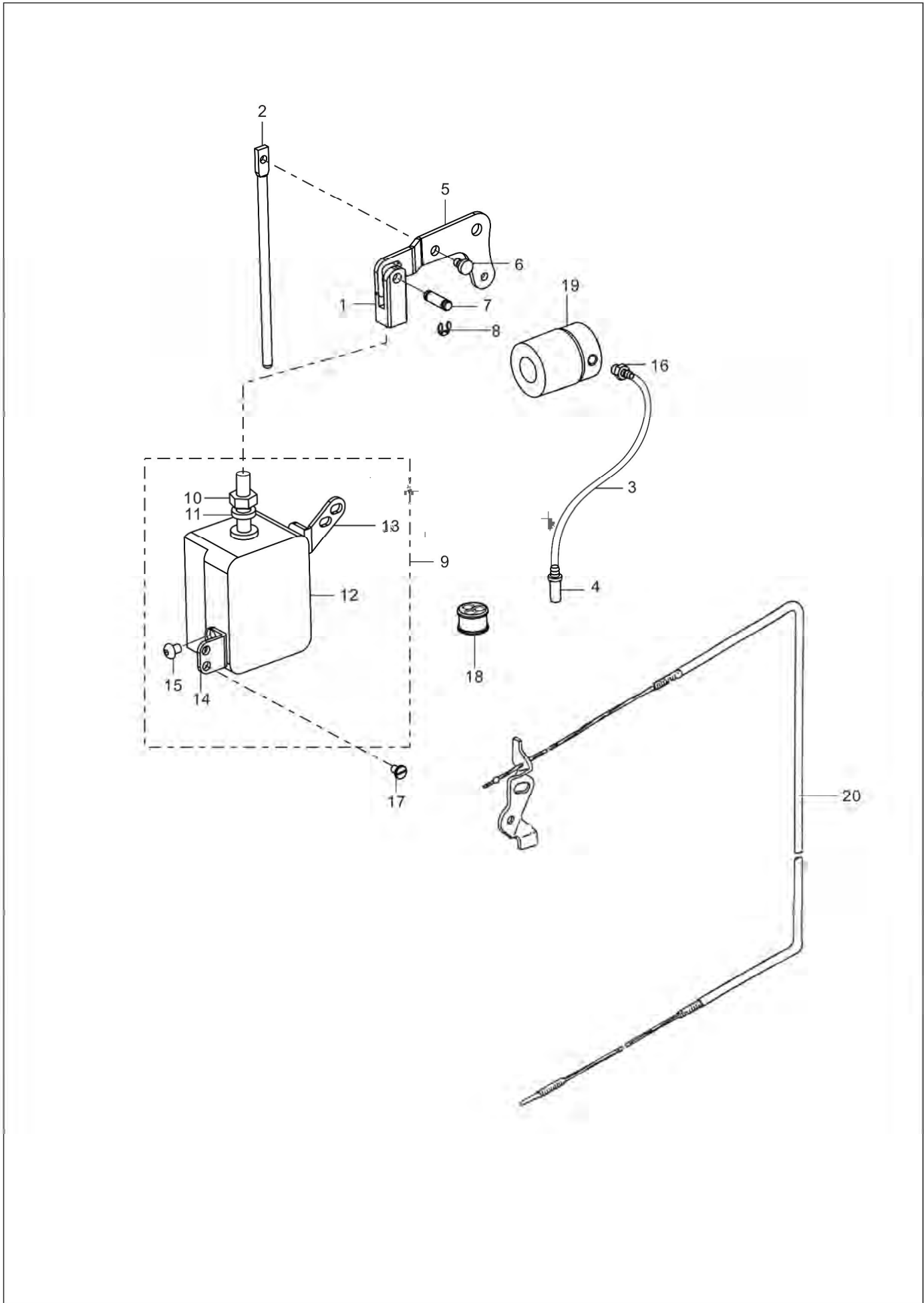

### 13.内置抬压脚部件 Built-in presser foot Components

序号 NO.	图号 REF NO.	名称	DESCRIPTION
1	SG1281-02-06	抬压脚电磁铁支柱	Presser foot solenoid pillar
2	SG1211-04-08	抬压脚顶杆	Connecting rod vertical
3	SG42-05003000-00A	供油管	Oil tube
4	SG1211-07-04	供油管接头(下)	Rubber joint(down)
5	SG1281-02-07	抬压脚后杠杆	Lifting lever ring
6	SG1211-04-07	抬压脚后杠杆螺钉	Lifting lever ring screw
7	SG1281-02-08	抬压脚电磁铁销子	Presser foot solenoid pin
8	SG24-05000000-08	开口挡圈	Snap ring
9	SG1281-02-02	抬压脚电磁铁大组件	Presser foot solenoid ASM.
10	SG14-60805010-01	抬压脚电磁铁锁紧螺母	Presser foot solenoid nut
11	SG1281-02-02-03	电磁铁缓冲垫	Magnetic plug cushion mat
12	SG1281-02-02-01	抬压脚电磁铁	Presser foot solenoid ASM.
13	SG1281-02-02-04	电磁铁右支架	Solenoid right bracket
14	SG1281-02-02-06	电磁铁左支架	Solenoid left bracket
15	SG12-40500825-01	抬压脚电磁铁支架固定螺钉	Presser foot solenoid bracket screw
16	SG423-12-36	供油管接头(上)	Rubber joint(upper)
17	SG11-30120920-02	抬压脚电磁铁固定螺钉	Presser foot solenoid screw
18	SG1281-02-03	三孔橡胶塞	Tripple-hole rubber stopper
19	SG1211-02-04	上轴中套	Main shaft bushing(middle)
20	SG1281-02-10	制动器组件	Arrester Asm.

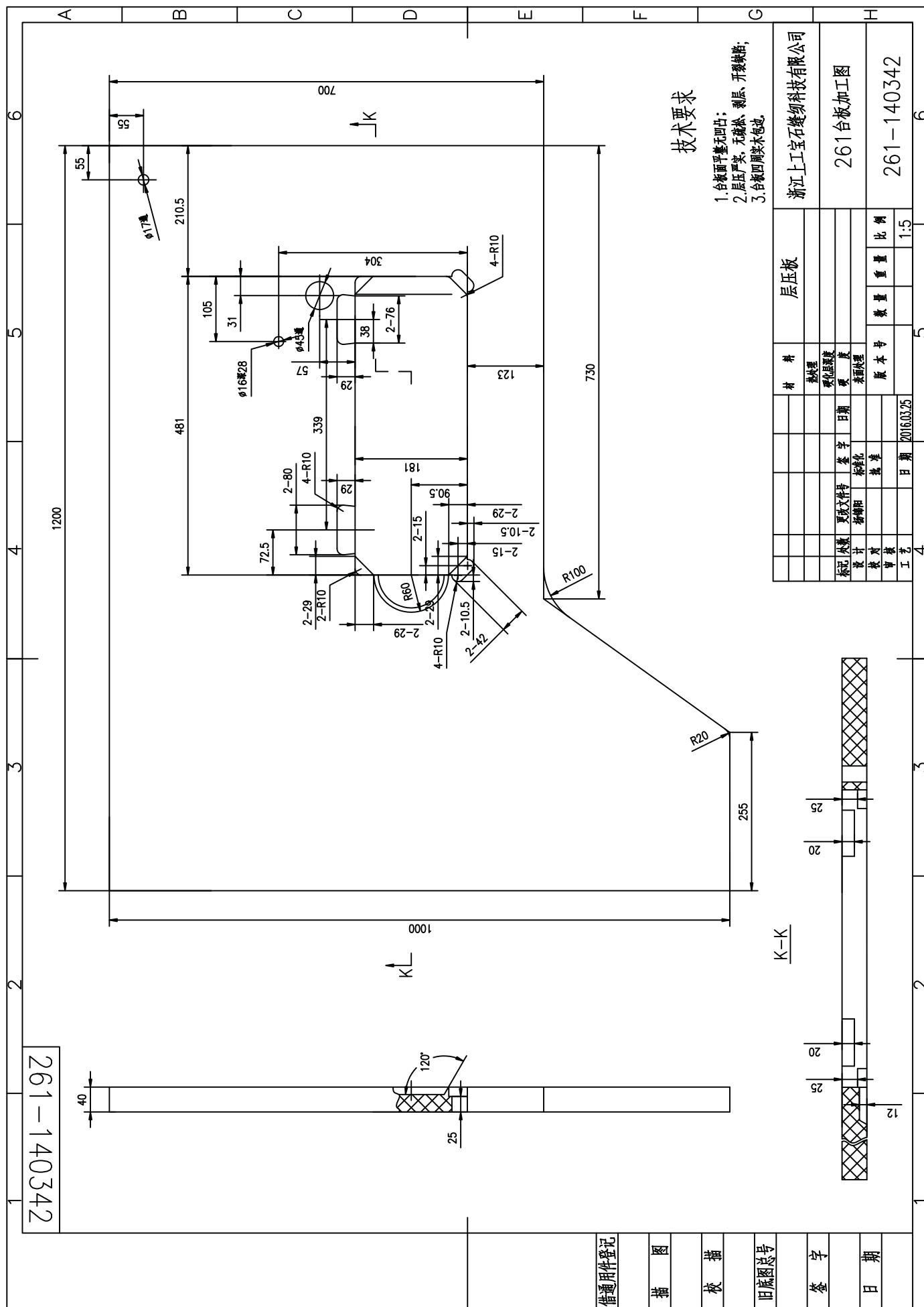

**技术要求**

1. 台面平整无凹出;
2. 层压严密, 无气泡、剥层、开裂缺陷;
3. 台板四周实木包边.

浙江上工宝石缝纫科技有限公司	
材料	层压板
热处理	
硬化层厚度	
胶层	
表面处理	
版本号	
数量	
重量	
比例	1:5
更新文件号	签字
日期	日期
2016.03.25	
设计	审核
日期	日期
2016.03.25	
工艺	

借通用件登记	
插图	
校核	
审核	
日期	

261-140342

K-K

K-L

K

Contact

Dürkopp Adler AG

PO Box 17 03 51, D-33719 Bielefeld

Potsdamer Straße 190, D-33719 Bielefeld

Phone: +49 (0) 521 9 25 00

Fax: +49 (0) 521 9 25 24 35

Manufacturer:

Shanggong Gemsy

No. 1 South Airport Road

Jiaojiang

Taizhou

Zhejiang Province

P. R. China



DÜRKOPP ADLER AG  
Potsdamer Str. 190  
33719 Bielefeld  
Germany  
Phone: +49 (0) 521 925 00  
Email: [service@duerkopp-adler.com](mailto:service@duerkopp-adler.com)  
[www.duerkopp-adler.com](http://www.duerkopp-adler.com)