

# CONSEW

## LIST OF PARTS

MODEL 825-ES EL

# PRICE LIST

From the library of: Diamond Needle Corp

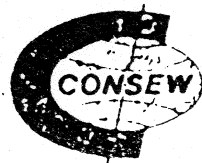

### CONSEW INTERNATIONAL LTD

Yamajin Bldg., 18, 1-chome, Hon-machi, Higashi-ku, Osaka 541, Japan  
P.O.Box: Osaka Higashi No. 509  
Telephone: Osaka 261-3291 ~ 3297 (7 Lines)  
Cable Address: "CONSEWMACH" Osaka  
Telex: J64459 CONSEW

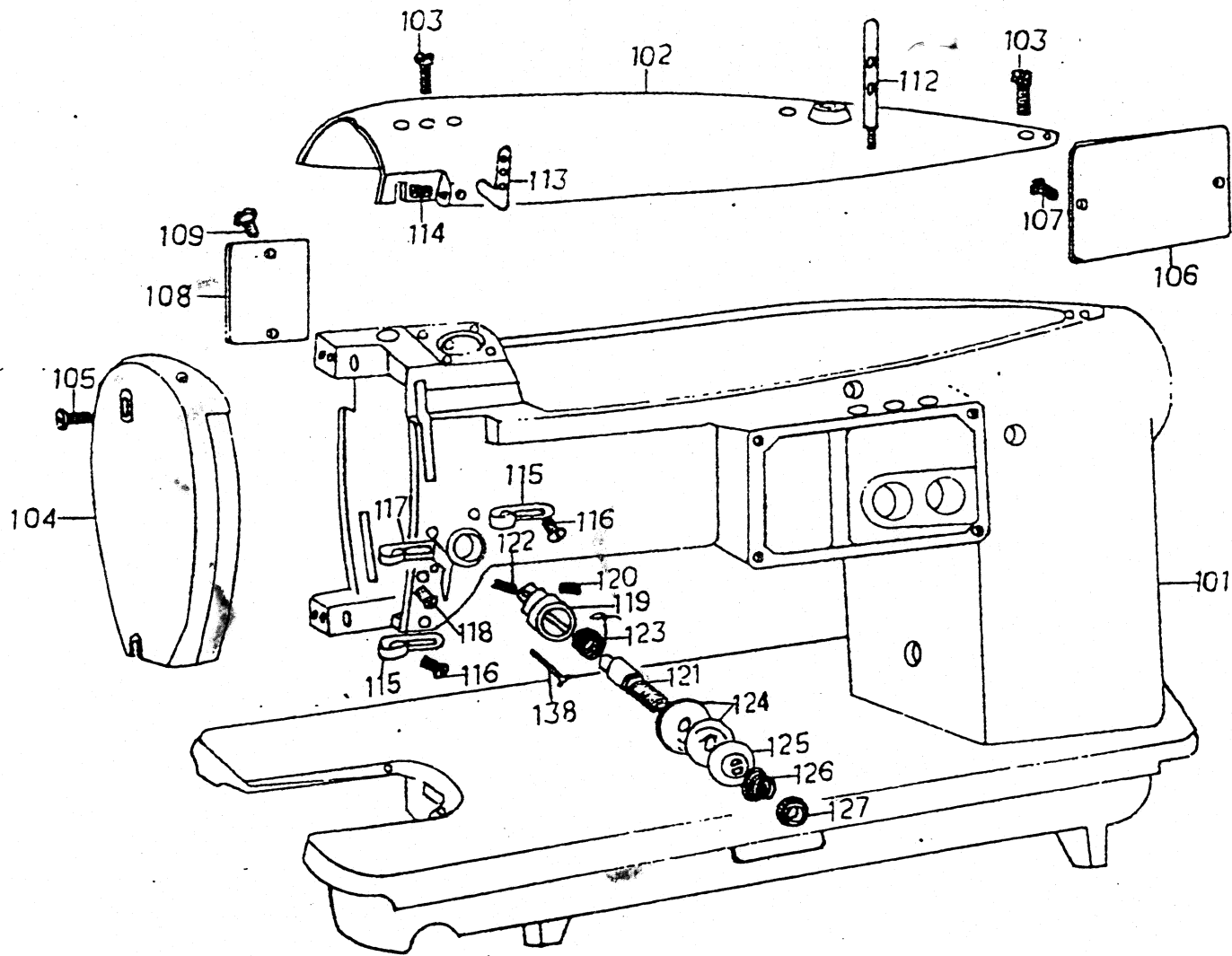

From the library of: Diamond Needle Corp

番号	品名	N A M E	使用個数	使用機
101	アームベッド(組)	Arm bed	1	Z
102	アーム上面カバー	Top cover	1	Z
103	アーム上面カバー締ネジ	... screw	2	Z
104	面板	Face plate	1	Z
105	面板締ネジ	... screw	2	Z
106	側板(大)	Arm side cover (Large)	1	Z
107	側板(大)締ネジ	... screw	2	Z
108	側板(小)	Arm side cover (Small)	1	Z
109	側板(小)締ネジ	... screw	2	Z
112	糸立棒	Needle thread guide pin (W 2 hole)	1	Z
113	三ッ目糸掛	Three hole thread eyelet	1	Z
114	三ッ目糸掛締ネジ	... screw	1	Z
115	アーム糸掛	Arm thread guide	2	Z
116	アーム糸掛止ネジ	... screw	2	Z
117	大糸掛	Tension post thread guide	1	Z
118	大糸掛止ネジ	... screw	1	Z
119	糸調子棒台	Tension post rocket	1	Z
120	糸調子棒台締ネジ	... screw	1	Z
121	糸調子棒	Tension post	1	Z
122	糸調子棒止ネジ	... screw	1	Z
123	糸取バネ	Take up spring	1	Z
124	糸調子皿	Tension disk	1	Z
125	糸調子皿押エ	Tension release washer	1	Z
126	糸調子バネ	Tension spring	1	Z
127	糸調子ナット	Tension nut	1	Z

From the library of: Diamond Needle Corp



番号	品名	N A M E	使用個数	使用部
201	針棒枠	Needle bar frame	1	Z
202	針棒押止ピン	... hinge pin	1	Z
203	針棒押止ピン止ネジ	... screw	1	Z
204	針棒	Needle bar	1	Z
205	針棒抱	Needle bar connecting stud	1	Z
206	針棒抱支エ	... bushing	1	Z
207	針棒抱支エ座	... washer	1	Z
208	針棒抱支エ座締ネジ	... screw	1	Z
209	針棒止ネジ	Needle bar set screw	1	Z
210	針棒クランクロット	Needle bar connecting link	1	Z
211	針棒クランク皿ネジ	... screw	1	Z
213	針棒押エ	... needle bar frame guide pin	1	Z
214	針棒押エ締ネジ	... screw	1	Z
215	ミシン針	Needle	1	Z
216	針止ネジ	Needle screw	1	Z
217	天ビン支エ軸	Take-up lever link hinge pin	1	Z
218	天ビン支エ軸止ネジ	... screw	1	Z
219	リンク天ビン	Take up lever	1	Z
220	針棒クランク	Needle bar crank	1	Z
221	針棒クランク止ネジ (大)	... screw (Large)	1	Z
222	針棒クランク止ネジ (小)	... screw (Small)	1	Z
223	天ビンクランク	Counter weight	1	Z
224	天ビンクランク止ネジ (大)	... screw (Large)	1	Z
225	天ビンクランク止ネジ (小)	... screw (Small)	1	Z
226	針棒クランクロット案内板	Needle bar connecting link guide plate	1	Z

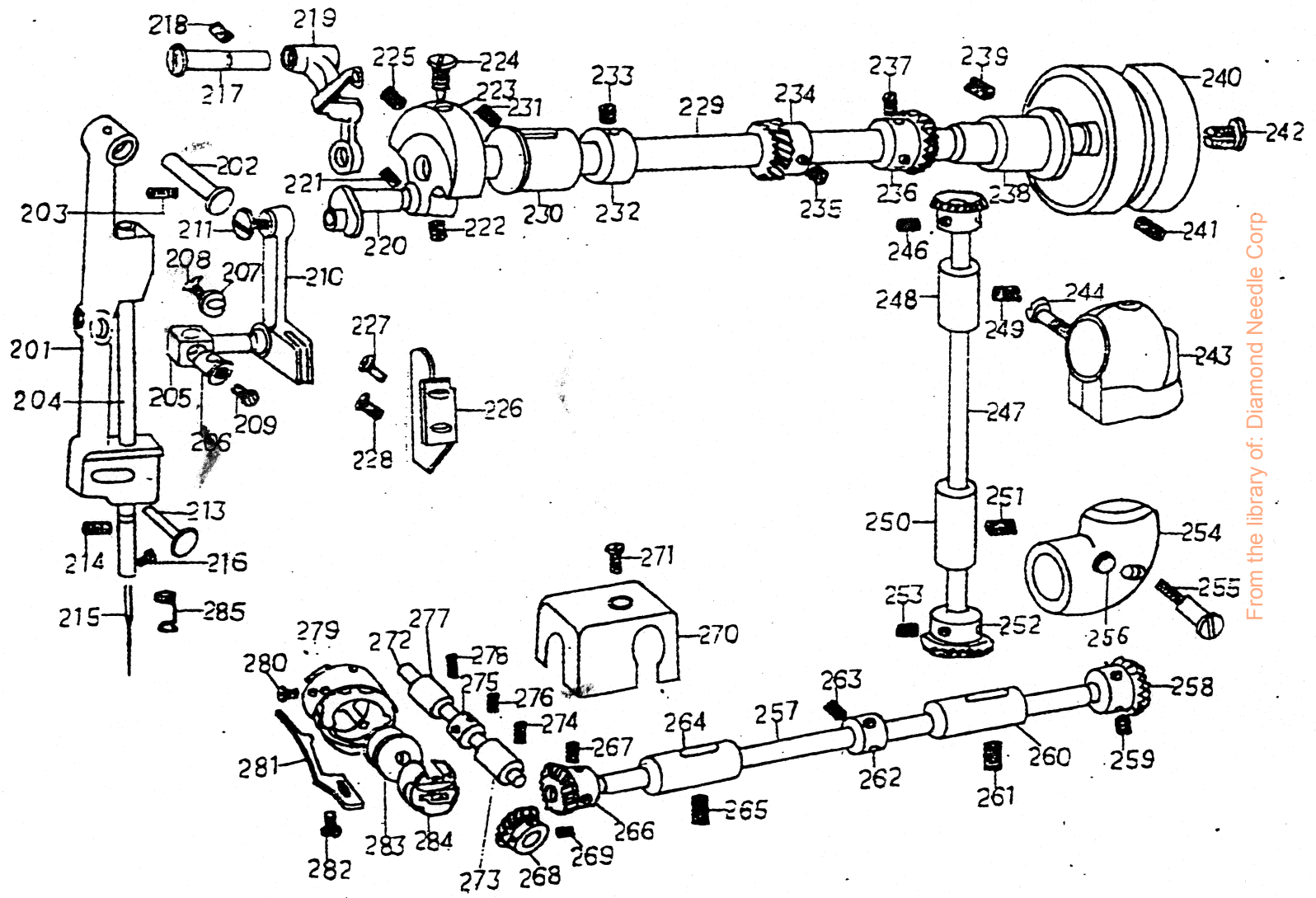

From the library of: Diamond Needle Corp

番号	品名	N A M E	使用個数	使用欄別
227	針棒クランクロット案内板止ネジ(上)	Needle bar connecting link guide plate screw (Upper)	1	Z
228	針棒クランクロット案内板止ネジ(下)	... screw (Lower)	1	Z
229	上軸	Arm shaft	1	Z
230	上軸メタル(左)	... bushing (Front)	1	Z
231	上軸メタル(左)止ネジ	... screw	1	Z
232	上軸カラー	... collar	1	Z
233	上軸カラー止ネジ	... screw	2	Z
234	針振動歯車	Needle vibration pinion (Spiral)	1	Z
235	針振動歯車止ネジ	... screw	2	Z
236	上軸歯車	Arm shaft (Horizontal) lever gear	1	Z
237	上軸歯車止ネジ	... screw	2	Z
238	上軸メタル(右)	Arm shaft bushing (Rear)	1	Z
239	上軸メタル(右)止ネジ	... screw	1	Z
240	ハズミ車	Hand wheel	1	Z
241	ハズミ車止ネジ	... screw	2	Z
242	ハズミ車締ネジ	... positioning screw	1	Z
243	上歯車ケース	Gear and pinion case	1	Z
244	上歯車ケース締ネジ	... screw	1	Z
245	立軸歯車(上)	Pinion	1	Z
246	立軸歯車(上)止ネジ	... screw	2	Z
247	立軸	Upright shaft	1	Z
248	立軸メタル(上)	... bushing (Upper)	1	Z
249	立軸メタル(上)止ネジ	... screw	1	Z
250	立軸メタル(下)	... bushing (Lower)	1	Z
251	立軸メタル(下)止ネジ	... screw	1	Z
252	立軸歯車(下)	... miter gear	1	Z

番号	品名	N A M E	使用個数	使用単位
253	立軸歯車(下)止ネジ	Upright shaft screw	2	Z
254	下歯車ケース	Miter gear case	1	Z
255	下歯車ケース締ネジ	... screw	1	Z
256	下歯車ケースツマミネジ	... oil plug screw	1	Z
257	下軸	Hook drive shaft	1	Z
258	下軸歯車(右)	... miter gear (Ring)	1	Z
259	下軸歯車(右)止ネジ	... screw	2	Z
260	下軸メタル(右)	... bushing (Right)	1	Z
261	下軸メタル(右)止ネジ	... screw	1	Z
262	下軸カラー	... thrust collar	1	Z
263	下軸カラー止ネジ	... screw	2	Z
264	下軸メタル(左)	... bushing (Left)	1	Z
265	下軸メタル(左)止ネジ	... screw	1	Z
266	下軸歯車(左)	... helical gear right	1	Z
267	下軸歯車(左)止ネジ	... screw	2	Z
268	釜軸歯車	Helical gear (Left)	1	Z
269	釜軸歯車止ネジ	... screw	2	Z
270	釜軸歯車ケース	Helical gear cover	1	Z
271	釜軸歯車ケース止ネジ	... screw	1	Z
272	釜軸	Hook shaft	1	Z
273	釜軸メタル(前)	... bushing (Front)	1	Z
274	釜軸メタル(前)止ネジ	... screw	1	Z
275	釜軸メタルカラー	... thrust collar	1	Z
276	釜軸メタルカラー止ネジ	... screw	2	Z
277	釜軸メタル(後)	... bushing (Rear)	1	Z
278	釜軸メタル(後)止ネジ	... screw	1	Z

From the library of: Diamond Needle Corp





番号	品名	N A M E	使用個数	使用機種
337	針振調節器	Zig-zag regulator	1	Z
338	針振軸締ネジ	... screw	1	Z
339	針振調節器玉	... slide block	1	Z
340	針振調節器玉ピン	... stud	1	Z
341	玉ピン締ナット	... nut	1	Z
344	針振クランクメタル	Zig-zag regulator bushing	1	Z
345	針振クランクメタル止ネジ	... screw	1	Z
346	針振クランク軸	Zig-zag regulator	1	Z
348	巾出調節ツマミ止ネジ	... screw	2	Z
349	針振ダイヤル座金	... washer	1	Z
350	巾出調節ツマミ締ネジ	... end screw	1	Z
352	針振目盛板止ネジ	... screw	4	Z
353	針振ストッパー	... stoper	2	Z
354	針振ストッパーワッシャー	... washer	2	Z
355	針振ストッパー止ナット	... nut	2	Z

From the library of: Diamond Needle Corp

番 号	品 名	N A M E	使用個数	使用欄
373	巾出調節つまみ	Dial	1	Z
374	針振指針	Needle vibrator stop index finger	1	Z
	巾出調節			
	針振			
377	針振指針止ネジ	... screw	1	Z
378	引上板	Lifting lever link	1	Z
379	引上板止ネジ	... screw	1	Z
380	押エ棒ツリ	Presser bar lifting and releasing lever bracket	1	Z
381	糸ユルメレバー	Tension releasing lever	1	Z
382	糸ユルメレバー止ネジ	... screw	1	Z
383	押エ上	Presser bar lifter	1	Z
384	押エ金	Presser foot	1	Z
385	押エ金締ネジ	... screw	1	Z
386	押エバネ	... spring	1	Z
387	押エ棒	Presser bar	1	Z
388	針振目盛板	Zig-zag indicator plate	1	Z

From the library of: Diamond Needle Corp

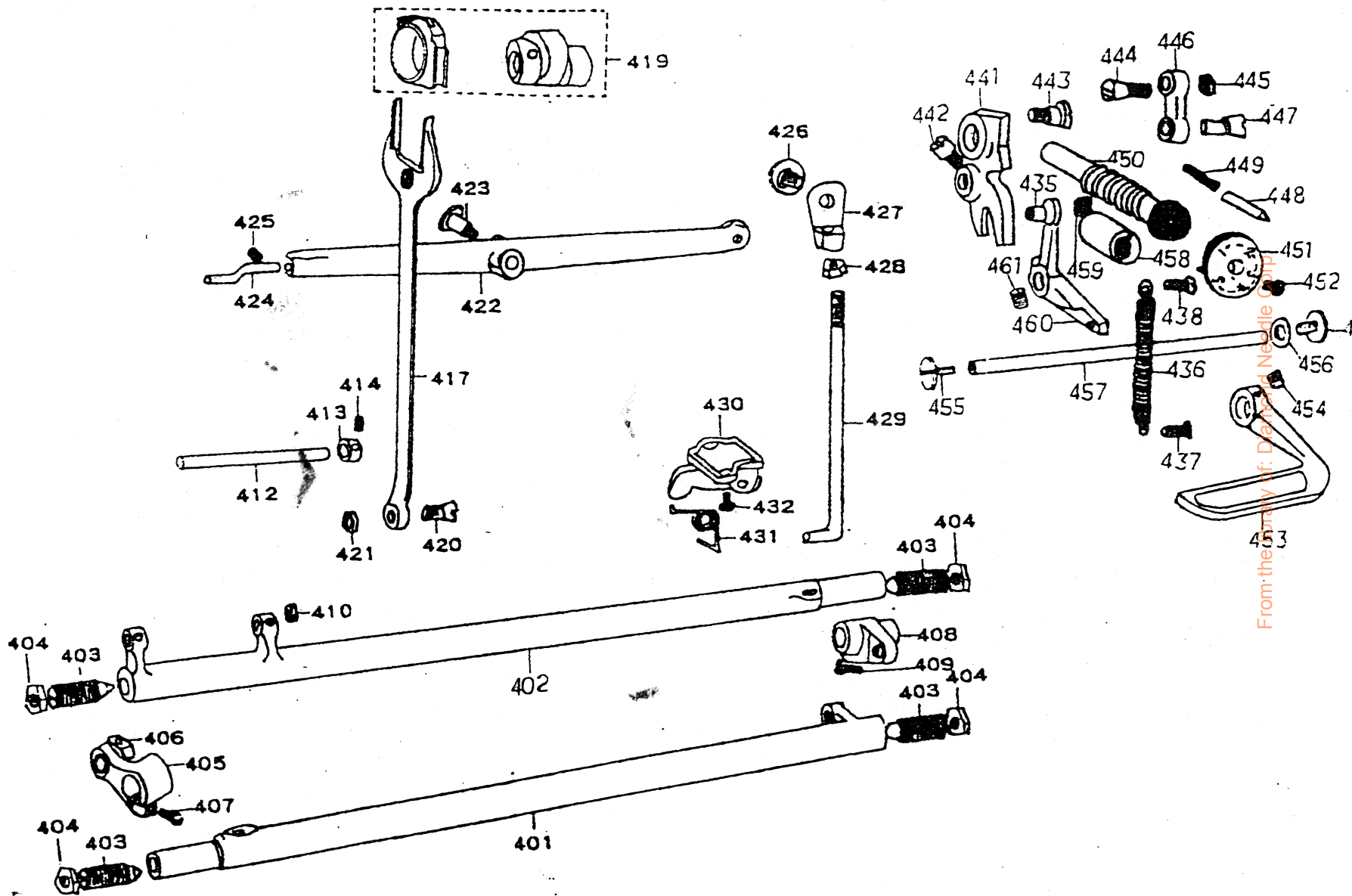

From the original: Dental Needle

番号	品名	N A M E	使用個数	使用機
401	上下送り軸	Feed lifting rock shaft	1	Z
402	水平送り軸	Feed rock shaft	1	Z
403	送り軸ネジセンター	... screw center	4	Z
404	送り軸ネジセンターナット	... screw center nut	4	Z
405	上下送り腕	Feed lifting rock shaft crank	1	Z
406	上下送りコロ	Feed lifting rock shaft roller	1	Z
407	上下送り腕締ネジ	Feed lifting rock shaft crank clamping screw	1	Z
408	水平送り腕	Feed rock shaft crank	1	Z
409	水平送り腕締ネジ	Feed rock shaft crank clamping screw	1	Z
410	送り台軸止ネジ	Feed bar shaft set screw	2	Z
411	送り台	Feed bar	1	Z
412	送り台軸	Feed bar shaft	1	Z
413	送り台軸カラー	Feed bar shaft collar	1	Z
414	送り台軸カラー止ネジ	... screw	1	Z
417	二又ロット	Feed forked connection	1	Z
419	送りカム (組)	Feed cam	1	Z
420	テーパーネジ	Feed lifting rock shaft connecting rod hinge screw	2	Z
421	テーパーネジナット	... hinge screw nut	2	Z
422	ヒザ上げテコ	Knee lifter lifting lever	1	Z
423	ヒザ上げテコ締ネジ	... screw	1	Z
424	ヒザ上げテコピン	Knee lifter lifting lever pin	1	Z
425	ヒザ上げテコピン止ネジ	... screw	1	Z
426	テコ接手ヒンジネジ	Knee lifter lifting lever connecting rod joint hinge screw	1	Z

From the library of: Diamond Needle Corp.

番 号	品 名	N A M E	使用個数	使用機種
427	テコ接手	Knee lifter lifting lever connecting rod joint	1	Z
428	ヒザ上げ引棒ナット	Knee lifter lifting lever connecting rod lock nut	1	Z
429	ヒザ上げ引棒	Knee lifter lifting lever connecting rod	1	Z
430	ヒザ上げ台	Knee lifter bell crank	1	Z
431	ヒザ上げバネ	... spring	1	Z
432	ヒザ上げ台締ネジ	... screw	2	Z
435	送り調節レバーコロ	... roller	1	Z
436	送り調節レバー引バネ	... spring	1	Z
437	送り調節レバー引バネ止ネジ(下)	... screw (Lower)	1	Z
438	送り調節レバー引バネ止ネジ(上)	... screw (Upper)	1	Z
441	又付送り調節器	Feed regulator (Forked)	1	Z
442	送りリンク止ネジ	... screw	1	Z
443	送り調節器止ネジ	... screw	1	Z
444	送りリンクテーパーネジ	Feed connecting lower hinge screw	1	Z
445	送りリンクテーパーネジ締ナット	... screw nut	1	Z
446	送りリンク	Feed connecting link	1	Z
447	送りリンク軸	Feed connecting link hinge stud	1	Z
448	目盛位置決メピン	Feed regulating stud lock pin	1	Z
449	目盛位置決メピンバネ	... spring	1	Z
450	送り調節ネジ	Feed regulating stud	1	Z
451	送り目盛板	Feed regulating stud head	1	Z
452	送り目盛板締ネジ	... screw	1	Z

From the library of: Diamond Needle Corp



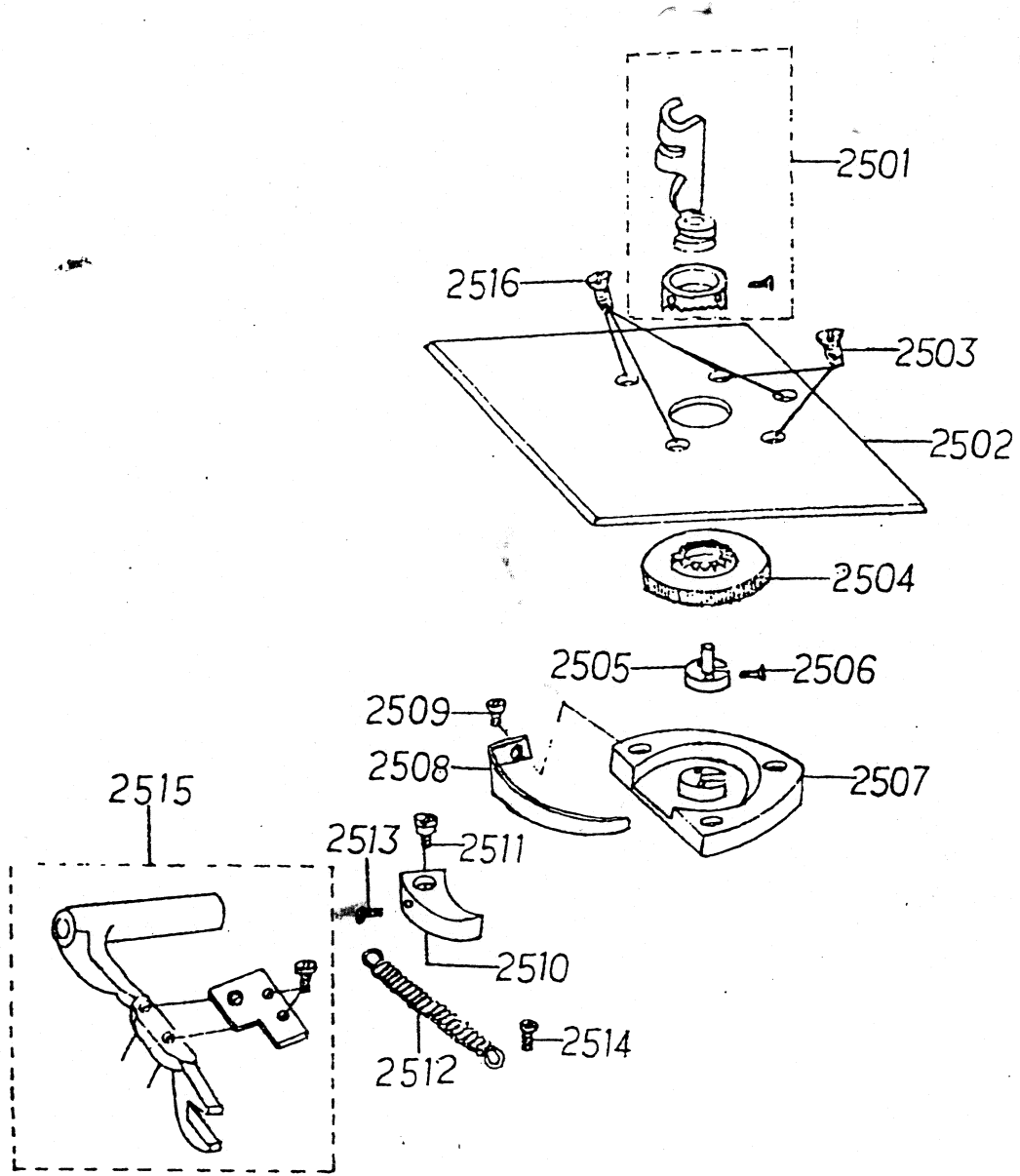



PART NO. (PART NAME) Q'TY COST PART NAME

番号	品名	使用個数	摘要	
2501	押エ金	1組SET	10000	PRESSER FOOT
2502	角板	1PCE.	7500	PLATE
2503	角板締ネジ	2	80	... SCREW
2504	丸穴送りギヤー	1	12000	GEAR
2505	丸穴針板	1	1700	NEEDLE PLATE
2506	丸穴針板締ネジ	2	150	... SCREW
2507	送りクラッチ台	1	9000	FEED CLUTCH BASE
2508	逆転止板バネ	1	350	SPRING
2509	逆転止板バネ止ネジ	1	60	... SCREW
2510	ギヤー送り爪	1	1500	FEED NAIL
2511	ギヤー送り爪段ネジ	1	500	... SCREW
2512	ギヤー送り爪引バネ	1	250	... SPRING
2513	ギヤー送り爪引バネ止ネジ(爪)	1	90	... SPRING SCREW
2514	ギヤー送り爪引バネ止ネジ(ベット)	1	90	... SPRING SCREW
2515	丸穴送り土台	1組SET	4500	FEED BASE SET
2516	送りクラッチ台締ネジ	3	80	SCREW
	クラッチセット	1組SET	28000	CLUTCH SET

From the library of: Diamond Needle Corp