



HIGHLEAD

HLK-1006

Single-Needle Lockstitch, Electronic Bar Tack Machine

**INDUSTRIAL SEWING
MECHANICAL PARTS CATALOG**

SHANGHAI HUIGONG NO.3 SEWING MACHINE FACTORY

A. ARM BED AND ITS ACCESSORIES (1)

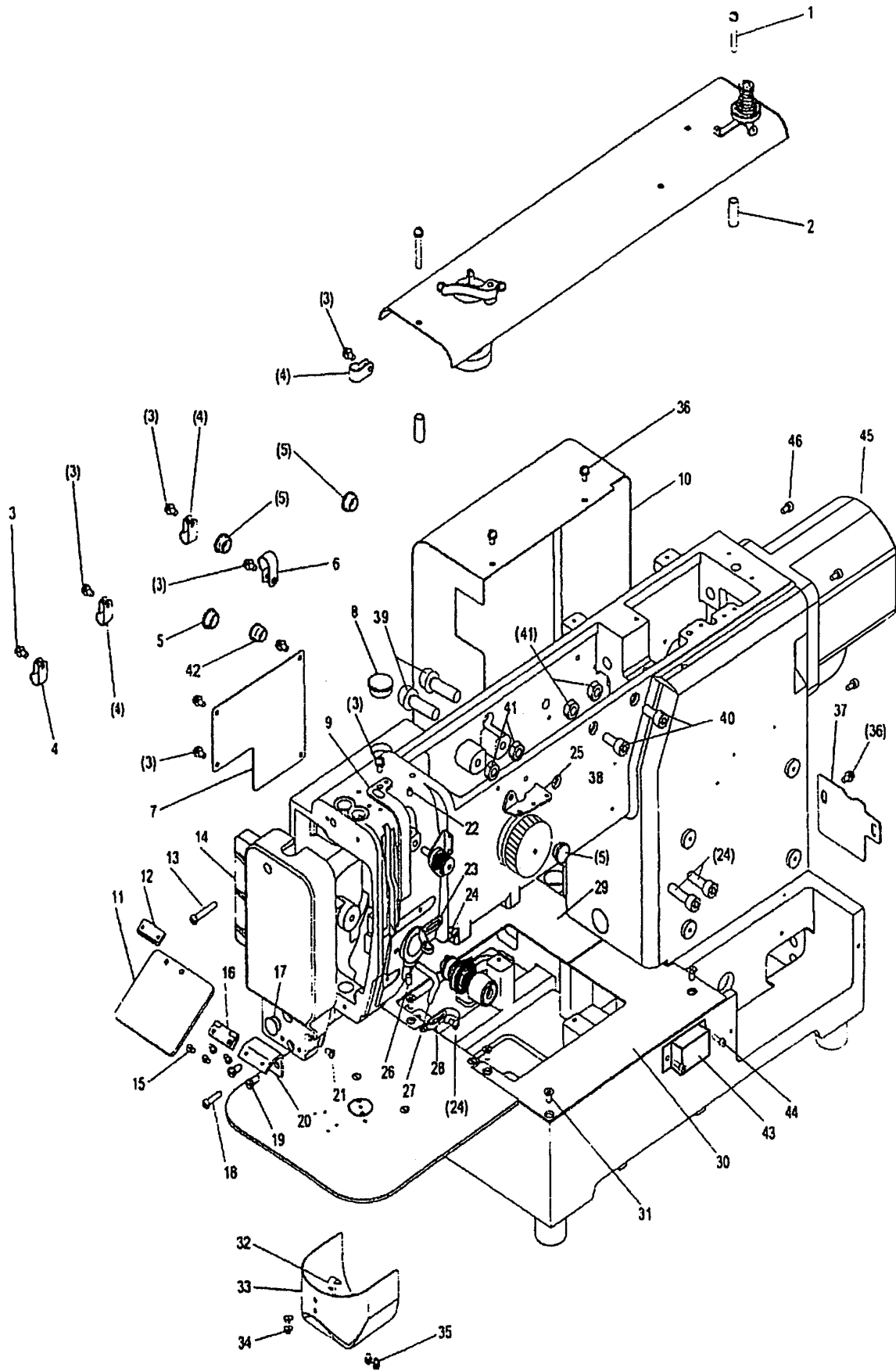

From the library of: Diamond Needle Corp

A. ARM BED AND ITS ACCESSORIES (1)

Fig. No.	Part No.	Description	Pcs.	Remarks
A01	HZ11040300	Screw M4 × 30	2	M4 × 30
A02	H6623B8001	Spacer	2	
A03	HZ11040080	Screw M4 × 8	10	M4 × 8
A04	H6650H8001	Nylon clip AB-5N	4	AB-5N
A05	H4715B8001	Rubber plug Φ13	4	Φ13
A06	H6648I8001	Nylon clip AB-6N	1	AB-6N
A07	H6611B8001	Cover	1	
A08	HA307B0673	Rubber plug Φ19	2	Φ19
A09	H6689B8001	Thread take-up lever guard	1	
A10	HF15401008	Motor cover	1	
A11	HM014B8001	Eye guard	1	
A12	H6675B8001	Adapter	1	
A13	HZ11040250	Screw M4 × 25	1	M4 × 25 发黑
A14	HM019B8001	Face cover	1	
A15	HA104G0654	Screw 1/8(44) × 6	4	1/8(44) × 6
A16	H6696B8001	Hinge	1	
A17	HA307B0674	Rubber plug Φ11.8	1	Φ11.8
A18	HZ11040200	Screw M4 × 20	1	M4 × 20
A19	HA100C2190	Screw 11/64(40) × 8	2	11/64(40) × 8
A20	HM015B8001	Eye guard bracket	1	
A21	HA106B0676	Screw 9/64(40) × 6	1	9/64(40) × 6
A22	H431040060	Screw M4 × 6	1	M4 × 6
A23	HA600B2050	Thread guide	1	
A24	HZ11040060	Screw M4 × 6	3	M4 × 6
A25	HA700B2050	Thread guide	1	
A26	H431050080	Screw M5 × 8	1	M5 × 8
A27	H3000B2130	Thread guide	1	
A28	HA106B0675	Thread guide	1	
A29	HF15401007	X Cover plate (L)	1	
A30	HF15401006	X Cover plate (R)	1	
A31	HZ11040080	Screw M4 × 8	6	M4 × 8
A32	H6691B8001	Latch	1	
A33	H6693B8001	Cylinder cover	1	
A34	H6692B8001	Screw 9/64(40) × 3.2	2	9/64(40) × 3.2
A35	HZ11030060	Screw M3 × 6	2	M3 × 6
A36	HZ11040080	Screw M4 × 8	6	M4 × 8
A37	HF15401009	Cover	1	
A38	H415050200	Screw M5 × 20	2	M5 × 20
A39	H415050250	Screw M5 × 25	2	M5 × 25
A40	H415050120	Screw M5 × 12	2	M5 × 12
A41	H003002050	Nut M5	6	M5
A42	HA300B2090	Rubber plug Φ8.8	1	Φ8.8
A43	HF15401019	Cover	1	

A. ARM BED AND ITS ACCESSORIES (1)

Fig. No.	Part No.	Description	Pcs.	Remarks
A44	HZ11040060	Screw M4 × 6	2	M4 × 6
A45	HF15401026	Motor cover	1	
A46	H415050200	Screw M5 × 20	4	

B. ARM BED AND ITS ACCESSORIES (2)

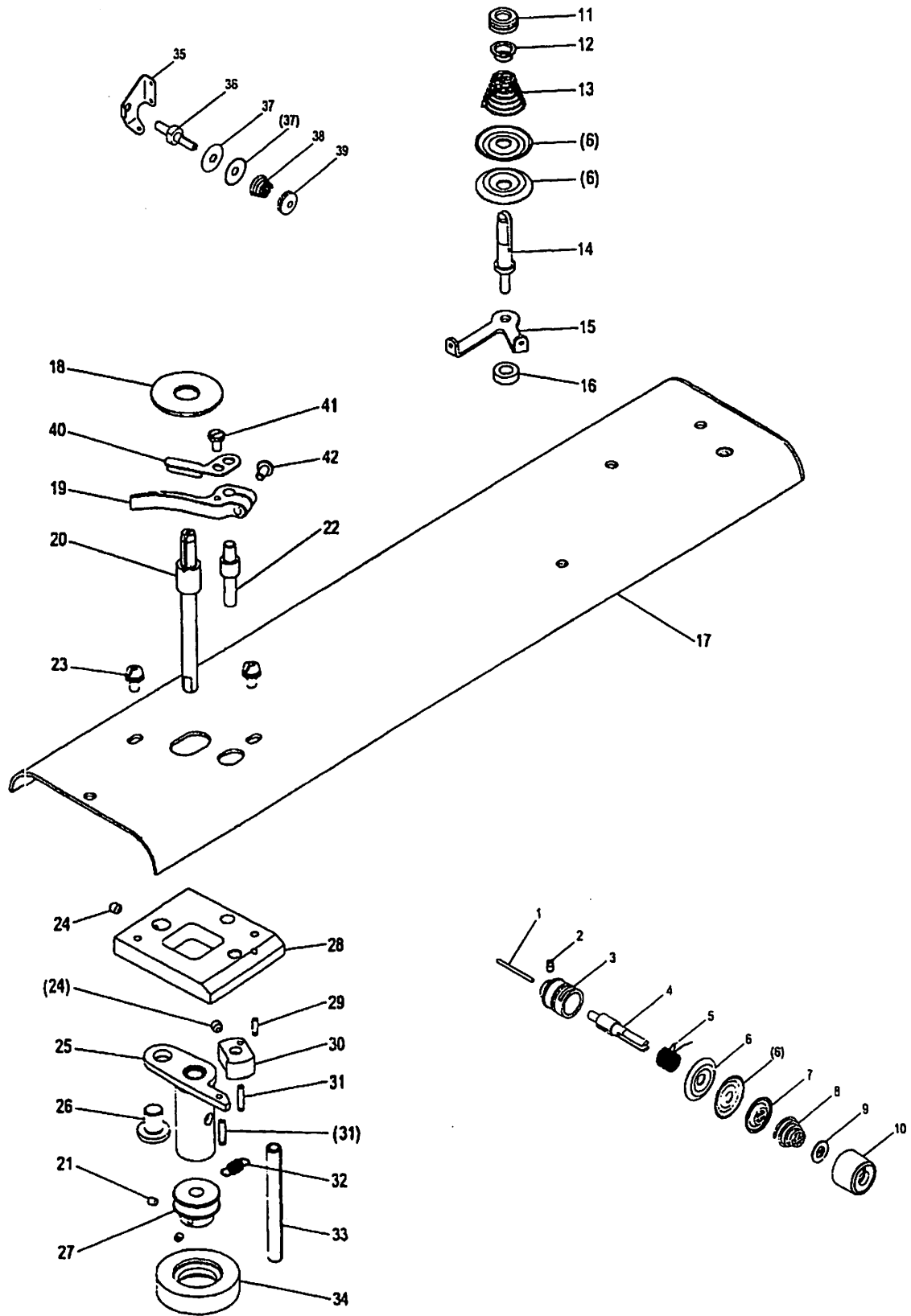

From the library of: Diamond Needle Corp

B.ARM BED AND IT'S ACCESSORIES (2)

Fig. No.	Part No.	Description	Pcs.	Remarks
B01	HA115B0709	Pin	1	
B02	HA115B0708	Screw 9/64(40) × 4	1	
B03	HA310B0703	Regulator casing	1	
B04	HA115B0701	Thread tension stud	1	
B05	HA115B0706	Thread take-up spring	1	
B06	HA115B0705	Thread tension discs	4	
B07	HA310B0702	Disc retaining plate	1	
B08	H6675C8001	Thread tension spring	1	
B09	HA115B7010	Thumb nut revolution stopper	1	
B10	HA310B0701	Thumb nut	1	
B11	H660GB8001	Thumb nut	1	
B12	H660FB8001	Spring guide	1	
B13	H660EB8001	Thread tension spring	1	
B14	H660HB8001	Thread tension stud	1	
B15	H6662B8001	Thread guide	1	
B16	H6663B8001	Spacer	1	
B17	HM012B8001	Top cover	1	
B18	H6656B8001	Spacer	1	
B19	H6651B8001	Lever	1	
B20	H6648B8001	Driven shaft	1	
B21	H431030040	Screw M3 × 4	2	M3 × 4
B22	H6649B8001	Shaft	1	
B23	HZ11040100	Screw M4 × 10	2	M4 × 10
B24	H431040040	Screw M4 × 4	2	M4 × 4
B25	H6645B7101	Lever	1	
B26	H6650B8001	Pin	1	
B27	H6657B8001	Wheel	1	
B28	H6644B8001	Bracket	1	
B29	H6659B8001	Pin $\Phi 2.5 \times 8$	1	$\Phi 2.5 \times 8$
B30	H6652B8001	Cam	1	
B31	H6660B8001	Pin $\Phi 2.5 \times 12$	2	$\Phi 2.5 \times 12$
B32	H6653B8001	Spring	1	
B33	H6655B8001	Pin $\Phi 6 \times 56$	1	$\Phi 6 \times 56$
B34	H6658B8001	Tire	1	
B35	HA710B0674	Thread guide	1	
B36	HA710B0673	Thread tension stud	1	
B37	HA112B0693	Thread tension discs	2	
B38	HA710B0672	Thread tension spring	1	
B39	HA710B0671	Thumb nut	1	
B40	H662EB8001	Adjuster plate	1	
B41	H662DB8001	Screw 9/64(40) × 6.5	1	9/64(40) × 6.5
B42	H3100B2100	Screw 9/64(40) × 11	1	9/64(40) × 11

C. SEWING MECHANISM (1)

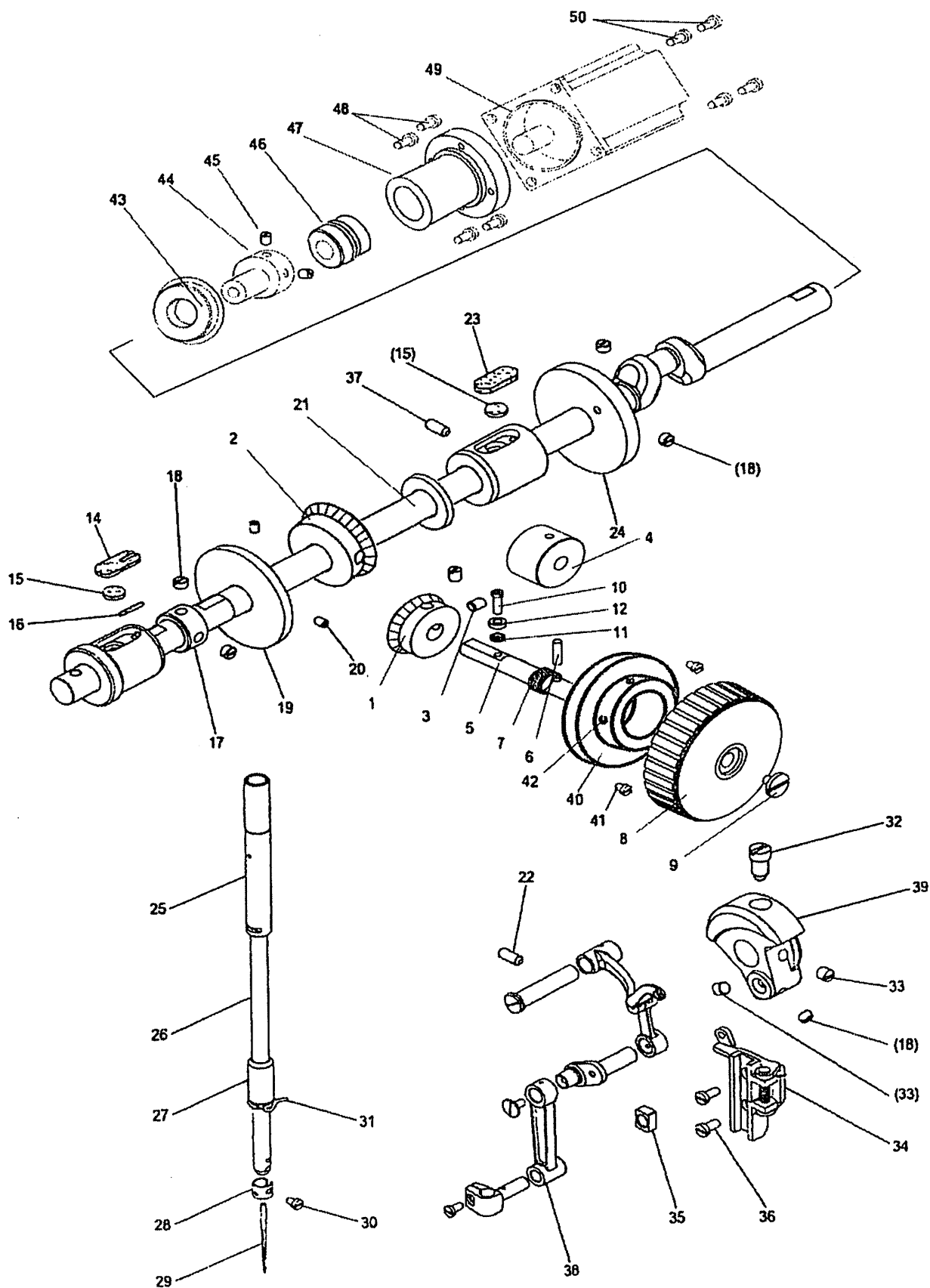

From the library of: Diamond Needle Corp

C. SEWING MECHANISM (1)

Fig. No.	Part No.	Description	Pcs.	Remarks
C01	HF113D2122	Bevel gear for hand wheel shaft	1	
C02	HF113D2112	Bevel gear for arm shaft	1	
C03	HA108C0663	Set screw	4	
C04	HF15401016	Hand wheel bushing	1	
C05	HF15401015	Hand wheel shaft	1	
C06	H609025120	Pin	1	
C07	H4767E8001	Spring	1	
C08	HB42E52081	Hand wheel	1	
C09	H5311F8001	Screw	1	
C10	HF15401013	Screw	1	
C11	HF15401012	Washer	1	
C12	HF15401014	Bearing	1	
C14	H2009B0743	Felt	1	
C15	H6616B8001	Felt	2	
C16	H2009B0742	Felt	1	
C17	HA108G0661	Collar	1	
C18	HA105D0662	Screw 1/4(40) × 4	5	1/4(40) × 4
C19	HF15402008	Pulley	1	
C20	H431040060	Screw M4 × 6	2	M4 × 6
C21	HM004C8001	Drive shaft	1	
C22	HS90101012	Screw M5 × 12	1	M5 × 12
C23	H2009B0731	Felt	1	
C24	H6606F8001	Thread trimmer cam	1	
C25	H6612B8001	Neddle bar bushing(upper)	1	
C26	H6624C8001	Neddle bar	1	
C27	H6613B8001	Neddle bar bushing(lower)	1	
C28	H6625C8001	Thread guide	1	
C29	HM010C8001	Neddle DP × 17#18	1	DP × 17#18
C30	HA100C2170	Screw 1/8(44) × 4.5	1	1/8(44) × 4.5
C31	HA300C2070	Thread guide	1	
C32	HA100C2070	Set screw 9/32(28)	1	9/32(28)
C33	HA307C0662	Screw 1/4(40) × 6	2	1/4(40) × 6
C34	HM005C7101	Guide assy	1	
C35	HA100C2200	Square block	1	
C36	H6623C8001	Screw M4 × 8	2	M4 × 8
C37	H901310010	Screw M5 × 10	1	M5 × 10
C38	H6611C7101	Thread take-up lever assy	1	
C39	H6607C8001	Crank	1	
C40	HF15401001	Set plate	1	
C41	H3210F0681	Screw M5 × 6	2	M5 × 6
C42	H415050120	Screw M5 × 12	3	M5 × 12
C43	H3205J0662	Bearing	1	6204Z ZNR
C44	HF15402001	Bushing	1	

C. SEWING MECHANISM (1)

Fig. No.	Part No.	Description	Pcs.	Remarks
C45	H431040060	Screw	2	
C46	HB2152C072	Clutch assy	1	
C47	HF15402002	Motor base	1	
C48	H415050200	Screw M5 × 20	4	
C49	HF15402003	Sevor motor	1	
C50	H415050200	Screw M5 × 16	4	

D. SEWING MECHANISM (2)

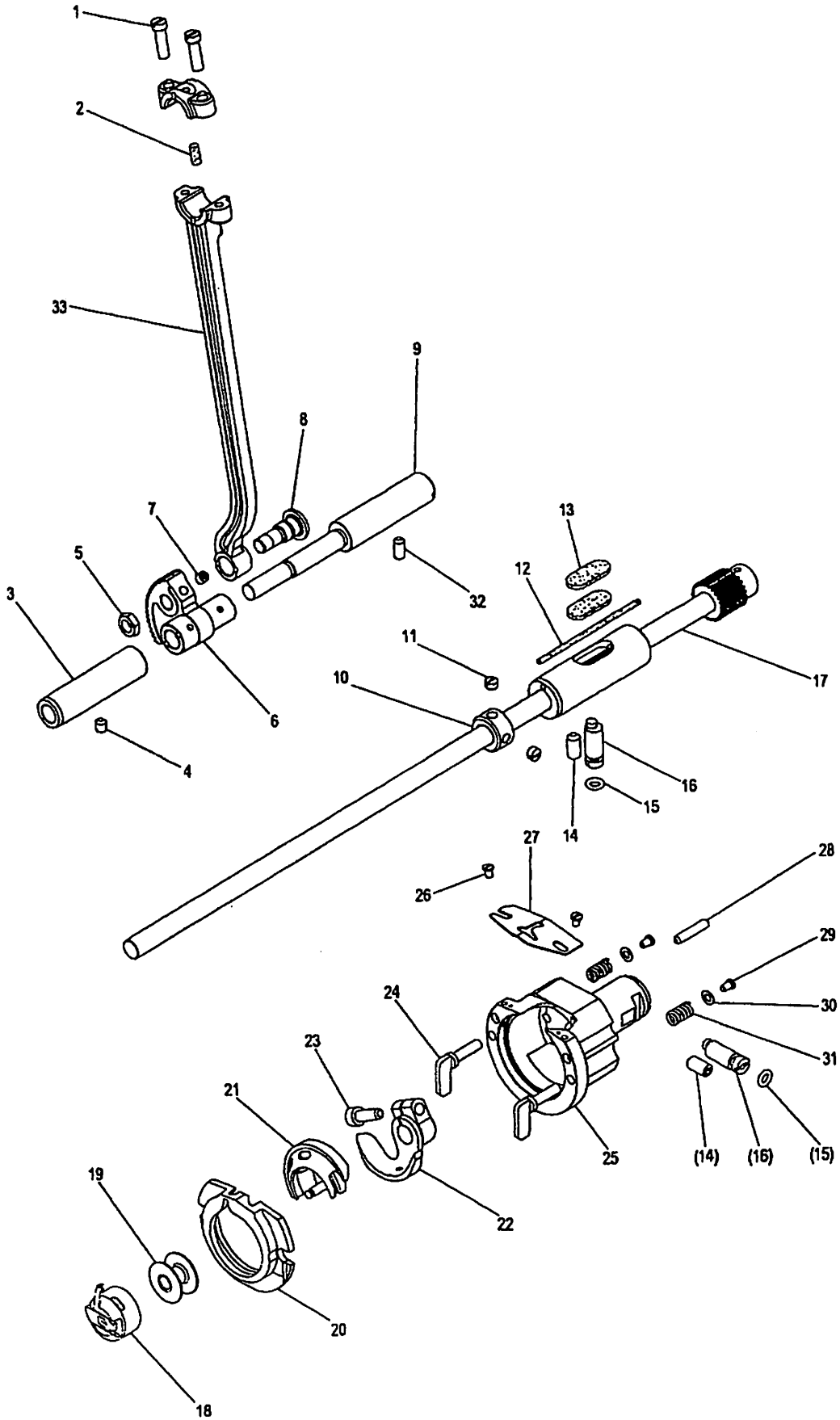

D. SEWING MECHANISM (2)

Fig. No.	Part No.	Description	Pcs.	Remarks
D01	HA304G0656	Screw 3/16(28) × 15	2	3/16(28) × 15
D02	H6634C8001	Felt	1	
D03	H6628B8001	Bushing	1	
D04	HS90101006	Screw M5 × 6	1	M5 × 6
D05	H2010J0066	Nut 9/32(28)	1	9/32(28)
D06	H6631C8001	Sector gear	1	
D07	H431050050	Screw M5 × 5	1	M5 × 5
D08	H6630C8001	Screw 9/32(28)	1	9/32(28)
D09	H6635C8001	Rock shaft	1	
D10	H6670C8001	Collar	1	
D11	HA305E0662	Screw 15/64(28) × 4.5	2	15/64(28) × 4.5
D12	H6627B8001	Oil braid	1	
D13	H2009B0743	Felt	2	
D14	HS90131112	Screw M6 × 12	2	M6 × 12
D15	HA115B7011	O-ring	2	
D16	H6648C8001	Eccentric shaft	2	
D17	H6637C7101	Hook shaft assy	1	
D18	H6684C8001	Bobbin case	1	SC181
D19	H6685C8001	Bobbin	1	
D20	H6674C8001	Hook retaine	1	
D21	H6683C8001	Inner hook	1	SH181
D22	H6654C8001	Hook driver	1	
D23	HS90321016	Bolt M5 × 16	1	M5 × 16
D24	H6646C8001	Hook clamp	2	
D25	H6642C8001	Outer hook	1	
D26	H6658C8001	Screw 1/8(40) × 4	2	1/8(40) × 4
D27	H6657C8001	Thread guide	1	
D28	H6651C8001	Pin M6-4 × 18	1	
D29	H6643C8001	Screw 1/8(44) × 4.5	2	1/8(44) × 4.5
D30	H6644C8001	Washer	2	
D31	H6645C8001	Spring	2	
D32	HS90101012	Screw M5 × 12	1	M5 × 12
D33	H6628C7101	Connecting rod assy	1	

E. X-Y MECHANISM (1)

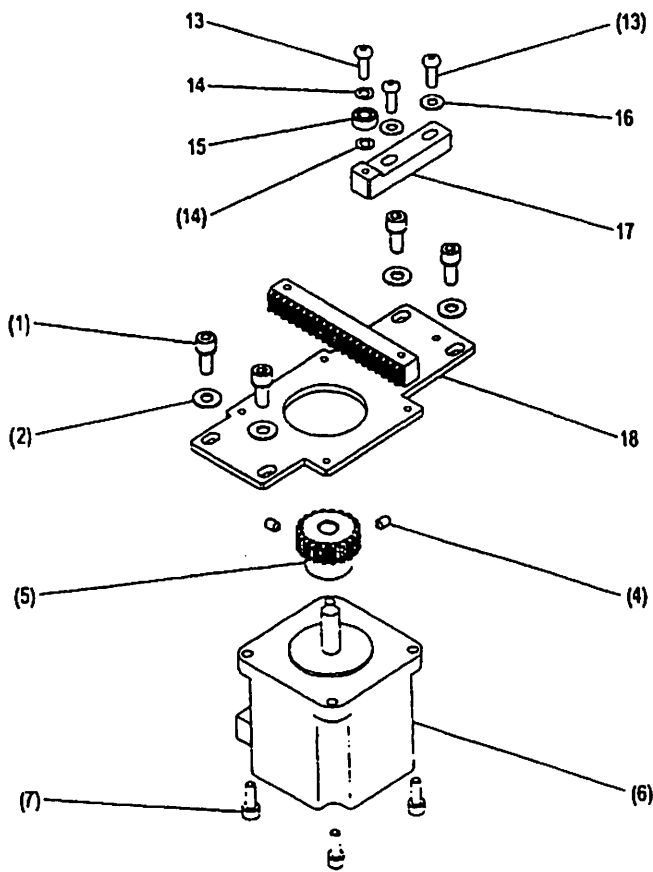
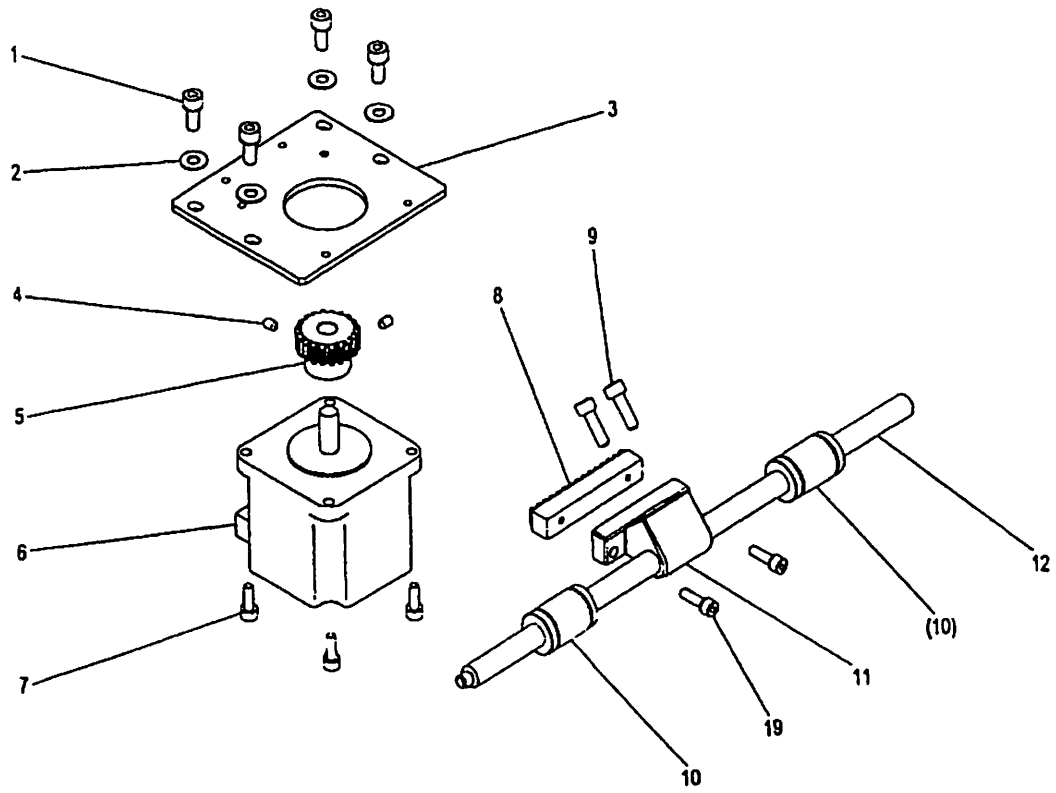

E. X-Y MECHANISM (1)

Fig. No.	Part No.	Description	Pcs.	Remarks
E01	H415050120	Bolt M5×12	8	M5×12
E02	H6686D8001	Washer 5	8	M5
E03	H6646D8001	Motor mounting plate Y	1	
E04	H431040060	Screw M4×6	4	M4×6
E05	H6631D8001	Pinion gear	2	
E06	HF15403010	Stepping motor	2	
E07	H415040120	Bolt M4×12	8	M4×12
E08	HF15403011	Rack Y	1	
E09	H415050160	Bolt M5×16	2	M5×16
E10	H6623B8001	Ball bushing 10	2	M10
E11	H6649D8001	Rack adapter Y	1	
E12	HM010D8001	Linear shaft Y	1	
E13	H416040120	Bolt M4×12	3	M4×12
E14	H6684D8001	Washer 4	2	M4
E15	H6636D8001	Ball bearing	1	
E16	H6685D8001	Washer 4	2	M4
E17	H6635D8001	Bearing supporter	1	
E18	H6634D8001	Motor mounting palte X	1	
E19	H6693D8001	Bolt M4×14	2	M4×14

F. X-Y MECHANISM (2)

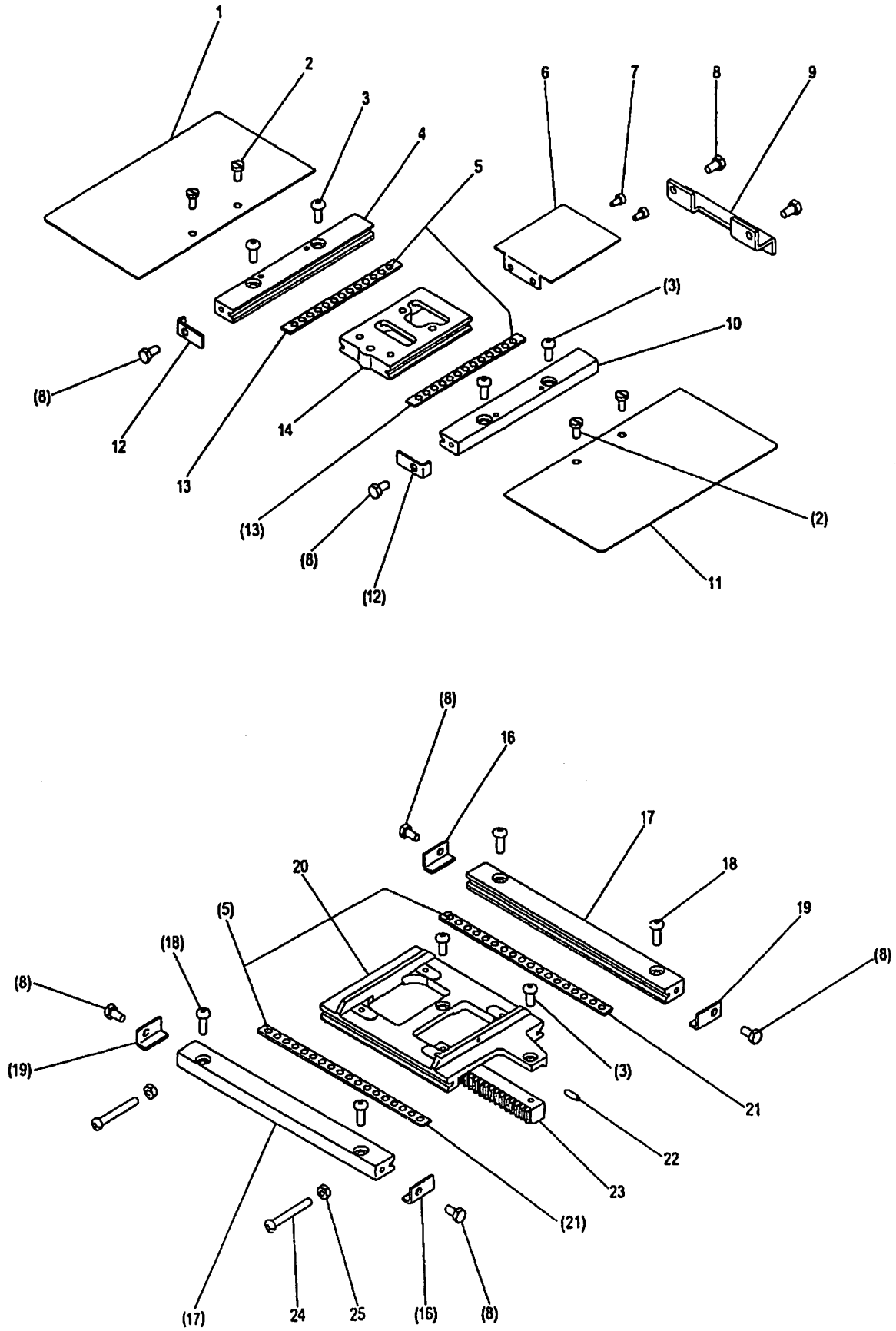

F. X-Y MECHANISM (2)

Fig. No.	Part No.	Description	Pcs.	Remarks
F01	HF15401009	Cover L	1	
F02	HA70264C06	Screw 9/64(40) × 8	4	9/64(40) × 8
F03	H416040100	Bolt M4 × 10	6	M4 × 10
F04	HF15403006	Fixed race Y(L)	1	
F05	H6618D8001	Steel ball 5/32	62	5/32
F06	H6623D8001	Cover plate Y	1	
F07	H415030060	Bolt M3 × 6	2	M3 × 6
F08	H103040080	Bolt M4 × 8	8	M4 × 8
F09	HF15403007	Rear stopper Y	1	
F10	HF15403005	Fixed race Y(R)	1	
F11	HF15401009	Cover R	1	
F12	H6617D8001	Front stopper Y	2	
F13	HF15403004	Retainer Y	2	
F14	H6619D8001	Movable race Y	1	
F16	H6611D8001	Stopper X	2	
F17	HF15403002	Fixed race X	2	
F18	H416040120	Bolt M4 × 12	4	M4 × 12
F19	H6610D8001	Stopper X	2	
F20	H6606D8001	Movable race X	1	
F21	HF15403001	Retainer X	2	
F22	H431030100	Screw M3 × 10	1	M3 × 10
F23	HF15403008	Rack X	1	
F24	HZ11040300	Screw M4 × 30	2	M4 × 30
F25	H003001040	Nut M4	2	M4

H. PRESSER FOOT MECHANISM

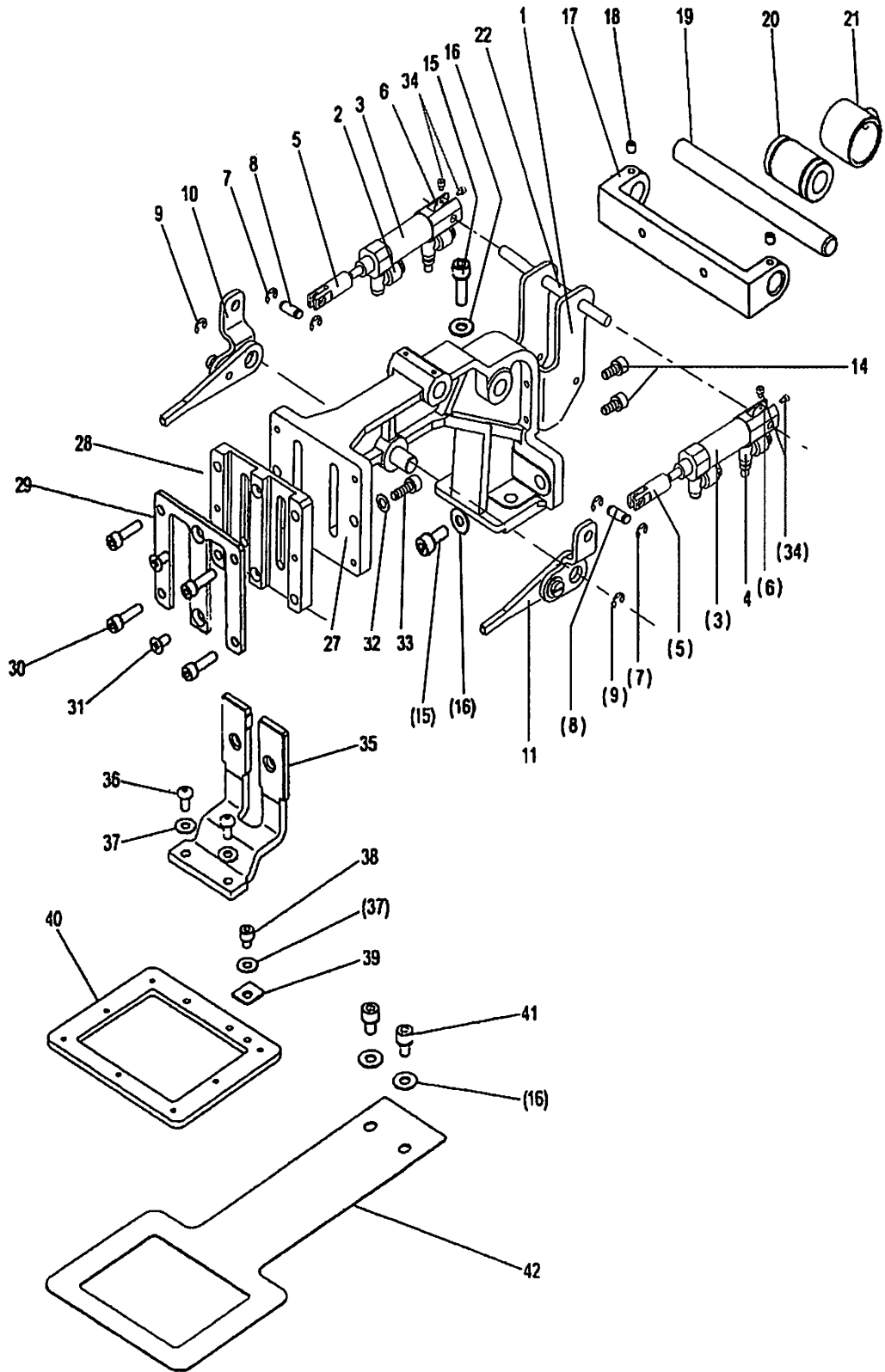

From the library of: Diamond Needle Corp

H. PRESSER FOOT MECHANISM

Fig. No.	Part No.	Description	Pcs.	Remarks
H01	HF15404017	Cylinder bracket	1	
H02	HEE4218001	Cylinder joint	2	
H03	HEE4108001	Cylinder	2	CJ2D16D-T1247-15 (SMC)
H04	HF937E8001	Cylinder joint	2	ESL4-M5
H05	HF15404014	Link pin	2	
H06	HF15404015	Collar	2	
H07	H007013040	E-type retaining ring 4	4	
H08	HEE4708001	Pin	2	
H09	H007013060	E-type retaining ring 6	2	
H10	HEE4127101	Lever assy 2	1	
H11	HEE4087101	Lever assy 1	1	
H14	H415040080	Bolt M4×8	4	M4×8
H15	H415050140	Bolt M5×14	4	M5×14
H16	H6686D8001	Washer 5	6	M5
H17	HF15404002	Bracket	1	
H18	H431040050	Screw M4×5	2	M4×5
H19	HF15404004	Shaft	1	
H20	H6623B8001	Ball bushing 10	1	Φ10
H21	H6682E8001	Bearing housing	1	
H22	HF15404016	Pin	1	
H27	HM012E8001	Work holder arm	1	
H28	HM011E8001	Work holder guide	1	
H29	HM008E8001	Cover	1	
H30	H415040160	Bolt M4×16	4	M4×16
H31	H660JB8001	Screw M4×8	2	M4×8
H32	H6684D8001	Washer 4	2	M4
H33	H415040120	Bolt M4×12	2	M4×12
H34	HF997J8001	Boit M3×5	4	
H35	HF15404006	Clamp foot	1	
H36	H416040080	Bolt M4×8	2	M4×8
H37	H6685D8001	Washer 4	3	M4
H38	H415040050	Bolt M4×5	1	M4×5
H39	H666GE8001	Clamp stopper	1	
H40	HF15404001	Clamp frame	1	
H41	H415050080	Bolt M5×8	2	M5×8
H42	HF15404005	Feed plate	1	

J. THREAD TRIMMING MECHANISM

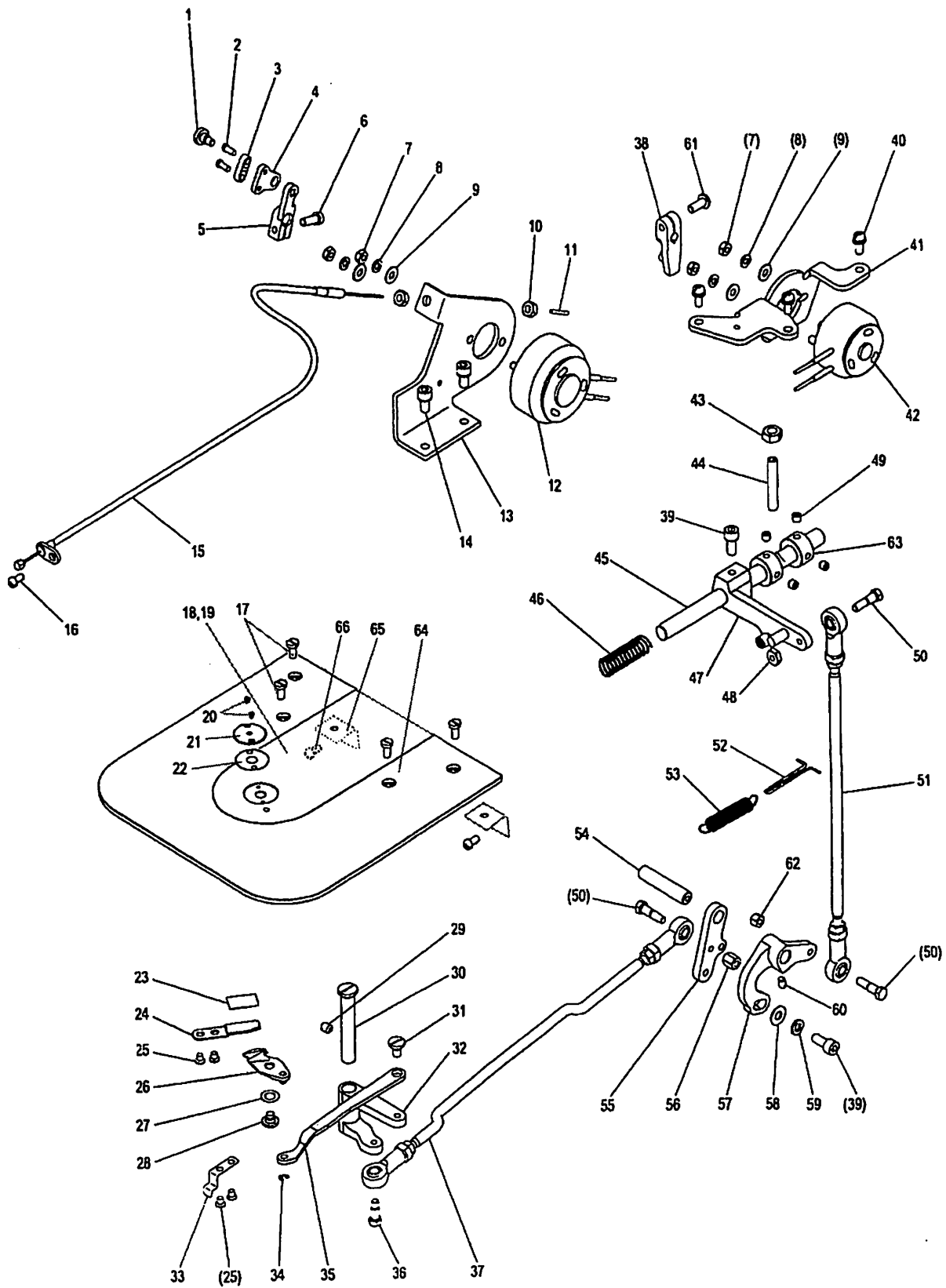

J. THREAD TRIMMING MECHANISM

Fig. No.	Part No.	Description	Pcs.	Remarks
J01	HM038E8001	Screw 11/64 (40)	1	11/64 (40)
J02	HA712N6912	Screw 1/8 (44) × 7	2	1/8 (44) × 7
J03	HA712N6911	Holder	1	
J04	HM010G8001	Bracket	1	
J05	HM011G8001	Crank	1	
J06	HA111G0683	Screw 11/64 (40) × 12	1	
J07	H6683D8001	Nut M4	4	M4
J08	H6613F8001	Spring washer 4	4	M4
J09	H6685D8001	Washer 4	4	M4
J10	H668DE8001	Nut M5	2	M5
J11	HM020G8001	Pipe	1	
J12	HM012G7101	Solenoid(thread release)	1	
J13	HM009G8001	Solenoid bracket	1	
J14	H415050100	Bolt M5 × 10	2	M5 × 10
J15	HM016G7101	Flexible wire assy	1	
J16	HZ11040080	Screw M4 × 8	1	M4 × 8
J17	H6623C8001	Screw M4 × 8	4	M4 × 8
J18	HM007G8001	Slide plate	1	
J19	H6686J8001	Film sheet	1	
J20	H6675F8001	Screw 3/32 (56) × 2.8	2	3/32 (56) × 2.8
J21	H6676F8001	Needle plate	1	
J22	H6677F8001	Spacer	1	
J23	H6695F8001	Spacer	1	
J24	H6673F8001	Fixed knife	1	
J25	H6692B8001	Screw 9/64 (40) × 3.2	4	9/64 (40) × 3.2
J26	H6671F8001	Movable knife	1	
J27	H6679F8001	Wave washer 6	1	M6
J28	H6678F8001	Screw 11/64 (40)	1	11/64 (40)
J29	H661CB8001	Screw M5 × 8	1	M5 × 8
J30	H6664F8001	Stepped pin	1	
J31	H6666F8001	Screw 3/16 (28)	1	3/16 (28)
J32	H6658F8001	Knife driving crank (3)	1	
J33	H6680F8001	Leaf spring	1	
J34	H007013025	E-type retaining ring 2.5	1	
J35	H6667F8001	Link	1	
J36	H6659F8001	Bolt 11/64 (40)	1	11/64 (40)
J37	H6662F8001	Connecting rod(horizontal)	1	
J38	H6611F8001	Crank	1	
J39	H415050120	Bolt M5 × 12	2	M5 × 12
J40	HZ11040100	Screw M4 × 10	3	M4 × 10
J41	H6609F8001	Solenoid bracket	1	
J42	H6615F7101	Solenoid (thread trim)	1	
J43	H003001060	Nut M6	1	M6

J. THREAD TRIMMING MECHANISM

Fig. No.	Part No.	Description	Pcs.	Remarks
J44	H431060350	Screw M6 × 35	1	M6 × 35
J45	H6622F8001	Shaft	1	
J46	H6623F8001	Spring	1	
J47	H6635F7101	Cam follower assy	1	
J48	H6641F8001	Nut 11/64(40)	1	11/64(40)
J49	H431050050	Screw M5 × 5	4	M5 × 5
J50	H6644F8001	Bolt 11/64(40)	3	11/64(40)
J51	H6634F8001	Connecting rod (vertical)	1	
J52	H6646F8001	Hook	1	
J53	H6645F8001	Spring	1	
J54	H6654F8001	Shaft	1	
J55	H6653F8001	Knife driving crank(2)	1	
J56	H6643F8001	Long nut 11/64(40)	1	11/64(40)
J57	H6651F8001	Knife driving crank(1)	1	
J58	HA300J2230	Washer 5	1	M5
J59	H6694F8001	Spring washer 5	1	M5
J60	HA100B2110	Screw 11/64(40) × 5.5	1	11/64(40) × 5.5
J61	H416050120	Bolt M5 × 12	1	M5 × 12
J62	H6642F8001	Nut 11/64(40)	1	11/64(40)
J63	H6625F8001	Collor	1	
J64	HF15406003	Slide plate	1	
J65	HF15406004	Bracket	4	
J66	H6623C8001	Screw M4 × 8	4	M4 × 8

K. CENTER PRESSER FOOT MECHANISM

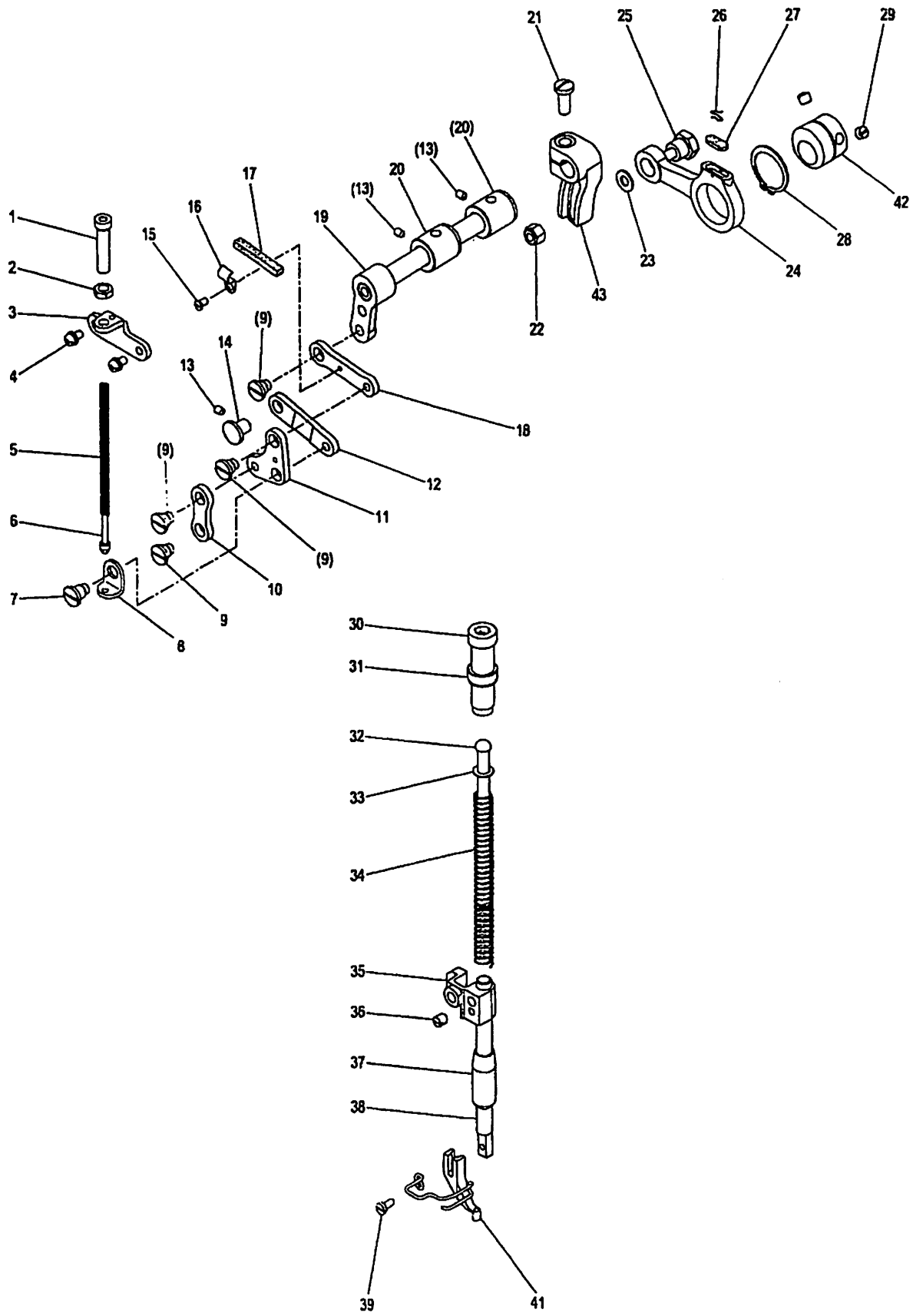

From the library of: Diamond Needle Corp

K. CENTER PRESSER FOOT MECHANISM

Fig. No.	Part No.	Description	Pcs.	Remarks
K01	H2010J0065	Thumb screw 9/32(28) × 35	1	9/32(28) × 35
K02	H2010J0066	Nut 9/32(28)	1	9/32(28)
K03	HMO18F8001	Bracket	1	
K04	H6642B8001	Screw M4 × 8	2	M4 × 8
K05	HMO22F8001	Spring	1	
K06	H2000J2040	Spring guide bar	1	
K07	HMO16F8002	Screw 1/4(40)	1	1/4(40)
K08	HMO15F8001	Supporter	1	
K09	HMO16F8001	Screw 1/4(40)	4	1/4(40)
K10	HMO14F8001	Link	1	
K11	HMO11F8001	Ball crank	1	
K12	HMO13F8001	Link	1	
K13	H431040100	Screw M4 × 10	3	M4 × 10
K14	H660FB8001	Pin	1	
K15	HA106B7101	Screw 9/64(40) × 6	1	9/64(40) × 6
K16	H3200K0190	Holder	1	
K17	H2000M0080	Felt	1	
K18	HMO12F8001	Link	1	
K19	HMO07F7101	Arm-shaft assy	1	
K20	HMO06B8001	Bushing	2	
K21	H2012N0652	Screw 1/4(40) × 16	1	1/4(40) × 16
K22	HS91165206	U-nut 6 × 0.75	1	6 × 0.75
K23	H2013J0065	Washer 6	1	M6
K24	HMO05F8001	Crank rod	1	
K25	H2000J2100	Bolt M6	1	M6
K26	H20111C106	Holder	1	
K27	H2014J0068	Felt	1	
K28	H007009250	C-type retaining ring 25	1	
K29	HA307C0662	Screw 1/4(40) × 6	2	1/4(40) × 6
K30	HA309H0681	Thumb screw 1/2(28) × 43	1	1/2(28) × 43
K31	HA107H0692	Nut 1/2(28)	1	1/2(28)
K32	HMO25F8001	Presser bar guide	1	
K33	H6654B8001	Washer 6	1	M6
K34	HMO26F8001	Spring	1	
K35	H6027H8001	Presser bar holder	1	
K36	HA3411D308	Screw 12/64(28) × 6	1	12/64(28) × 6
K37	HA100H2090	Bushing	1	
K38	HMO29F8001	Presser bar	1	
K39	H2000I2050	Screw 9/64(40) × 8	1	9/64(40) × 8
K41	HMO27F8001	Presser foot Φ3	1	
K42	H2014J0652	Crank	1	
K43	H2100I2010	Arm	1	

L. CENTER PRESSER FOOT LIFT MECHANISM

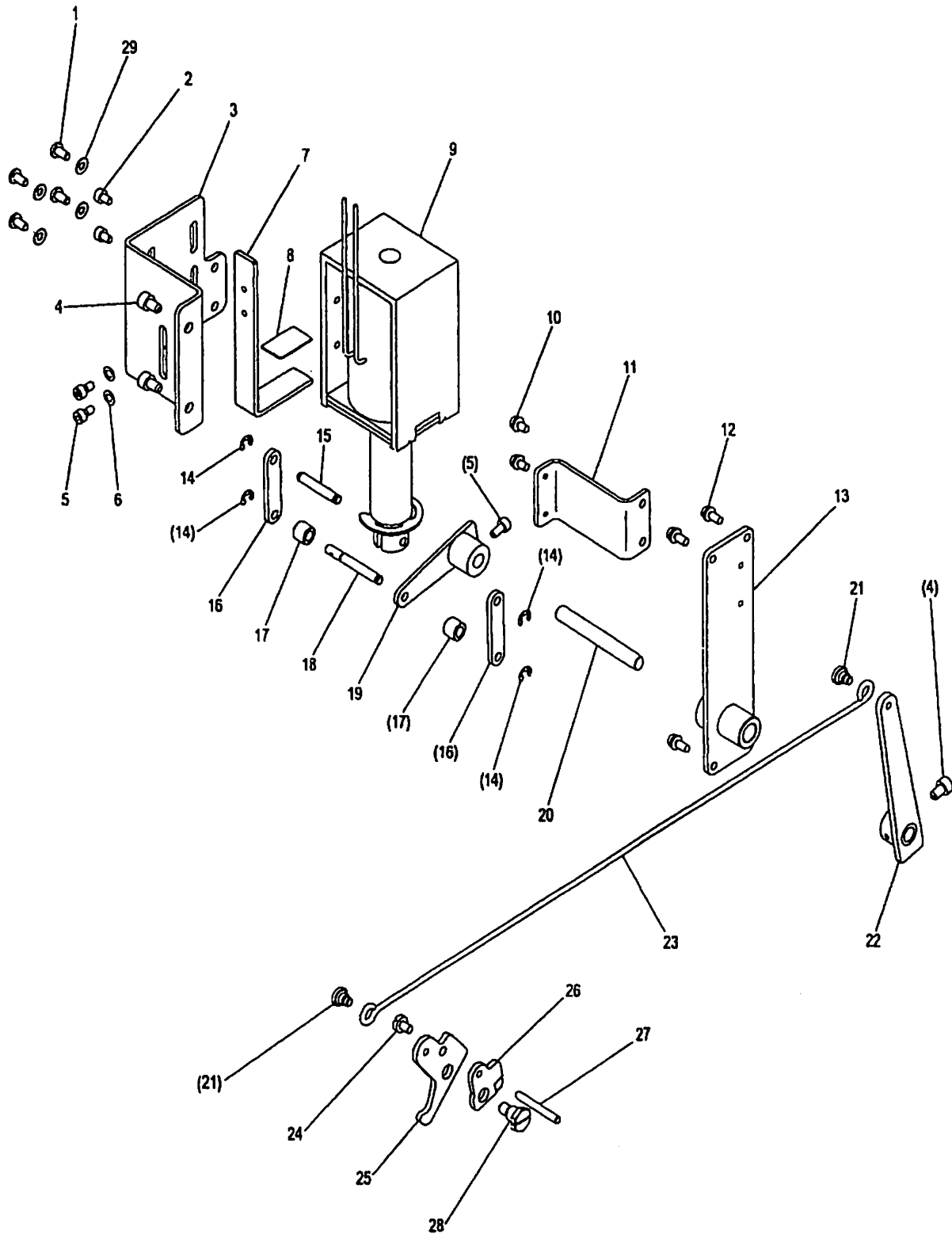

L. CENTER PRESSER FOOT LIFT MECHANISM

Fig. No.	Part No.	Description	Pcs.	Remarks
L01	HA700B2060	Screw 11/64(40) × 8	4	11/64(40) × 8
L02	HZ11040060	Bolt M4 × 6	2	M4 × 6
L03	HMO44F8001	Bracket	1	
L04	H415050080	Bolt M5 × 8	3	M5 × 8
L05	H415040080	Bolt M4 × 8	3	M4 × 8
L06	H6685D8001	Washer 4	2	M4
L07	HMO45F8001	Stopper	1	
L08	HMO49F8001	Rubber cushion	1	
L09	HMO40F7101	Solenoid assy	1	
L10	HZ11040080	Screw M4 × 8	2	M4 × 8
L11	HMO50F8001	Supporter	1	
L12	HZ11040100	Screw M4 × 10	4	M4 × 10
L13	HMO51F7101	Base plate assy	1	
L14	H007013040	E-type retaining ring 4	4	
L15	HMO37F8001	Pin	1	
L16	HMO46F8001	Link	2	
L17	HMO48F8001	Collar	2	
L18	HMO38F8001	Pin	1	
L19	HMO47F8001	Lever	1	
L20	HMO57F8001	Shaft	1	
L21	HA107H0662	Screw 3/16(28)	2	3/16(28)
L22	HMO55F8001	Lever	1	
L23	HMO34F8001	Link	1	
L24	HA107H1013	Screw 11/64(40) × 6.5	1	11/64(40) × 6.5
L25	HMO36F8001	Lifting lever	1	
L26	HA107H1012	Plate cam	1	
L27	HA700I2070	Pin	1	
L28	HA100H2050	Bolt 15/64(28)	1	15/64(28)
L29	H663FE8001	Spring washer 1L-4	4	1L-4

M. WIPER MECHANISM

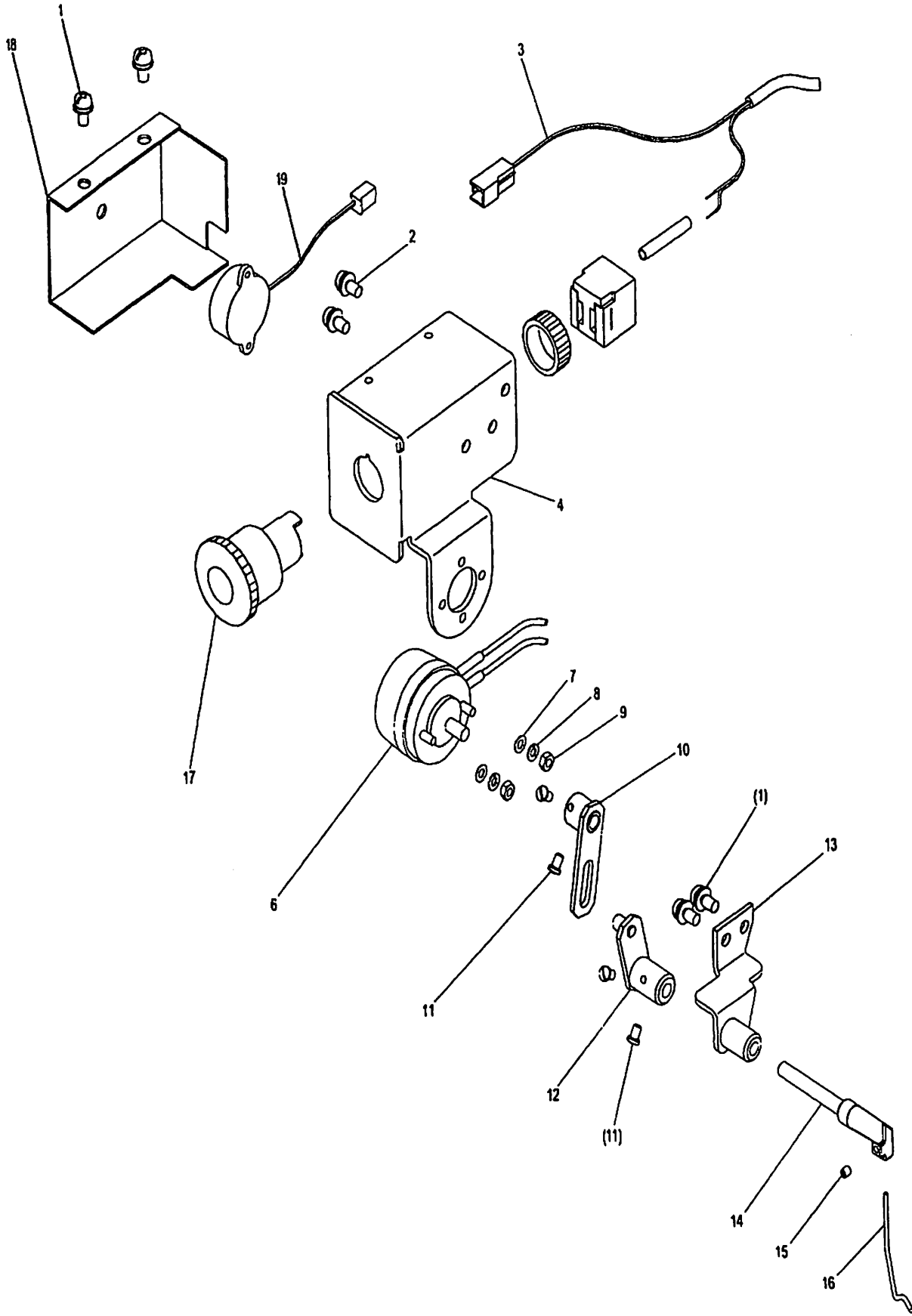

M. WIPER MECHANISM

Fig. No.	Part No.	Description	Pcs.	Remarks
M01	HZ11040080	Screw M4 × 8	4	M4 × 8
M02	HZ11040100	Screw M4 × 10	4	M4 × 10
M03	HMO21H7101	Cable (stop BZ)	1	
M04	HMO13H8001	Bracket	1	
M05	H6642I8001	Lock ring	1	
M06	HMO15H7101	Solenoid (wiper)	1	
M07	H668CE8001	Washer 3	2	M3
M08	H668BE8001	Spring washer 3	2	M3
M09	H003001030	Nut M3	2	M3
M10	HMO09H8001	Wiper crank 1	1	
M11	H6643C8001	Screw 1/8(44) × 4.5	4	1/8(44) × 4.5
M12	HMO31H8001	Wiper crank 2	1	
M13	HMO24H7101	Wiper adapter	1	
M14	HMO27H8001	Wiper shaft	1	
M15	H431030040	Screw M3 × 4	1	M3 × 4
M16	HMO29H8001	Wiper	1	
M17	H6636I8001	Push button	1	
M18	HMO06H8001	Cover	1	
M19	HMO07H7101	Buzzer assy	1	

N. OIL LUBRICATION MECHANISM

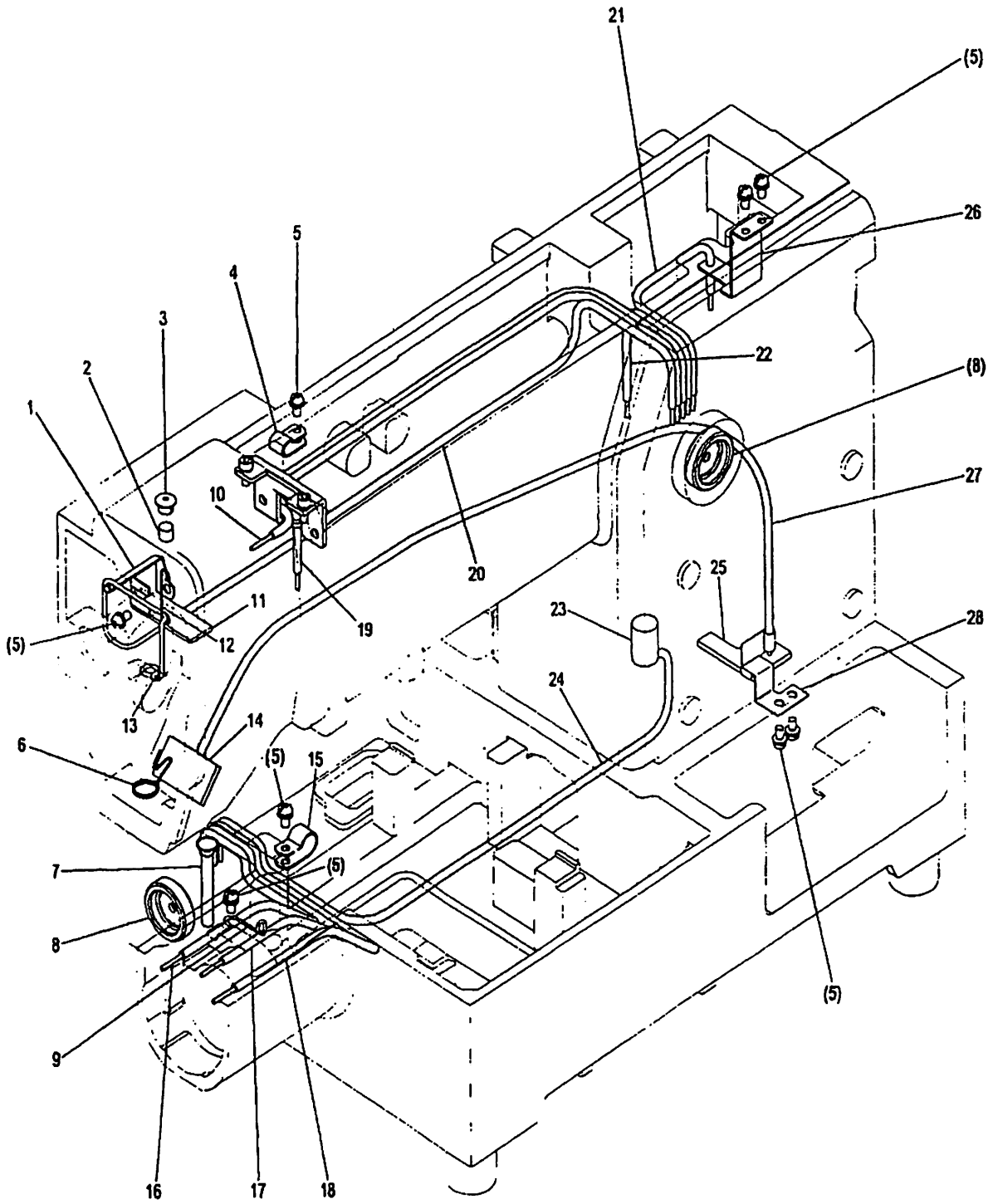

From the library of: Diamond Needle Corp

N. OIL LUBRICATION MECHANISM

Fig. No.	Part No.	Description	Pcs.	Remarks
N01	H6611H8001	Holder	1	
N02	H6646H8001	Felt	1	
N03	H2000M0090	Cap	1	
N04	H6679D8001	Nylon clip AB-3N	1	
N05	HZ11040080	Screw M4×8	8	M4×8
N06	HA300I2060	Holder	1	
N07	H6613H8001	Pipe	1	
N08	H6614H8001	Oil gauge	2	
N09	H6612H8001	Holder	1	
N10	H6616H7101	Oil pipe assy(F)	1	
N11	H6634H8001	Felt	1	
N12	HM008I8001	Holder	1	
N13	H3200G2030	Holder	1	
N14	H6641H8001	Felt	1	
N15	H6648I8001	Nylon clip AB-6N	1	
N16	H6619H7101	Oil pipe assy(hook left)	1	
N17	H6622H7101	Oil pipe assy(hook center)	1	
N18	H6625H7101	Oil pipe assy(hook right)	1	
N19	H6628H7101	Oil pipe assy(eccentric cam)	1	
N20	HM005I7101	Oil pipe assy(needle bar)	1	
N21	H6635H7101	Oil pipe assy(connect rod)	1	
N22	H6638H7101	Oil pipe assy(C)	1	
N23	H6634H8001	Felt	1	
N24	H6642H7101	Oil pipe assy(R)	1	
N25	H6606H8001	Felt	1	
N26	H6609H8001	Holder	1	
N27	H6631H7101	Oil pipe assy(circulation)	1	
N28	H6605H8001	Holder	1	

P. ELECTRICAL PARTS

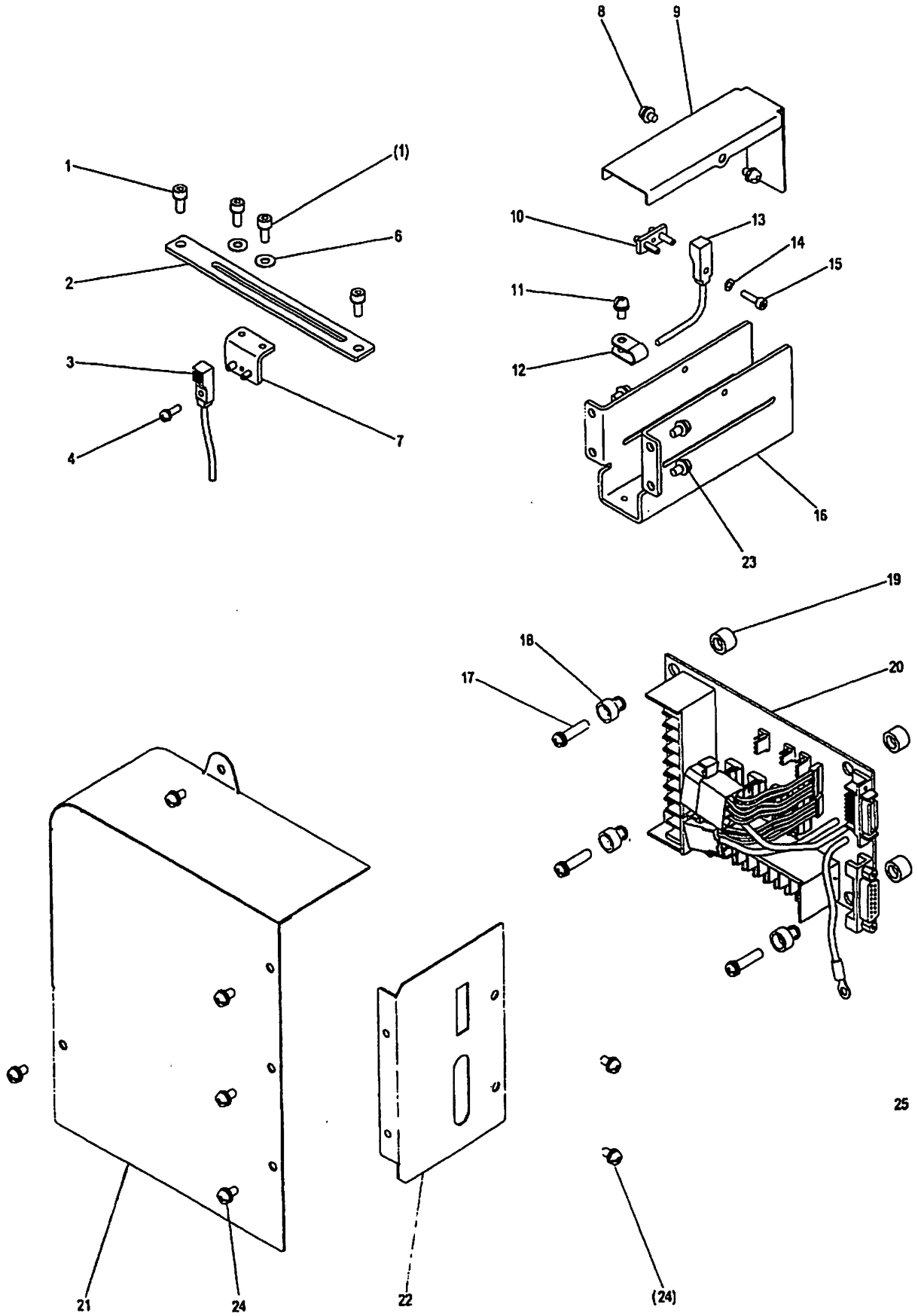

From the library of: Diamond Needle Corp

P. ELECTRICAL PARTS

Fig. No.	Part No.	Description	Pcs.	Remarks
P01	H415040100	Bolt M4×10	4	M4×10
P02	H6656D8001	Detector X mouting plate	1	
P03	H6658D8001	Detector X	1	
P04	HZ11030100	Screw M3×10	1	M3×10
P06	H6684D8001	Washer 4	2	M4
P07	H6657D8001	Holder plate assy X	1	
P08	HZ11040060	Screw M4×6	2	M4×6
P09	H6666D8001	Detector cover Y	1	
P10	H6676D7101	Holder plate assy Y	1	
P11	HZ11040080	Screw M4×8	1	M4×8
P12	H6679D8001	Nylon clip AB-3N	1	
P13	H6670D8001	Detector Y	1	
P14	H668CE8001	Washer 3	1	M3
P15	H415030120	Bolt M3×12	1	M3×12
P16	H6665D8001	Detector bracket Y	1	
P17	HZ11040200	Screw M4×20	4	M4×20
P18	H6607I8001	Nylon bush	4	
P19	H6608I8001	Nylon bush	4	
P20	H6606I8001	Print circuit board	1	
P21	H6611I8001	Circuit board cover	1	
P22	H6634I8001	Connector panel	1	
P23	HZ11040100	Screw M4×10	4	M4×10
P24	HZ11040080	Screw M4×8	7	M4×8

R. ACCESSORIES

Fig. No.	Part No.	Description	Pcs.	Remarks
R01	HM010C8001	Needle DPX×17#18	4	DXP×17#18
R02	H6685C8001	Bobbin	3	
R03	H6620J8001	Head rest	1	
R04	H6658B8001	Rubber cushion	4	
R05	HA300J2370	Cotton stand assy	1	
R06	HM027K8001	Foot switch	1	
R07	H007013025	E-type retaining ring 2.5	5	M2.5
R08	HA704S0654	Owner's manual	1	
R09	H6632J8001	Cord tie	1	
R10	H6622J8001	Cord tie	2	
R11	H6611J8001	Hexagonal wrench 4	1	M4
R12	H3200L0060	Hexagonal wrench 3	1	M3
R13	H3200L0050	Hexagonal wrench 2.5	1	M2.5
R14	H6612J8001	Hexagonal wrench 1.5	1	M1.5
R15	H3200L0070	Hexagonal wrench 1/16"	1	M1/16"
R16	H6619J8001	Polyethylene cover	1	
R17	HA300J2210	Screw drive (small)	1	
R18	HA300J2200	Screw drive (middle)	1	
R19	HA300J2070	Screw drive (large)	1	
R20	HA300J2220	Spanner 10-14	1	M10-14
R21	H200400069	Oiler with oil	1	
R22	H415060550	Bolt M6×55	4	M6×55
R23	H415060120	Bolt M6×12	4	M6×12
R24	H6642J8001	Washer 6.5-18	4	6.5-18
R25	H005008060	Spring washer 6	4	M6
R26	H003001060	Nut M6	4	M6
R27	H6639J8001	Hinge	2	
R28	H007013050	E-type retaining ring 5	2	
R30	JGD0700000	Pneumatic assy	1	
R31	H6621J8001	Oil pan	1	
R32	H6628J8001	Wooden screw 3.1×16	4	M3.1×16
R33	H6627J8001	Tie holder	2	
R34	H6618J8001	Staple	4	

SHANGHAI HUIGONG NO.3 SEWING MACHINE FACTORY

ADD: 1418, Yishan Road, Shanghai, China

Zip Code: 201103

Overseas Business: TEL: 86-21-64853303 FAX: 86-21-64854304

E-mail: highlead@online.sh.cn <http://www.highlead.com.cn>

The description covered in this manual is subject to change for improvement of the commodity without notice

2008.11. Printed