

HIGHLEAD

GL13118-1

Blindstitch machine

Instruction Manual
Parts Catalog

SHANGHAI HUIGONG NO.3 SEWING MACHINE FACTORY

INDEX

1. Brief Instruction.....	1
2. Main Specification	1
3. Installation and Preparation.....	1
A. Installation.....	1
i. Take Machine Head out	
ii. Install the Stand	
iii. Install the Machine	
iv. Install the Cloth Plate Assy	
B. Preparation.....	2
i. Clean the Machine	
ii. Check the Machine	
iii. Lubricate the Machine	
4. Operation.....	3
A. Rotation and Speed.....	3
B. Needle Selection.....	3
C. Needles and Thread.....	3
D. Replace Needles.....	3
E. Threading.....	4
F. Pressing in and out.....	4
G. Skip Stitch Device.....	4
H. Feed Dog Adjustment.....	4
5. Adjustment.....	4
A. Adjust Stitch Length.....	5
B. Adjust Needle Penetration.....	5
C. Adjust the Pressing Plate.....	5
D. Adjust Needle and Needle Plate.....	5
i. Back and Forth Position	
ii. Up and Down Position	

iii.	Left End Position	
iv.	Needle Stroke	
E.	Spreader Position Adjustment.....	7
i.	Standard Position	
ii.	Left and Right Position	
iii.	Up and Down Position	
iv.	Back and Forth Position	
F.	Feed Lifting Position Adjustment.....	8
i.	Left and Right Position	
ii.	Back and Forth Position	
iii.	Assembling and Disassembling the Feed Lifting Wheel	
G.	Adjust Presser Feet Pressure.....	10
H.	Adjust Thread Tension.....	10
6.	Machine Supply.....	10
7.	Standard Accessories.....	10
8.	Parts List	
A.	Arm and Bed	
B.	Main Shaft Mechanism	
C.	Feed Dog and Needle Shaft Assy	
D.	Spreader Mechanism	
E.	Needle Plate Assy	
F.	Presser Foot Mechanism	
G.	Feed Lifting Mechanism	
H.	Knee Lifter Mechanism	
I.	Thread Tension Mechanism	
J.	Cloth plate Assy	

1. Brief Instruction

This model is designed with needle bar to take up thread and spreader mechanism to catch thread loop producing Stitch 103 and straight blind stitch seam by one arched needle and one spreader. Also it is equipped with regulation mechanism to adjust presser foot pressure, thread tension, stitch length, feed lifting, presser foot left and feed ratio for blind stitching light to medium heavy weight fabrics or sewing operations, such as trousers cuff, lap, fore pant of suit, etc.

It is requested to read this instruction manual carefully before operating the machine, for best machine performance.

2. Main Specification

(1)Max. Sewing speed	2500 r.p.m.
(2)Max. Stitch length	3mm - 8mm
(3)Feed ratio	1:1 2:1
(4)Presser foot lift	7mm
(5)Needle	GL×1 NM75-100 (LW×6T 3#-4#)
(6)Thread	14.5-7.5 tex cotton 14.8-7.4 tex terylene cotton
(7)Motor power	270W
(8)Measurements	510×360×245
(9)Gross weight	24.5kgs

3. Installation and Preparation

A. Installation

i. Take Machine Head out

When taking machine head out of the packing, be careful not to damage the exposed parts such as thread tension, thread guide etc.

Don't dispose of any packing material before checking up with the packing list in order to avoid any parts missing.

ii. Install the Stand

- First assemble back brace and treadle brace with left and right legs, then set treadle holders to treadle brace.
- Install motor onto table.
- Set table onto stand with washers and wood screws.
- Connect motor and treadle lever by draw bars. After adjusting treadle position, tighten the nuts for draw bar joint and treadle.

iii. Install the machine

- a. Put Cushion D, Brace C, Cushion B, Cushion E, Machine Head A onto the table, then put Bolt F through holes, Washer G and Washer H and tighten Nut I (Fig. 1) finally.
- b. Assemble Knee Lifting Bar K, Bushing L to long shaft. Tighten the bushing when 1 cm is obtained between the knee lifting bar and table (fig. 2).
- c. Set V-belt N to the machine pulley and align motion pulley with machine pulley. After adjusting motor position and the V-belt tension, tighten the nuts for the motor.
- d. Set motor switch on the right underside of the table.

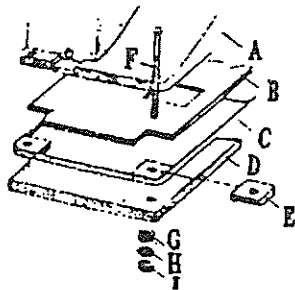

Fig. 1

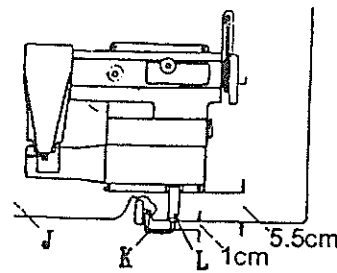

Fig.2

- iv. Install the cloth plate assy (Fig. 3)
 - a. Set Support A to the machine head by Screw B.
 - b. Tighten Screw G into Shaft C, then put Shaft C into the hole of Support A, set Retainer F and tighten Screw H. Be sure the cloth plate rotates freely.
 - c. Insert Pin D into Bushing K and tighten the screw.
 - d. Adjust the height of Cloth Plate E and tighten Screw I.

B. Preparation

- i. Clean the machine
Clean off anti-rust grease from the machine parts with soft cloth and gasoline before using a new machine or a machine idle for a long time.
- ii. Check the machine
The machine parts may get loose or deformed by strong jolt in transportation. Check the machine carefully by turning machine pulley to see if there is any collision, noise or looseness. Be sure the machine is in good condition before running it.
- iii. Lubricate the machine
Fill the oiling holes with a few drops of machine oil before operating the machine (Fig. 4), making sure all the movable parts are well lubricated, then run the machine at low speed for a few minutes. A new machine is requested

to be oiled at least twice per shift. To avoid contamination on sewing fabrics be sure to clean the machine after oiling and running idle.

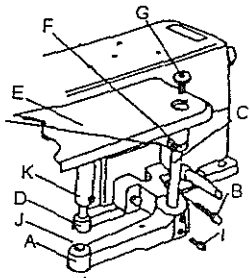

Fig. 3

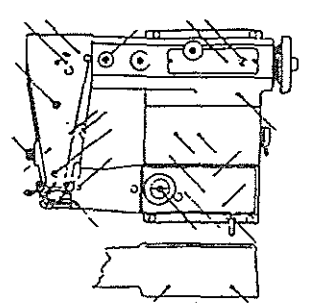

Fig. 4

4. Operation

A. Rotation and Speed

The machine pulley should rotate clockwise viewing from right side of the machine. It is suggested to use a new machine at a speed less than 1800r.p.m. for the first 60 days. After this period you may operate the machine at a higher speed.

B. Needle Selection

Be sure to use the needles $GL \times 1$ NM75-100(LW \times 6T 3#-4#). A different needle size is required for different sewing fabric.

C. Needle and Thread

Please refer to the table below for the selection of needles and thread.

Needle Size	Thread Size		Sewing Fabric
	Cotton	Terylene Cotton	
75	7.5tex	7.4tex	130 Plain cloth, terylene cotton, nylon
90	9.5tex		Cotton, wool, medium heavy fabric
100	14.5tex	14.8tex	Corduroy, heavy wool heavy duty fabric

D. Replace Needles (Fig. 5)

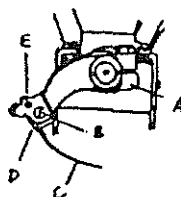

Fig. 5

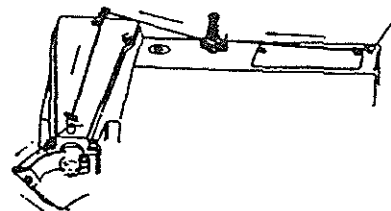

Fig. 6

After turning machine pulley to bring the needle to left end, and adjust the feed lifting dial to a, loosen Screw B and replace the old needle with a new one. Make sure the needle shank is in the center of the left guide slot of the needle plate. Finally tighten Screw B and adjust the feed lifting dial back to the original position. After replacing the needle properly. If there is a bar on needlepoint or the needle is bent or blunt, you must replace it for proper sewing performance.

E. Threading (Fig. 6)

Turn the machine pulley to bring the needle to the left end and thread the machine as shown in the figure.

F. Pressing in and out

Before sewing push Knee Lifter A by knee rightward (Fig. 7) to bring down Presser Foot B and Feed Lifting Wheel C, then insert sewing fabric under Needle Plate E. Sewing fabric will be pressed under the presser foot when releasing the knee lifter.

After sewing turn* machine pulley to bring the needle to the left end, then turn back the machine pulley to let the thread down from the spreader. Sewing fabric can be taken out easily when lowering the presser foot by kneec.

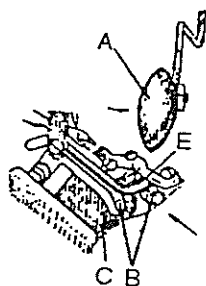

Fig. 7

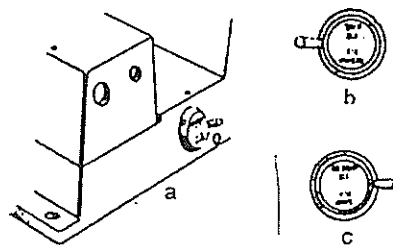

Fig. 8

G. Skip Stitch Device

Feed ratio adjusting knob can be found at lower right side of the machine (Fig. 8a). When skip stitch is required (blind stitch ratio 2:1), turn the handle forward (to the operator), as shown in Fig. 8b. Skip stitch is finally available for light weight material. For non-skip stitch, turn the handle back, as shown in Fig. 8c.

H. Feed Dog Adjustment (Fig. 9)

Feed dog lifting regulator can be found on the right side of machine arm. Turn Feed Dog Lifting Regulation A clockwise to raise feed dog for heavy weight material. Turn Feed Dog Lifting Regulator counterclockwise to lower the feed dog for light weight fabric.

5. Adjustment

A. Adjust stitch length (Fig. 10)

Press down the button by left hand while turning the machine pulley by right hand. After you hear a click, keep depressing button and turning machine pulley until the figure on left side of machine pulley aligns with the scale. If the stitch length required is smaller than the figure shown on the scale, turn the machine pulley clockwise, or turn counterclockwise for longer stitch length.

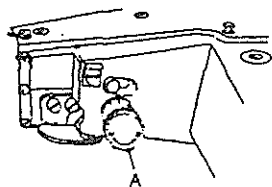

Fig. 9

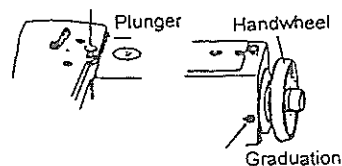

Fig. 10

B. Adjust Needle Penetration

A feed lifting wheel regulator can be found in the middle of lower arm of the machine. It consists of Knob A and Indicator B (Fig. 11). The height of Feed Lifting Wheel C decides stitching thickness. Adjust stitching as per the exposed stitches. Turn the knob clockwise to lower the feed lifting wheel for reduced stitching thickness, or turn the knob counterclockwise to raise the feed lifting wheel for increased stitching thickness.

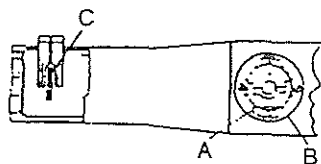

Fig. 11

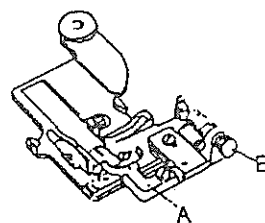

Fig. 12

C. Adjust the Pressing Plate (Fig. 12)

This blind stitch machine is equipped with an all-purpose needle plate available for tooth light and heavy weight fabrics. When sewing adjust Pressing Plate A as per the thickness of the sewing material. When adjusting, turn Screw B clockwise for increased pressure for heavy weight fabric, or turn Screw B counterclockwise for reduced pressure for light weight fabric.

D. Adjust Needle and Plate

i. Back and Forth Position

Needle B should be in the center of Left Guide Slot C of the needle plate (Fig. 13a). If the needle is not positioned properly, loosen Screw A and move

Needle Clamp D back and forth (Fig. 13b). After adjustment, tighten the screw again.



Fig. 13a



Fig. 13b

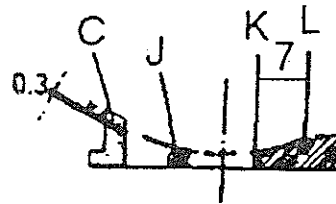

Fig. 14

ii. Up and Down Position (Fig. 14)

There are three checkpoints for the up and down position of the needle:

- a. The clearance between the needle and the bottom of Left Guide Slot C should be less than 0.3mm;
- b. The needle should be just in touch with the bottom of the right guide slot (KL arched surface). Wrong positioning will cause the problems like needle like breakage, thread breakage, skipping, etc. When adjusting, loosen Screw H and I to move the needle plate up and down to the correct position. After adjustment, tighten screws again. (Fig.15)

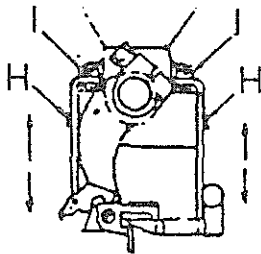

Fig. 15

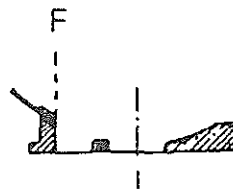

Fig. 16

iii. Left End Position

The needlepoint should be flush with Right Side F of the left guide slot of the needle plate (Fig. 16)

When adjusting, turn the left end pulley to bring the needle to the left end. If not positioned correctly, loosen screw A (Fig. 13b) and turn the needle clamp. Tighten the screw when the proper position is obtained.

iv. Needle Stroke

The needle stroke decides the right end of the needle movement. When the needle moves to the right end, the distance between the needlepoint and the right side of the needle plate should be almost 2mm (Fig. 17)

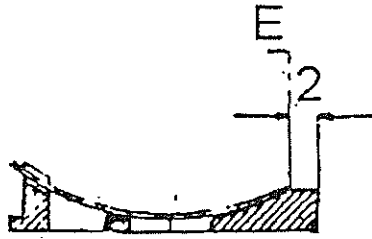

Fig. 17

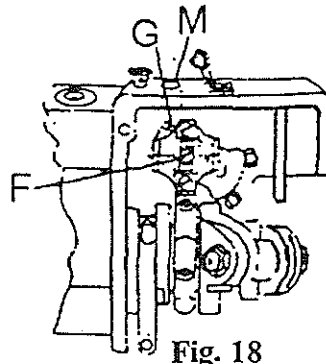

Fig. 18

When adjusting, remove the cover of the upper arm, insert the screwdriver into Hole H, loosen Screw G and turn Pin F till the correct needle stroke is obtained. (fig. 18)

E. Spreader Position Adjustment

i. Standard Position

The standard position of the spreader is obtained by Crank A and Shaft B. When assembling align the dot on the crank with the center of the V slot of the shaft. (fig. 19)

ii. Left and Right Position

When the long finger point of the spreader touches the center line of the needle, the distance between the center of the long finger point and the left edge of the needle hole should be almost 2mm. (Fig. 20)

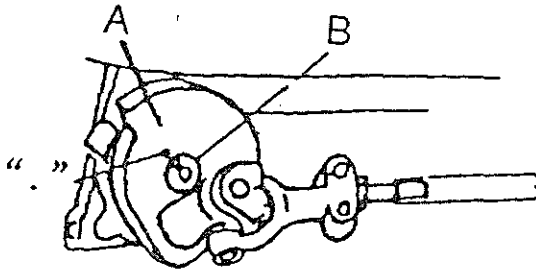

Fig. 19

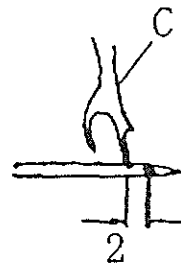

Fig. 20

When adjusting

- Loosen Bolt E, and move Eccentric Bushing D left and right. Tighten Bolt E again when the correct position is obtained. (Fig. 21)
- Turn the machine pulley to see if Spreader F collides with Point G of Needle Guard K (Fig. 22). If it does move the eccentric bushing left a little.
- Adjust the relative position for the dot on the crank to the V slot. When adjusting the left and right position of the spreader, you must base on the specific conditions and choose suitable steps for adjustment.

iii. Up and down Position

The clearance between the long finger point and the needle should be less

than 0.05mm when crossing (Fig. 20).

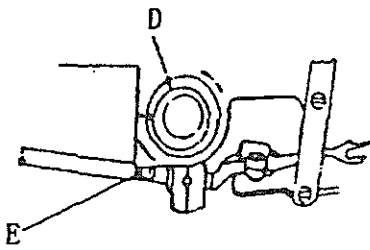

Fig. 21

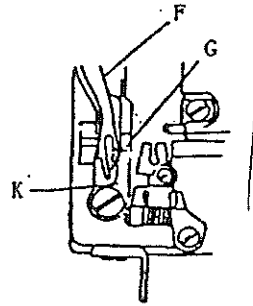

Fig. 22

When adjusting

a) Loosen Bolt E (Fig. 21) and turn Eccentric Bushing D till the clearance is obtained with the spreader at the right end.

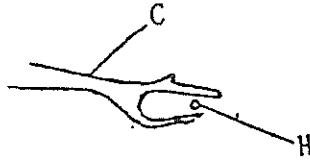

Fig. 23

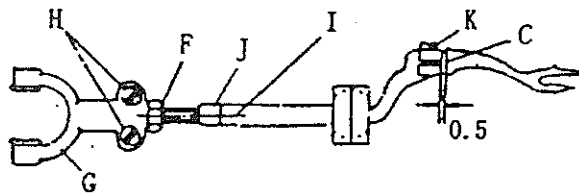

Fig. 24

b) After adjustment, make sure the needlepoint should be in the center of the opening of spreader C with the spreader at the left end (Fig. 23)

iv. Back and Forth Position

Adjust the back and forth position as follows:

- a. Adjust the position of the dot point on the crank in relation to the V slot of the shaft (Fig. 19).
- b. Loosen Nut F and Screw H and turn the spreader to adjust the position.

If the above adjustment still cannot come to satisfaction, loosen screw K and move the spreader slightly back or forth for optimum position. Be sure the clearance between the front edge of the spreader shaft and Spreader C should be less than 0.5mm.

F. Feed Lifting Position Adjustment

i. Left and Right Position

The center of Feed Lifting Wheel C should coincide with the center of the V slot of the pressing plate (Fig. 25 & 26).

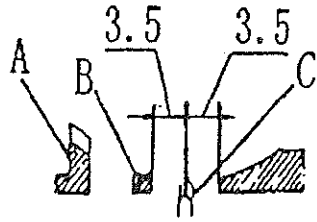

Fig. 25

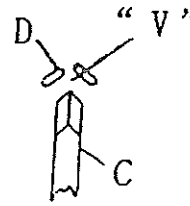

Fig. 26

Adjustment is to be done as follows (Fig. 27):

- a. Loosen Screw C and turn Screw B, making sure Adjusting Bar A will not move axially but can rock freely. Then tighten Screw C again.

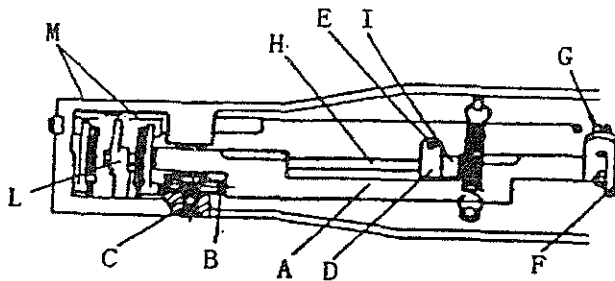

Fig. 27

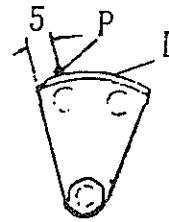

Fig. 28

- b. Loosen Screw E and Screw G and move the feed lifting shaft left or right. Tighten Screw E and G again when the position (Fig. 25), making sure the feed lifting shaft will not move axially but can rock freely, and it will not collide with left and right presser feet.
- c. Loosen Screw A and move Pressing Plate D left and right, making sure the center of the V slot of the pressing plate coincides with the center of the feed lifting wheel. After adjusting, tighten the screw again.

ii. Back and Forth position

The back and forth position of the feed lifting wheel is based on the first stitch. When Needle Point P is crossing the center of the feed lifting wheel, the distance between the backside of Feed Lifting Wheel L and the center of the needle should be 5mm (Fig.28).

When adjusting turn the machine pulley to bring the needle point to cross the center of Feed Lifting Wheel L (Fig. 28). Then loosen Screw G and rotate Feed Lifting Shaft H to make sure the backside of Feed Lifting Wheel is 5mm from the needle center (Fig. 28). After adjusting, tighten Screw G again.

iii. Assembling and Disassembling the Feed Lifting Wheel

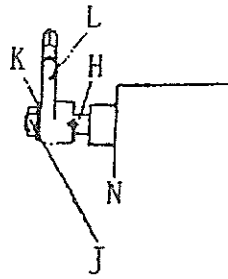

Fig. 29

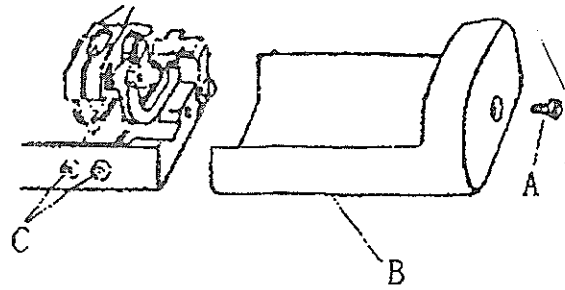

Fig. 30

When assembling and disassembling Feed Lifting Wheel L, pay attention to the left twisted engagement between the screw thread on the left end of Feed Lifting Shaft H and Nut J and be sure not to damage the screw thread. The V notch must align with Pin N in assembling (Fig. 29)

G. Adjust Presser Foot Pressure

The pressure of the presser foot should be adjusted as per the thickness of sewing fabric. As a rule the pressure should be higher for heavy weight material and lower for light weight material. When adjusting remove Screw A and Cover B, and turn Nut C (Fig. 30) clockwise for higher pressure or counterclockwise for lower pressure.

H. Adjust Thread Tension

Thread tension is much related with sewing quality. Too high tension will cause problems such as puckering, thread breaking, etc, while too low tension will cause skipping, floating and uneven stitches. As a rule longer stitches need lower thread tension and shorter stitches need higher thread tension.

When adjusting, rotate Nut L clockwise for more thread tension or counterclockwise for less thread tension (Refer to Fig. 6).

6. Machine Supply

Machine can be supplied as head only or complete.

7. Standard Accessories

(1)Screw Driver	2pcs (1 each for long and short)
(2)Oiler	1pc
(3)Needle	2pcs
(4)Spreader	1pc
(5)Pad	4pcs
(6)Cushion	2pcs
(7)Base	1pc

(8)Knee Lifter Assy	1set
(9)Screw	4pcs
(10)Nut	4pcs
(11)Washer	4pcs
(12)Thread Stand	1set
(13)Instruction Manual	1pc

PARTS LIST

1. ARM & BED

Ref.Nos.	Parts No.	Description	Quantity
1	GK1-2	Arm cover	1
2	GS1-2	Screw	1
3	GS7-2	Cone screw	2
4	GK3-2	Side cover	1
5	S40	Screw	2
6	GK4-2	Back cover	1
7	GS6-2	Screw	1
8	GK2-2	Top cover	1
	GR3-2	Pipe	2
9	S40	Screw	4
10	GR10-2	Rubber plug	1
11	GQ1-2	Bed	1
12	GK6-2	Oil cap	1
13	GS6-2	Screw	1
14	GK5-2	Bed cover	1
15	GS2-2	Screw	1
16	GR14-2	Rubber cushion	1
17	GR15-2	Rubber cushion	1
18	GR16-2	Seat	1
19	GR17-2	Rubber cushion	1
20	GS103-2	Screw	4
21	GR18-2	Rubber cushion	4
22	GR201-2	Washer	4
23	GL101-2	Nut	4

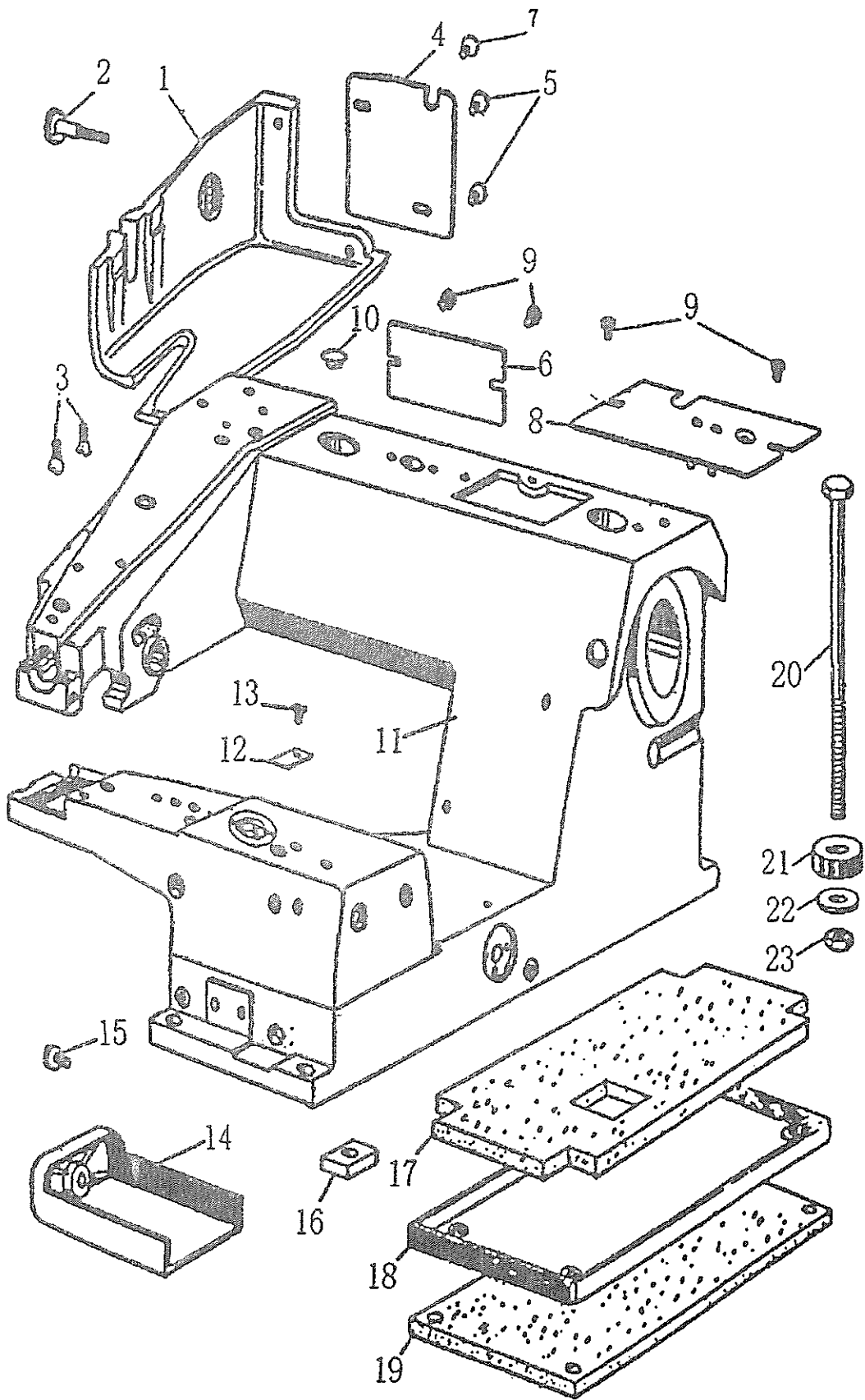

2.Main Shaft Mechanism

Ref.Nos.	Parts No.	Description	Quantity
1	G01-2	Bushing (left)	1
2	GS37	Set screw	2
3	GR4-2	Felt	2
4	GR1-2	Plug	1
5	G03-2	Balance	1
6	GS8-2	Set screw	1
7	GS9-2	Set screw	1
8	G07-2	Bushing (right)	1
9	GZ2-2	Main shaft	1
10	G04-2	Eccentric bushing	1
11	GS50	Set screw	1
12	GS50	Set screw	1
13	GH1-2	Link	1
14	GX3-2	Pin	1
15	G05-2	Eccentric bushing	1
16	GX2-2	Slide pin	1
17	G06-2	Gear bushing	1
	GC1-2	Gear	1
	GX102-2	Rivet	3
18	GC2-2	Pinion	1
19	GS43	Set screw	2
20	GC4-2	Idle pinion	1
	GC3-2	Idle gear	1
	G010-2	Gear bushing	1
	GZ3-2	Gear bar	1
	GX103-2	Rivet	3
21	G09-2	Eccentric bushing	1
22	GS37	Set screw	1
23	G08-2	Collar	1
24	GS43	Set screw	2
25	GP1-2	Hand wheel	1
26	GS37	Set screw	2

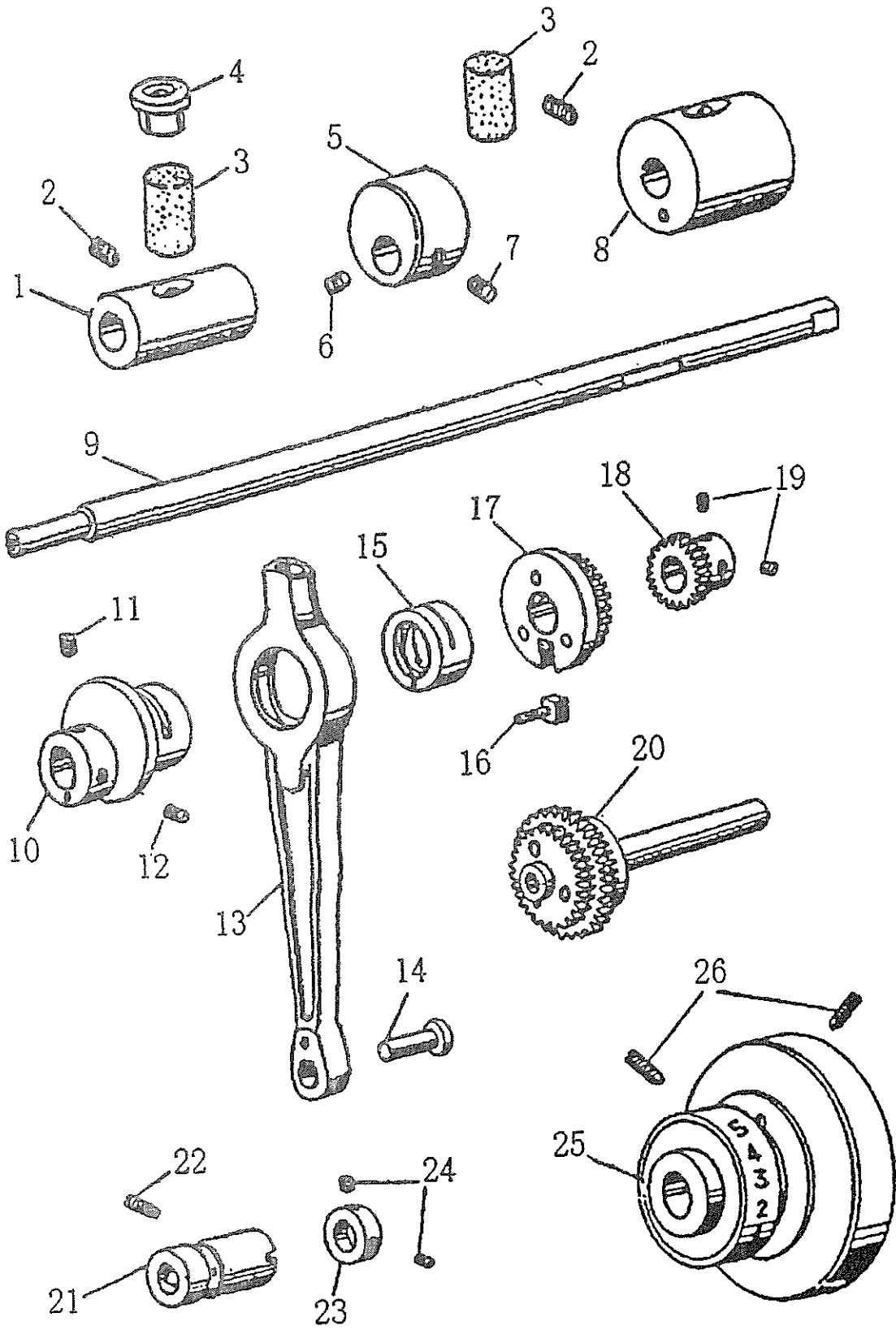

3.Feed Dog & Needle Shaft Assy.

Ref.Nos.	Parts No.	Description	Quantity
1	GR164	Oil ring	2
2	GR11-2	Felt	1
3	GR11-2	Felt	1
4	GR30-2	Needle clamp	1
5	CS15-2	Set screw	1
6	GZ6-2	Needle shaft	1
7	G019-2	Collar	1
8	GS43	Set screw	2
9	G018-2	Bushing (front)	1
10	G017-2	Bushing (back)	1
11	GS8	Set screw	2
12	GH4-2	Crank	1
13	GS61	Set screw	1
14	GS55	Screw	1
15	GR31-2	Needle clamp plate	1
	GR32-2	Thread guide	1
16	GS16-2	Set screw	1
17	GV1-2	Needle	1
18	GR29-2	Pin	1
	GR25-2	Cap (upper)	1
	GR26-2	Connectiong rod	1
	GR27-2	Cap (lower)	1
	G015-2	Eccentric bushing	1
	G014-2	Slide bushing	1
	G013-2	Eccentric bushing	1
19	GS14-2	Screw	2
20	GS55	Screw	2
21	GS13-2	Set screw	1
22	GS12-2	Set screw	2
23	GR21-2	Steel ball	1
24	GW3-2	Spring	1
25	GR28-2	Cover	1
26	GS44	Screw	2

3.Feed Dog & Needle Shaft Assy.

Ref.Nos.	Parts No.	Description	Quantity
27	G016-2	Plunger	1
	GW5-2	Spring	1
	GX4-2	Pin	1
	GR24-2	Button	1
28	GS45	Set screw	2
29	GH2-2	Feed bar	2
30	GM1-2	Feed dog	1
31	GR202-2	Spring washer	1
32	GS10-2	Screw	1
33	GH3-2	Feed rock bar	1
	GZ5-2	Pin	1
34	GSC37	Set screw	1
35	GS11-2	Set screw	1
36	GZ4-2	Pin	1
37	G012-2	Eccentric bushing	1
38	G011-2	Bushing	1
39	GS45	Set screw	2
40	GR21-2	Steel ball	1
41	GW2-2	Spring	1
42	GR20-2	Knob	1
43	GS58	Set screw	2
44	GR19-2	Indicating plate	1

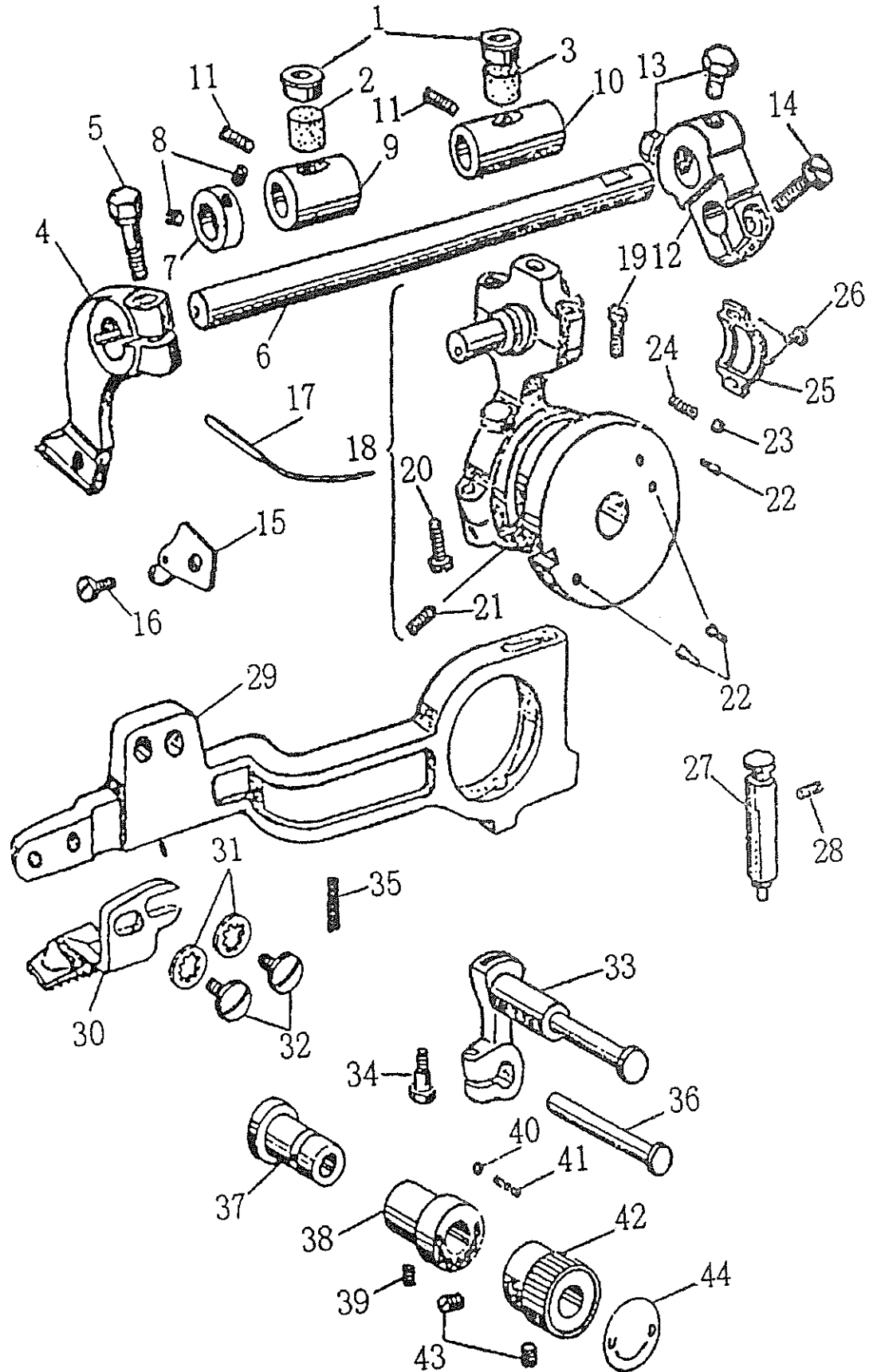

4. Spreader Mechanism

Ref.Nos.	Parts No.	Description	Quantity
1	G020-2	Position ring	1
	GZ7-2	Driving bar	1
	GR33-2	Felt	1
	GR34-2	Felt	1
	GR35-2	Joint (back)	1
2	GS19-2	Screw	2
3	L3	Nut	1
4	GS43	Screw	2
5	GR36-2	Joint (front)	1
6	GS20-2	Screw	2
7	GX5-2	Pin	1
8	GS18-2	Screw	1
	GH5-2	Crank	1
9	GR39-2	Rock arm (front)	1
	GR38-2	Rock arm (back)	1
	GR37-2	Ball	1
10	GZ8-2	Spreader bar	1
11	GL1-2	Nut	1
12	GS22-2	Screw	2
13	GS21-2	Set screw	1
14	GS25-2	Set screw	1
15	GS23-2	Set screw	1
16	GN1-2	Spreader	1
17	GZ9-2	Rock arm shaft	1
	G021-2	Eccentric bushing	1
18	GS17-2	Bolt	1

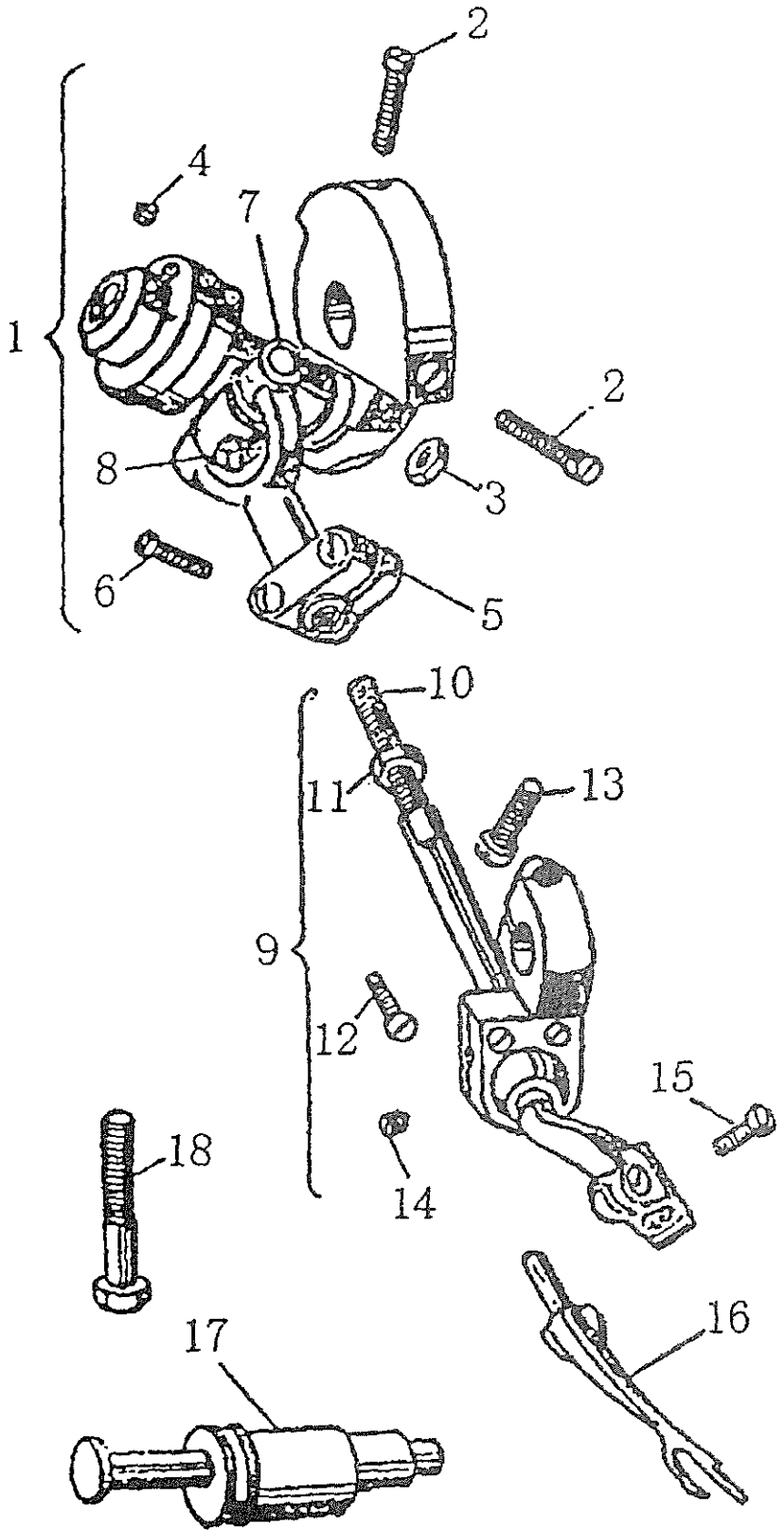

5. Needle Plate Assy.

Ref.Nos.	Parts No.	Description	Quantity
1		Needle plate assy.	1
2	GM2-2	Needle plate	1
3	GR46-2	Needle guard	1
4	S16	Screw	1
5	GR47-2	Feed guide	1
6	GR34-2	Screw	1
7	GR43-2	Feed retaining plate	1
8	GS31-2	Screw	1
9	GZ10-2	Bar	1
10	GR42-2	Supporting basket	1
11	S40	Screw	1
12	GW6-2	Spring	1
13	GS28-2	Adjusting screw	1
	GX6-2	Pin	1
14	GR48-2	Support	1
15	S40	Screw	1
16	GL2-2	Nut	1
17	GR45-2	Stud	1
18	GR44-2	Thread Retainer	1
19	GS33-2	Screw	1
20	GR49-2	Feed lifter	1
21	GR50-2	Feed lifter	1
	GR51-2	Feed lifter (round head)	1
22	GS27-2	Screw	1
23	GR40-2	Needle plate support	2
24	GS26-2	Screw	2
25	GS29-2	Set screw	2
26	GR203-2	Gasket	2
27	GS30-2	Set screw	2

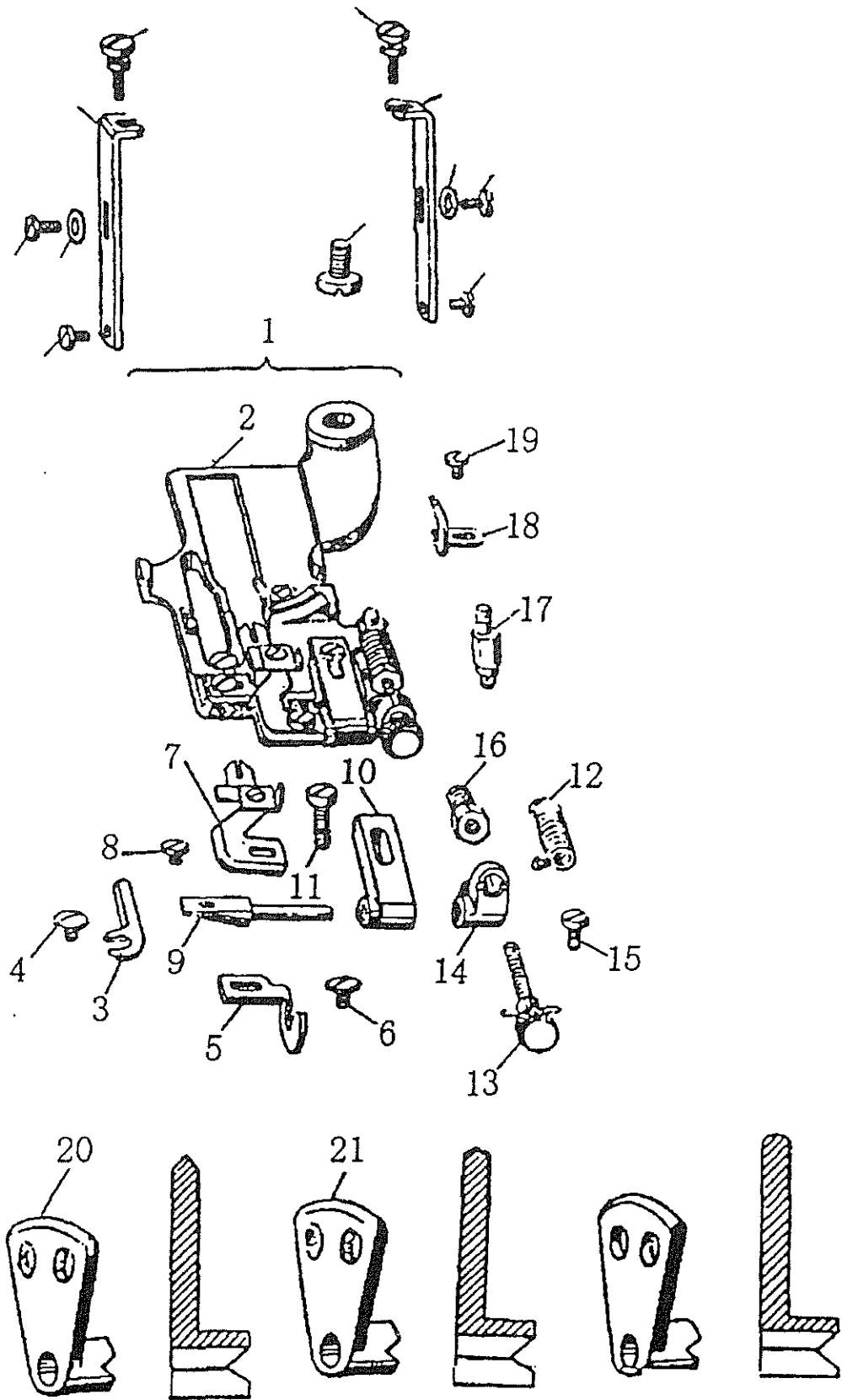

6. Presser Foot Mechanism

Ref.Nos.	Parts No.	Description	Quantity
1		Feed lifter	1
2	GR204-2	Spring washer	1
3	GL3-2	Nut	1
4	GX106-2	Pin	1
5	GZ11-2	Feed lifting shaft	1
6	GR53-2	Collar	1
7	GS037	Set screw	1
8	G022-2	Bushing	1
9	GR52-2	Adjusting bar	1
10	GS35-2	Cone screw	1
11	GS48	Set screw	1
12	GR54-2	Cone pin	1
13	S3	Set screw	1
14	GW7-2	Spring	1
15	GS36-2	Screw	1
16	GL5-2	Nut	1
17	GX7-2	Pin	1
18	GL4-2	Nut	1
19	GZ12-2	Presser lifting shaft	1
20	G024-2	Bushing	1
21	GS48	Set screw	2
22	G023-2	Collar	2
23	GS43	Set screw	1
24	GM3-2	Presser (left)	1
	GM4-2	Presser (right)	1
	GR59-2	Presser lifting lever (left)	1
	GR60-2	Presser lifting lever (right)	1
	GX9-2	Pin	2
25	GS45-2	Cone screw	2
26	GL8-2	Nut	2
27	GS43-2	Screw	2
28	GW9-2	Spring	2
29	GS44-2	Screw	2

6. Presser Foot Mechanism

Ref.Nos.	Parts No.	Description	Quantity
30	GL7-2	Nut	2
31	GR61-2	Support plate	2
32	GS030	Screw	1
33	GR55-2	Indicator	1
34	GS38-2	Screw	1
35	GR58-2	Knob	2
36	GR21-2	Steel ball	1
37	GW8-2	Spring	1
38	GS66	Screw	2

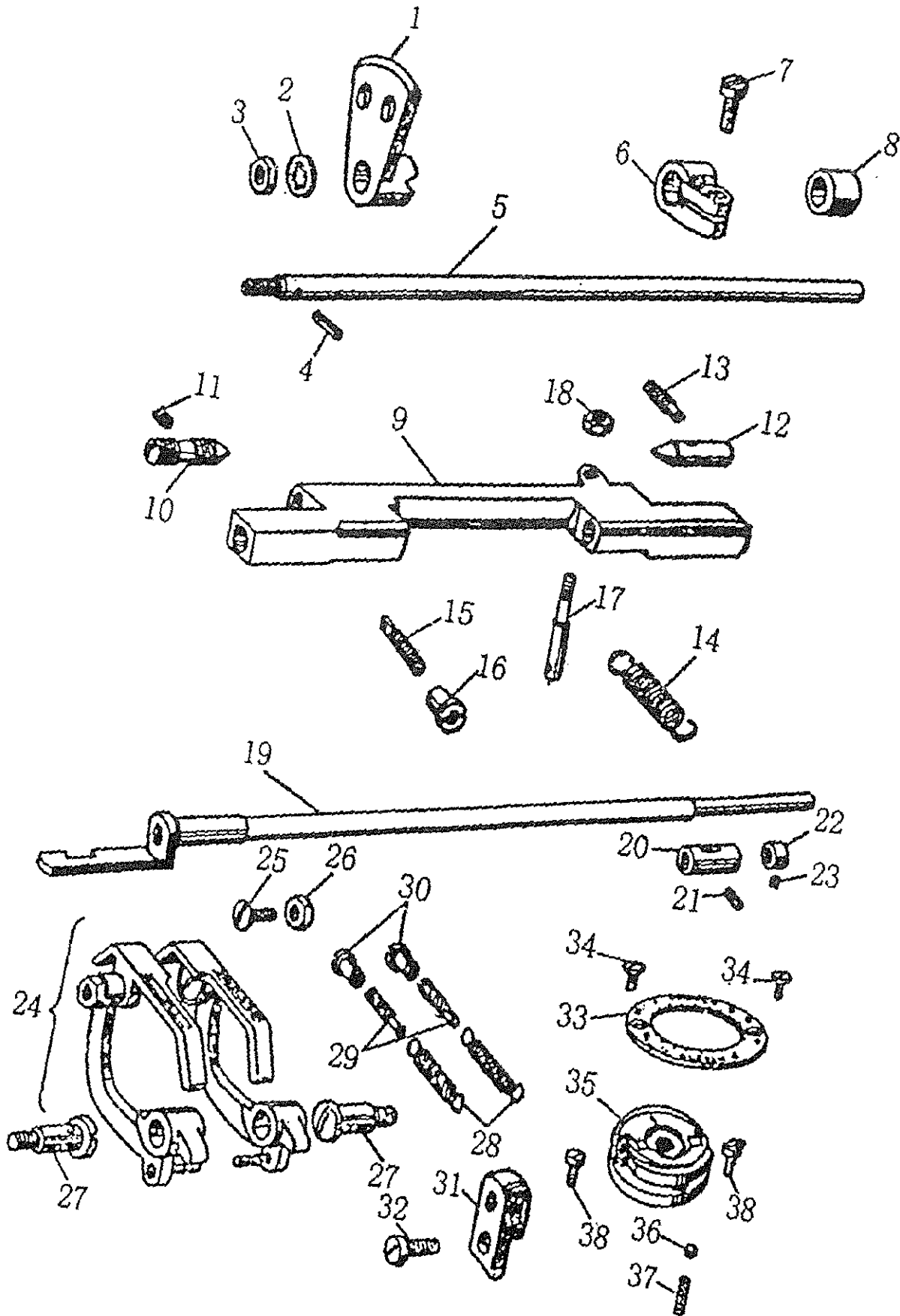

7. Feed Lifting Mechanism

Ref.Nos.	Parts No.	Description	Quantity
1	G028-2	Collar (left)	1
2	GS50	Set screw	2
3	GT1-2	Stop cam	1
4	GS48	Set screw	2
5	GS47-2	Screw	1
6	L1	Nut	1
7	G027-2	Bushing	1
	GS5-2	Gear	1
8	GX13-2	Rock shaft	1
9	GS48	Set screw	2
10	G026-2	Eccentric bushing	1
	GX107-2	Pin	1
11	G025-2	Collar (right)	1
12	GS50	Set screw	2
13	GZ14-2	Eccentric shaft	1
14	GR65-2	Retaining ring	1
	GX104-2	Pin	1
15	GS47	Screw	2
16	GR66-2	Knob	1
	GR67-2	Knob base	1
17	GS48	Set screw	2
18	GS12-2	Screw	2
19	GR68-2	Indicating plate	1
20	GR64-2	Bushing	1
21	GW3-2	Spring	1
22	GR21-2	Steel ball	1
23	GH7-2	Crank	1
24	GS037	Set screw	1
25	GX10-2	Pin	1
26	GL8-2	Nut	1
27	GR63-2	Cardo	1
	GH6-2	Link	1
28	GS46-2	Screw	1

7. Feed Lifting Mechanism

Ref.Nos.	Parts No.	Description	Quantity
29	GR206-2	Spring washer	1
30	GL8-2	Nut	1
31	GR62-2	Lever	1
32	GS58-2	Screw	2
33	GR205-2	Spring washer	2

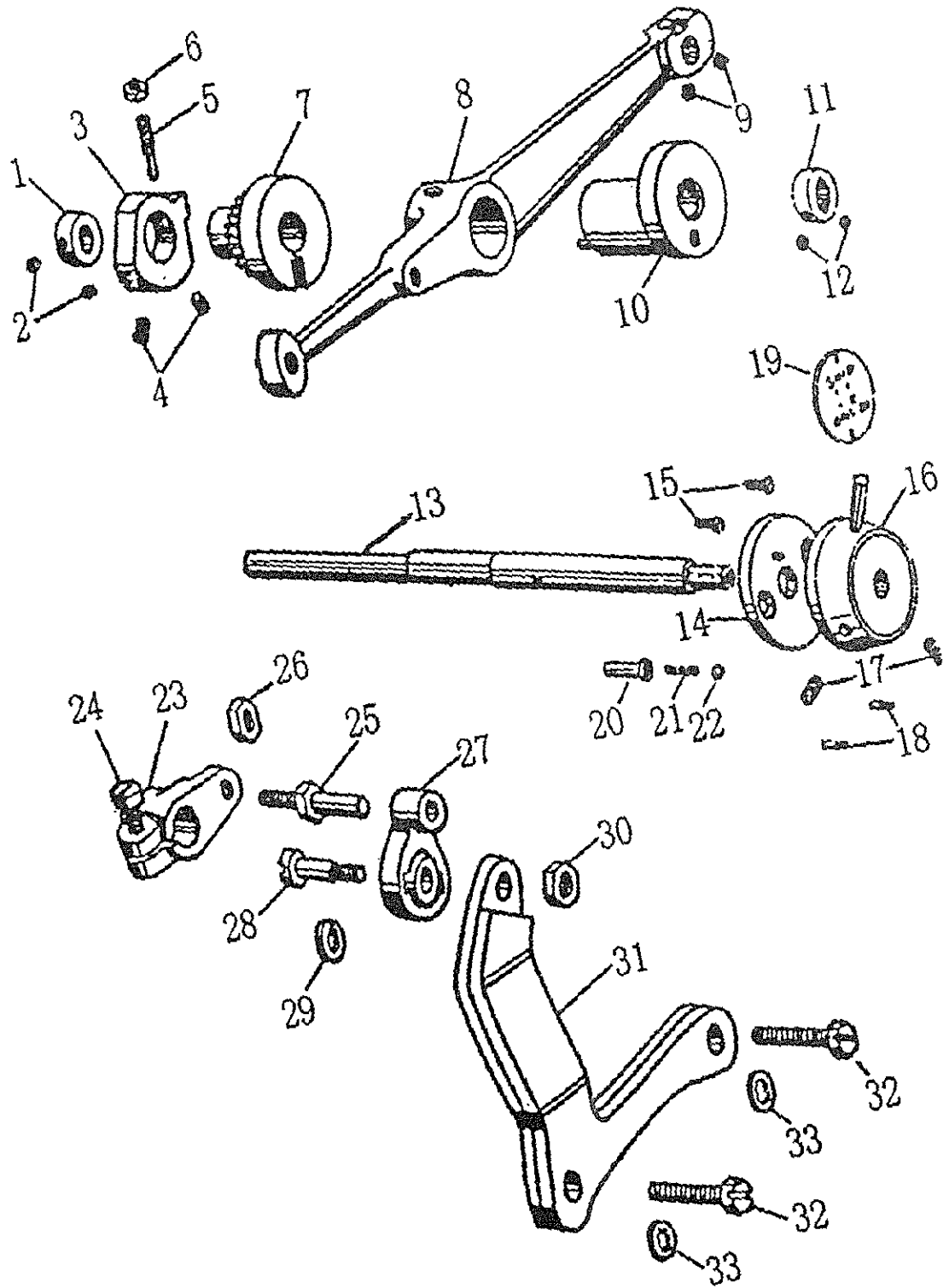

8. Knee Lifter Mechanism

Ref.Nos.	Parts No.	Description	Quantity
1	GR72-2	Stop block	1
2	GS43	Screw	2
3	GW11-2	Spring	1
4	GX12-2	Pin	1
5	GZ17-2	Shaft	1
6	G029-2	Retainer	1
7	GS45	Screw	2
8	GR207-2	Spring washer	1
9	GR76-2	Stop block	1
10	GS43	Screw	2
11	GZ15-2	Segment shaft	1
	GX6-2	Segment gear	1
12	GR70-2	Bearing base	1
13	GS50-2	Screw	2
14	GT2-2	Cam	1
15	GS55-2	Set screw	2
16	GW12-2	Spring	1
17	GX13-2	Pin	1
18	GH9-2	Link	1
19	GS27	Screw	1
20	GR77-2	Roller	1
21	GS53-2	Stud	1
22	GL9-2	Nut	1
23	GH8-2	Connection	1
24	GS05	Screw	1
25	GZ16-2	Bar	1
26	GS52-2	Screw	1
27	GR69-2	Presser block	2
28	GS54-2	Screw	1
29	GR75-2	Stop block	1
30	GS037	Screw	1
31	GS55	Screw	1
32	GH10-2	Connection	1

8. Knee Lifter Mechanism

Ref.Nos.	Parts No.	Description	Quantity
33	GS56-2	Screw	1
34	GS51-2	Screw	1
35	GR74-2	Retainer	1
36	GS05	Screw	1
37	G031-2	Bushing	1
38	GS45	Screw	1
39	GZ18-2	Shaft	1
40	GR71-2	Bushing	1
41	GS49-2	Screw	4
42	GW10-2	Spring	1
43	GX11-2	Pin	1
44	GR73-2	Bushing	1
45	GS48-2	Set screw	1
46	G030-2	Washer	1

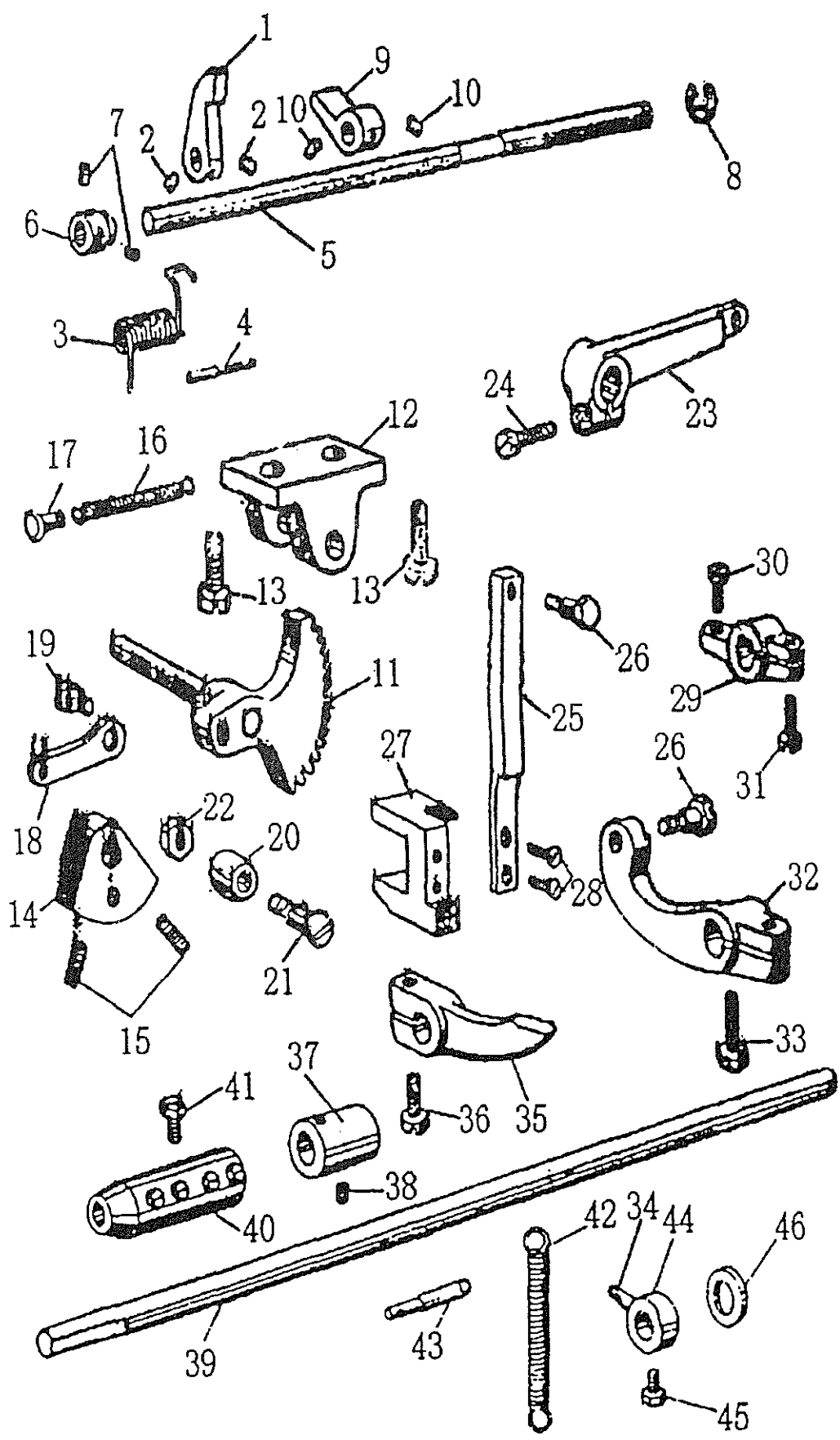

9.Thread Tension Mechanism

Ref.Nos.	Parts No.	Description	Quantity
1	GR12-2	Thread guide	1
2	GS4-2	Screw	1
3	GR13-2	Thread guide	2
4	GS4-2	Screw	2
5	L5	Tension nut	1
6	GW15-2	Tension spring	2
7	R57	Tension releasing disc	1
8	GR013	Thread tension disc	1
9	GX1-2	Pin	1
10	GS3-2	Thread tensions stud	1
11	L1	Nut	1
12	GZ1-2	Prop pin	1
13	GW1-2	Tension releasing spring	1
14	GR2-2	Bushing	1
15	CS48	Set screw	1
16	G02-2	Eccentric bushing	2
17	S18	Set screw	

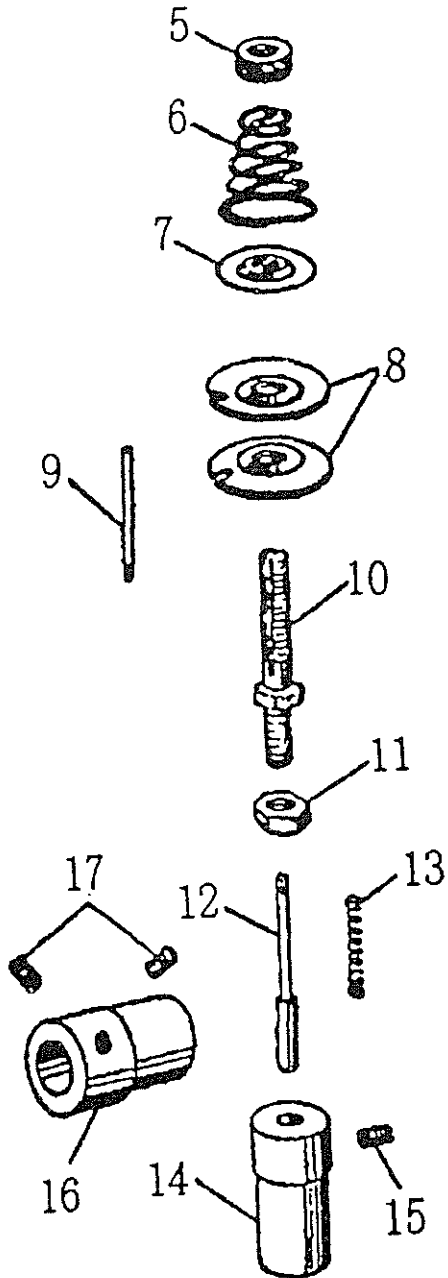
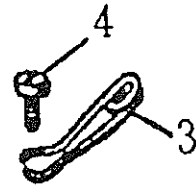
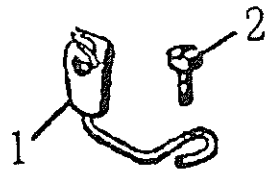

10. Cloth Plate Assy.

Ref.Nos.	Parts No.	Description	Quantity
1	GR80-2	Cloth plate	1
2	GX15-2	Pin	1
3	GS49-2	Screw	1
4	GZ20-2	Stud	1
5	GS104-2	Screw	1
6	G032-2	Spacer	1
7	S18	Screw	1
8	GS58-2	Screw	2
9	GR78-2	Support base	2
10	GS105-2	Screw	1
11	GX14-2	Pin	2
12	GW14-2	Spring plate (long)	1
13	GW13-2	Spring plate (short)	1
14	GS49-2	Screw	1
15	GZ19-2	Knee lifting bar	1
16	GR83-2	Pad	1
17	GS49-2	Screw	1
18	GR84-2	Cushion	1

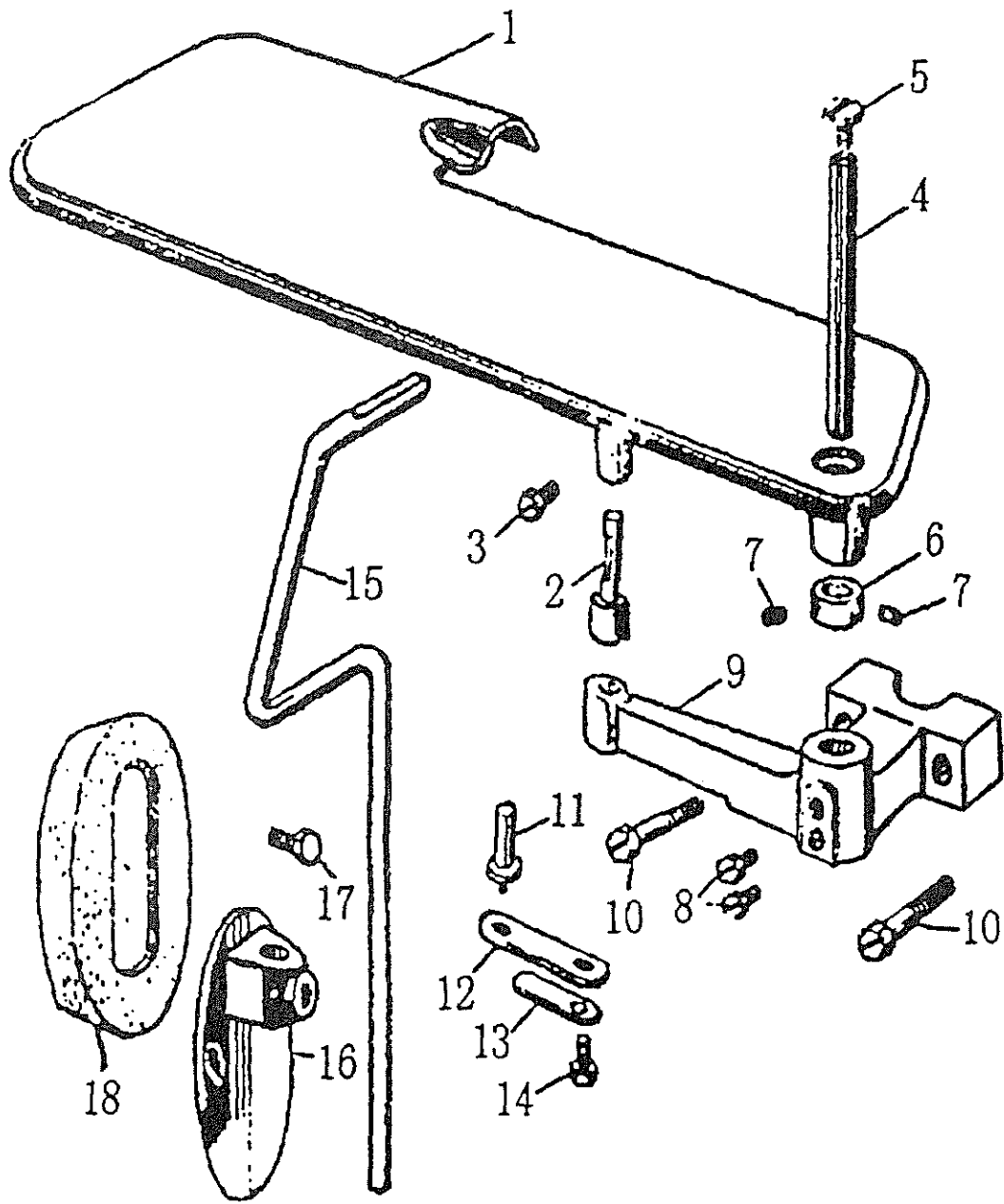

SHANGHAI HUIGONG NO.3 SEWING MACHINE FACTORY

ADD: 1418, Yishan Road, Shanghai, China

Zip Code: 201103

Overseas Business: TEL: 86-21-64853303 FAX: 86-21-64854304

E-mail: highlead@online.sh.cn <http://www.highlead.com.cn>