

Purchasing Dept  
Copy

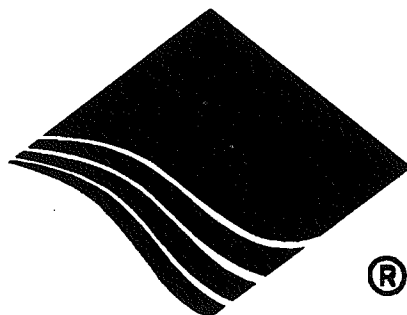

**HIGHLEAD**

**GK500 SERIES**

**High-speed Stretch Sewing Machine**

**Instruction Manual**  
**Parts Catalog**

**SHANGHAI HUIGONG NO.3 SEWING MACHINE FACTORY**



# — INTRODUCTION —

Thank you very much for purchasing 500 Series machine.

This instruction manual describes daily routine maintenance and safety precautions to keep the machine in the best possible conditions.

Please study this manual very carefully before operating the machine.



## CAUTION

### OBSERVE THESE SAFETY PRECAUTIONS

Though Pegasus takes the utmost care to produce safe sewing machines and devices, operators should follow these basic safety rules.

- To prevent accidents, do not remove safety devices or parts while operating the machine.
- Do not leave tools or other unnecessary objects on the machine table while operating the machine.
- Before maintenance, adjusting, cleaning, threading or replacing the needle, and to prevent accidents, be sure the power is turned off. Check that the machine will not operate when the pedal is pressed.



## NOTE

In case a crutch type motor is used, it will keep on rotating by inertia after turning off power supply

①. If the machine pedal ② is stepped on inadvertently, it is dangerous because the machine will move unexpectedly. Keep on stepping on the machine pedal ② until the machine comes to a stop after turning off power supply ①.

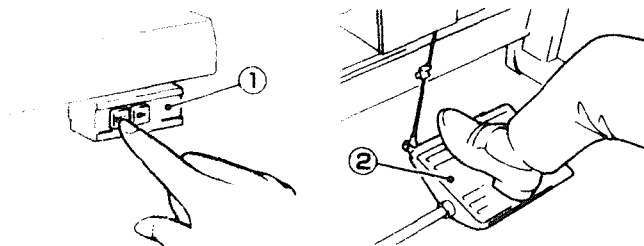

- Turn the power off before leaving the machine table.
- In the event of a power failure, be sure to turn the machine off.
- Check that the machine is securely grounded.



■ **BEFORE OPERATING**

1. Lubrication ..... 1  
2. Manual lubrication ..... 2  
3. Filling the HR device with silicon oil ..... 3  
4. Threading ..... 4  
5. Threading diagram (2-needle, 3-needle, 4-needle) ..... 5

■ **TEST SEWING**

1. Adjusting the presser foot pressure ..... 6  
2. Adjusting the diff. feed ratio ..... 7  
3. Adjusting the stitch length ..... 8  
4. Adjusting the thread tension ..... 9

■ **MAINTENANCE DURING USE**

1. Cleaning the machine ..... 10  
2. Replacing the needle ..... 11  
3. Checking the oil circulation ..... 12  
4. Checking and replacing the oil filter ..... 13  
5. Replacing the oil ..... 14  
6. Adjusting Dimensions ..... 15

■ **PARTS CATALOG**

..... 16-24

■ **GAUGE PARTS LIST**

..... 25-28



## ■ BEFORE OPERATING

### Lubrication

After filling the oil pan, the oil surface should lie between (H) and (L) lines.

Add oil when the oil surface reaches or goes below (L).

Note : Use recommended oil (HIGH SPEED SEWING MACHINE OIL) (ISO VG22)

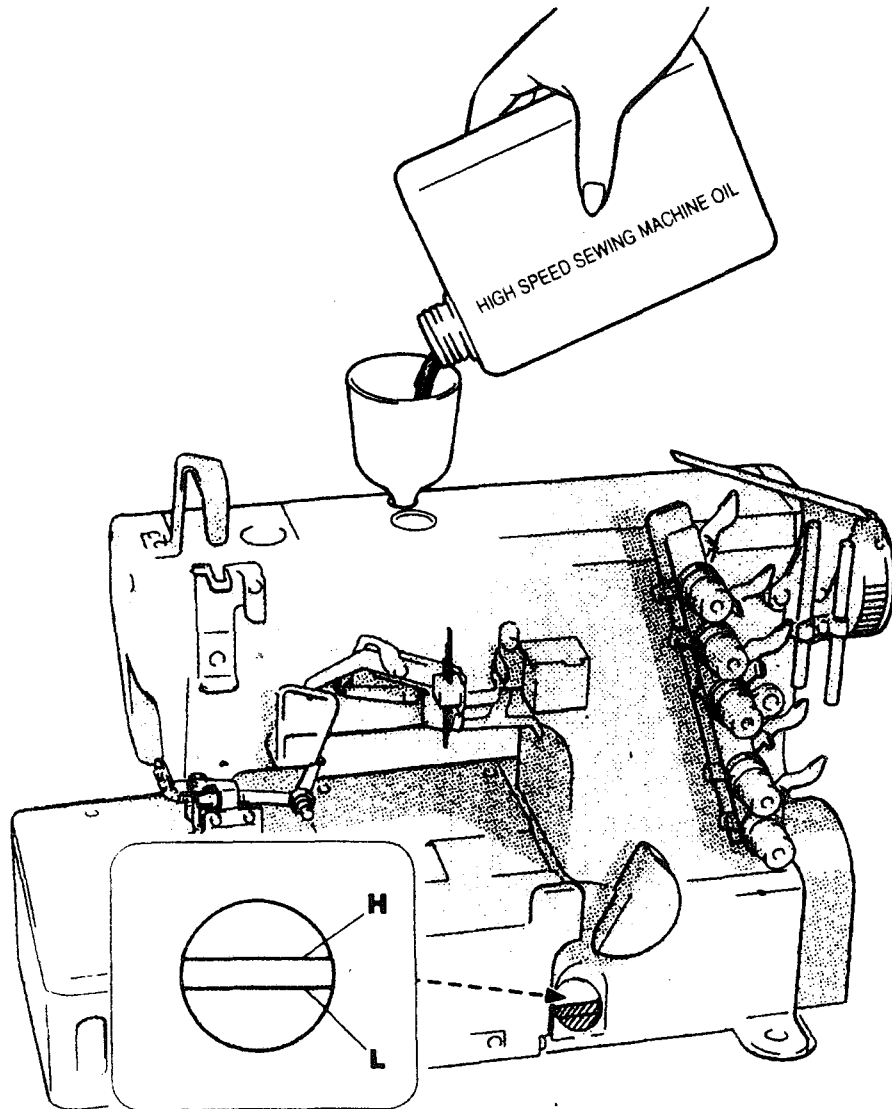

## ■ BEFORE OPERATING

### Manual lubrication

Apply 2 or 3 drops of oil by hand when the machine is used for the first time or has been left unused for some time.

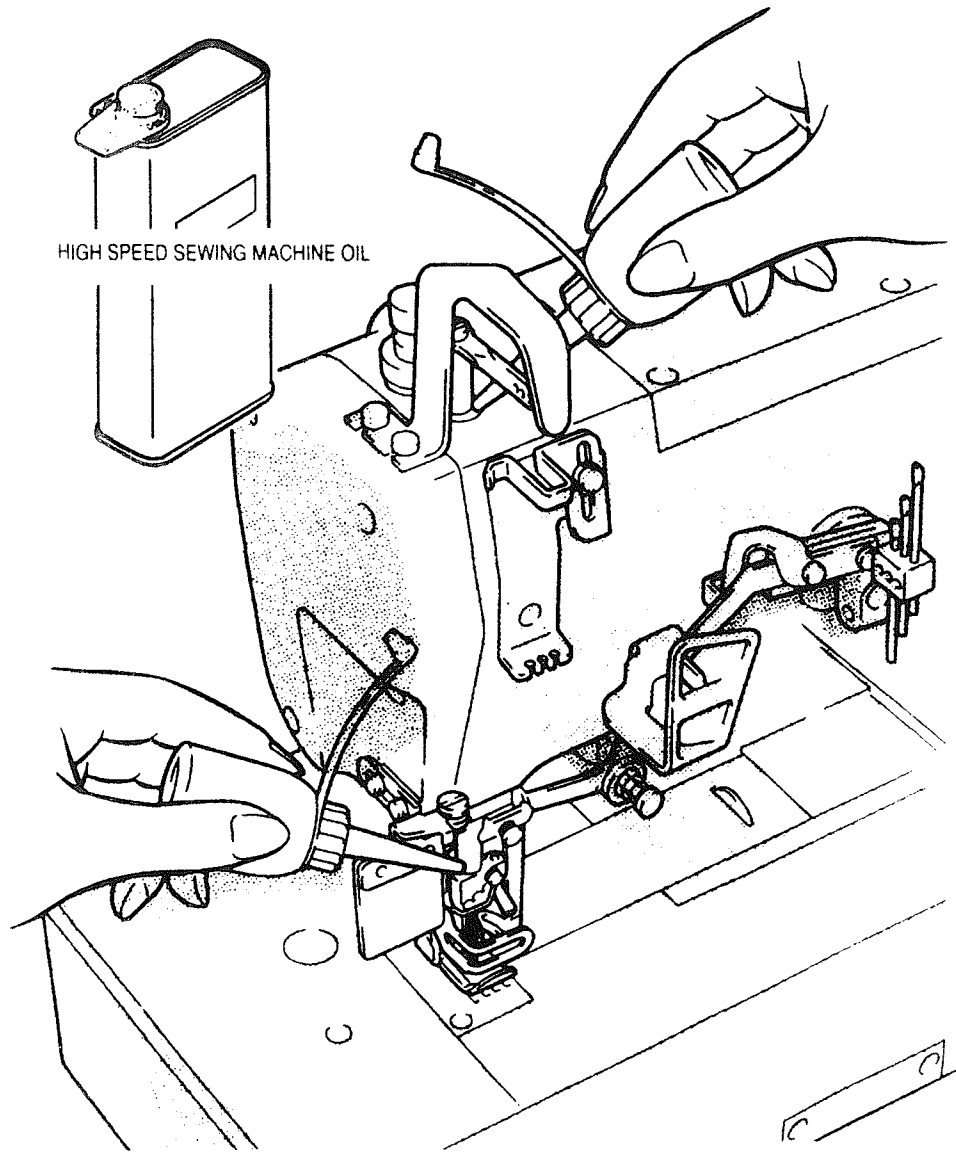



---

■ **BEFORE OPERATING**

Filling the HR device with silicon oil

Fill the HR device with oil before it is too low in order to prevent needle thread breakage and fabric damage.

Note : Use LAKE recommended silicon oil. (UNION CORPORATION) UCCL-45 (350)

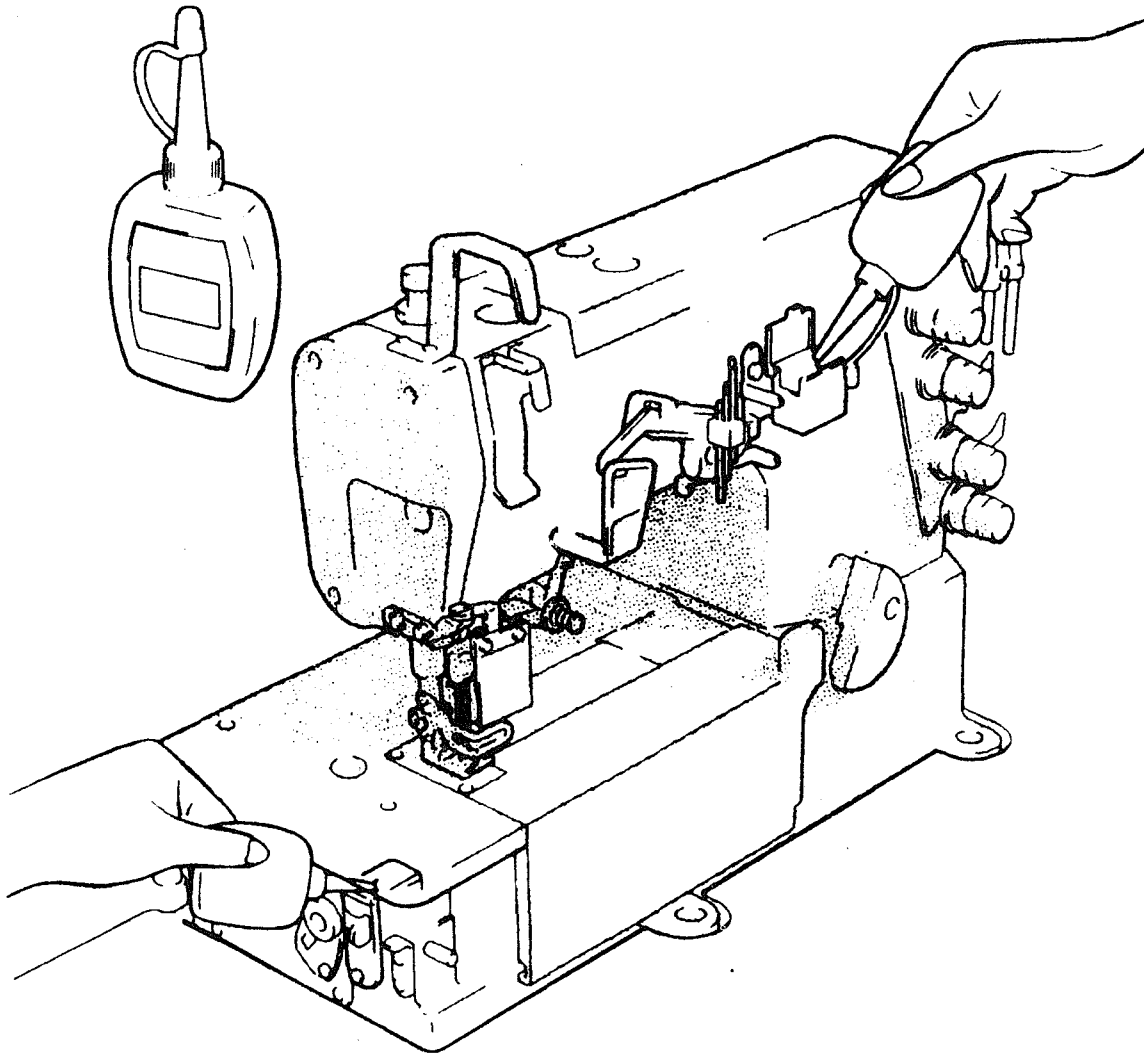

# BEFORE OPERATING

## Threading

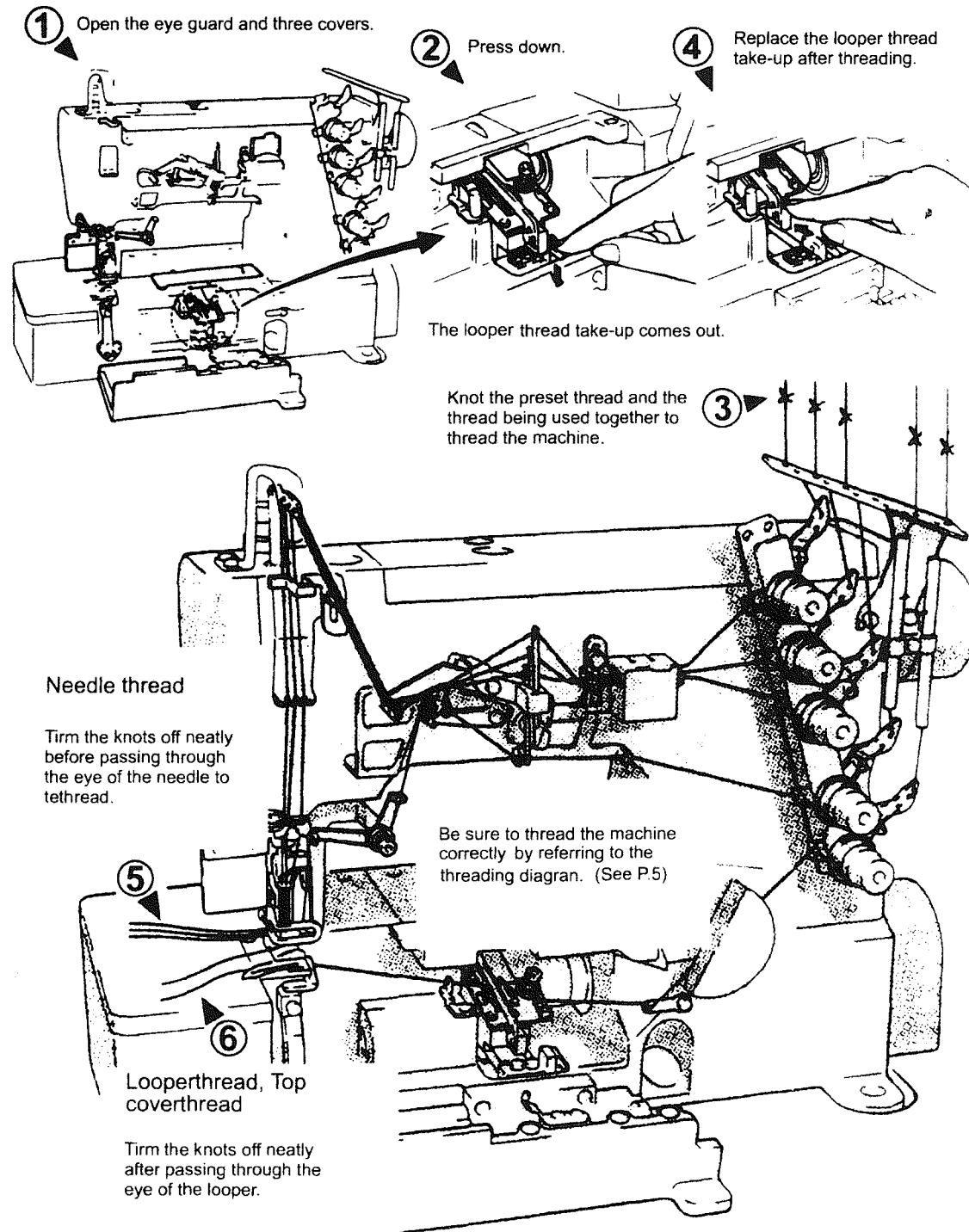

# BEFORE OPERATING

## Threading diagram (2-needle, 3-needle, 4-needle)

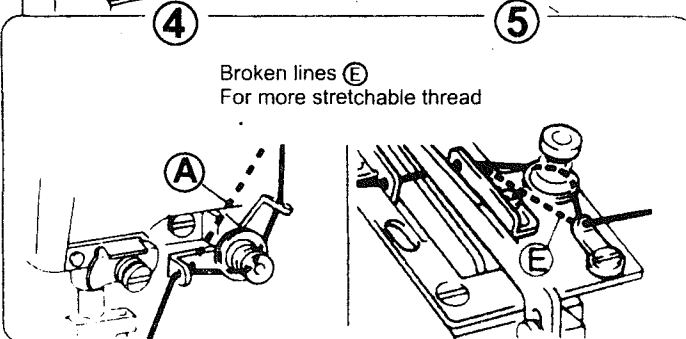
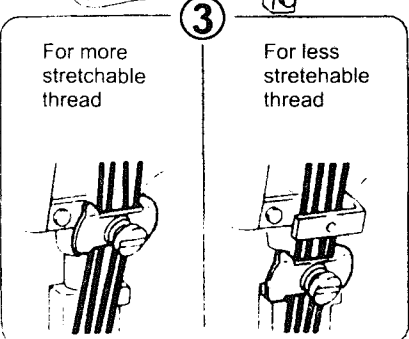
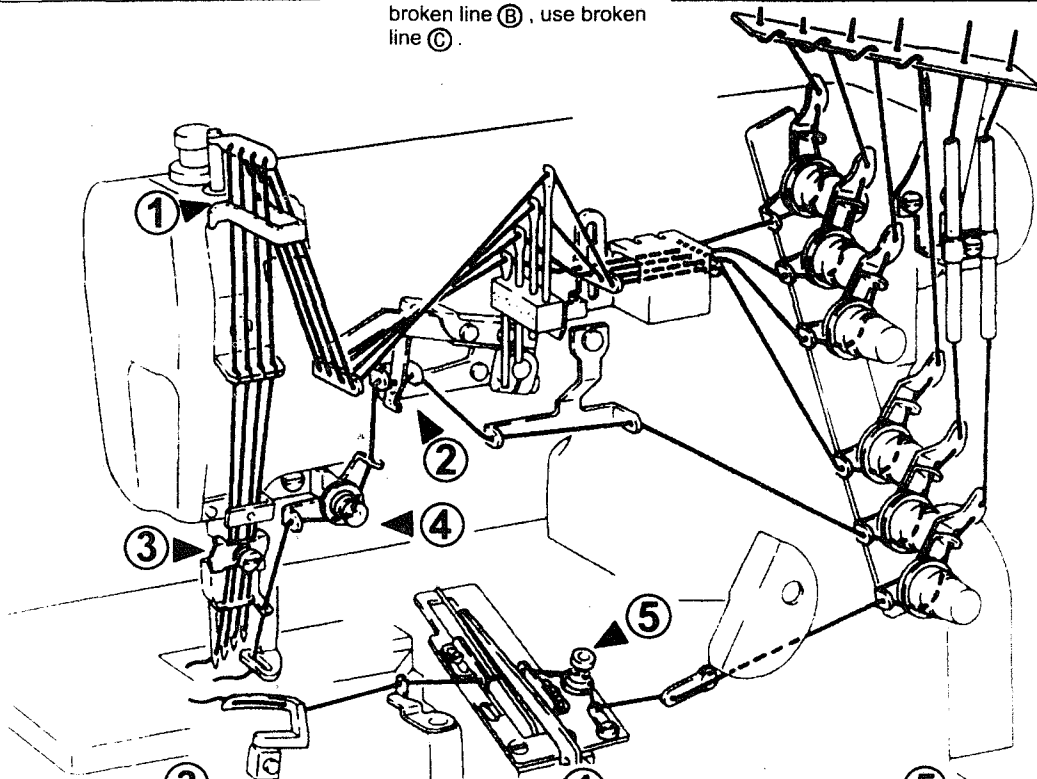
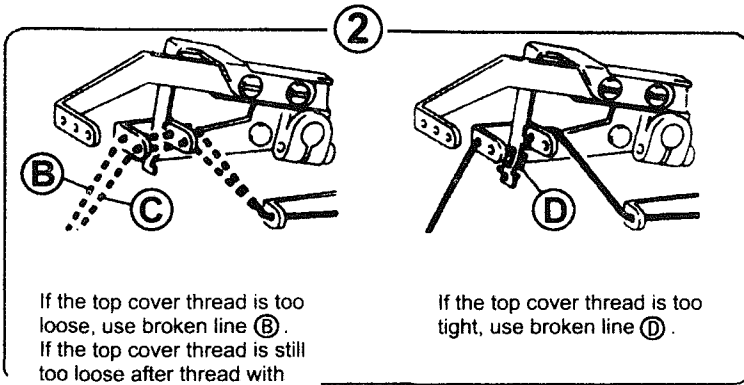
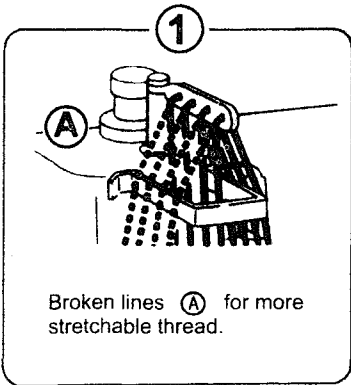

From the library of: Diamond Needle Corp

## ■ TEST SEWING

### Adjusting the presser foot pressure

Loosen adjusting nut ① and turn adjusting screw ② to adjust the presser foot pressure. It should be as light as possible, yet be sufficient to obtain the proper stitch formation.

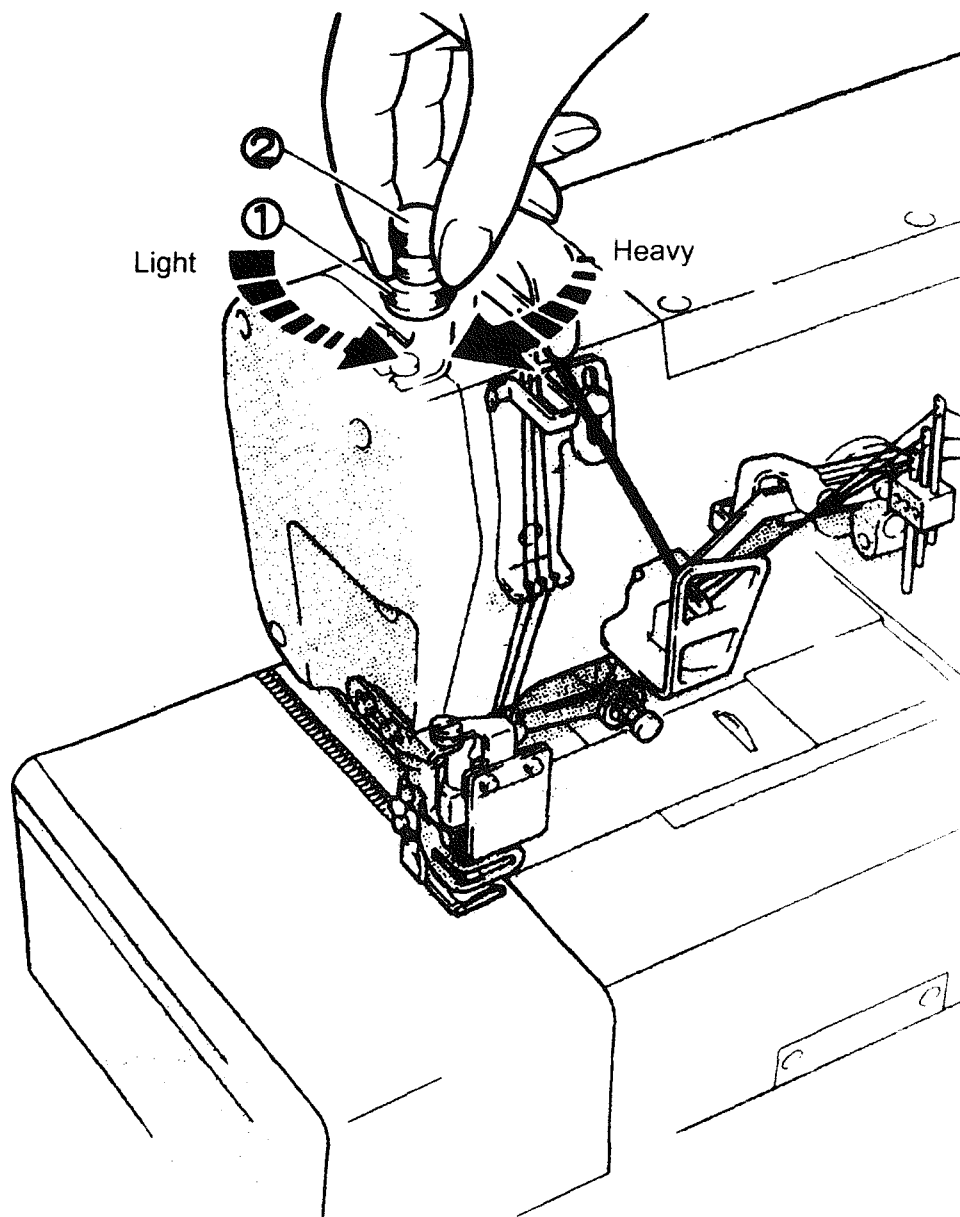

## ■ TEST SEWING

### Adjusting the diff. feed ratio

Loosen nut ① and move the lever up ② and down to obtain the correct differential feed ratio, then tighten nut ①.

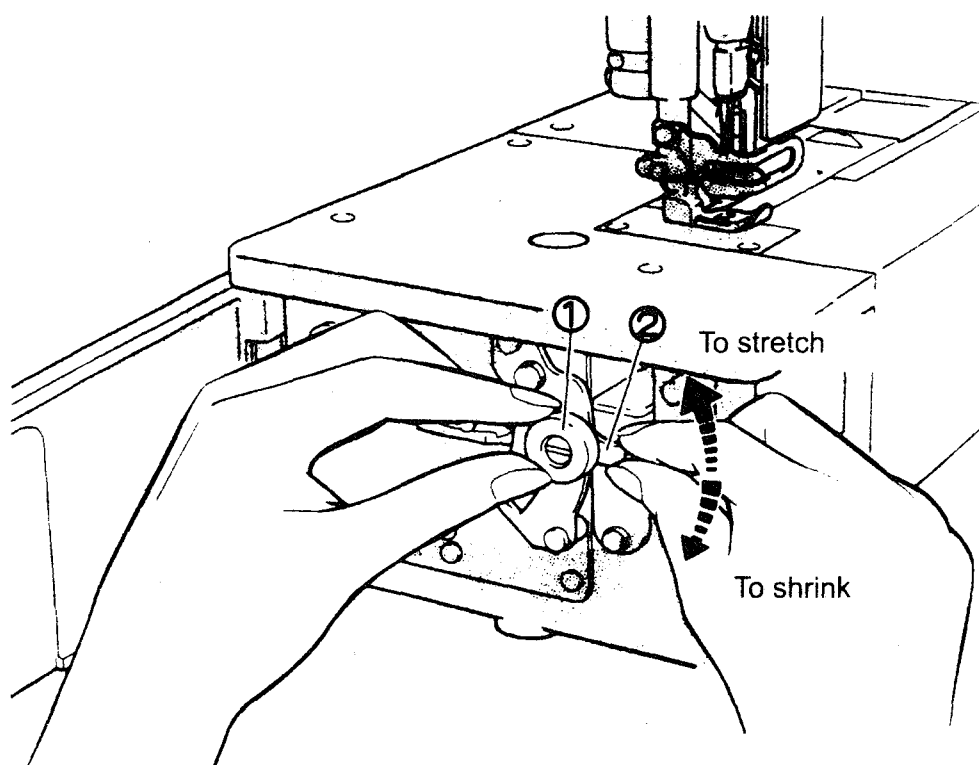

## ■ TEST SEWING

### Adjusting the stitch length

While pressing the push button, turn the hand wheel to seek the position at which the push button goes further into the depth.

Then keeping the push button pressed, turn the hand wheel and set the desired scale to the aligning mark.

Note : Stitch length adjustment must only be made after the differential feed ratio has been changed.

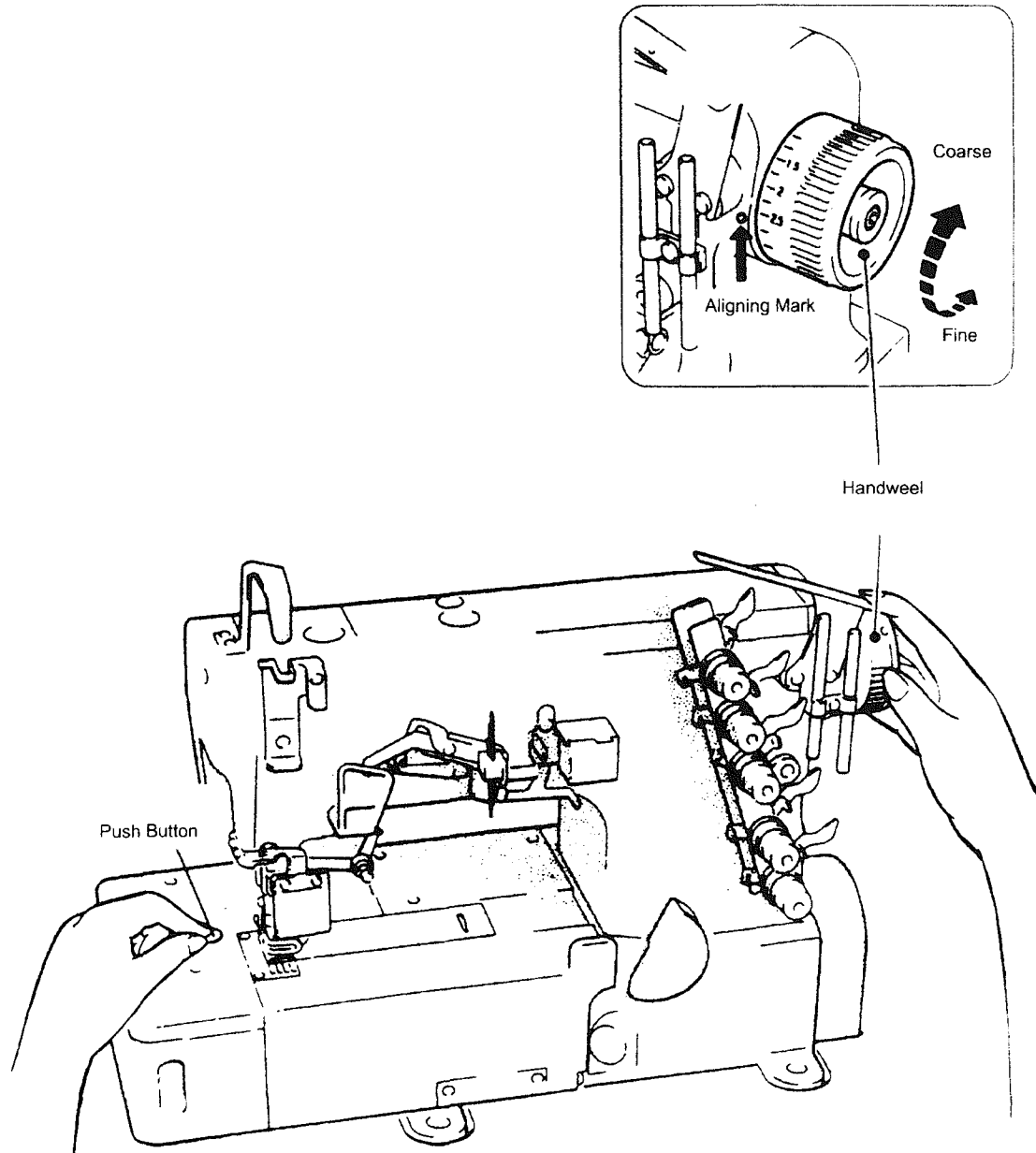

## ■ TEST SEWING

### Adjusting the thread tension

Make tension adjustments with the needle thread knob ①, top cover thread knob ② and the lower looper knob ③.

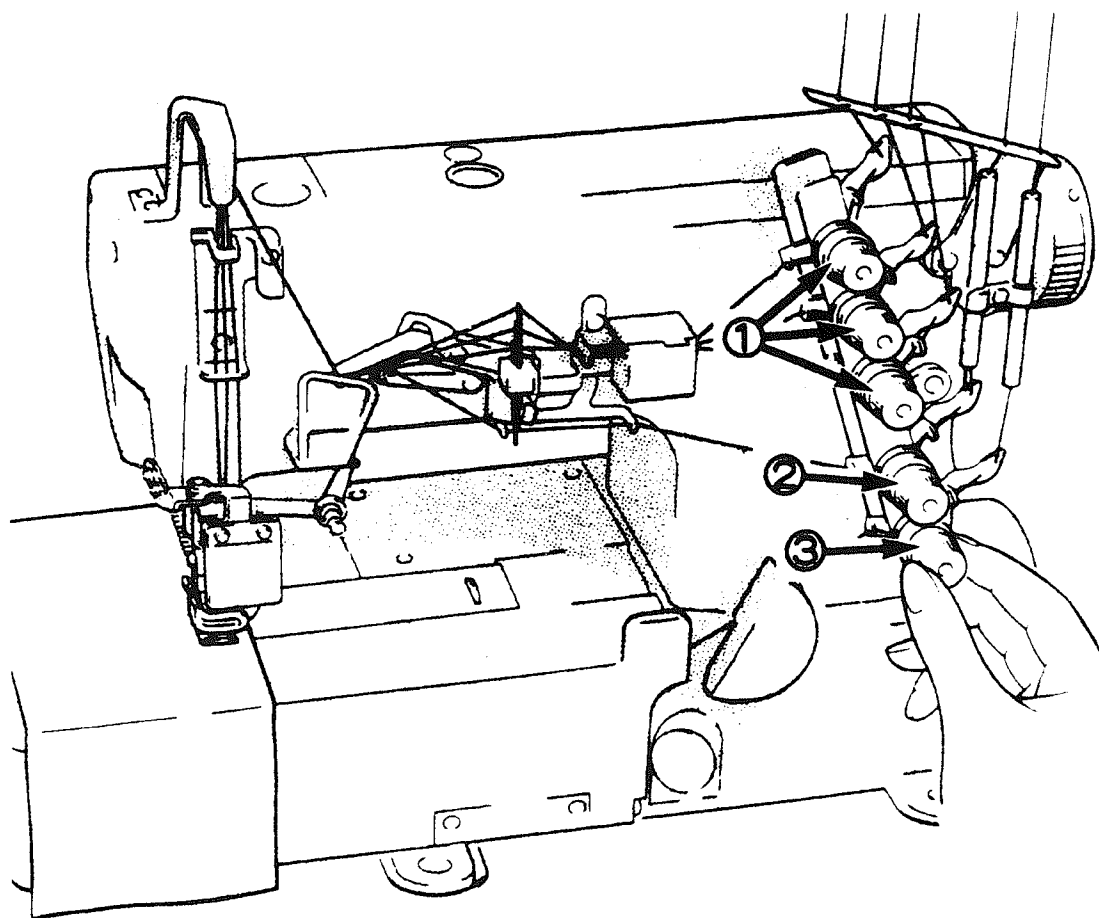
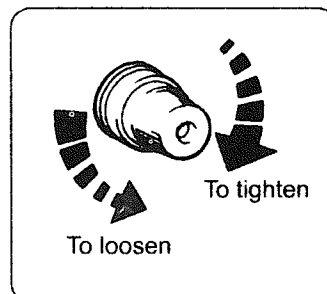

## ■ MAINTENANCE DURING USE

### Cleaning the machine

Mainly the slots of the needle plate and the feed rows should be cleaned.

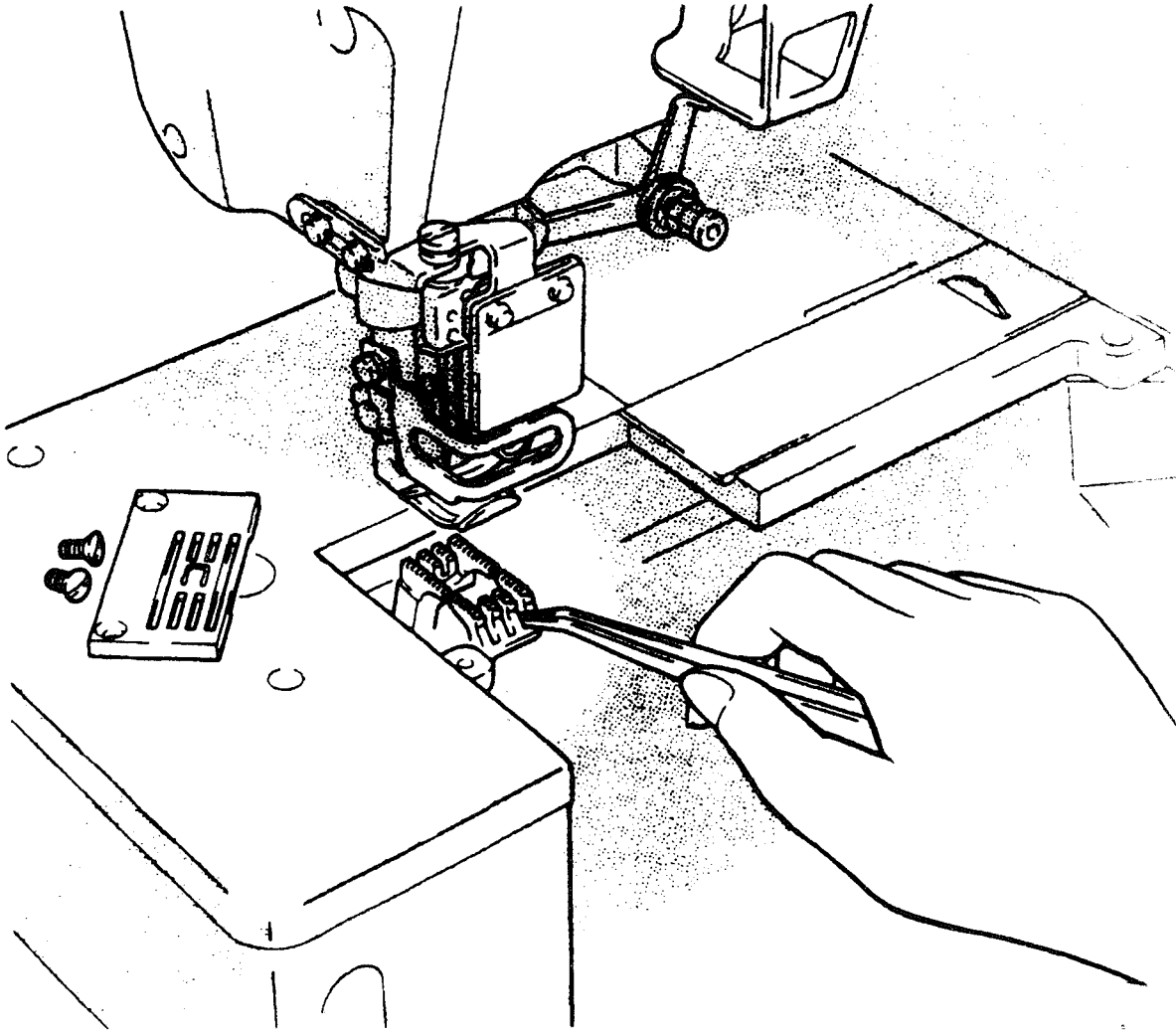



## ■ MAINTENANCE DURING USE

### Replacing the needle

Check the needle carefully to see that the start is turned to the rear of the machine.  
Insert the needle to the proper depth, and fasten securely.

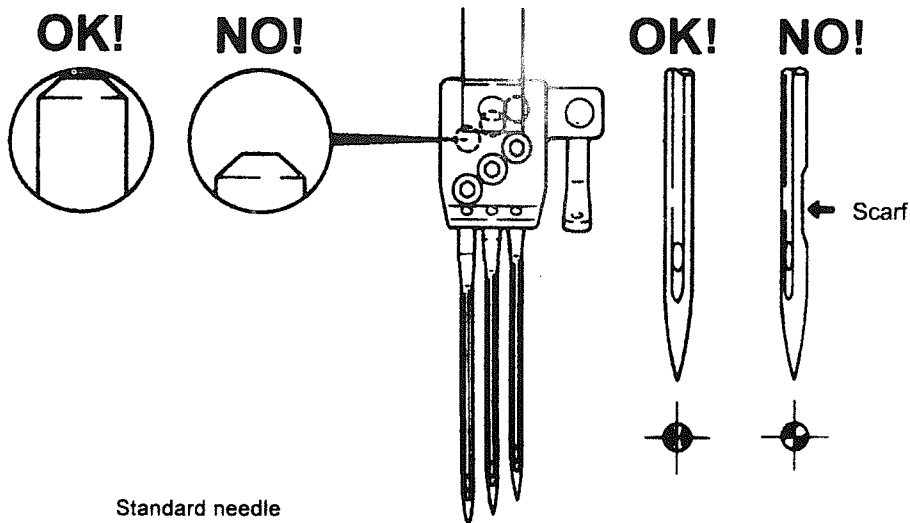

Standard needle

		NEEDLE SIZE	
		2-needle	3-needle
Organ	UY128GAS	# 9	# 10
Schmetz	UY128GAS		

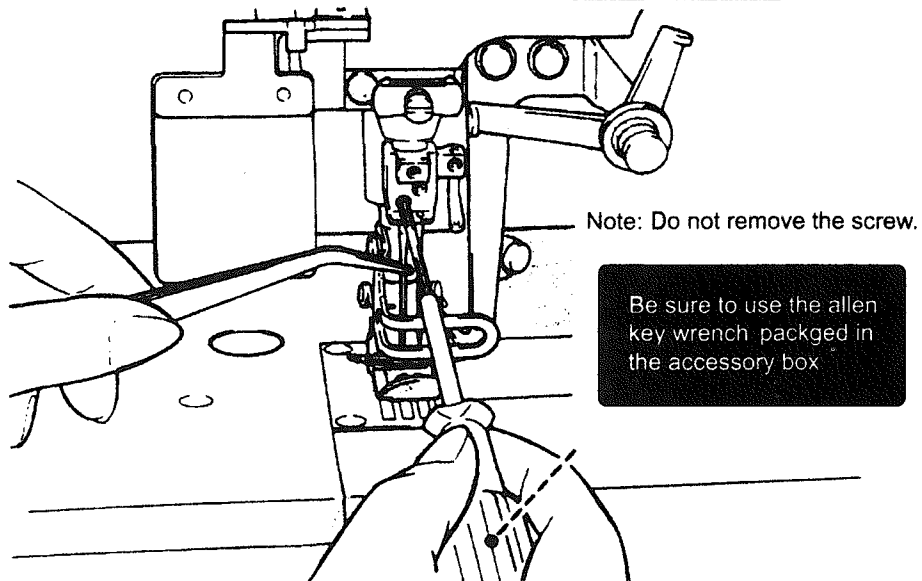

■ MAINTENANCE DURING USE

Checking the oil circulation

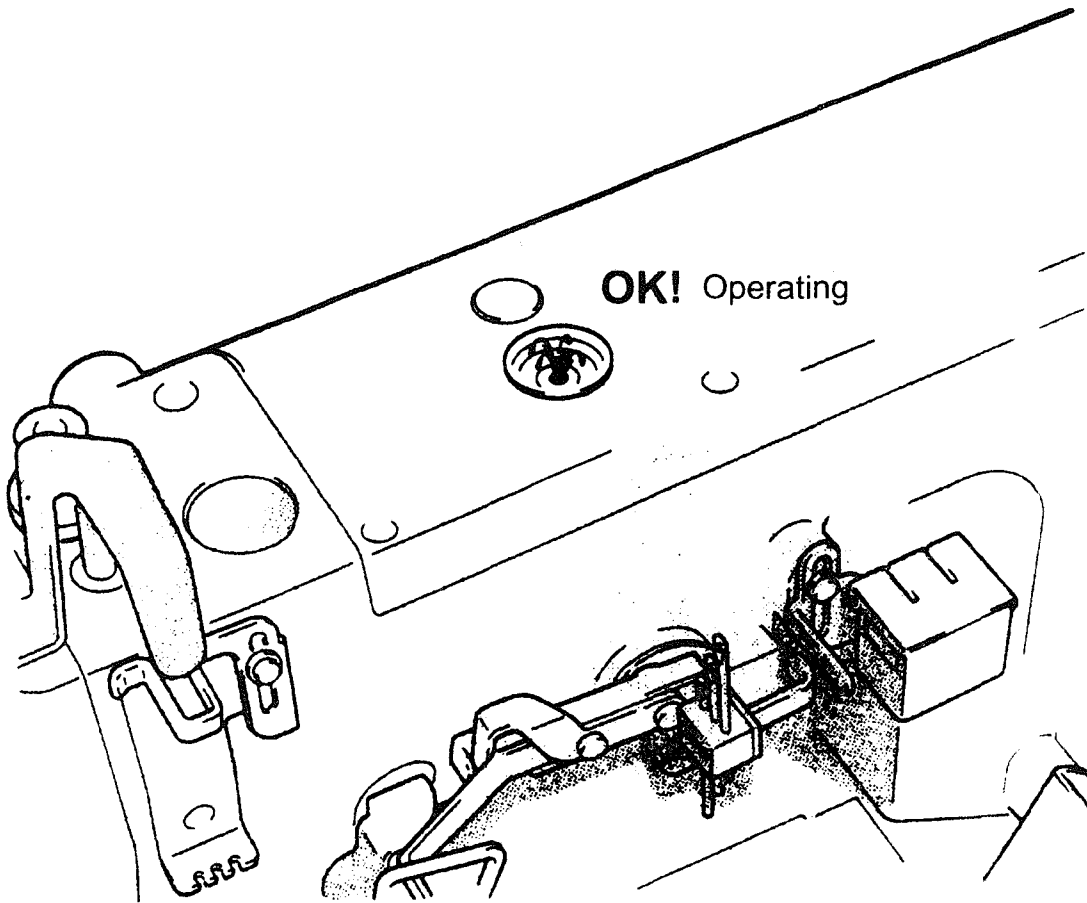

---

## ■ MAINTENANCE DURING USE

### Checking and replacing the oil filter

Check and replace the oil filter every six months.

Note : On machines fit with a UT Device, remove the solenoid bracket.

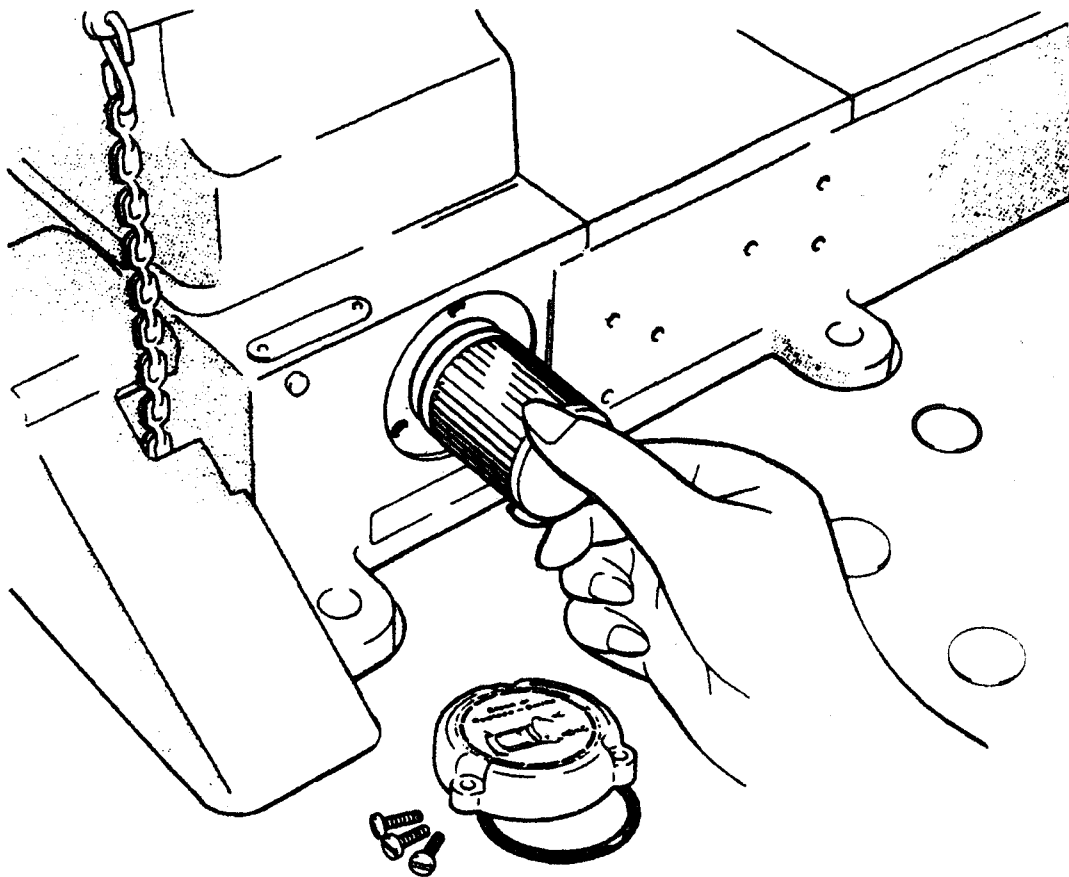

---

■ MAINTENANCE DURING USE

Replacing the oil

Replace the oil one month after the first use and every six months thereafter.

See P.1

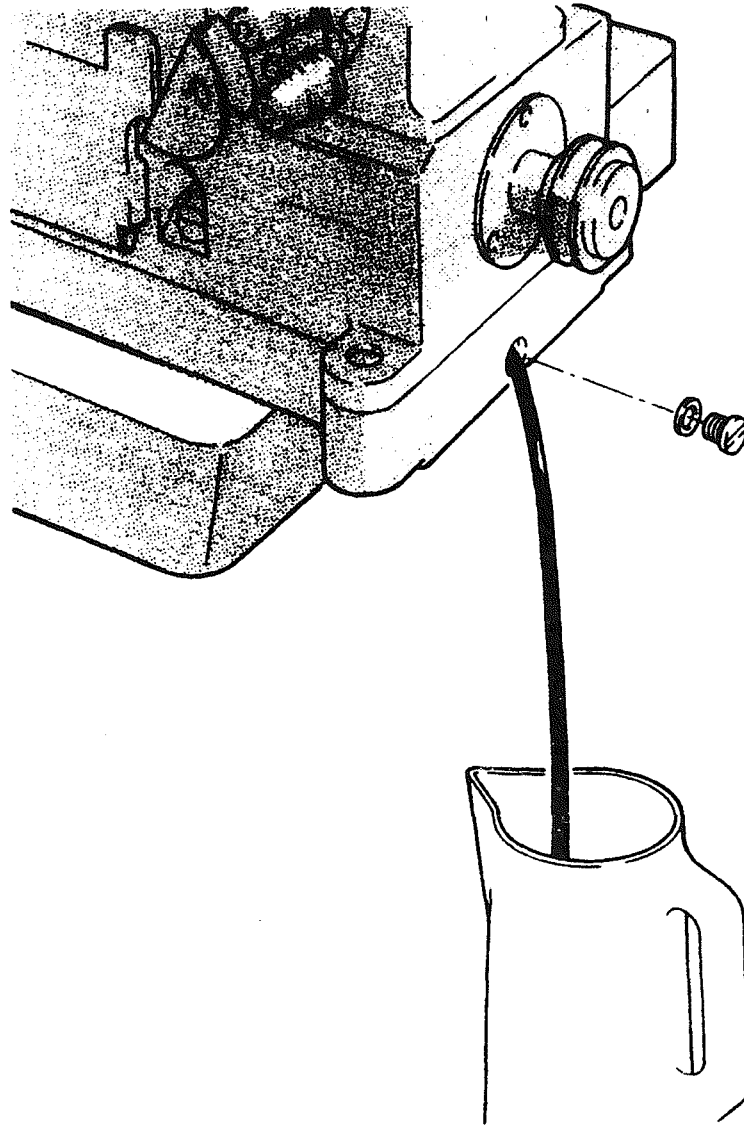

500 Adjusting Dimensions

(mm)

500-01CB	224	10.2	4.8~5.1	8.3~8.7	4.5~5.0	17.0	0.8~1.2		From the library of: Diamond Needle Corp
02BB	232	9.8	4.4~4.7	8.3~8.7	4.5~5.0	17.0	0.8~1.2		
03EB	248	8.9	3.6~3.9	8.3~8.7	4.5~5.0	17.0	0.8~1.2		
04DB	256	8.5	3.2~3.5	8.3~8.7	4.5~5.0	17.0	0.8~1.2		
05MD	264	8.1	2.8~3.1	8.3~8.7	4.5~5.0	17.0	0.8~1.2		
06HD	348	9.4	3.6~3.9	8.3~8.7	4.5~5.0	17.0	0.8~1.2		
07FD	356	8.5	8.3~8.7	8.3~8.7	4.5~5.0	17.0	0.8~1.2		
08AB	364	8.1	2.8~3.1	8.3~8.7	4.5~5.0	17.0	0.8~1.2		

### 1 Frane assembly

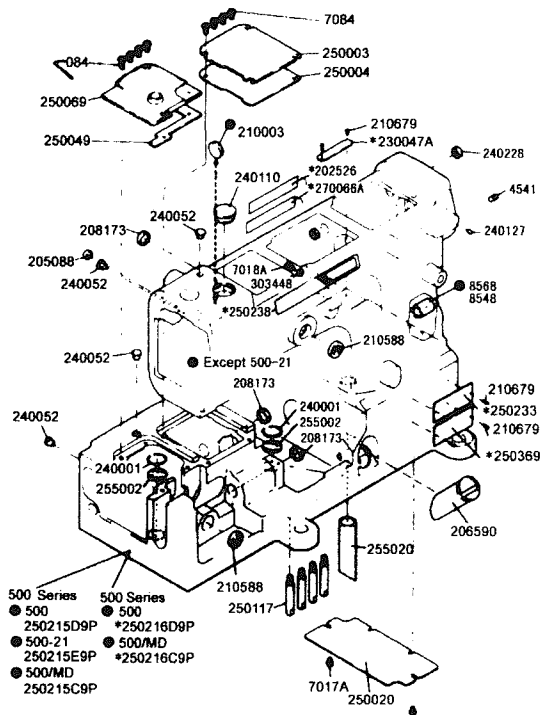

### 2 Cover assemblies

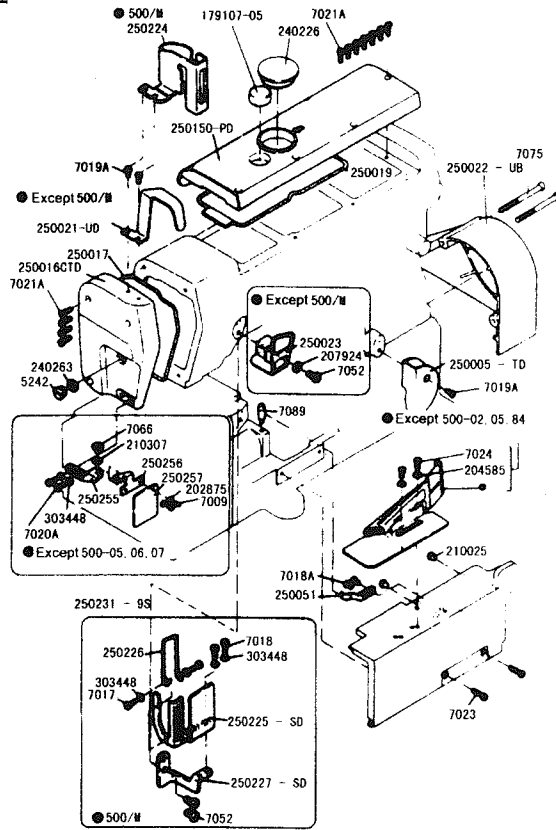

### 3 Cloth plate assemblies

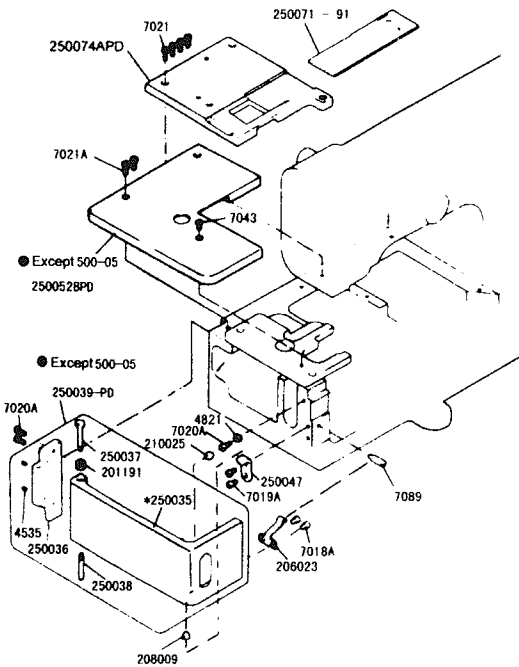

### 4 Hook shaft assemblies

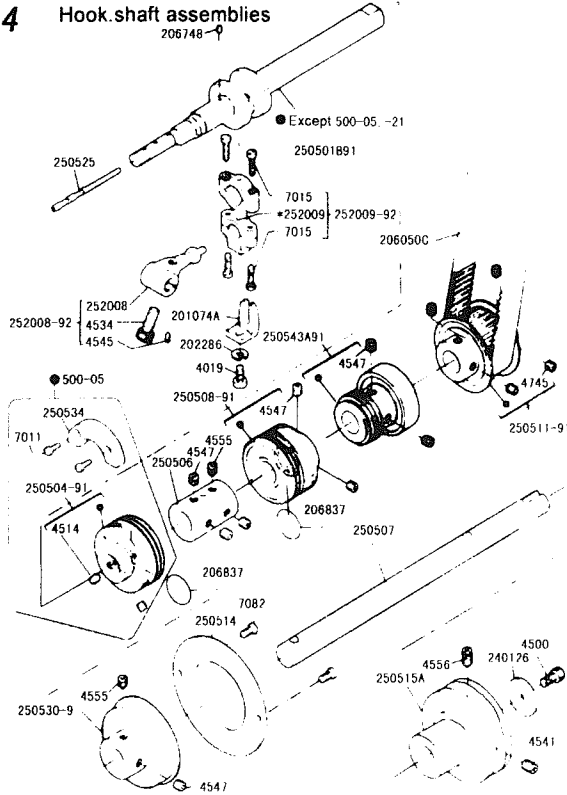

**5 Main shaft assemblies**

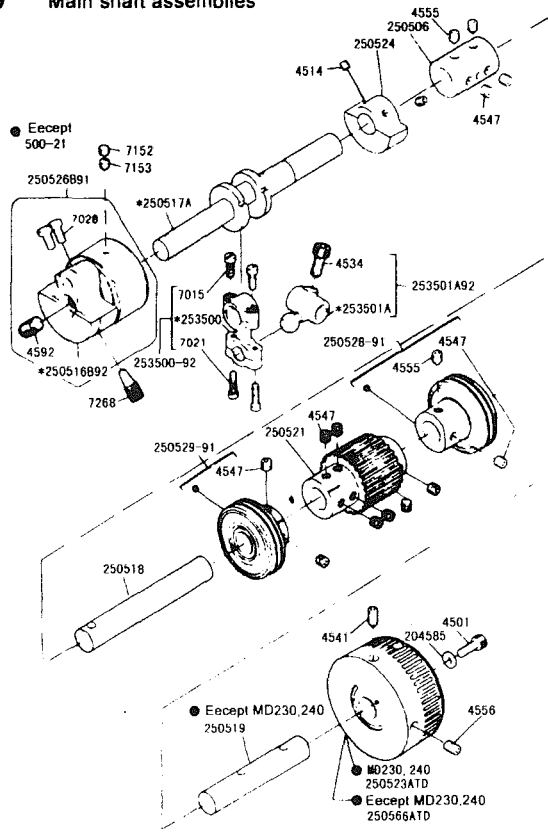

**6 Please confirm the correct part by the gauge parts lists. Needle bar assemblies**

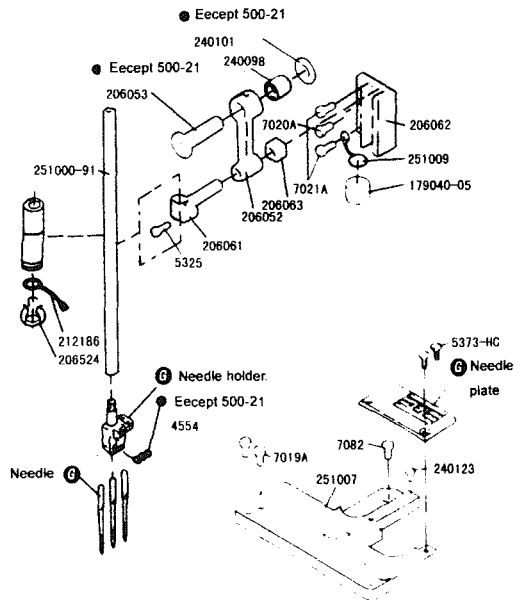

**7 Please confirm the correct part by the gauge parts lists. Needle guard assemblies**

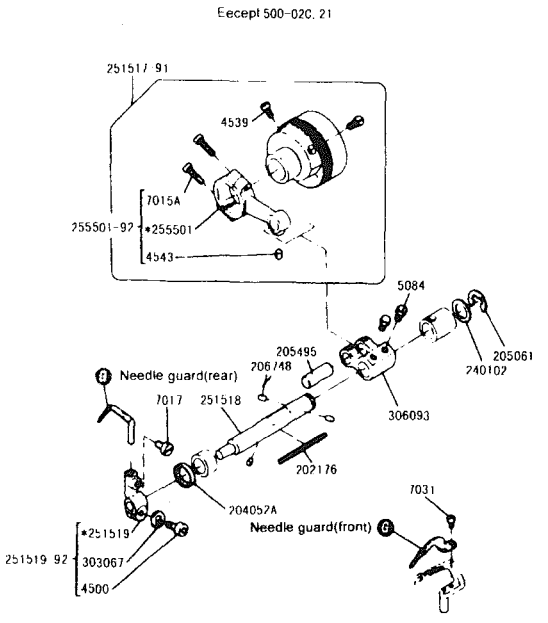

**8 Loper assemblies**

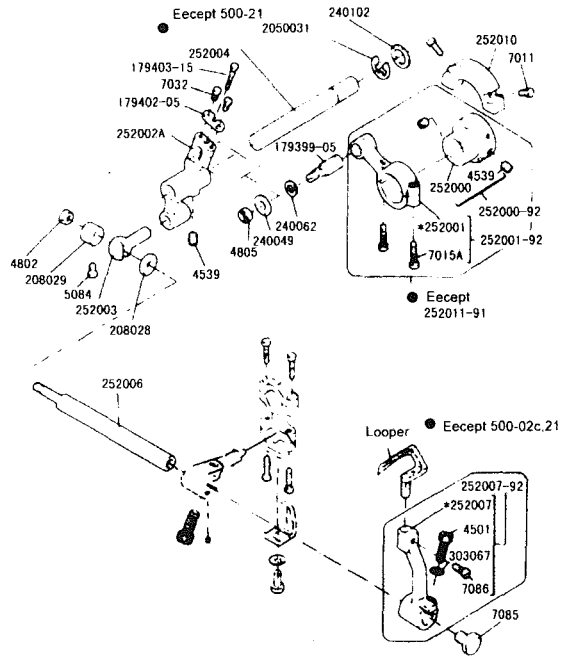

From the library of: Diamond Needle Corp

9 Please confirm the correct part by the gauge parts lists. 10 Differential assemblies

Feed dog holder assemblies

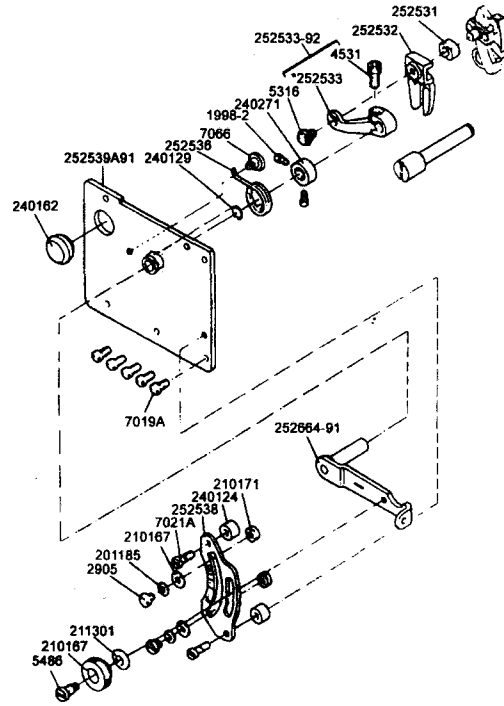
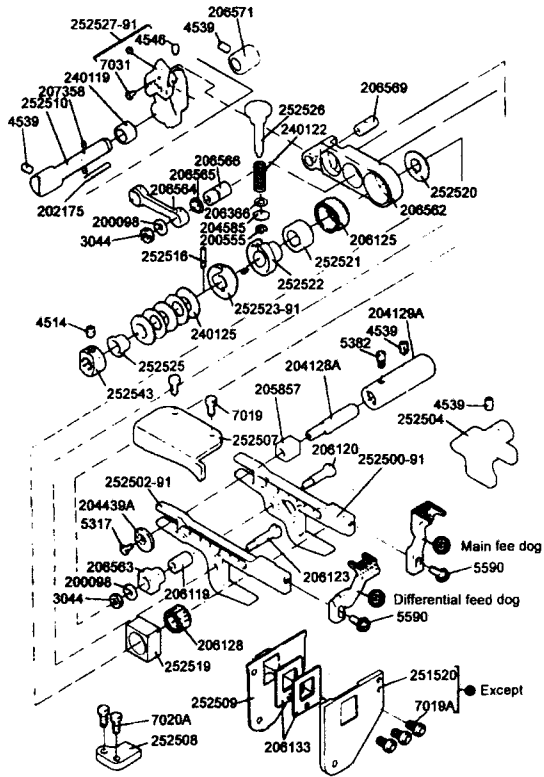

11 Please confirm the correct part by the gauge parts lists. 12 Needle feeding assemblies

Presser form assemblies

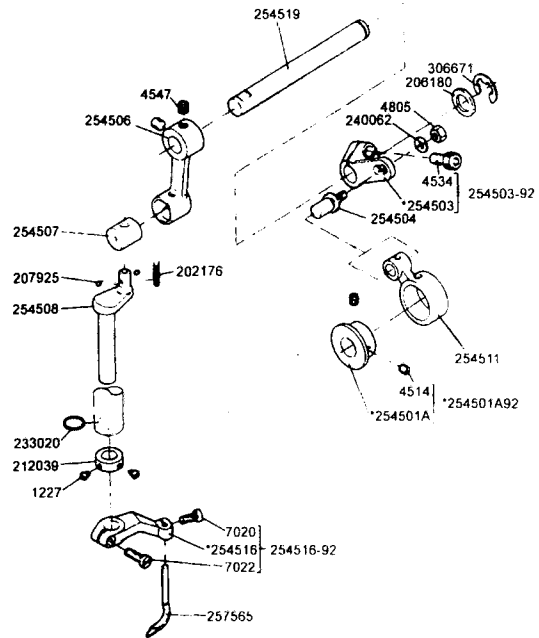
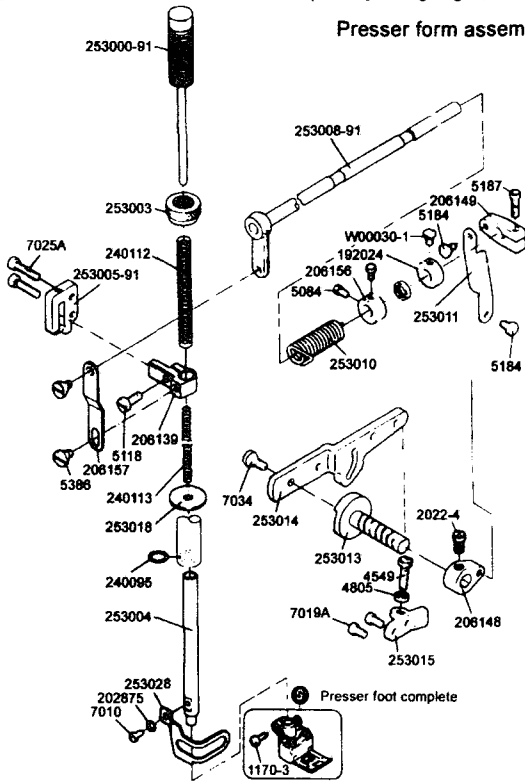

\* = ( not for sale )



### 13 Thread loosing assemblies

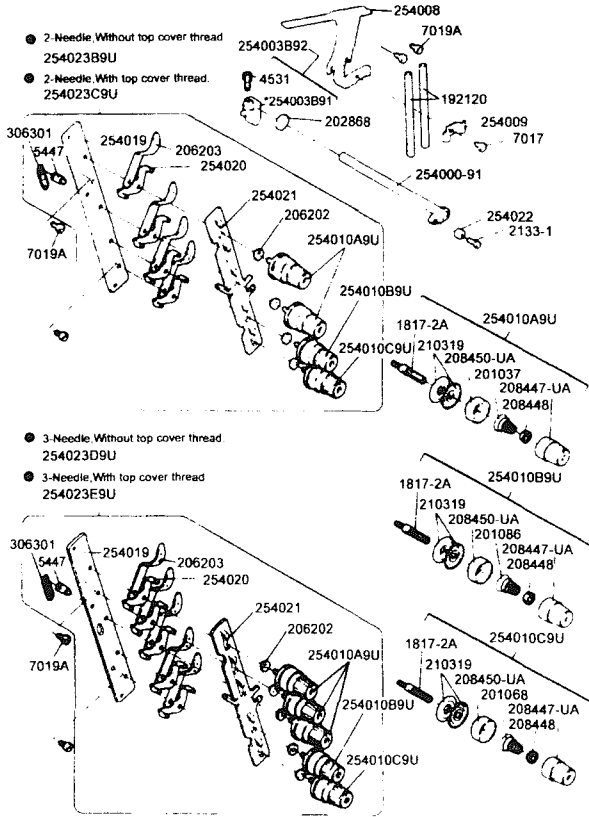

### 14 Thread guide assemblies

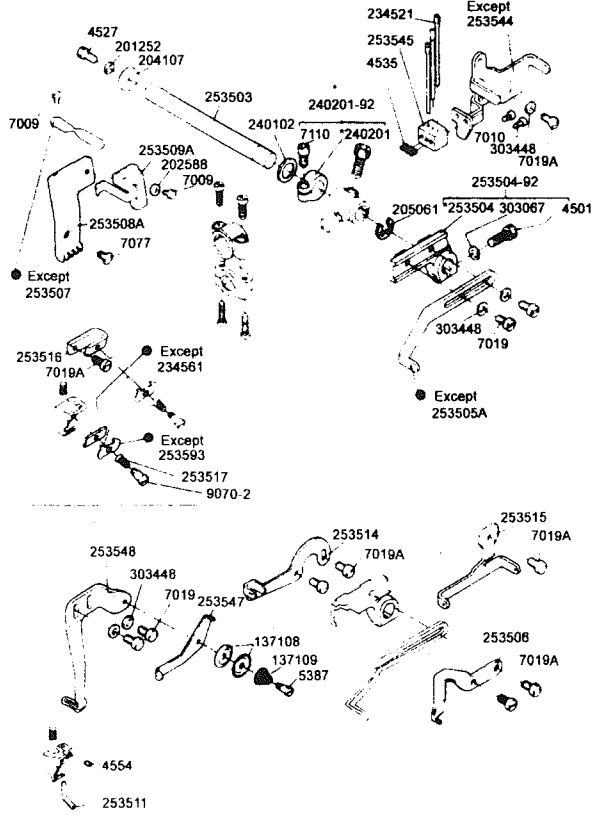

### 15 Cam assemblies

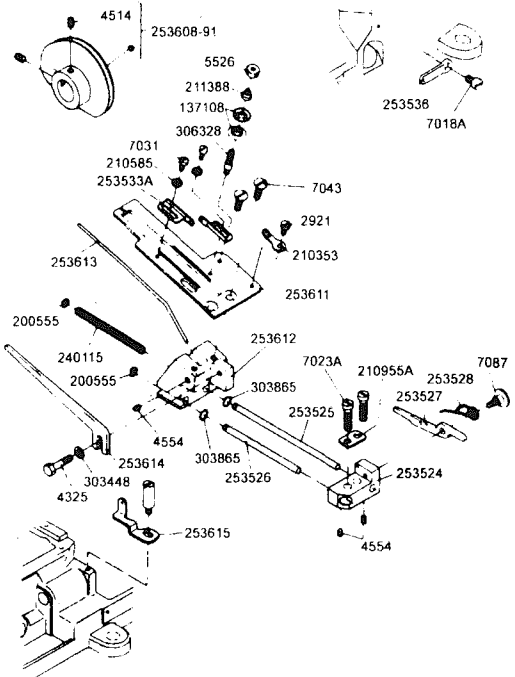

### 16 Lubrication assemblies

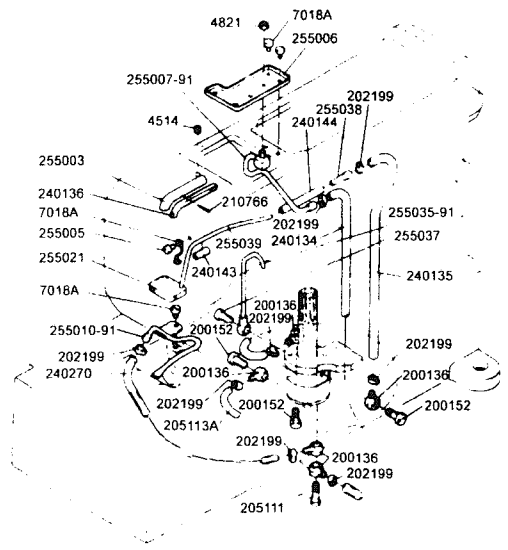

From the library of: Diamond Needle Corp

17 Oil pump assemblies

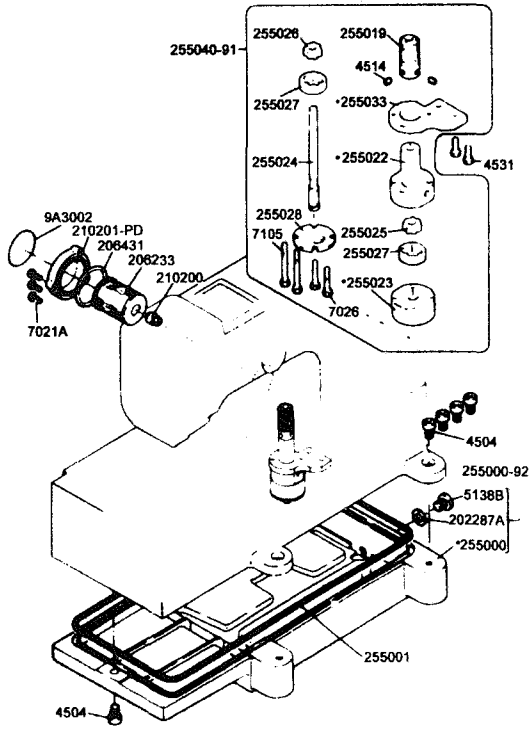

18 Silicon oil delice assemblies

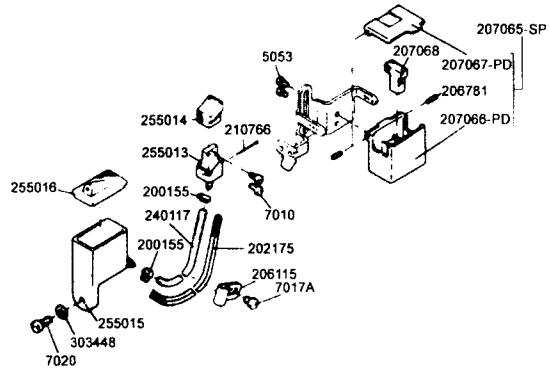

19 Thread spool assemblies

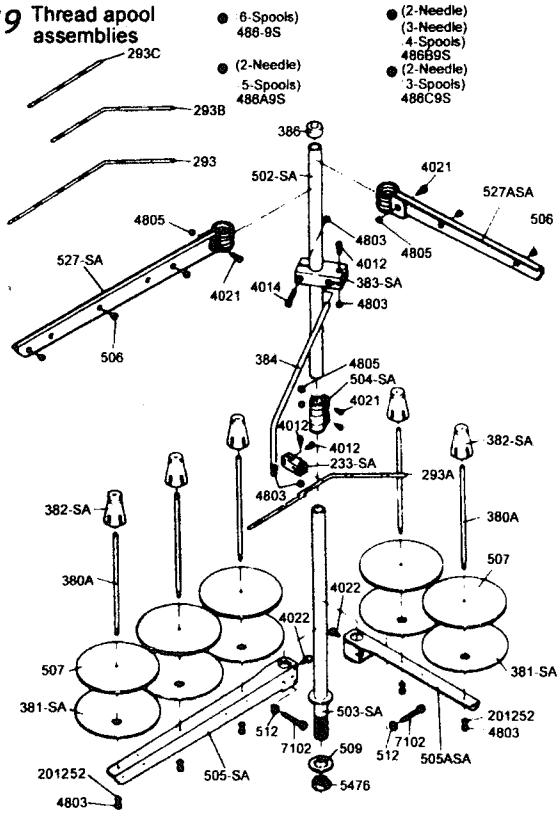

20 Oil plate assemblies

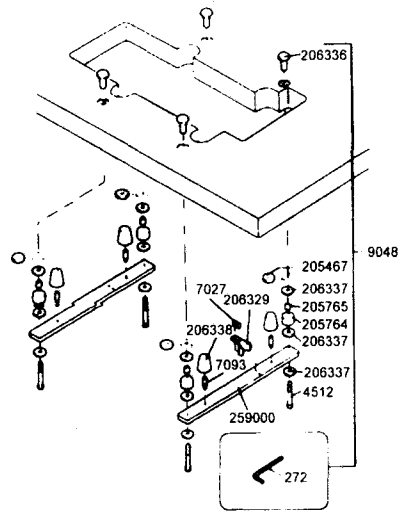

21

● 500-01(Except -01D,01G),03,21  
250030-PD  
250032-PD

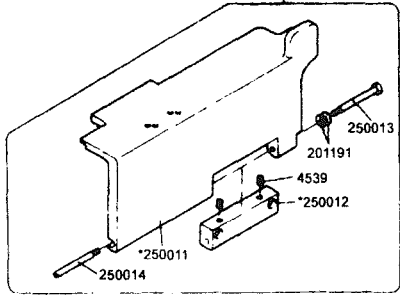

● 500-088,07B,08  
500-01D  
250032BPD

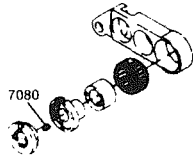
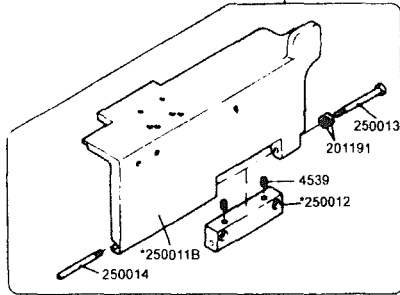

22

● Please confirm the correct part by the gauge parts lists.  
500-01D

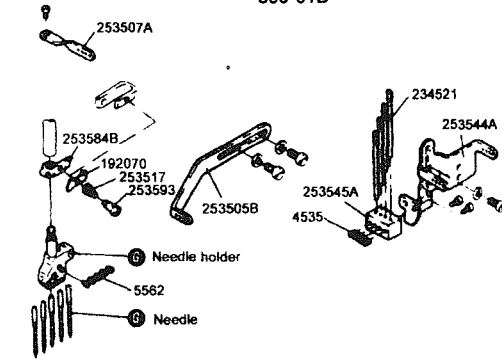

254024-9U

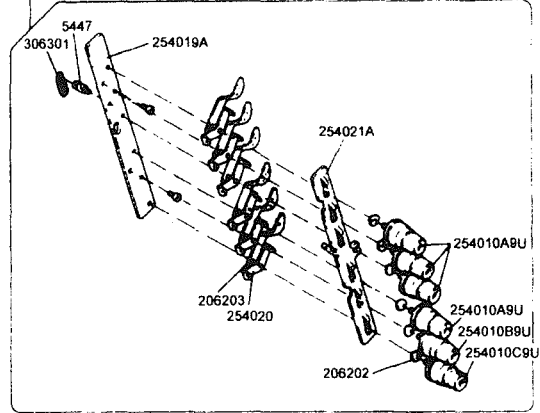

23

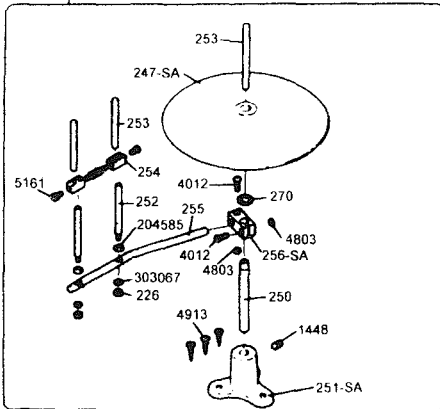
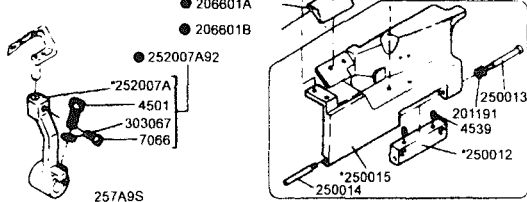
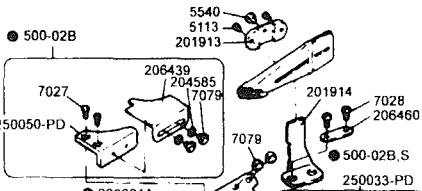

24

500-03

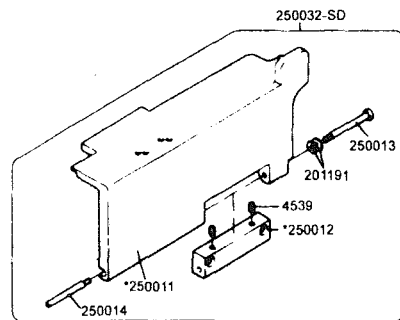

From the library of: Diamond Needle Corp

25 500-05

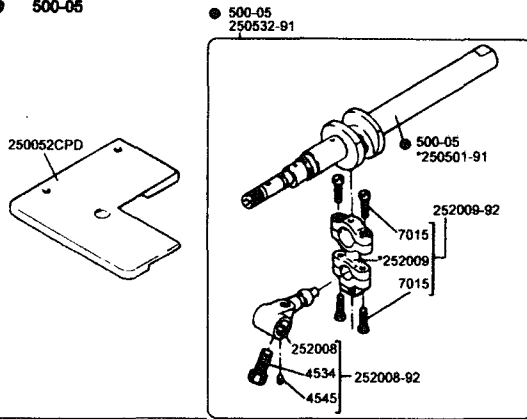

26 Please confirm the correct part the gauge parts lists.

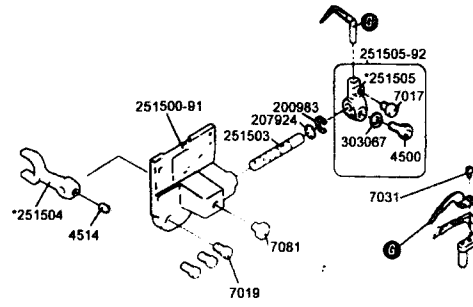

500-05

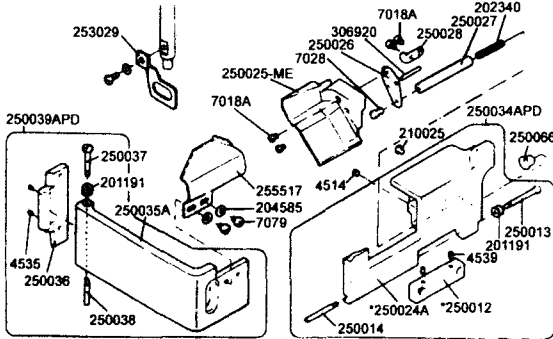

500-05/FT140

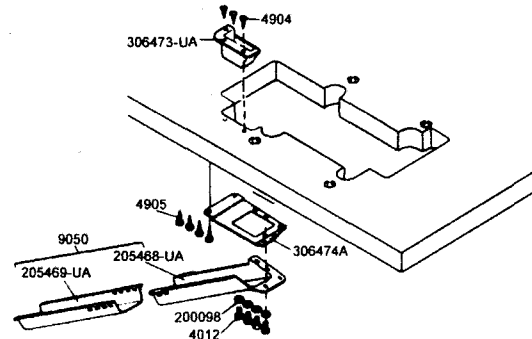

27 500-05/FT140

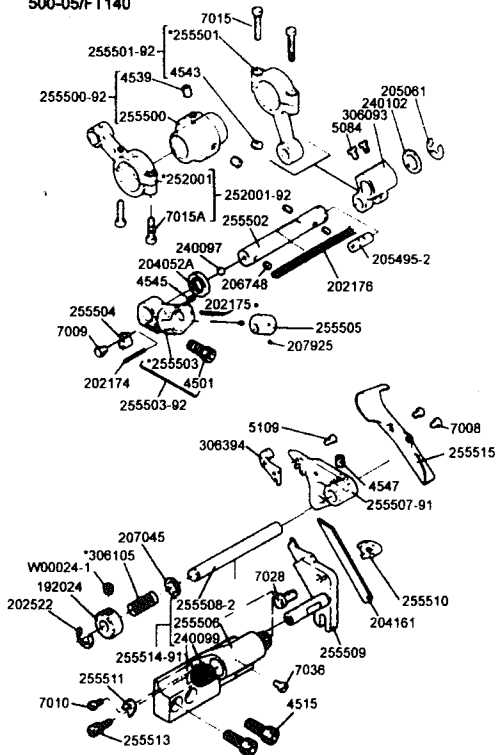

28 500-06,07

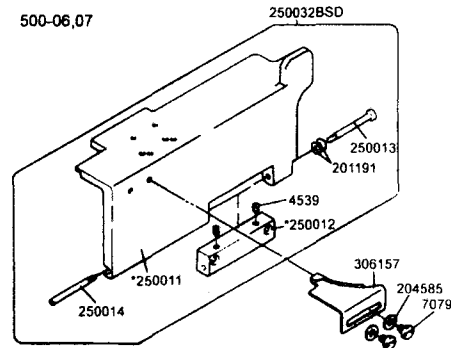

258000-91

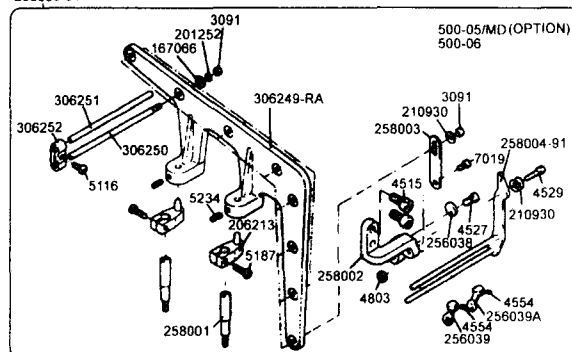

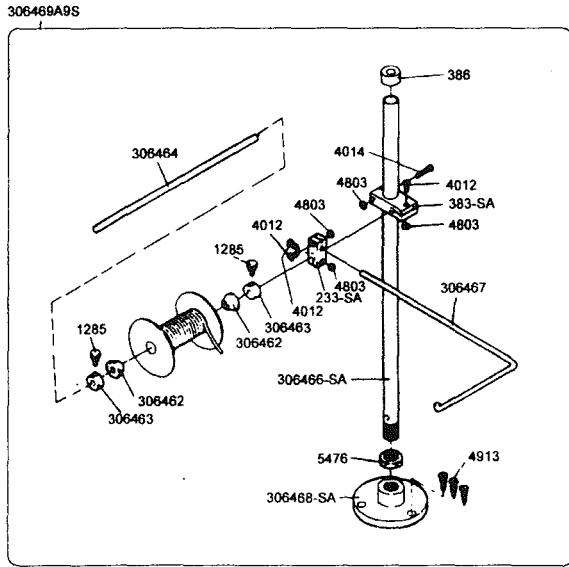

(Put in accessory)

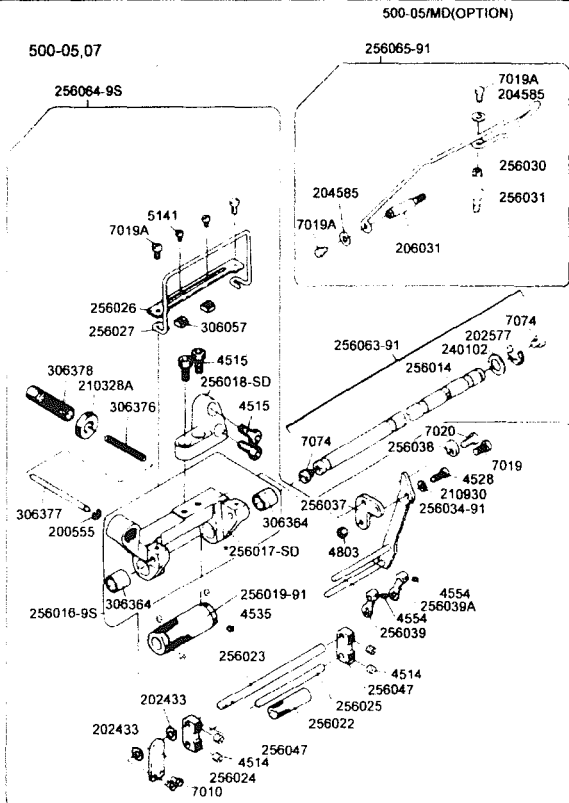
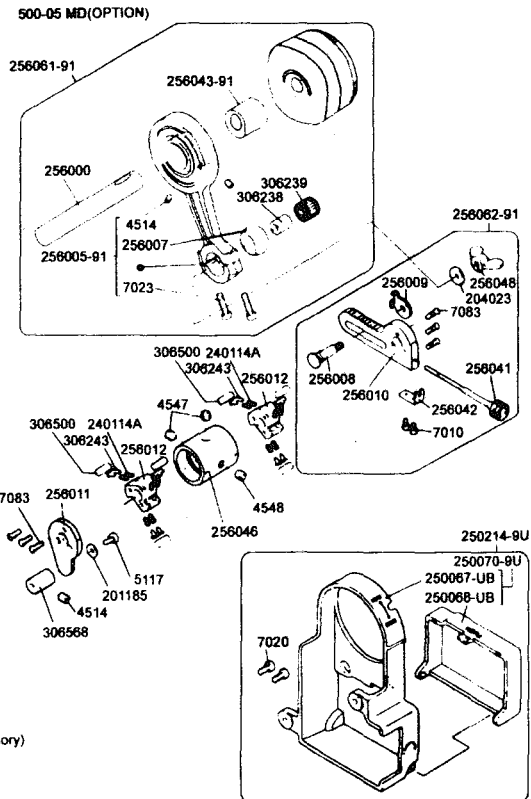

\* = (not for sale)

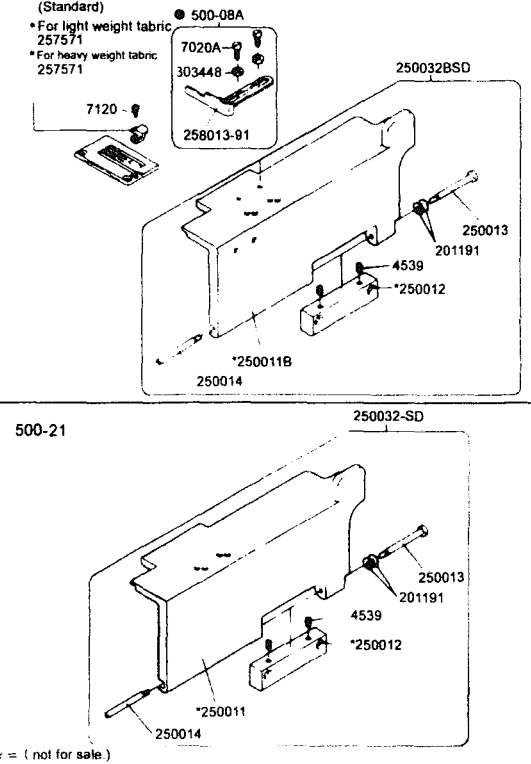

\* = (not for sale)

33 ● Please confirm the correct part by the gauge parts lists. 34

500-21

500-21

GRANKSTAF MECHANISM

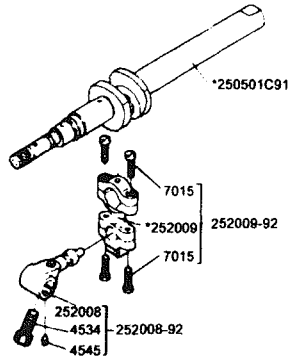

ARM SHAFT MECHANISM

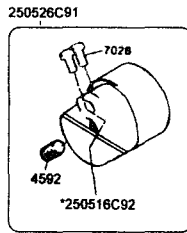

LOOPER MECHANISM

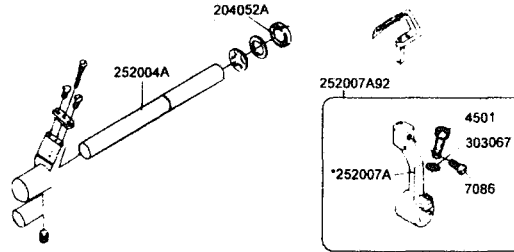

NEEDLE SPREADER  
THREAD HANDLING

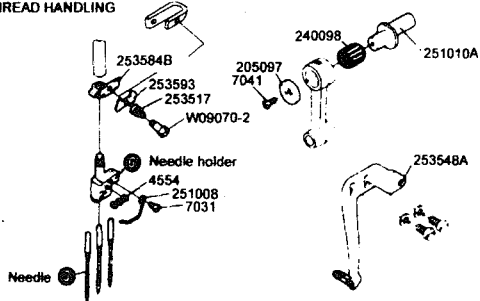

\* = ( not for sale.)

FEED MECHANISM

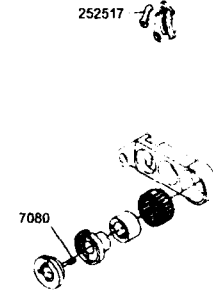

LUBRICATION MECHANISM

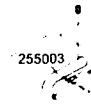

\* = ( not for sale.)

35 ● Please confirm the correct part by the gauge parts lists.

250032-SD

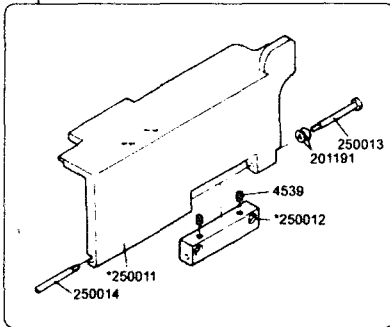

254023H9U

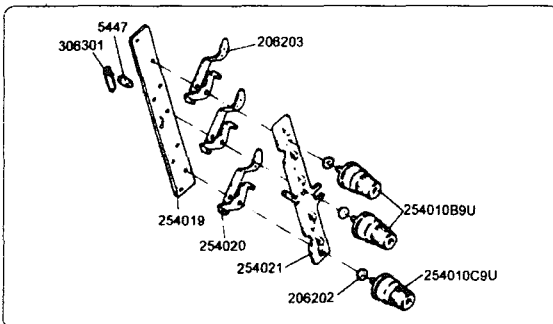

\* = ( not for sale )

500

GAUGE PARTS LIST(1)



MACHINE TYPE /SEC.	GAUGE	NEEDLE HOLDER	NEEDLE PLATE	MAIN FEED DOG	DIFF.FEED DOG	PRESSER FOOT	LOOPER	NEEDLE GUARD FRONT	NEEDLE GUARD REAR	SPREADER	NEEDLE	
500-01CA 500-01CA/M	224	257517-24	257515A24	257206-16F	257258-16F	257460-24	257550E91	257553	257551B	25756S	UY128GAS #9	
	232	" 32	" 32			" 32	257550-91					257550E91
	240	" 40	" 40			" 40						
	248	" 48	" 48			" 48						
	256	" 56	257517A56	" 56								
	264	" 64	" 64	257207-16F	257058-16F	" 64	257550-91					
	348	257518-48	257518A48	257206-16F	257258-16F	257461-48					257550E91	
	356	" 56	257518A56	257207-16F	257259-16F	" 56						
364	" 64	" 64	" 64	" 64								
500-01CB 500-01CB/M	224	257517-24	257515B24	257206-16F	257258-16F	257460-24	257550E91	257553	257551B	25756S	UY128GAS #9	
	232	" 32	" 32			" 32	257550-91					257550E91
	240	" 40	" 40			" 40						
	248	" 48	" 48			" 48						
	256	" 56	257517B56	" 56								
	264	" 64	" 64	257207-16F	257259-16F	" 64	257550-91					
	348	257518-48	257518B48	257206-16F	257258-16F	257461-48					257550E91	
	356	" 56	257518B56	257207-16F	257259-16F	" 56						
364	" 64	" 64	" 64	" 64								
500-01CC 500-01CC/M	224	257517-24	257515C24	257206-16F	257258-16F	257460-24	257550E91	257553	257551B	25756S	UY128GAS #9	
	232	" 32	" 32			" 32	257550-91					257550E91
	240	" 40	" 40			" 40						
	248	" 48	" 48			" 48						
	256	" 56	257517C56	" 56								
	264	" 64	" 64	257207-16F	257259-16F	" 64	257550-91					
	348	257518-48	257516C48	257206-16F	257258-16F	257461-48					257550E91	
	356	" 56	257518C56	257207-16F	257259-16F	" 56						
364	" 64	" 64	" 64	" 64								
500-010DB 500-010DB/M	480	257513-80	257020-80	25723A-16F	257258-16F	257491-80	257550C91	257553	25755A	25756S	SM 1014 #9	
500-01GB 500-01GB/M	356	257518-56	257018B56	257207-16F	257259-16F	257472-56	257550-91	257553	257551B	25756S	UY128GAS #10	
	364	" 64	" 64			" 64						

GAUGE PARTS LIST(2)



MACHINE TYPE /SEC.	GAUGE	NEEDLE HOLDER	NEEDLE PLATE	MAIN FEED DOG	DIFF.FEED DOG	PRESSER FOOT	LOOPER	NEEDLE GUARD FRONT	NEEDLE GUARD REAR	SPREADER	NEEDLE	
500-02BA 500-02BA/M	224	257517-24	257029A24	257214-16F	257280-16F	257317A24	257550E91	257553	257551B	25756S	UY128GAS #9	
	232	" 32	" 32			" 32	257550-91					257550E91
	240	" 40	257030A40			" 40						
	248	" 48	" 48			" 48						
	256	" 56	257032A56	" 56								
	264	" 64	" 64	257216-16F	257282-16F	" 64	257550-91					
	348	257518-48	257031A48	257215-16F	257281-16F	257320A48					257550E91	
	356	" 56	257033A56	257216-16F	257282-16F	257321A56					257550-91	
364	" 64	" 64	" 64	" 64								
500-02BB 500-02BB/M	224	257517-24	257029B24	257214-16F	257280-16F	257317A24	257550E91	257553	257551B	25756S	UY128GAS #9	
	232	" 32	" 32			" 32	257550-91					257550E91
	240	" 40	257030B40			" 40						
	248	" 48	" 48			" 48						
	256	" 56	257032B56	" 56								
	264	" 64	" 64	257216-16F	257282-16F	" 64	257550-91					
	348	257518-48	257031B48	257215-16F	257281-16F	257320A48					257550E91	
	356	" 56	257033B56	257216-16F	257282-16F	257321A56					257550-91	
364	" 64	" 64	" 64	" 64								
500-02BC 500-02BC/M	224	257517-24	257029C24	257214-16F	257280-16F	257317A24	257550E91	257553	257551B	25756S	UY128GAS #9	
	232	" 32	" 32			" 32	257550-91					257550E91
	240	" 40	257030C40			" 40						
	248	" 48	" 48			" 48						
	256	" 56	257032C56	" 56								
	264	" 64	" 64	257216-16F	257282-16F	" 64	257550-91					
	348	257518-48	257031C48	257215-16F	257281-16F	257320A48					257550E91	
	356	" 56	257033C56	257216-16F	257282-16F	257321A56					257550-91	
364	" 64	" 64	" 64	" 64								

GAUGE PARTS LIST(3)



MACHINE TYPE /SECC.	GAUGE	NEEDLE HOLDER	NEEDLE PLATE	MAIN FEED DOG	DIFF.FEED DOG	PRESSER FOOT	LOOPER	NEEDLE GUARD FRONT	NEEDLE GUARD REAR	SPREADER	NEEDLE
500-02SA 500-02SA/M	224	257517-24	257023A24	257208-16F	257261-16F	257350-24	257350E91	257553	257551B	25756S	UY128GAS #3
	232	" 32	" 32			" 32					
	240	" 40	257024A40	257210-16F	257202-16F	257351-40					
	248	" 48	" 48			" 48	257550-91				
	256	" 56	257041A56	257210-16F	257262-16F	257358-56					
	264	" 64	" 64			" 64					
	348	257518-48	257040A48	257209-16F	257261-16F	257359-48	257550E91				
	356	" 56	257025A56	257210-16F	257262-16F	257352-56	257550-91				
364	" 64	" 64			" 64						
500-02SB 500-02SB/M	224	257517-24	257023B24	257208-16F	257260-16F	257350-24	257350E91	257553	257551B	25756S	UY128GAS #9
	232	" 32	" 32			" 32					
	240	" 40	257024B40	257209-16F	257261-16F	257351-40					
	248	" 48	" 48			" 48	257550-91				
	256	" 56	257040B56	257210-16F	257262-16F	257358-56					
	264	" 64	" 64			" 64					
	348	257518-48	257041B48	257209-16F	257261-16F	257359-48	257550E91				
	356	" 56	257025B56	257210-16F	257262-16F	257352-56	257550-91				
364	" 64	" 64			" 64						
500-02SC 500-02SC/M	224	257517-24	257023C24	257208-16F	257260-16F	257350-24	257550E91	257553	257551B	25756S	UY128GAS #9
	232	" 32	" 32			" 32					
	240	" 40	257024C40	257209-16F	257261-16F	257351-40					
	248	" 48	" 48			" 48	257550-91				
	256	" 56	257041C56	257210-16F	257262-16F	257358-56					
	264	" 64	" 64			" 64					
	348	257518-48	257040C48	257209-16F	257261-16F	257359-48	257550E91				
	356	" 56	257025C56	257210-16F	257262-16F	257352-56	257550-91				
364	" 64	" 64			" 64						
500-02CA 500-02CA/M	232	257139A32	257139A32	259123-16F	257260-16F	2572448-32	257550-91	257553	257551B	25756S	UY128GAS #10
240	257140A40	257140A40	259124-16F	257262-16F	257449-40						
500-02CB 500-02CB/M	232	257139B32	257139A32	259123-16F	257260-16F	2572448-32	257550-91	257553	257551B	25756S	UY128GAS #10
240	257140B40	257140A40	259124-16F	257261-16F	257449-40						
500-02CC 500-02CC/M	232	257139C32	257139A32	259123-16F	257260-16F	2572448-32	257550-91	257553	257551B	25756S	UY128GAS #10
240	257140C40	257140A40	259124-16F	257261-16F	257449-40						
500-02DB 500-02DB/M	232	257157B32	257157B32	259128-16F	259234-16F	257449-34	257550-91	257553	257551B	25756S	UY128GAS #10

GAUGE PARTS LIST(4)



MACHINE TYPE /SECC.	GAUGE	NEEDLE HOLDER	NEEDLE PLATE	MAIN FEED DOG	DIFF.FEED DOG	PRESSER FOOT	LOOPER	NEEDLE GUARD FRONT	NEEDLE GUARD REAR	SPREADER	NEEDLE
500-02BA 500-02BA/M	240	257517-40	257087B40	257206-16F	259200-16F	257467-40		257553	257551B	25756S	UY128GAS #9
	248	" 48	" 48			" 48					
	256	" 56	257089B56	257207-16F	259253-16F	" 56	257550-91				
	264	" 64	" 64			" 64					
	348	257518-48	257088B48	257206-16F	259200-16F	257468-48	257550E91				
	356	" 56	257090B56	257207-16F	259253-16F	" 56					
500-02BB 500-02BB/M	240	257517-40	257087B40	257206-16F	259200-16F	257467-40		257553	257551B	25756S	UY128GAS #9
	248	" 48	" 48			" 48	257550-91				
	256	" 56	257089B56	257207-16F	259253-16F	" 56					
	264	" 64	" 64			" 64					
	348	257518-48	257088B48	257206-16F	259200-16F	257468-48	257550E91				
	356	" 56	257090B56	257207-16F	259253-16F	" 56	257550-91				
500-02BC 500-02BC/M	240	257517-40	257091B40	257206-16F	259201-16F	257467-40		257553	257551B	25756S	UY128GAS #9
	248	" 48	" 48			" 48	257550-91				
	256	" 56	257093B56	257207-16F	259254-16F	" 56					
	264	" 64	" 64			" 64					
	348	257518-48	257092B48	257206-16F	259201-16F	257468-48	257750E91				
	356	" 56	257094B56	257207-16F	259254-16F	" 56	257550-91				
500-02BC 500-02BC/M	240	257517-40	257091C40	257206-16F	259201-16F	257467-40		257553	257551B	25756S	UY128GAS #9
	248	" 48	" 48			" 48	257550-91				
	256	" 56	257093C56	257207-16F	259254-16F	" 56					
	264	" 64	" 64			" 64					
	348	257518-48	257092C48	257206-16F	259200-16F	257468-48	257550E91				
	356	" 56	257094C56	257207-16F	259254-16F	" 56	257550-91				
364	" 64	" 64			" 64						



■ 500

GAUGE PARTS LIST(5)



MACHINE TYPE /SECC	GAUGE	NEEDLE HOLDER	NEEDLE PLATE	MAIN FEED DOG	DIFF.FEED DOG	PRESSER FOOT	LOOPER	NEEDLE GUARD FRONT	NEEDLE GUARD REAR	SPREADER	NEEDLE
500-05BA 500-05BA/M	224	257517-24	257049A24	257220-16F	257266-16F	257327A24	257550E91	257553	257551B	25756S	UY128GAS #3
	232	" 32	" 32			" 32					
	240	" 40	257050A40	257221-16F	257267-16F	257328A40					
	248	" 48	" 48			" 48	257550-91				
	256	" 56	257052A56	257222-16F	257268-16F	257329A56					
	264	" 64	" 64			" 64					
	348	257518-48	257051A48	257221-16F	257267-16F	257330A48	257550E91				
	356	" 56	257053A56	257222-16F	257268-16F	257331A56	257550-91				
364	" 64	" 64			" 64						
500-05BB 500-05BB/M	224	257517-24	257049A24	257220-16F	257266-16F	257327A24	257550E91	257553	257551B	25756S	UY128GAS #9
	232	" 32	" 32			" 32					
	240	" 40	257050A40	257221-16F	257267-16F	257328A40	257550-91				
	248	" 48	" 48			" 48					
	256	" 56	257052A56	257222-16F	257268-16F	257329A56					
	264	" 64	" 64			" 64					
	348	257518-48	257051A48	257221-16F	257267-16F	257330A48	257550E91				
	356	" 56	257053A56	257222-16F	257268-16F	257331A56	257550-91				
364	" 64	" 64			" 64						
500-05SA 500-05SA/M	224	257517-24	257049A24	257220-16F	257266-16F	257327A24	257550E91	257553	257551B	25756S	UY128GAS #9
	232	" 32	" 32			" 32					
	240	" 40	257050A40	257221-16F	257267-16F	257328A40	257550-91				
	248	" 48	" 48			" 48					
	256	" 56	257052A56	257222-16F	257268-16F	257329A56					
	264	" 64	" 64			" 64					
	348	257518-48	257051A48	257221-16F	257267-16F	257330A48	257550E91				
	356	" 56	257053A56	257222-16F	257268-16F	257331A56	257550-91				
364	" 64	" 64			" 64						
500-05SB 500-05SB/M	224	257517-24	257049A24	257220-16F	257266-16F	257327A24	257550E91	257553	257551B	25756S	UY128GAS #9
	232	" 32	" 32			" 32					
	240	" 40	257050A40	257221-16F	257267-16F	257328A40	257550-91				
	248	" 48	" 48			" 48					
	256	" 56	257052A56	257222-16F	257268-16F	257329A56					
	264	" 64	" 64			" 64					
	348	257518-48	257051A48	257221-16F	257267-16F	257330A48	257550E91				
	356	" 56	257053A56	257222-16F	257268-16F	257331A56	257550-91				
364	" 64	" 64			" 64						

GAUGE PARTS LIST(6)



MACHINE TYPE /SECC	GAUGE	NEEDLE HOLDER	NEEDLE PLATE	MAIN FEED DOG	DIFF.FEED DOG	PRESSER FOOT	LOOPER	NEEDLE GUARD FRONT	NEEDLE GUARD REAR	SPREADER	NEEDLE
500-05CA 500-05CA/M	224	257517-24	257049A24	257220-16F	257266-16F	257327A24	257550E91	257553	257551B	25756S	UY128GAS #9
	232	" 32	" 32			" 32					
	240	" 40	257050A40	257221-16F	257267-16F	257328A40	257550-91				
	248	" 48	" 48			" 48					
	256	" 56	257052A56	257222-16F	257268-16F	257329A56					
	264	" 64	" 64			" 64					
	348	257518-48	257051A48	257221-16F	257267-16F	257330A48	257550E91				
	356	" 56	257053A56	257222-16F	257268-16F	257331A56	257550-91				
364	" 64	" 64			" 64						
500-05CB 500-05CB/M	224	257517-24	257049A24	257220-16F	257266-16F	257327A24	257550E91	257553	257551B	25756S	UY128GAS #9
	232	" 32	" 32			" 32					
	240	" 40	257050A40	257221-16F	257267-16F	257328A40	257550-91				
	248	" 48	" 48			" 48					
	256	" 56	257052A56	257222-16F	257268-16F	257329A56					
	264	" 64	" 64			" 64					
	348	257518-48	257051A48	257221-16F	257267-16F	257330A48	257550E91				
	356	" 56	257053A56	257222-16F	257268-16F	257331A56	257550-91				
364	" 64	" 64			" 64						

■ 500

GAUGE PARTS LIST(7)



MACHINE TYPE /SECC.	GAUGE	NEEDLE HOLDER	NEEDLE PLATE	MAIN FEED DOG	DIFF.FEED DOG	PRESSER FOOT	LOOPER	NEEDLE GUARD FRONT	NEEDLE GUARD REAR	SPREADER	NEEDLE
500-06BA 500-06BA/M 500-07BA 500-07BA/M	232	257517-32	257044A32	257214-16F	257260-16F	257337A32	257550-91	257553	257551B	25756S	UY128GAS #9
	240	" 40	257045A40	257215-16F	257261-16F	257338A40					
	248	" 48	" 48			" 48					
	256	" 56	257047A56	257216-16F	257262-16F	257339A56					
	264	" 64	" 64			" 64					
	348	257518-48	257046A48	257215-16F	257261-16F	257339A48	257550E91				
	356	" 56	257048A56	257216-16F	257262-16F	257341A56	257550-91				
364	" 64	" 64	" 64								
500-06BB 500-06BB/M 500-07BB 500-07BB/M	232	257517-32	257044B32	257214-16F	257260-16F	257337A32	257550-91	257553	257551B	25756S	UY128GAS #9
	240	" 40	257045B40	257215-16F	257261-16F	257338A40					
	248	" 48	" 48			" 48					
	256	" 56	257047B56	257216-16F	257262-16F	257339A56					
	264	" 64	" 64			" 64					
	348	257518-48	257046B48	257215-16F	257261-16F	257339A48	257550E91				
	356	" 56	257048B56	257216-16F	257262-16F	257341A56	257550-91				
364	" 64	" 64	" 64								
500-08AB 500-08AB/M	240	257517-40	257084B40	257206-16F	259209-16F	257480-40	257550-91	257553	257551B	25756S	UY128GAS #9
	248	" 48	" 48	257207-16F	259210-16F	" 48					UY128GAS #10
	356	257518-56	257095B56			257461-56					" 64
500-08AC 500-08AC/M	240	257517-40	257084C40	257206-16F	259209-16F	257160-48	257550-91	257553	257551B	25756S	UY128GAS #9
	248	" 48	" 48	257207-16F	259210-16F	" 48					UY128GAS #10
	256	257518-56	257095C56			257461-56					" 64
	364	" 64	" 64	" 64	" 64						

GAUGE PARTS LIST(8)



MACHINE TYPE /SECC.	GAUGE	NEEDLE HOLDER	NEEDLE PLATE	MAIN FEED DOG	DIFF.FEED DOG	PRESSER FOOT	LOOPER	NEEDLE GUARD FRONT	NEEDLE GUARD REAR	SPREADER	NEEDLE
500-21BA 500-21BA/M	356	257501C56	257022A56	257207-16F	257259-16F	257466-56	257550A91	257553	257551B	25756S	UY128GAS #10
	364	" 64	" 64			" 64					
500-21BB 500-21BB/M	356	257501C56	257022B56	257207-16F	257259-16F	257466-56	257550A-91	257553	257551B	25756S	UY128GAS #10
	364	" 64	" 64			" 64					
50082AB/M	224	257517-24	257119-24	257206-16F	257223-16F	257460-24	257550E91	257553	257551B	25756S	UY128GAS #10
	240	" 40	" 40			" 40					
	248	" 48	" 48	" 48							
	356	257518-56	257120-56	257207-16F	257224-16F	257461-56	257550-91				UY128GAS #10
364	" 64	" 64	" 64								



**SHANGHAI HUIGONG NO.3 SEWING MACHINE FACTORY**

**ADD: 1418, Yishan Road, Shanghai, China**

**Zip Code: 201103**

**Overseas Business: TEL: 86-21-64853303 FAX: 86-21-64854304**

**E-mail: [highlead@online.sh.cn](mailto:highlead@online.sh.cn) <http://www.highlead.com.cn>**

The description covered in this manual is subject to change for improvement of the commodity without notice

2006.9. Printed