



HIGHLEAD

GK0088

2-Needle-Pin-Point Chainstitch Sewing Machine

**Instruction Manual
Parts Catalog**

SHANGHAI HUIGONG NO.3 SEWING MACHINE FACTORY

---- CONTENTS ----

1. Precautions before starting operation.....	1
1) Safety precautions.....	1
2) Precaution before Starting Operation.....	1
3) Precaution for Operating Conditions.....	1
2. How to use the sewing machine.....	1
1) How to set the needle.....	1
2) How to threading.....	1
3) Adjustment of stitch length.....	2
4) Pressing for sewn goods.....	2
5) Sewing condition.....	2
6) Upper thread tension.....	2
3. Caution for use to use the sewing machine.....	3
1) Oiling.....	3
2) Clean periodically in accordance with using frequency.....	4
4. Outline of machine adjustment.....	4
1) Timing of needle and feed dog.....	4
2) Height of needle bar.....	4
3) How to fit needle and looper.....	5
4) Adjustment of needle guide.....	6
5) Adjustment of thread tension spring.....	6
6) Adjustment of thread tightening.....	7
5. Parts catalog.....	8
A) Arm bed & Its accessories.....	8
B) Sewing mechanism.....	10
C) Feeding and feed lifting & Lower shaft mechanism.....	13
D) Stitch regulator mechanism.....	16
E) Presser foot mechanism.....	18
F) Oil lubrication mechanism.....	20
G) Accessories.....	22

1. Precautions before starting operation

1) Safety precautions:

(1) When turning the power on, keep your hands and fingers away from the area around/under the needle and the area around the pulley.

(2) Power must be turned off when the machine is not in use, or when the operator leaves the seat.

(3) Power must be turned off when tilting the machine head, installing or removing the "V" belt, adjusting the machine, or when replacing.

(4) Avoid placing fingers, hairs, bars etc., near the pulley, "V" belt, bobbin winder pulley, or motor when the machine is in operation.

(5) Do not insert fingers into the thread take-up cover, under/around the needle, or pulley when the machine is in operation.

(6) If a belt cover, finger guard, eye guard are installed, do not operate the machine without these safety devices.

2) Precautions before starting operation:

(1) If the machine's oil pan has an oil sump, never operate the machine before filling it.

(2) If the machine is lubricated by a drop oiler, never operate the machine before lubricating.

(3) When a new sewing machine is first turned on, verify the rotational direction of the pulley with the power on. (The pulley should rotate counterclockwise when viewed from the pulley)

(4) Verify the voltage and (single or three) phase with those given on the machine nameplate.

3) Precautions for operating conditions:

1) Avoid using the machine at abnormally high temperatures (35°C or higher) or low temperatures (5°C or lower)

2) Avoid using the machine in dusty conditions.

2. How to use the sewing machine

1) How to set the needle

Put in the needle as far as it comes to the end, keep the groove on the left side and tighten the screw.

Note: When fitting the needle, tighten the right side screw softly and tighten the of this side.

2) How to threading

Keep the thread take-up lever at its highest position thread in numerical order.



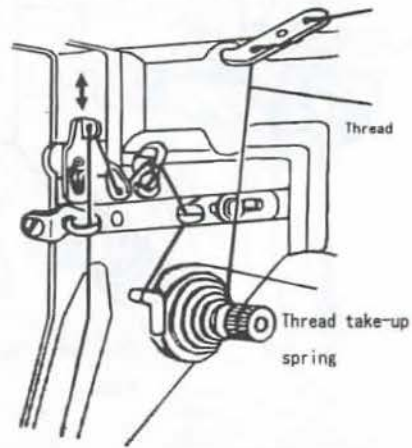
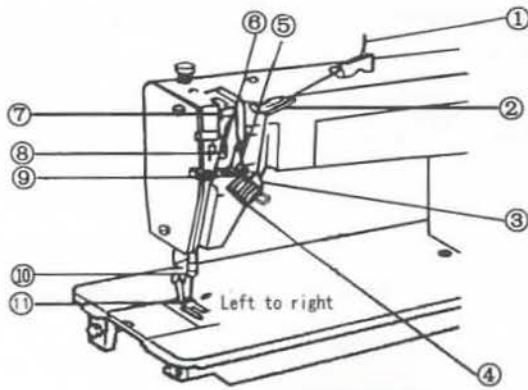

3) Adjustment of stitch length

Note: When you make the stitch length small, turn the stitch length dial.

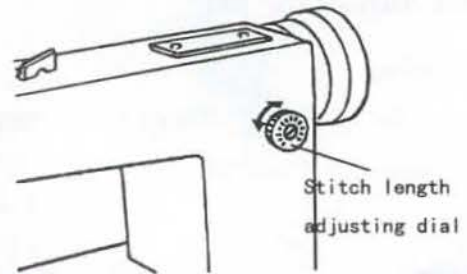

4) Pressing for sewn goods

Standard pressure of the feed dog is obtained when the upper surface of the presser regulating thumb screw is in the position approximately 20mm above the arm surface. Increase the pressure by turning the pressure regulating thumb screw, if the sewing cloth is skipped stitch due to the hook needle catching a fiber of the cloth, or other reasons depending on the state of the sewing cloth.

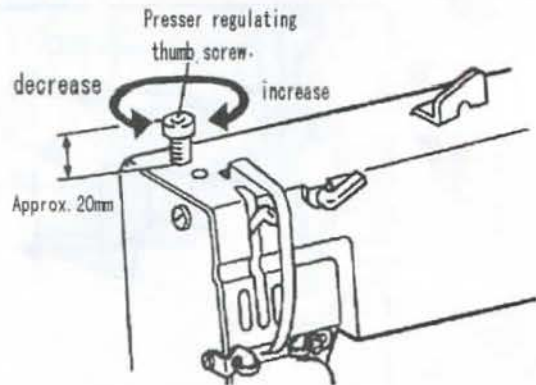

5) Sewing condition

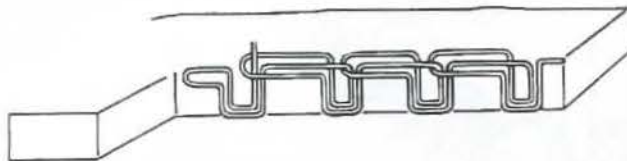

Well-balanced good stitch.

6) Upper thread tension

Adjust by turning the tension regulating thumb nut. In the case of garment sewing with special thread and cloth, the upper thread tension is adjusted with the check spring tension and the working volume of the thread take-up spring too.

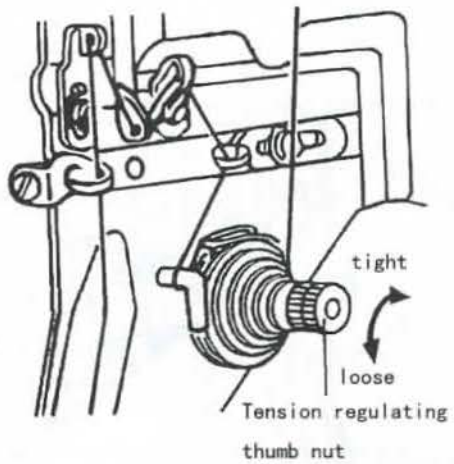

3. Caution for use

1) Oiling

Before running, oil a proper quantity necessary at places marked arrow.

- ←—⊙ Plenty of drops, 5cc
- ←—○ 5-6 drops
- ←— 1-2 drops

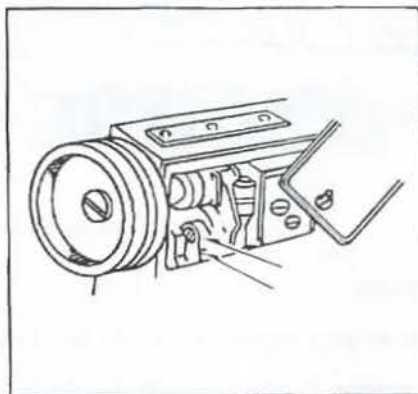
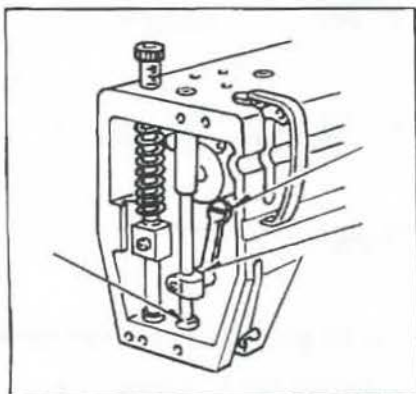
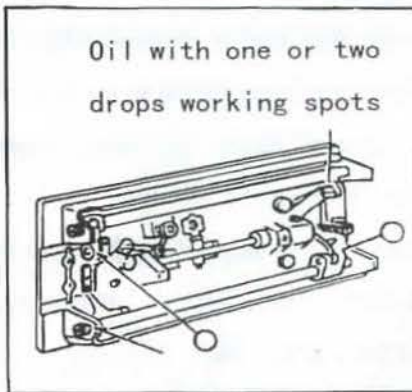
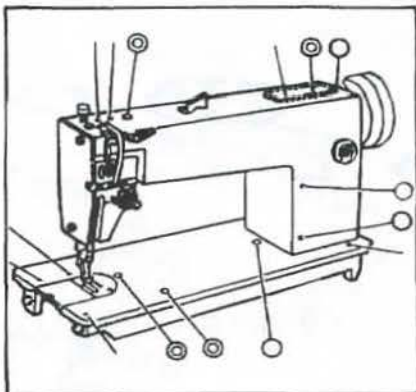

2) Clean periodically in accordance with using frequency

Remove the needle plate. Take off dust in the grooves of the feeder. As for assembling of the needle plate, turn the screw 2 or 3 times with your hand and tighten it evenly with a long screwdriver.

Note: When fitting the needle plate, fit so that the needle might come to the center of the hole of the needle plate.

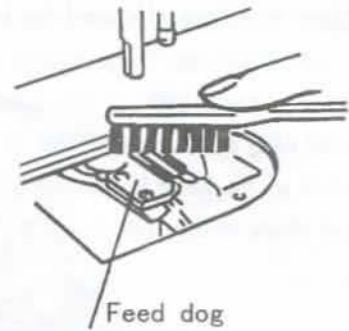

4. Outline of machine adjustment

1) Timing of needle and feed dog

The height of feed dog from the needle plate to the top of feeder teeth shall be approximately 1mm. To adjust height of the feed dog, move the feed up or down by loosening the screw (Fig.1). To adjust the trimming of the needle and feed dog properly, set the feed dial to "8" and make sure that the top of the parent needle enters approximately 0 to 1mm from the needle plate as illustrated in Fig.2, when the needle top is flush with the needle plate after feeding has been completed. If the timing of the feed dog is earlier, proper thread tension cannot be obtained and the sewing cloth will get caught by the needle easily. To adjust the timing of the feed dog, use the feed cam. To advance the timing, move the feed cam to the near side by loosening the two feed cam set-screws "A" as illustrated in Fig.3. To retard the timing, move the feed cam to the far side.

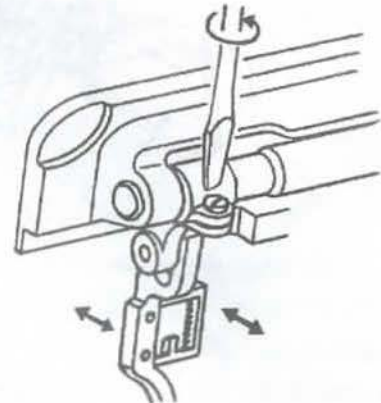

Fig. 1

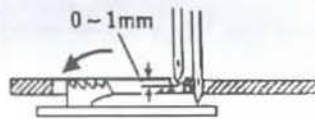

Fig. 2

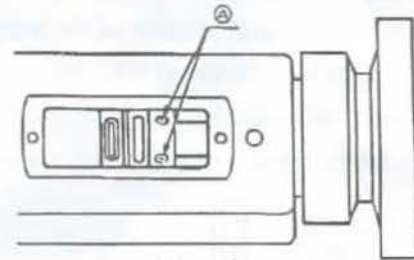

Fig. 3

2) Height of needle bar

When the needle bar is at the top dead point, a standard distance (Fig.4, "B") between the needle plate is as given in the Table 1. Check the proper distance, since the thread loop of the parent needle is changed depending on the type of the thread to be used. To adjust the height of the needle bar, loosen the needle bar holder set screw as illustrated in Fig.5.

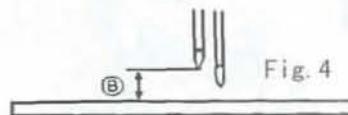

Fig. 4

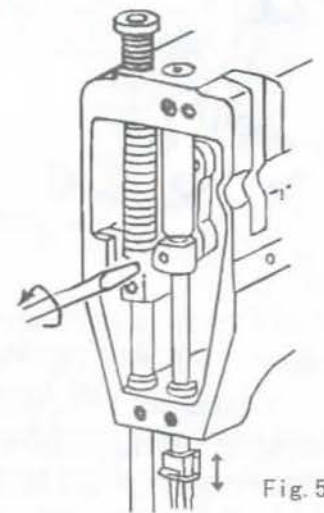

Fig. 5

Needle gauge (mm)	Size B (mm)	
	Tetoron thread	Cotton thread
2	8~8.5	7.5~8

Table 1

3) How to fit needle and looper

(1) When the large looper is in its advance end position, the size between the side of the hook needle and the large looper slot bottom (Fig.6, "C") shall be as given in Table 2. To adjust the position of the large looper, loosen the tightening screw in the large looper block as illustrated in Fig.7.

	Size C (mm)
Tetoron thread	0~1
Cotton thread	1~2

Table 2

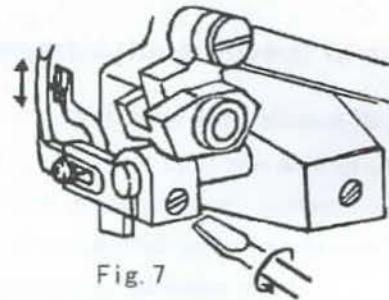
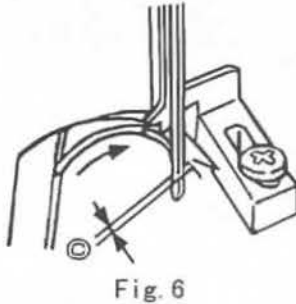

(2) When the needle bar is at the lowest dead point, the distance between the large looper top and the side of the parent needle (Fig.8, "D") shall be as given in Table 3. To adjust this distance, adjust the travel amount (angle of the oscillating block) by changing the position of the tightening screw in the large looper adjusting arm as illustrated in Fig.9. Decrease the travel amount, if the size "D" is excessive, or increase the travel amount if the size "D" is insufficient. To decrease the travel amount, loosen the tightening screw with a spanner and move the large looper adjusting arm so that it clears the large looper shaft. To increase the travel amount, move the large looper adjusting arm so that it comes closer to the large looper shaft. Since the travel position of the large looper (Fig.6, "C") and the timing of the large looper to the needle will be changed by this adjustment, align the needle with the looper while confirming the proper timing.

	Size D (mm)
Tetoron thread	1~2
Cotton thread	3~5

Table 3

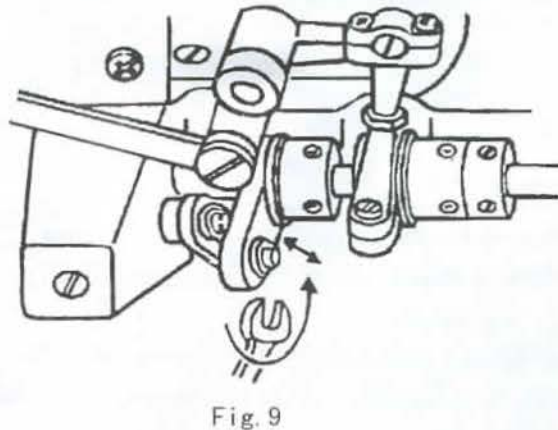

(3) When the top of the large looper is aligned with the center of the parent needle after the large looper has been advanced from its back end position, the top of the large looper shall be 2 to 3mm above the upper end of the needle hole in the parent needle as illustrated in Fig.10. To adjust this position, loosen the setscrew of the large looper.

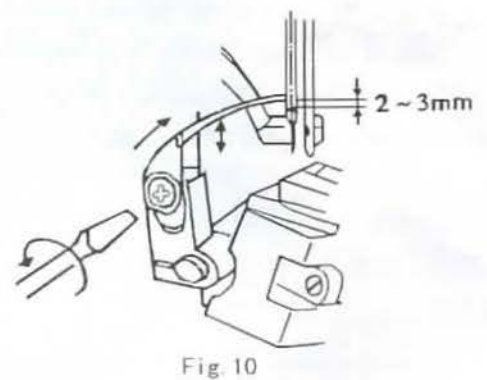

(4) When the small looper is in its left most position, the position of the slot bottom in the small looper must come out 1 to 2mm from the side face of the hook needle as illustrated in *Fig.11*. If this projection is excessive, the chain-off thread will be difficult to come out. To adjust the position of the small looper, loosen the setscrew in the small looper block as illustrated in *Fig.12*.

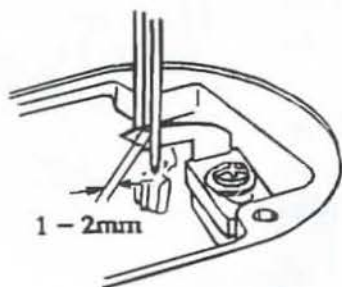

Fig. 11



Fig. 12

(5) The trimming of the small looper is almost same as the timing of the large looper. Adjust the timing while confirming the state that the threads is properly threaded through the hook needle. To adjust the timing of the small looper, use the right large rod. To advance the timing, loosen the two setscrews in the right large rod with a hexagon wrench (2.5mm) as illustrated in *Fig.13*, and move the hexagon wrench up. To retard the timing move the hexagon wrench down. Tighten up the set-screws making sure that the setscrews are closely fit to the collar on the right-hand side.

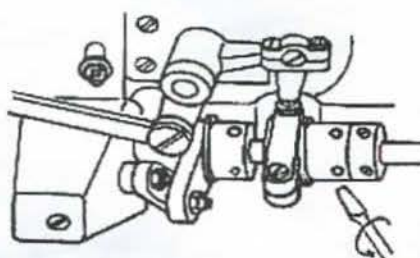

Fig. 13

4) Adjustment of needle guide

Install the needle guide to the upper and lower side, making sure that the needle guide will not come into contact with the lower surface of the large looper (*Fig.14*, "E"). To adjust this position, position the needle guide by loosening the setscrew in the needle guide as illustrated in *Fig.14*.

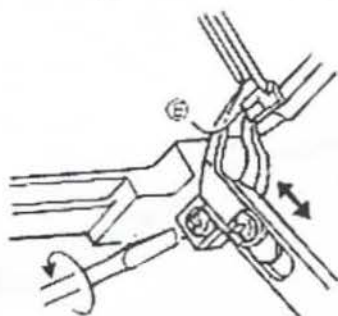

Fig. 14

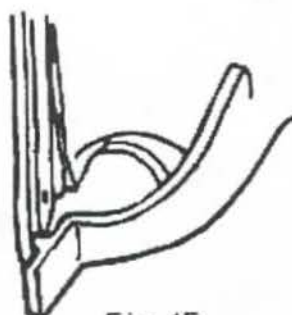

Fig. 15

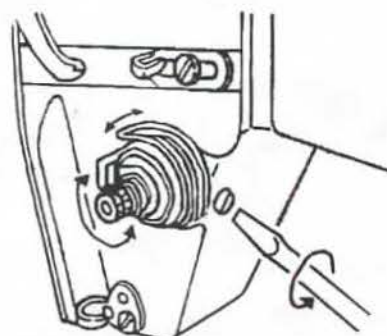

Fig. 16

5) Adjustment of thread tension spring

when threading the large looper (*Fig.15*), reduce the working volume of the thread tension spring, if the loop of the parent needle thread is insufficient. Or increase the working volume, if the loop is excessive. Excessive or insufficient loop size may cause jumping of stitches. To adjust the working volume of the thread tension spring (*fig.16*), loosen the small screw in the upper thread adjuster and turn the upper thread adjuster (upper thread adjusting shaft) all the way so as to adjust the distance between the thread adjuster, confirm the close fit of the tensioner shoe by moving the presser foot down. If this tensioner shoe is raised, the thread may not be tightened

properly.

6) Adjustment of thread tightening

Basic state of the thread tension is that the thread is not tightened or loosened when the take-up lever is in its bottom position while the sewing (*Fig.17*). At this time, if tension is applied to the thread, tighter thread tension will be obtained. But the looper makes a thread coming out sound and the thread is lifted on the lower side. On the contrary, if there is any slack in the thread, the thread will fail to be lightened properly. To adjust the thread tension, move the upper thread adjusting guard located on the left-hand side up or down. When this guard is moved up, the thread will be tightened and the thread will be loosened when this guard is moved down.

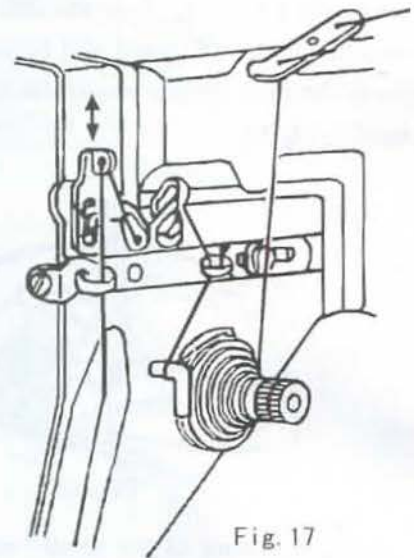
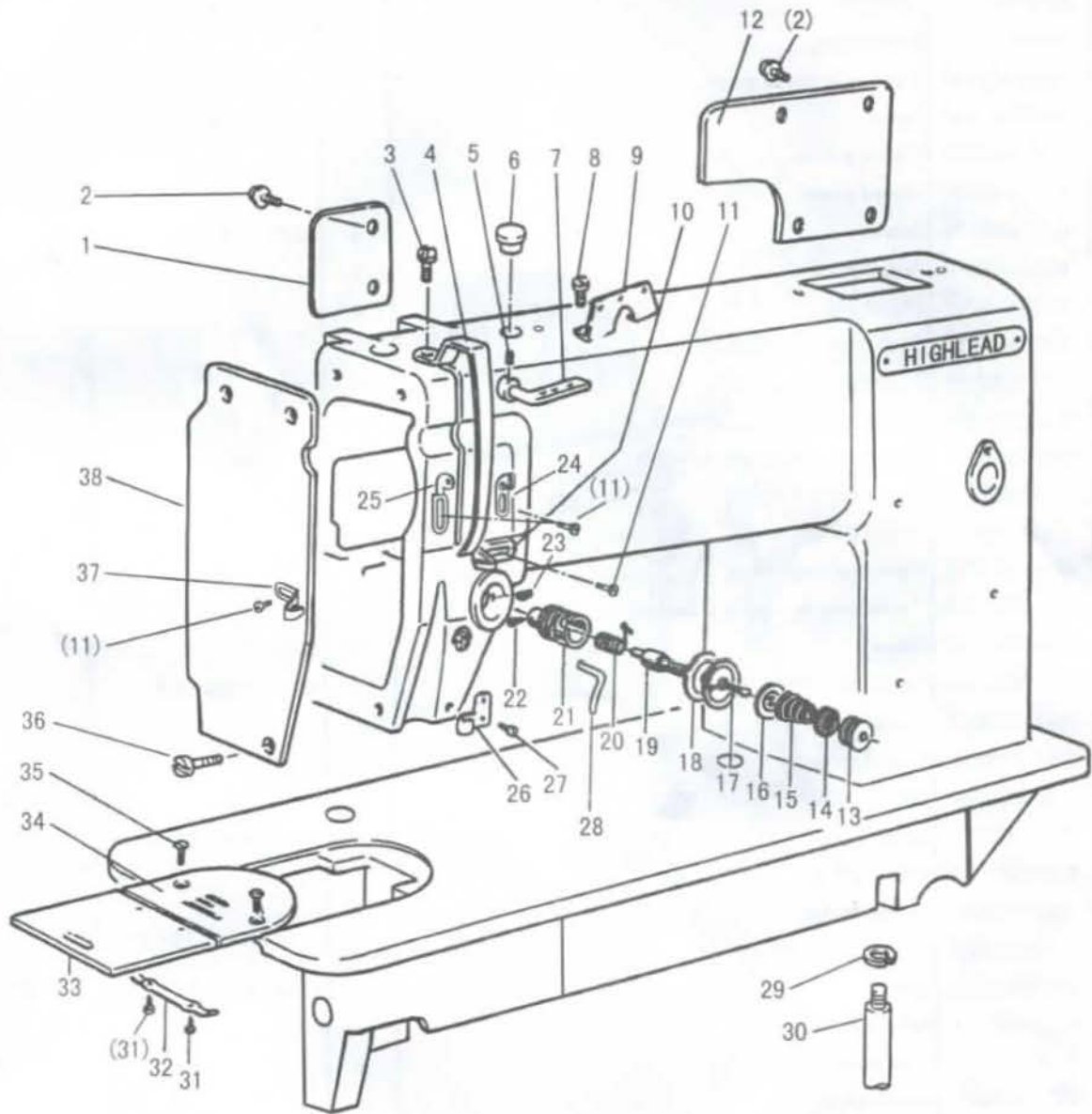

Fig. 17

A.ARM BED AND ITS ACCESSORIES



From the library of: Diamond Needle Corp

A.ARM BED AND ITS ACCESSORIES

Fig. No.	Part No.	Description	Pcs.	Remarks
A01	H8415B8001	Oil shield plate	1	
A02	HA300B2170	Screw	6	SM11/64(40)×9
A03	HA300C2030	Screw	1	SM11/64(40)×8
A04	HA300C2020	Thread take-up cover	1	
A05	HA100B2110	Set screw	1	SM11/64(40)×5.5
A06	H2000B2010	Rubber plug	1	
A07	HA100B2100	Three hole thread guide	1	
A08	HA700B2060	Screw	1	SM11/64(40)×8
A09	HA700B2050	Thread guide	1	
A10	HA100B2140	Thread guide	1	
A11	HA106B0676	Screw	4	SM9/64(40)×6
A12	H8414B8001	Arm side cover	1	
A13	HA310B0701	Thumb nut	1	
A14	HA115B7010	Thumb nut revolution stopper	1	
A15	HA115B0703	Thread tension spring	1	
A16	HA310B0702	Thread tension releasing discs	1	
A17	HA115B0709	Thread tension releasing pin	1	
A18	HA310B0705	Thread tension discs	2	
A19	HA115B0701	Thread tension stud	1	
A20	HA115B0706	Thread take-up spring	1	
A21	HA310B0703	Thread tension regulator bushing	1	
A22	HA115B0708	Screw	1	SM9/64(40)×4
A23	HA300B2080	Set screw	1	SM15/64(28)×6.8
A24	HA106B0675	Thread guide	1	
A25	H8418B8001	Thread guide	1	
A26	HA500C2060	Thread guide	1	
A27	HA500C2070	Screw	1	SM9/64(40)×5
A28	H3000B2130	Thread guide	1	
A29	H005008060	Spring washer	1	
A30	H2009B0653	Leg	1	
A31	HA124B0713	Screw	2	SM3/32(56)×2.2
A32	HA324B0711	Spring for slide plate	1	
A33	HA124B0711	Slide plate	1	
A34	H8416B8001	Needle plate	1	
A35	H2000B2050	Screw	2	SM11/64(40)×8.5
A36	HA300B2170	Screw	3	SM11/64(40)×9
A37	HA607B0671	Thread guide	1	
A38	H8413B8001	Face plate	1	

B.SEWING MECHANISM

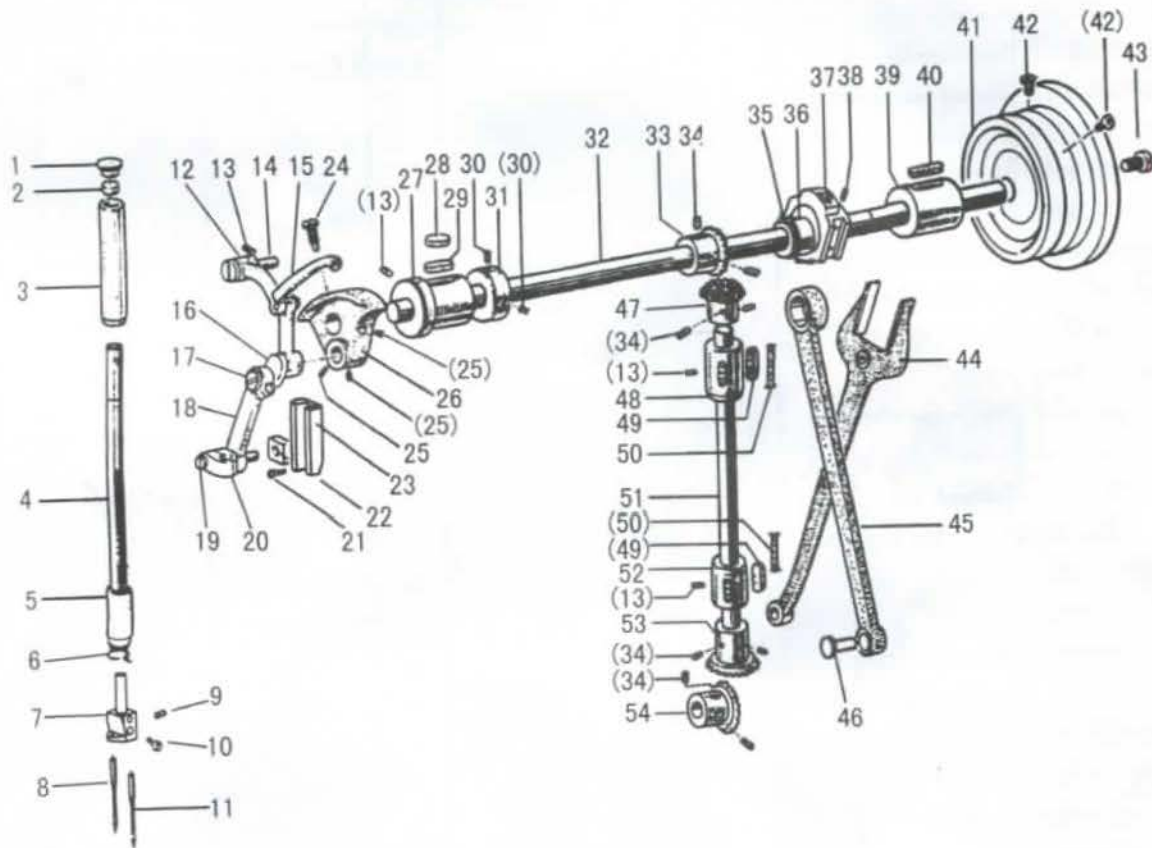

From the library of: Diamond Needle Corp

B.SEWING MECHANISM

Fig. No.	Part No.	Description	Pcs.	Remarks
B01	HA300B2090	Rubber plug	1	
B02	HA100C2100	Felt	1	
B03	H2009B0067	Needle bar bushing (upper)	1	
B04	H8404G8001	Needle bar	1	
B05	HA300C2060	Needle bar bushing (under)	1	
B06	HA300C2070	Thread guide	1	
B07	H8405G8001	Needle clamp	1	
B08	H2404D0653	Needle	1	DP×5 #16
B09	HA100B2110	Screw	1	SM11/64(40)×5.5
B10	HA100C2170	Screw	1	SM1/8(44)×4.5
B11	H8406G8001	Hook needle	1	CP×170 #16
B12	HA304C0012	Thread take-up lever link	1	
B13	HA100C2020	Set screw	4	SM15/64(28)×10
B14	HA104C0653	Hinge pin	1	
B15	HA304C0011	Thread take-up lever assy.	1	
B16	H8404H8001	Thread take-up crank	1	
B17	HA104C0656	Screw(left-handed)	1	
B18	HA304C0653	Needle bar link	1	
B19	HA104C0659	Screw	1	SM9/64(40)×6
B20	HA104C0658	Needle bar adaptor	1	
B21	HA300C2030	Screw	2	SM11/64(40)×8
B22	HA100C2200	Square block	1	
B23	HA100C2180	Needle bar connecting link guide	1	
B24	HA100C2070	Screw	1	SM9/32(28)×14
B25	HA307C0662	Screw	3	SM1/4(40)×6
B26	H2005C0065	Needle bar crank	1	
B27	H2009B0741	Bushing for arm shaft (left)	1	
B28	H2009B0743	Felt	1	
B29	H2009B0742	Felt	1	
B30	HA105D0662	Screw	2	SM1/4(40)×4
B31	HA108G0661	Collar	1	
B32	H2000C2010	Arm shaft	1	
B33	HA113D2112	Bevel gear for arm shaft	1	
B34	HA108C0663	Screw	8	SM1/4(40)×7
B35	HA112D3012	Stop ring	1	
B36	HA3411D108	Feed and feed lifting eccentric	1	
B37	HA3411D208	Eccentric sleeve	1	
B38	HA3411D308	Screw	2	SM15/64(28)×7
B39	H2009B0732	Bushing for arm shaft (right)	1	
B40	H2009B0731	Felt	1	
B41	H2404E0061	Pully	1	
B42	HA110D0672	Screw	2	SM15/64(28)×12
B43	HA100D2080	Screw	1	SM11/32(28)×10

B.SEWING MECHANISM

Fig. No.	Part No.	Description	Pcs.	Remarks
B44	H2006C0021	Feed forked connecting rod	1	
B45	H2006C0012	Crank rod	1	
B46	HA100G2070	Pin	1	
B47	HA113D2122	Bevel gear for vertical shaft(upper)	1	
B48	H2009B0713	Vertical shaft bushing(upper)	1	
B49	H2009B0711	Felt	1	
B50	H2009B0712	Oil wick	1	
B51	H2004D0065	Vertical shaft	1	
B52	H2009B0721	Vertical shaft bushing(lower)	1	
B53	HA113D2222	Bevel gear for vertical shaft(lower)	1	
B54	HA113D2212	Bevel gear for hook shaft	1	

C.FEEDING AND FEED LIFTING & LOWER SHAFT MECHANISM

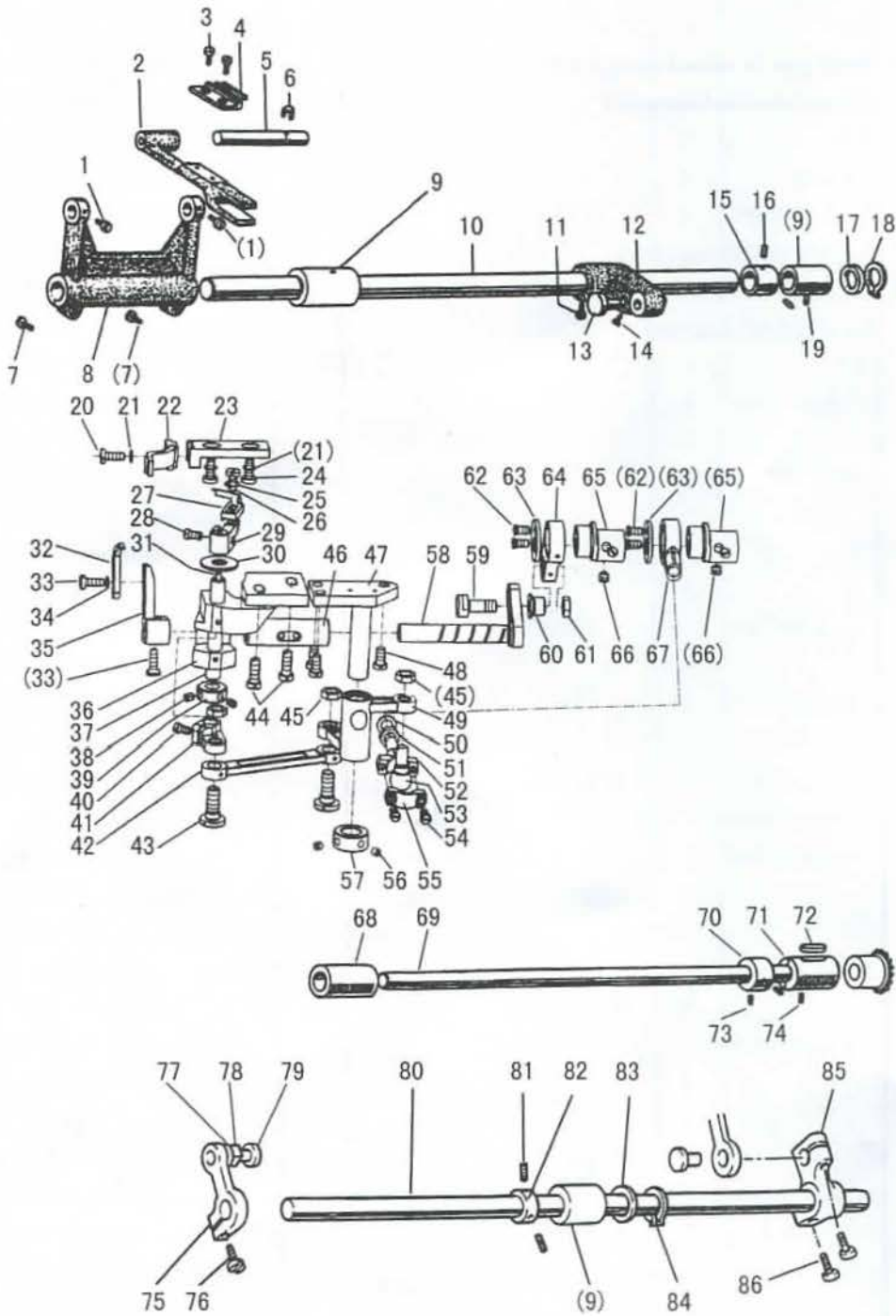

C.FEEDING AND FEED LIFTING & LOWER SHAFT MECHANISM

Fig. No.	Part No.	Description	Pcs.	Remarks
C01	HA300C2030	Screw	2	SM11/64(40)×8
C02	H2004L0661	Feed bar	1	
C03	HA104G0654	Screw	2	SM1/8(44)×6
C04	H8404K8001	Feed dog	1	
C05	H2004L0067	Feed bar holder stud	1	
C06	H007013050	E-type stop ring 5	1	
C07	HA304G0656	Screw	2	SM3/16(28)×15
C08	H2004L0653	Feed rock shaft crank (left)	1	
C09	H2009B0069	Feed rock shaft bushing	3	
C10	H2005L0065	Feed rock shaft	1	
C11	H2012N0652	Screw	1	SM1/4(24)×16
C12	H2012N0681	Feed rock shaft crank (right)	1	
C13	HA100G2070	Pin	1	
C14	HA113F0684	Screw	1	SM15/64(28)×8.5
C15	HA108G0661	Collar	1	
C16	HA105D0662	Screw	2	SM1/4(40)×4
C17	HA100G2130	Washer	1	
C18	H007009150	C-type stop ring 15	1	
C19	HA100C2020	Screw	1	SM15/64(28)×10
C20	HE017B8001	Screw	1	SM9/64(40)×10
C21	H005004040	Washer	3	
C22	H8427E8001	Needle guard	1	
C23	H8426E8001	Needle holder	1	
C24	HA100H2150	Screw	2	SM9/64(40)×11
C25	H005001040	Washer	1	
C26	HA7311CH06	Screw	1	SM9/64(40)×8
C27	H8436E7101	Small looper assy.	1	
C28	HA7311CC06	Screw	1	SM9/64(40)×6.5
C29	H8434E8001	Small looper holder	1	
C30	H8435E8001	Washer	1	
C31	H8431E8001	Oil wick	1	
C32	H8424E8001	Large looper	1	
C33	HA7311CH06	Screw	2	SM9/64(40)×8
C34	H005001040	Washer	1	
C35	H8423E8001	Large looper block	1	
C36	H8429E8001	Block	1	
C37	H8430E8001	Shaft	1	
C38	HA711B0681	Screw	2	SM9/64(40)×4.5
C39	H8432E8001	Collar	1	
C40	HA7311CD06	Screw	1	SM9/64(40)×8.5
C41	H8433E8001	Small looper block	1	
C42	H8416E8001	Link	1	
C43	H8417E8001	Screw	2	

C.FEEDING AND FEED LIFTING & LOWER SHAFT MECHANISM

Fig. No.	Part No.	Description	Pcs.	Remarks
C44	HA111G0683	Screw	2	SM11/64(40)×12
C45	HA104J6510	Nut	3	SM15/64(28)
C46	H8417B8001	Bushing	1	
C47	H8415E8001	Fixure shaft	1	
C48	HA100C2190	Screw	3	SM11/64(40)×8
C49	H8414E8001	Crank	1	
C50	H005004060	Washer	1	
C51	HA104J6510	Nut	1	SM15/64(28)
C52	H8410E8001	Rocker connecting rod	1	
C53	H8412E8001	Rocker	1	
C54	HA7311CD06	Screw	2	SM9/64(40)×8.5
C55	H8411E8001	Rocker casing	1	
C56	H34411C410	Screw	2	SM9/64(40)×3.5
C57	H0148D8001	Collar	1	
C58	H8422E8001	Large looper shaft	1	
C59	H8421E8001	Shaft	1	
C60	H8420E8001	Bushing	1	
C61	H4940L8001	Nut	1	SM15/64(28)
C62	H8409E8001	Screw	4	SM9/64(40)×6
C63	H8408E8001	Cover	2	
C64	H8419E8001	Eccentric link	1	
C65	H8405E8001	Eccentric	2	
C66	H8406E8001	Screw	4	SM3/16(32)×5
C67	H8407E8001	Eccentric rod	1	
C68	H2009B0072	Hook shaft bushing (left) assy.	1	
C69	H2000E2030	Hook shaft	1	
C70	HA305E0661	Collar	1	
C71	H2009B0751	Hook shaft bushing (right)	1	
C72	H2009B0711	Felt	1	
C73	HA100C2090	Screw	2	
C74	H2000I2080	Screw	1	SM11/64(40)×8.5
C75	HA305G1011	Feed lifting rock shaft crank (left)	1	
C76	HA111G0683	Screw	1	SM11/64(40)×12
C77	HA310G3012	Washer	1	
C78	HA310G3011	Slide block	1	
C79	HA305G1012	Hinge pin for slide block	1	
C80	H8405J8001	Feed lifting rock shaft	1	
C81	HA105D0662	Screw	2	SM1/4(40)×4
C82	HA108G0661	Collar	1	
C83	HA100G2130	Washer	1	
C84	H007009150	Stop ring	1	
C85	HA117G0711	Feed lifting rock shaft crank (right)	1	
C86	HA104G0012	Screw	2	SM3/16(28)×12

D.STITCH REGULATOR MECHANISM

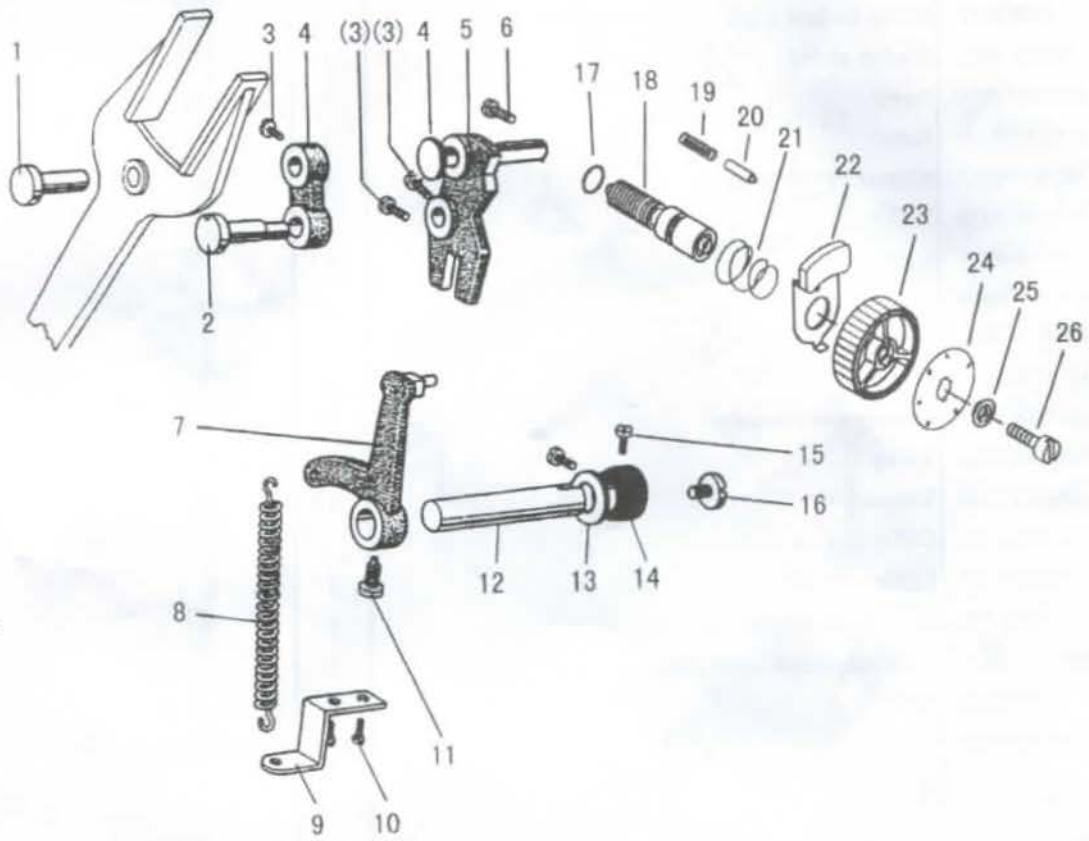

From the library of: Diamond Needle Corp

D.STITCH REGULATOR MECHANISM

Fig. No.	Part No.	Description	Pcs.	Remarks
D01	HA104F0651	Hinge pin	1	
D02	H2006C0024	Hinge pin for feed connecting link	1	
D03	HA104F0654	Screw	3	SM15/64(28)×10
D04	H2006C0661	Feed connecting link	1	
D05	H2006C0662	Feed regulator	1	
D06	HA110D0672	Screw	1	
D07	H2004F0067	Reverse feed crank assy.	1	
D08	H2004F0671	Spring for feed crank	1	
D09	H2000F2030	Bracket spring	1	
D10	HA300C2030	Screw	2	SM11/64(40)×8
D11	HA100F2130	Screw	1	
D12	H2005F0065	Reverse feed lever shaft	1	
D13	HA100F2110	Washer	1	
D14	H8405F8001	Collar	1	
D15	HA104F0654	Screw	2	SM15/64(28)×10
D16	HA113F0683	Screw	1	
D17	HA109F0674	O-ring	1	
D18	HA720F0681	Feed regulator screw bar	1	
D19	HA100F2090	Spring	1	
D20	HA700F2030	Stopper pin	1	
D21	HA720F0687	Coil spring	1	
D22	HA720F0683	Releasing lever	1	
D23	HA7421F120	Dial for stitch length regulator	1	
D24	H7107G8001	Stitch length indicating plate	1	
D25	HA720F0685	Bushing	1	
D26	HA720F0686	Screw	1	SM3/16(28)×18

E.PRESSER FOOT MECHANISM

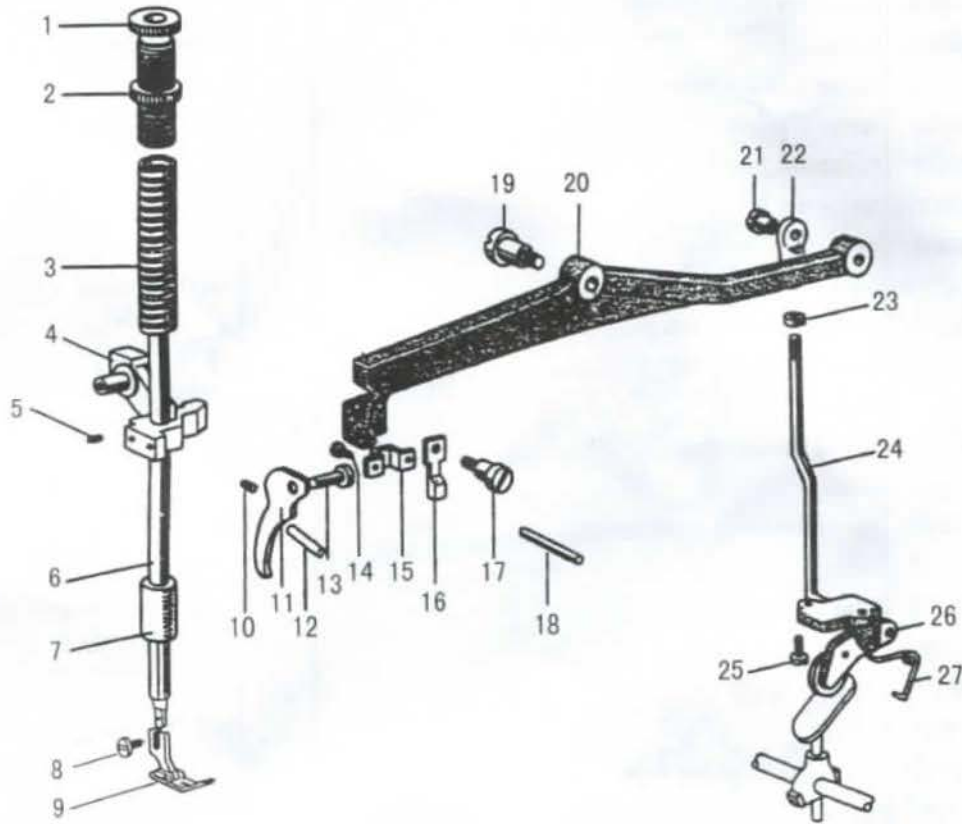

From the library of: Diamond Needle Corp

E.PRESSER FOOT MECHANISM

Fig. No.	Part No.	Description	Pcs.	Remarks
E01	HA309H0681	Pressure regulating thumb screw	1	
E02	HA117H0692	Lock nut	1	
E03	HA300H2050	Presser bar spring	1	
E04	H8410I8001	Presser bar lifting bracket	1	
E05	H4723D8001	Screw	1	SM15/64(28)×4.5
E06	HA300H2110	Presser bar	1	
E07	HA300H2090	Presser bar bushing	1	
E08	HA100H2150	Screw	1	SM9/64(40)×11
E09	H1106H0066	Presser foot complete	1	
E10	H2000I2080	Screw	1	SM11/64(40)×8.5
E11	H2000I2060	Presser bar lifter	1	
E12	H609030180	Spring pin	1	
E13	H2000I2070	Pin	1	
E14	HA300C2030	Screw	2	SM11/64(40)×8
E15	H2000I2100	Presser bar lifting cam guide	1	
E16	H2015I0066	Presser bar lifting cam	1	
E17	H2015I0065	Screw	1	
E18	H2000I2090	Thread tension releasing pin	1	
E19	H2000I2130	Screw	1	
E20	H2015I0067	Knee lifter lifting lever	1	
E21	H2000I2140	Screw	1	
E22	H2000I2150	Connecting rod joint	1	
E23	H2000I2160	Nut	1	
E24	H2000I2170	Connecting rod	1	
E25	H2000I2200	Screw	2	SM11/64(40)×12
E26	H2000I2180	Knee lifter bell crank assy.	1	
E27	H2000I2190	Spring for knee lifter bell crank	1	

F.OIL LUBRICATION MECHANISM

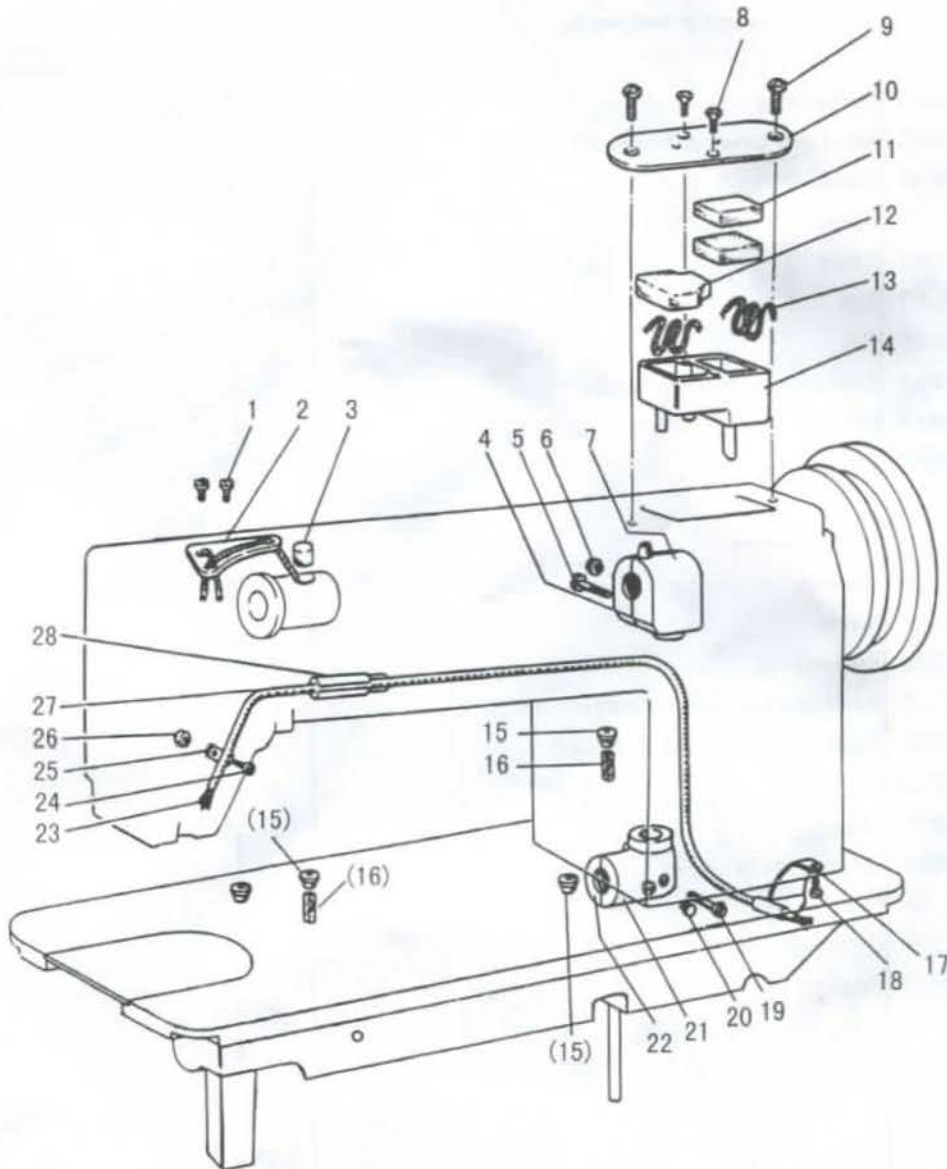

From the library of: Diamond Needle Corp

F.OIL LUBRICATION MECHANISM

Fig. No.	Part No.	Description	Pcs.	Remarks
F01	HA100H2150	Screw	2	SM9/64(40)×11
F02	H2000M0010	Oil pump body	1	
F03	H2009B0743	Felt	1	
F04	H2017M0067	Bevel gear cover(up-backward)	1	
F05	H409050140	Screw	1	
F06	HA300B2110	Rubber plug	1	
F07	H2017M0065	Bevel gear cover(up-forward)	1	
F08	HA06030080	Screw	2	
F09	HA300B2170	Screw	2	
F10	H2020M0065	Cover	1	
F11	H2020M0067	Felt	2	
F12	H2020M0069	Felt	1	
F13	H2020M0068	Oil wick	2	
F14	H2020M0066	Oil case	1	
F15	H2000M0090	Oil cup	4	
F16	H2000M0080	Felt	2	
F17	H2000M0130	Oil pipe holder	1	
F18	HA300C2030	Screw	1	SM11/64(40)×8
F19	H409050140	Screw	1	
F20	HA300B2110	Rubber plug	1	
F21	H2018M0065	Bevel gear cover(lower-forward)	1	
F22	H2018M0066	Bevel gear cover(lower-backward)	1	
F23	H2013M0066	Oil wick	3	
F24	H2000I2200	Screw	1	SM11/64(40)×12
F25	H2000M0110	Oil pipe holder	1	
F26	H2000M0120	Nut	1	
F27	H2009B0070	Oil pipe holder	1	
F28	H2013M0065	Oil pipe	1	

G.ACCESSORIES

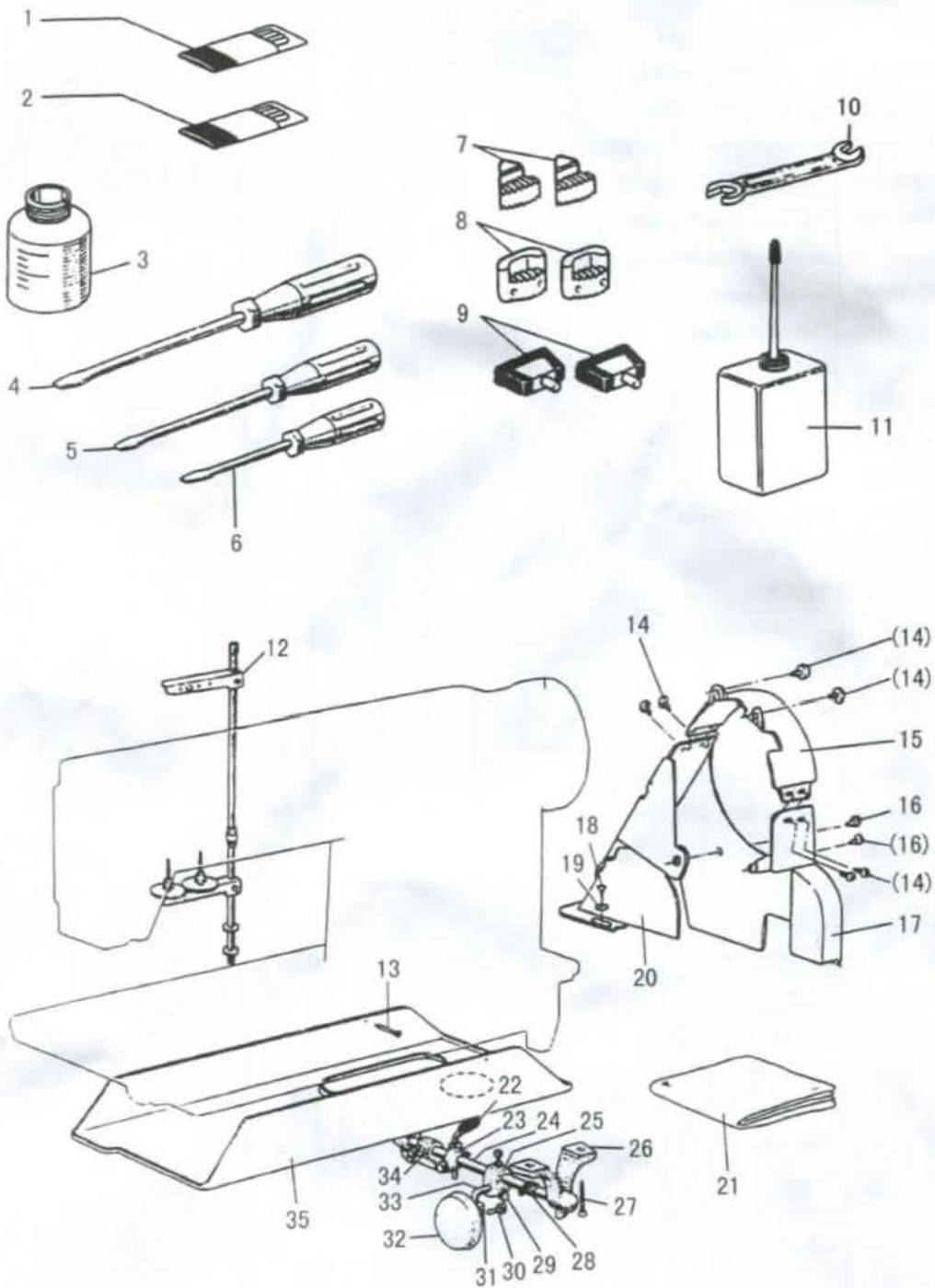

From the library of: Diamond Needle Corp

G.ACCESSORIES

Fig. No.	Part No.	Description	Pcs.	Remarks
G01	H2404D0653	Needle	4	DP×5#16
G02	H8406G8001	Hook needle	4	CP×170#16
G03	HA600J2030	Oiler	1	
G04	HA300J2070	Screw driver(large)	1	
G05	HA300J2200	Screw driver(middle)	1	
G06	HA300J2210	Screw driver(small)	1	
G07	H2004O0066	Vibration preventing rubber	2	
G08	H2004O0065	Vibration preventing rubber	2	
G09	HA307J0067	Table hinge with rubber cushion	2	
G10	HA300J2220	Double-ended spanner	1	
G11	H2004O0069	Oil with oiler	1	
G12	HA200J2030	Thread stand assy.	1	
G13	HZB1016250	Nail	10	
G14	H2000O0360	Screw	6	SM11/64(40)×6
G15	H2000O0330	Belt cover(up)	1	
G16	HA300J2280	Screw	2	SM15/64(28)×8
G17	H2000O0340	Belt cover(down)	1	
G18	H801045200	Wood screw	2	4.5×20
G19	HA300J2230	Washer	2	
G20	H1200H0070	Belt cover(down)	1	
G21	HA300J2190	Cover	1	
G22	H2015O0071	Crank assy.	1	
G23	H2015O0069	Joint	1	
G24	H2015O0066	Hinge pin for knee lifter	1	
G25	HA106J0663	Joint for knee lifter bell crank	1	
G26	H2015O0065	Hinge bracket for knee lifter	2	
G27	H802045250	Wood screw	4	
G28	H2015O0070	Backspring for knee lifter	1	
G29	HA300J2180	Set screw	5	
G30	HA106J0667	Screw	1	SM15/64(28)×8
G31	HA106J0666	Bracket for knee lifter plate	1	
G32	HA106J0668	Pad for knee lifter plate	1	
G33	HA106J0662	Knee lifter bell crank	1	
G34	H2015O0067	Knee lifter stop bracket	1	
G35	H2000O0020	Oil pan assy.	1	