

Purchasing Dept
Copy



HIGHLEAD

GG0068-1

High-Speed, 1-Needle, Lockstitch, Zigzag Stitching Machine

Instruction Manual
Parts Catalog

From the library of: Diamond Needle Corp

SHANGHAI HUIGONG NO.3 SEWING MACHINE FACTORY

CONTENTS

CONTENTS.....	1
1、 PRECAUTIONS BEFORE STARTING OPERATION.....	2
2、 MAIN SPECIFICATIONS.....	2
3、 PREPARATION AND LUBRICATION.....	2
4、 REPLACE NEEDLES.....	3
5、 WINDING THE BOBBIN THREAD.....	3
6、 THREADING THE MACHINE HEAD	4
7、 ADJUSTING THE STITCH LENGTH.....	5
8、 ADJUSTING THE HEIGHT OF THE PRESSER	5
9、 ADJUSTING THE PRESSURE OF THE PRESSER FOOT.....	5
10、 ADJUSTING THE THREAD TENSION	5
11、 ADJUSTING THE BOBBIN THREAD TENSION.....	6
12、 ADJUST THE ZIGZAG WIDTH	6
13、 ADJUSTING THE DENSER STITCHING	7
14、 ATTACHING / REMOVING THE HOOK	7
15、 ADJUST THE POSITION OF FEED DOG	7
16、 ADJUSTING HEIGHT OF THE NEEDLE BAR	8
17、 ADJUSTING THE NEEDLE TO HOOK TIMING AND THE NEEDLE GUARD	8
18、 ADJUSTING THE AMOUNT OF OIL IN THE HOOK.....	8
19、 CHANGE OVER OF STANDARD ZIGZAG	9
20、 PLACING A BOBBIN INTO THE BOBBIN CASE.....	9
PARTS CATALOG.....	10

1. PRECAUTIONS BEFORE STARTING OPERATION

1) Safety Precautions

- (1) When turning the power on, keep your hands and fingers away from the area around/under the needle and the area around the balance wheel.
- (2) Power must be turned off when the machine is not in use, or when the operator leaves the seat.
- (3) Power must be turned off when tilting the machine head, installing or removing the "V" belt, adjusting the machine, or when replacing.
- (4) Avoid placing fingers, hairs, bars etc., near the balance wheel, "V" belt, bobbin winder balance wheel, or motor when the machine is in operation.
- (5) Do not insert fingers into the thread take-up cover, under/around the needle, or balance wheel when the machine is in operation.
- (6) If a belt cover, finger guard, eye guard are installed, do not operate the machine without these safety devices.

2) Precautions before Starting Operation:

- (1) If the machine's oil pan has an oil sump, never operate the machine before filling it.
- (2) If the machine is lubricated by a drop oiler, never operate the machine before lubricating.
- (3) When a new sewing machine is first turned on, verify the rotational direction of the balance wheel with the power on. (The balance wheel should rotate counter-clockwise when viewed from the balance wheel)
- (4) Verify the voltage and (single or three) phase with those given on the machine nameplate.

3) Precautions for Operating Conditions:

- (1) Avoid using the machine at abnormally high temperature (35°C or higher) or low temperature (5°C or lower) .
- (2) Avoid using the machine in dusty conditions.

2. MAIN SPECIFICATIONS

Specs \ Model		2-step	4-step
Max.sewing speed		4500 rpm	
Feed pitch		2.5mm	2 mm
Zigzag width		5mm	10 mm (Standard 8 mm)
Presser	By hand	5.5mm	
	By knee	10mm	
Needle		DP×5 9#—14#	
Rotating hook		Auto lubricated hook	
Lubrication		Auto lubricated	
Motor		370W clutch motor	

3. PREPARATION AND LUBRICATION

1) Cleaning the machine

Before leaving the factory, the machine parts are coated with rust-preventive grease, which may be hardened and contaminated by dust during storage and shipment. This grease must be removed with gasoline.

2) Examination

Though every machine is confirmed by strict inspection and test before leaving the factory, the machine parts may be loose or deformed after long distance transportation with jolt. A thorough examination must be performed after cleaning the machine. Turn the balance wheel to see if there is running obstruction, parts collision, uneven resistance or abnormal noise. If these exist, adjustment must be made accordingly before run-in operation.

3) Oiling (Fig.1)

(1) Required amount of oil

Line (A) on the oil reservoir: Max. Oil level

Line (B) on the oil reservoir: Min. Oil level

If oil level goes down under line B, oil cannot be distributed to each part of the machine, thus causing the parts a seizure.

(2) Replenishing

Always use only No. 18 special machine oil for high speed sewing. Be sure to replenish oil to line A before starting operation.

(3) Replacing oil

To replace oil, remove screw (C) to drain oil. After completely draining off oil, clean the oil reservoir and securely tighten screw (C), then fill the reservoir with fresh oil.

4. REPLACE NEEDLES (Fig.2)

Turn the handwheel by hand to raise the needle bar to the highest point. Loosen the needle clamp screw ①, hold the needle ② so that the long groove B on the needle is facing exactly toward you. Insert the needle deep into the hole of the needle bar in the direction of the arrow until it will go no further. Securely tighten the screw ①.

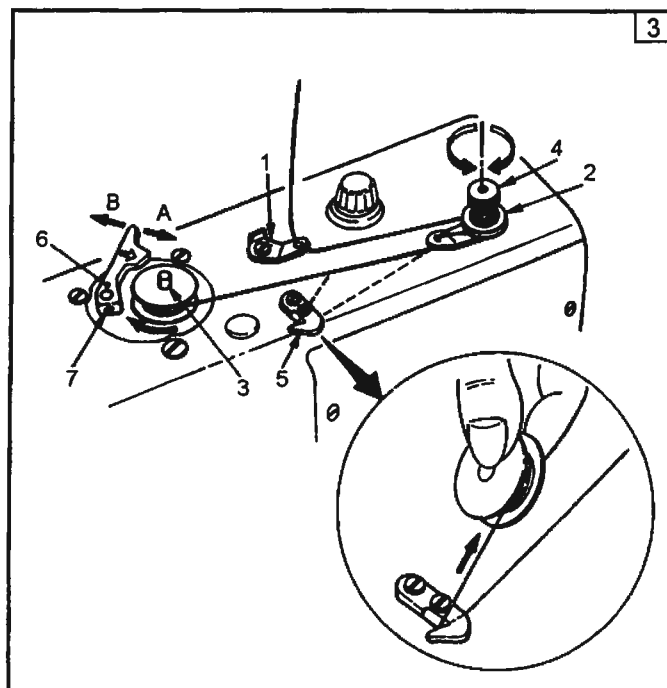
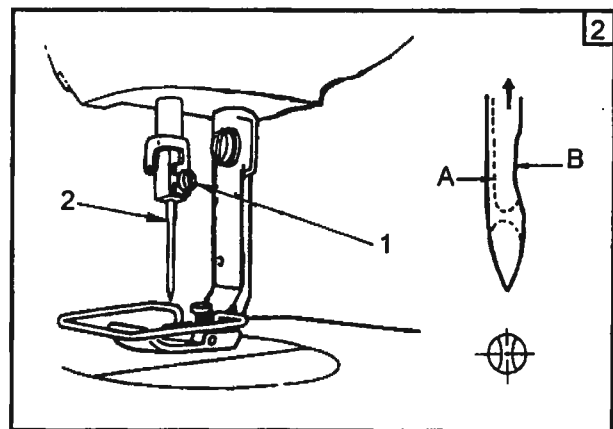
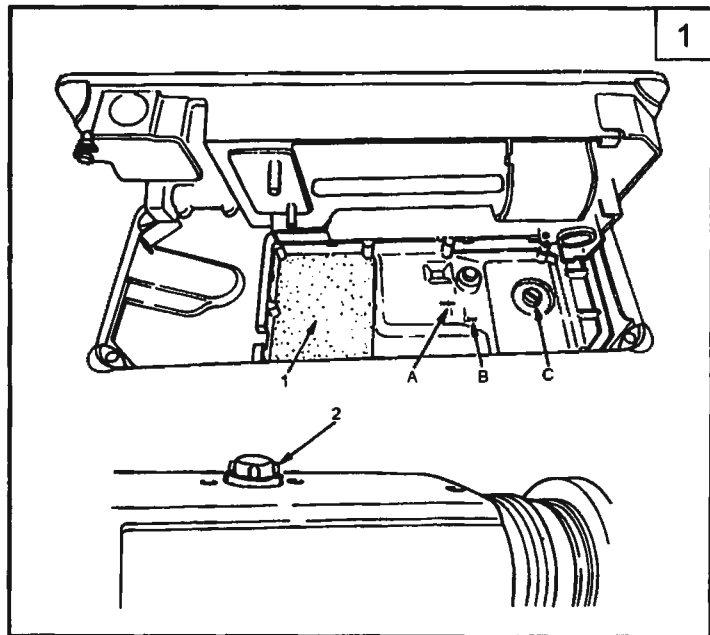

5. WINDING THE BOBBIN THREAD (Fig.3, 4)

1) Insert the bobbin deep into the bobbin winder spindle ③ until will go no further.

2) Pass the bobbin thread pulled out from the spool rested on the right side of the thread stand following the order as shown in the figure on the left. Then, wind the end of the bobbin thread on the bobbin several times.

3) Press the bobbin winder trip latch ⑥ in the direction of A and start the sewing machine. The bobbin rotates in the direction of C and the bobbin thread is wound up. The bobbin winder spindle ③ will automatically stop as soon as the winding is finished.

4) Remove the bobbin and cut the bobbin thread with the thread cut retainer ⑤.

5) To adjust the winding amount of the bobbin thread, loosen the setscrew ⑦ and move the bobbin winder trip latch ⑥ to the direction A or B. Then, tighten the setscrew.

To the direction A: Decrease; To the direction B : Increase.

6) In case that the bobbin thread is not wound evenly on the bobbin , loosen the nut ⑧ and turn the bobbin thread tension to adjust the height of the thread tension disk ②.

It is the standard that the center of the bobbin is as high as the center of the thread tension disk.

Move the position of the thread tension disk ② to the direction A as shown in the figure on the left when the winding amount of the bobbin thread on the lower part of the bobbin is excessive and to the direction B as shown in the figure on the left when the winding amount of the bobbin thread on the upper part of the bobbin is excessive. After the adjustment, tighten the cut ⑧.

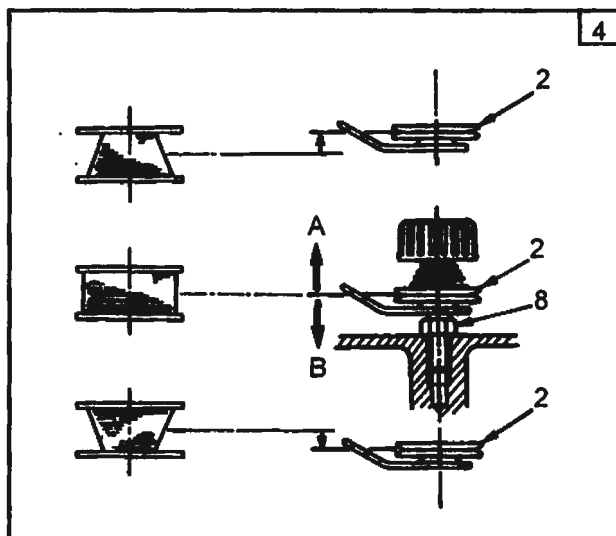

6. THREADING THE MACHINE HEAD (Fig. 5)

Turn the handwheel by hand to raise the needle to the highest point. Pass the thread in the order of the

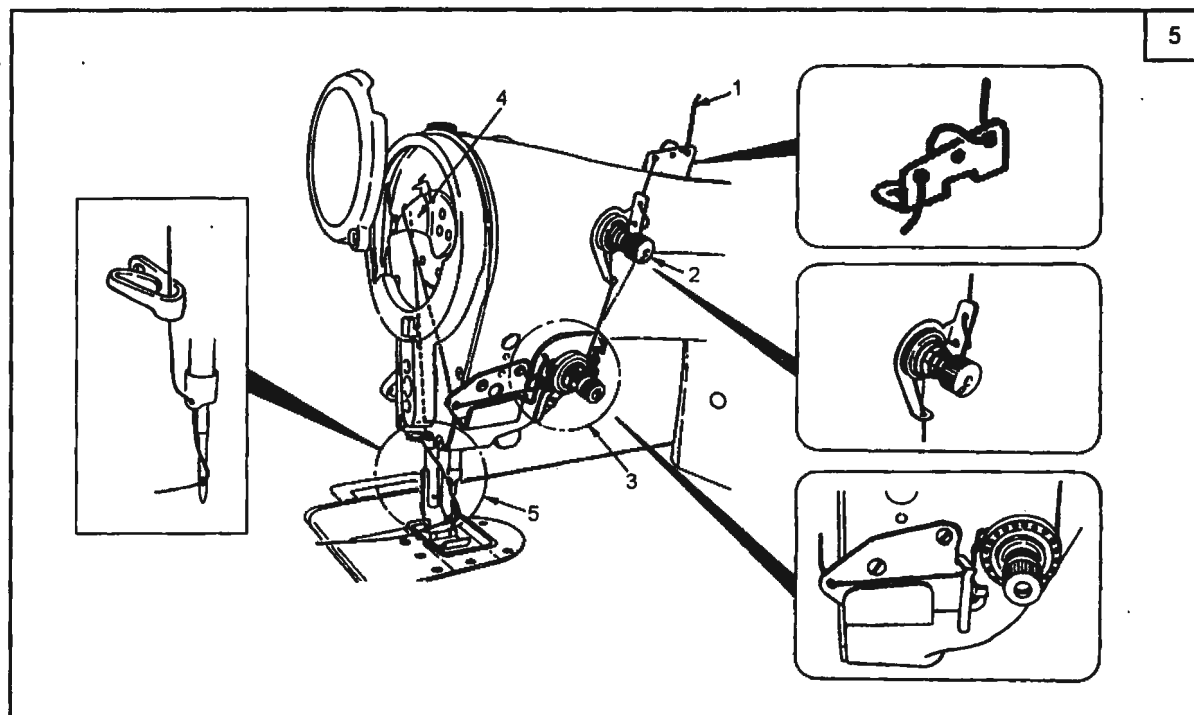

numbers as illustrated.

7、 ADJUSTING THE STITCH LENGTH (Fig. 6)

1) Adjusting the stitch, turn the stitch length dial A in the direction of the arrow so that the number corresponding to the desired stitch length meets the marker dot B engraved on the machine arm. (Number on the stitch length dial are calibrated in "mm".)

2) To perform reverse feed stitching, press down the feed lever C. The sewing machine performs reverse feed stitching as long as you keep the feed lever held pressed. The feed lever will return to its home position and the sewing machine will run in the normal stitching direction when you release the feed lever.

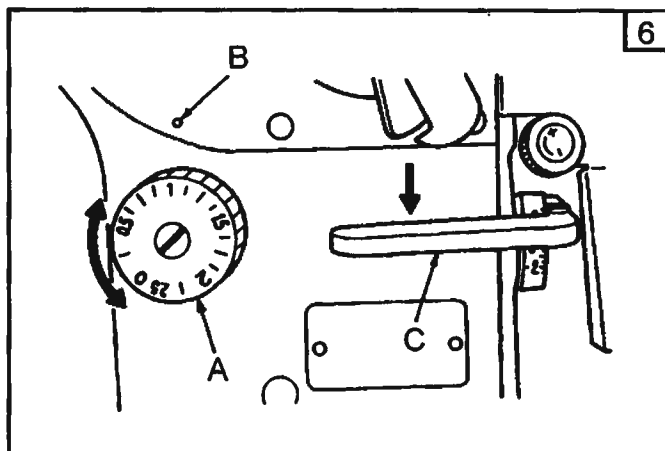

8、 ADJUSTING THE HEIGHT OF THE PRESSER (Fig. 7)

To change the height of the presser bar or the inclination of the presser foot, loosen the presser bar connection screw ① and perform the adjustment properly. After the adjustment, securely tighten the screw.

9、 ADJUSTING THE PRESSURE OF THE PRESSER FOOT (Fig.8)

Pressure of presser foot is to be adjusted in accordance with thickness of materials to be sewn. First loosen lock nut 1, turn the presser spring regulator 2 clockwise A to increase the pressure given by the presser foot; turn the presser spring regulator counterclockwise B to decrease it. Then tighten lock nut 1.

The pressure of presser foot is recommended to be less as long as normal feeding is ensured.

10、 ADJUSTING THE THREAD TENSION (Fig.9, 10)

1) Adjusting the needle thread tension (Fig.9)

Adjust the needle thread tension using the tension nut 4. Turning the tension nut clockwise increases the needle thread tension, or counterclockwise decreases it.

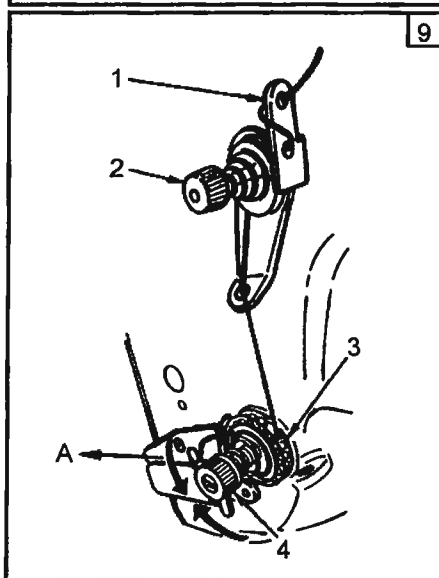
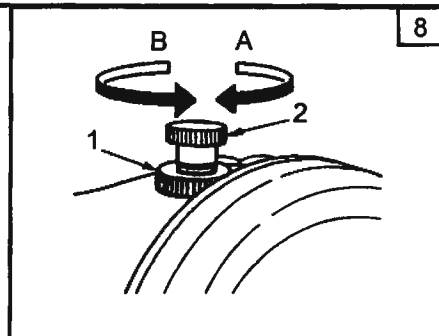
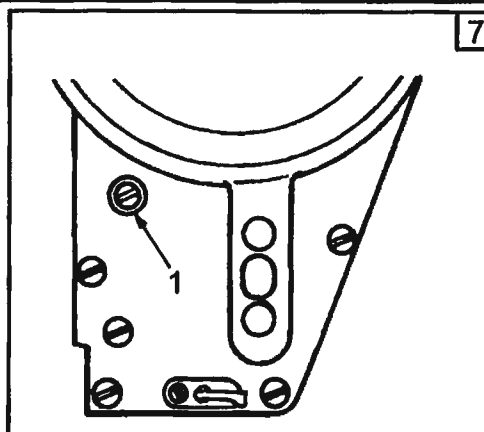

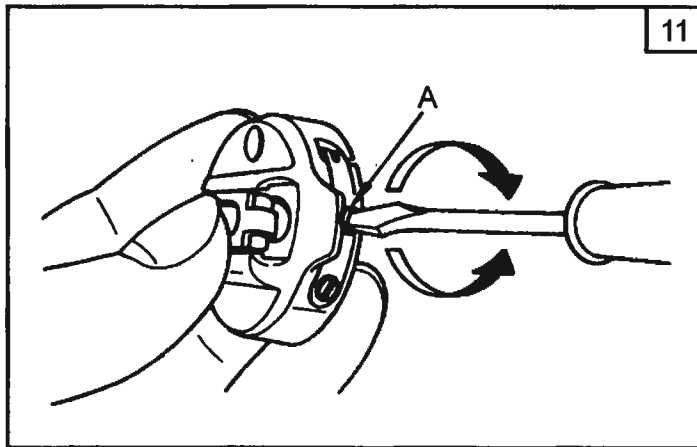
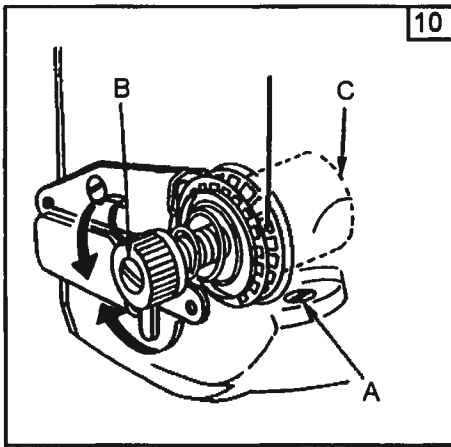

2) Adjusting the thread take-up spring (Fig.10)

To change the tension of the thread take-up spring, firmly tighten the screw A which fastens the tension post socket to the machine arm and insert the blade of a screwdriver into the slot in the tension post B to adjust the tension of the thread take-up spring.

3) Adjusting the thread take-up spring stroke (Fig. 10)

Loosen the clamping screw A of the tension post socket and turn the tension post socket C.

Adjustable range of the amount of thread taken by the thread take-up spring.....6 to 10 mm.

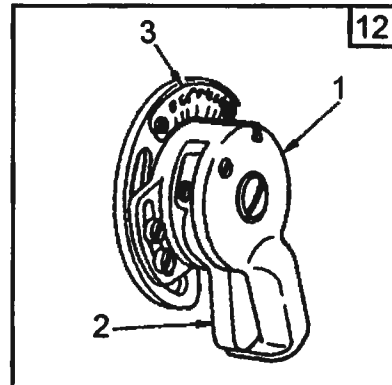

11. ADJUSTING THE BOBBIN

THREAD TENSION (Fig.11)

The tension of the bobbin thread is adjusted by turning the tension adjusting screw A.

Turn it clockwise to increase.

Turn it counterclockwise to decrease.

It is common practice to test the bobbin thread tension as shown in Fig.11. Hold the end of the thread from delivery eye. If the bobbin case is falling slowly, the proper tension is obtained. The

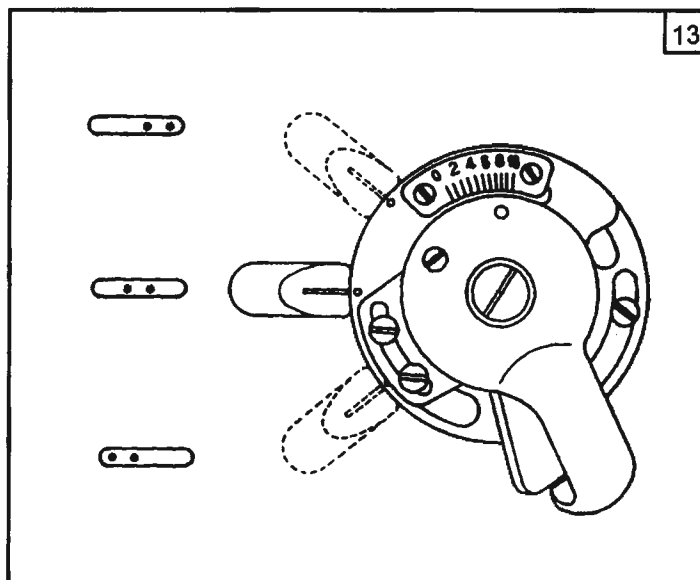

needle thread tension can be adjusted by setting (1) the take-up spring tension, (2) the thread take-up spring stroke and (3) tension spring. All these adjustments will be described in the following.

12. ADJUST THE ZIGZAG WIDTH (Fig.12, 13)

1) Adjust the zigzag width

The zigzag width is adjusted by the knob ①.

2) Changing the needle position

when changing the position of needle entry, move the needle position changing lever as shown in the figure13.

13. ADJUSTING THE DENSER STITCHING

(Fig.14)

Stitch length can be reduced at the start or end of sewing. This feature is used for fastening stitch.

1) If you turn the dial with the feed lever held pressed down, the feed lever will move. Adjust the stitch length for denser stitching taking the graduation which meets the top surface of the feed lever as reference;

2) Turn the dial in the "+" direction to reduce the reverse feed stitch length. "+2" means "normal feed stitch length is 2mm" and "-2" means "reverse feed stitch length is 2mm".

Advert: The graduations on the dial are mere reference. So adjust the denser stitching while actually observing the finished seam.

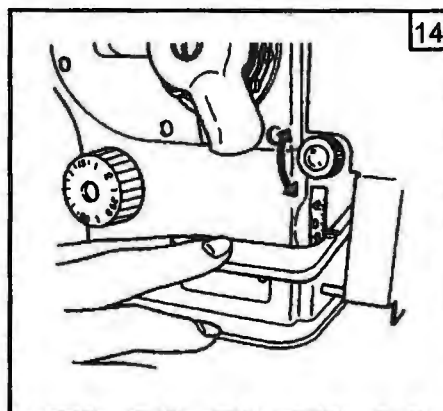

14. ATTACHING / REMOVING THE HOOK

(Fig.15)

When you replace the sewing hook, remove it in the following procedures:

1) Turn the handwheel until the needle reaches to its highest position ;

2) Remove the needle, presser foot, throat plate, feed dog and bobbin case from the machine;

3) Remove the setscrew 1 and take out the bobbin case positioning finger 2;

4) Loosen the two screws 4 and remove the sewing hook.

Reverse the above procedures when inserting the sewing hook. Advert: At this time, make sure that top end A of the bobbin case positioning finger is aligned with line B. as shown in the figure 15. Never let A protrude from line B.

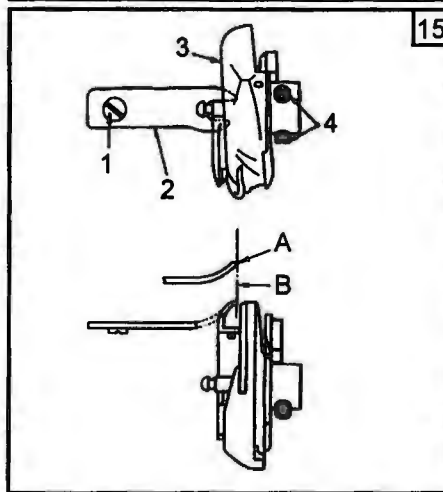

15. ADJUST THE POSITION OF

FEED DOG (Fig.16)

To adjust the height of the feed dog

1) Loosen the screw 1 and turn the feed driving link pin 2 using a screwdriver;

2) The standard height of the feed dog is 1.2mm.

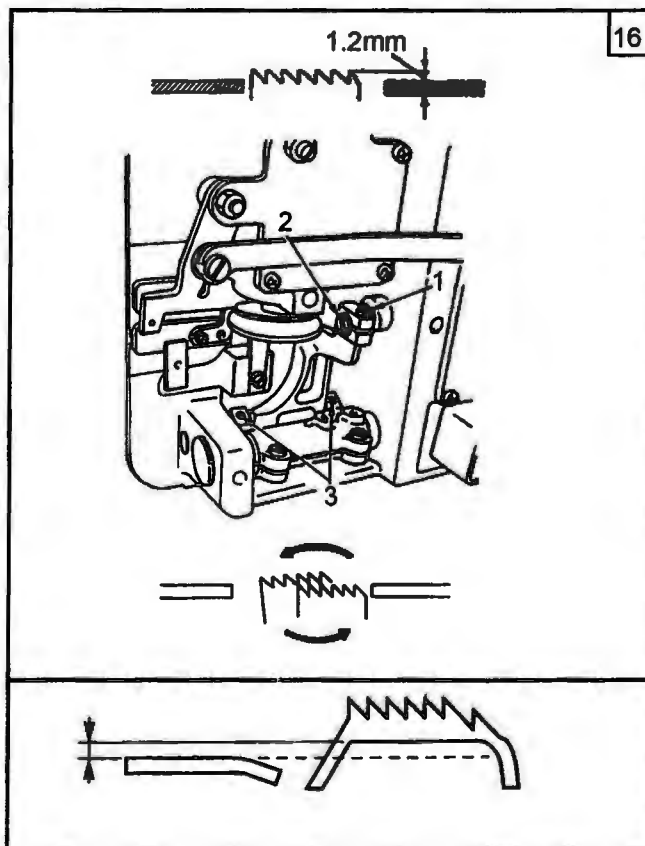

Inclination of the feed dog (The standard inclination of the feed dog is obtained by adjusting the feed dog so that it becomes horizontal when it rises above the top surface of the throat plate).

16. ADJUSTING HEIGHT OF THE NEEDLE BAR (Fig.17)

1) Set the zigzag width to "0". Bring the needle to the center of zigzag stroke;

2) Remove the presser foot, throat plate, semicircle plate and feed dog;

3) Place the semicircle plate A on the plane, to which the throat plate is to be attached, of the bed. Loosen the screw ①, and adjust so that a height difference of timing gauge 1 is provided between the lowest end of the needle bar and the top surface of the semicircle plate.

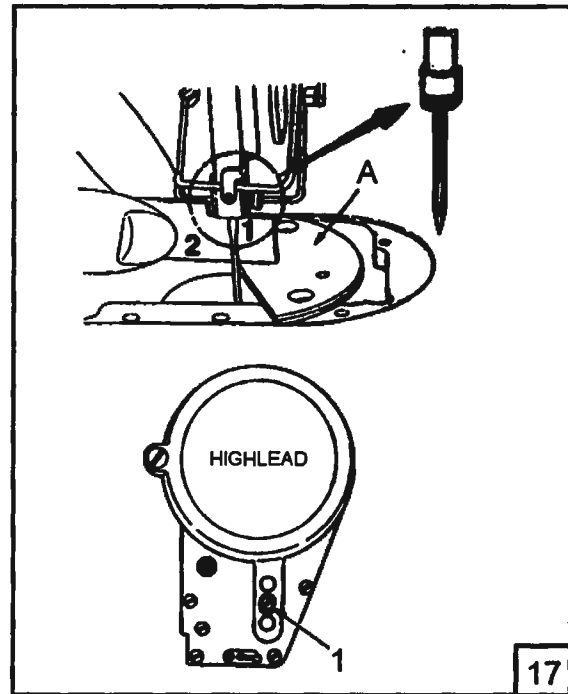

17. ADJUSTING THE NEEDLE TO HOOK TIMING AND THE NEEDLE GUARD (Fig.18, 19)

(Fig.18, 19)

1) **Positioning the hook:** ①After the completion of the adjustment of the needle bar height, adjust the hook using gauge 2 so that the blade point of the hook is aligned with the center of the needle. ②Confirmation: maximize the zigzag width, bring the needle to the leftmost position of the zigzag stroke. Now, confirm that the top end of the needle eyelet is spaced 0.2-0.5mm away from the blade point of the hook.

2) **Adjusting the needle guard:** ①Maximize the zigzag width. Bend the needle guard to adjust so that the needle does not come in contact with the blade point of the both at

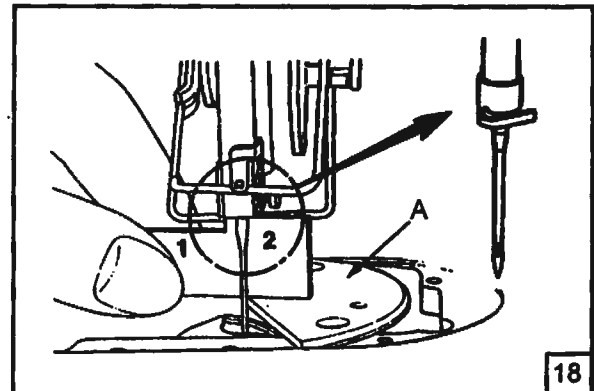

the leftmost and rightmost positions of the zigzag stroke. At this time, adjust the clearance provided between the needle and the blade point of the hook to 0 to 0.05 mm. ②The needle guard functions to keep the needle away from the blade point of the hook, thereby preventing damage to the blade point of the hook. Whenever you have replaced the hook with a new one, be sure to adjust the position of the needle guard.

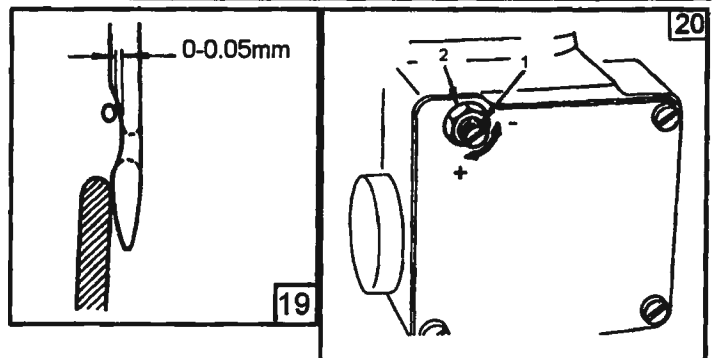

18. ADJUSTING THE AMOUNT OF OIL IN THE HOOK (Fig.20)

1) Tilt machine head, and adjust the amount of oil in the hook by turning the adjusting screw ① mounted on the hook driving shaft dear box. Loosen the nut ②, then turn the adjusting screw ①.

2) After the adjustment, fix the adjusting screw by tightening the nut ②.

19、 CHANGEOVER OF STANDARD ZIGZAG (Fig.21)

- 1) Turn handwheel by hand to bring needle to its lowest position;
- 2) Pull changeover lever 1 toward this side and pull out lock pin 2 from positioning hole 3;
- 3) Turn changeover lever 1 while pulling it and adjust it to zigzag mark 4 you desire. At this time, securely place lock pin 2 in positioning hole 3 and set it;
- 4) When changeover lever 1 cannot be turned, perform again the work of steps 1) to 3) after manually turning the handwheel by one turn (360°). Perform repeatedly until changeover work can be completed.

Caution: Never operate the sewing machine in the state that lock pin 2 is not placed in positioning hole 3 (on the way of changeover). It will cause the trouble of the sewing machine.

20、 PLACING A BOBBIN INTO THE BOBBIN CASE (Fig.22)

- 1) Take a bobbin by your right hand with the thread drawn out about 5 cm and place it into the bobbin case as illustrated;
- 2) Thread the bobbin case in the order of the numbers and pull it out through the thread path as illustrated;
- 3) Make sure that the bobbin rotates in the bobbin case in the direction shown by arrow.

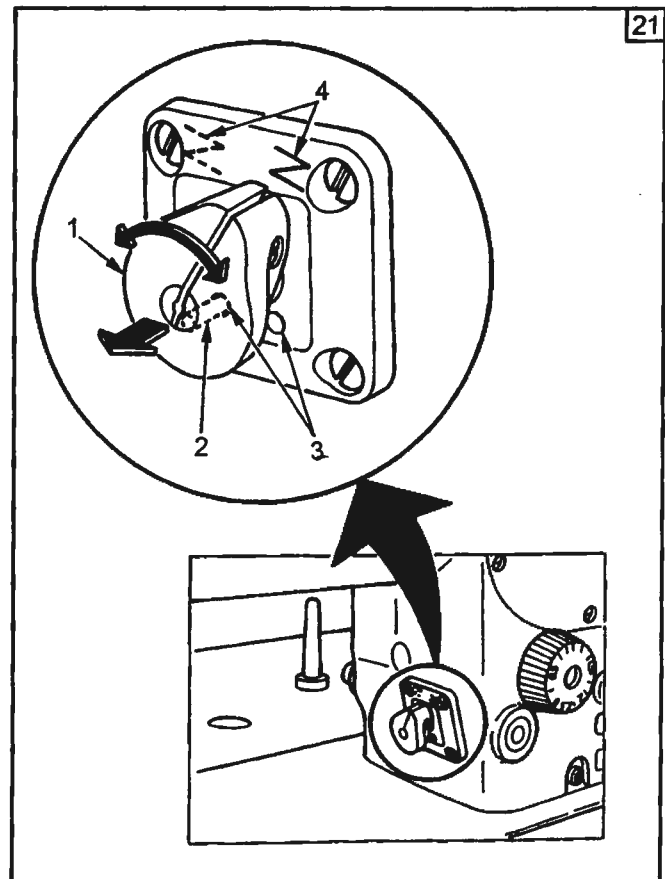
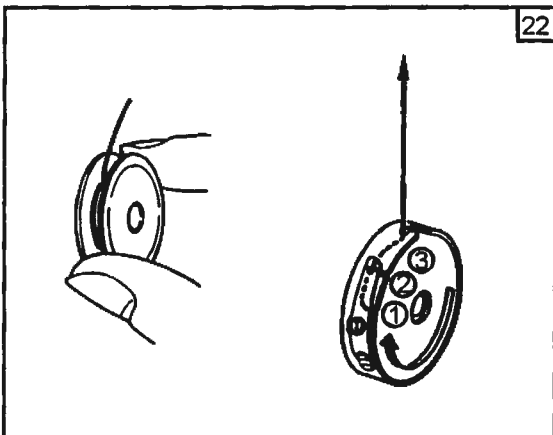

A.ARM BED AND IT'S ACCESSORIES(1)

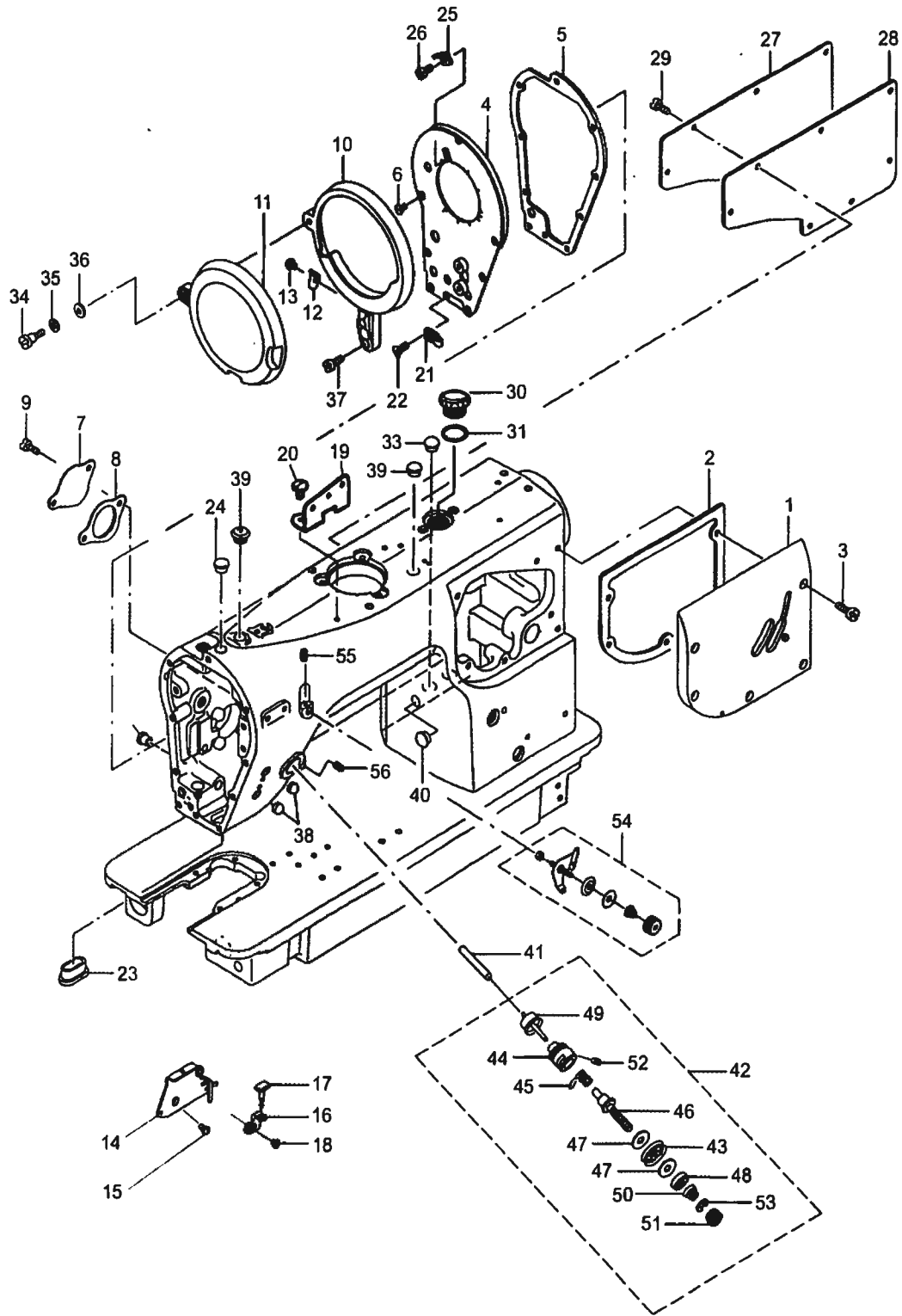

From the library of: Diamond Needle Corp

A.ARM BED AND IT'S ACCESSORIES(1)

Fig. No.	Part No.	Description	Qty.	Remarks
A01	HK317B8001	Arm side cover	1	
A02	HK318B8001	Gasket	1	
A03	HK319B8001	Screw	5	11/64 (40) × 14
A04	HK321B7101	Face olate assy.	1	
A05	HK323B8001	Gasket	1	
A06	H5715B8001	Screw	7	11/64 (40) × 8
A07	HK325B8001	Tension release window plate	1	
A08	HK326B8001	Gasket	1	
A09	HA300C2030	Screw	2	11/64 (40) × 8
A10	HK328B8001	Balance cover base	1	
A11	HK329B7101	Balance cover	1	
A12	HK331B8001	Spring	1	
A13	HK332B8001	Screw	1	3/16 (28) × 6
A14	HK334B8001	Balance thread guide	1	
A15	H5715B8001	Screw	2	11/64 (40) × 8
A16	HK336B8001	Spring guard	1	
A17	HK337B8001	Rubber plug	1	
A18	HK338B8001	Screw	1	9/64 (40) × 3.5
A19	HA700B2050	Thread guide	1	
A20	HA700B2060	Screw	1	
A21	HK340B8001	Thread guide	1	
A22	H3000D2160	Screw	1	9/64 (40) × 7
A23	HK342B8001	Arm oil shield	1	
A24	HA100F2070	Rubber plug	1	
A25	HK344B8001	Take-up thread cutter	1	
A26	H5727B8001	Screw	1	1/8 (44) × 3.8
A27	HK347B8001	Side plate	1	
A28	HK348B8001	Gasket	1	
A29	HA300H2170	Screw	8	11/64 (40) × 9
A30	H1210B0671	Oil sight window	1	
A31	H1210B0672	Rubber ring	1	
A32	HA100C2110	Rubber plug	1	
A33	HA100F2070	Rubber plug	2	
A34	HK355B8001	High screw	1	
A35	HK356B8001	Waved washer	1	GB/T955 6
A36	H005004060	Washer	1	
A37	HA300B2160	Screw	2	11/64 (40) × 9
A38	HK359B8001	Rubber plug	2	
A39	H3200B2190	Rubber plug	2	
A40	HA100F2070	Rubber plug	1	
A41	HK362B8001	Thread release	1	
A42	HK363B7101	Thread tension assy.	1	
A43	HK364B8001	Thread tension disk compl.	1	

A.ARM BED AND IT'S ACCESSORIES(1)

Fig. No.	Part No.	Description	Qty.	Remarks
A44	HK33BB8001	Thread tension rod assy.	1	
A45	HA115B0706	Take-up spring	1	
A46	HA115B0701	Screw	1	
A47	HK368B8001	Felt	2	
A48	HA310B0702	Tension disc holder	1	
A49	HK33CB7101	Tension release pin assy.	1	
A50	HA115B0703	Tension spring	1	
A51	HA115B0702	Tension nut	1	
A52	HA711B0681	Screw	1	9/64 (40) × 4.5
A53	HA115B7010	Rotating stopper	1	
A54	HK33HB7101	Pre-tension controller assy.	1	
A55	HA100B2110	Screw	1	
A56	HA300B2080	Screw	1	15/64 (28) × 6.5

B.ARM BED AND IT'S ACCESSORIES(2)

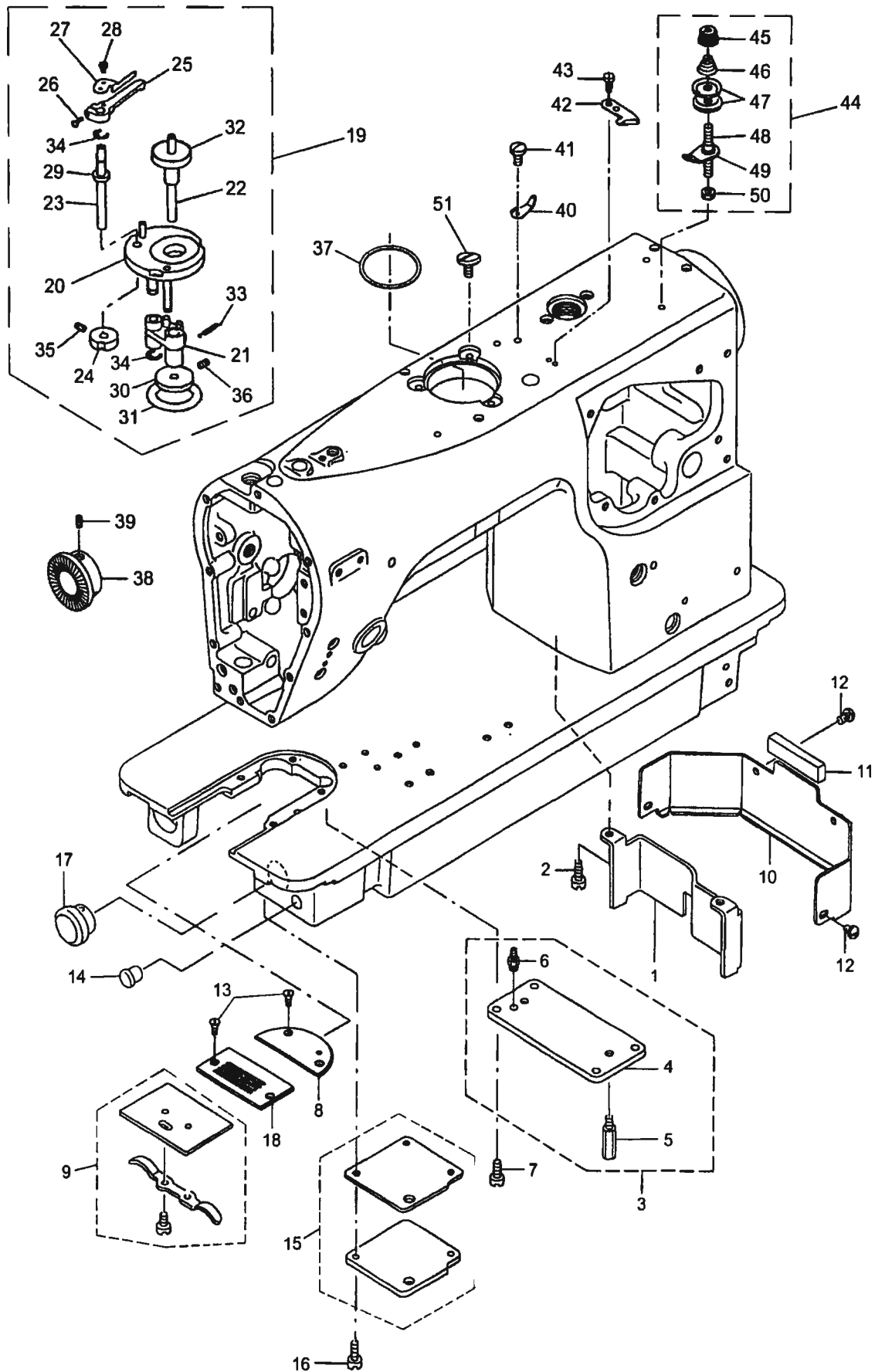

From the library of: Diamond Needle Corp

B.ARM BED AND IT'S ACCESSORIES(2)

Fig. No.	Part No.	Description	Qty.	Remarks
B01	HK374B8001	Support plate	1	
B02	HA300B2160	Screw	2	11/64 (40) × 10
B03	HK376B7101	Helical gear box cover assy.	1	
B04	HK377B8001	Helical gear box cover	1	
B05	HK378B8001	Bed screw stud	2	
B06	HK380B8001	Connecting screw	1	
B07	HA100B2060	Screw	4	11/64 (40) × 9
B08	HK383B8001	Bed plate	1	
B09	HK384B7101	Bed slide assy.	1	
B10	HK388B8001	Oil shield plate	1	
B11	HK389B8001	Oil shield rubber	1	
B12	H200000360	Screw	2	11/64 (40) × 5
B13	HA300B2190	Screw	4	11/64 (40) × 4.5
B14	HK359B8001	Rubber plug	1	
B15	HK391B7101	Helical bevel gear box cover assy.	1	
B16	HA300B2160	Screw	3	11/64 (40) × 9
B17	HK395B8001	Nylon cap	1	
B18	HK397B8001	Needle plate	1	
B19	HK398B7101	Bobbin device assy.	1	
B20	HK399B7101	Bobbin fitting basis assy.	1	
B21	HK30BB7101	Bobbin brace assy.	1	
B22	HK30EB8001	Bobbin shaft	1	
B23	HK30FB8001	Bobbin cam shaft	1	
B24	HK33AB8001	Bobbin cam	1	
B25	H6720N8001	Bobbin lever	1	
B26	HA100H2150	Screw	1	
B27	H6721N8001	Adjust plate	1	
B28	H3200B2100	Scrw	1	
B29	H6722N8001	Washer	2	
B30	H7214J8001	Bobbin winder wheel	1	
B31	H7331D8001	Rubber ring	1	
B32	H6717N8001	Cushion	1	
B33	H6724N8001	Spring	1	
B34	H007013050	E-ring	2	
B35	H431050050	Screw	1	M5 × 5
B36	H431030040	Screw	2	M3 × 4
B37	HK31GB8001	Gasket	1	
B38	HK31HB8001	Bobbin winder wheel	1	
B39	H5312D8001	Screw	2	1/4 (40) × 6
B40	HK31IB8001	Thread guide	1	
B11	HK31JB8001	Screw	1	11/64 (40) × 5
B12	H6756B8001	Thread cutter	1	
B13	H6762B8001	Screw	2	

B.ARM BED AND IT'S ACCESSORIES(2)

Fig. No.	Part No.	Description	Qty.	Remarks
B44	HK32AB7101	Bobbin thread tension assy.	1	
B45	HA710B0671	Bobbin thread nut	1	
B46	HK33IB8001	Bobbin thread soring	1	
B47	HA112B0693	Bobbin winder thread disc	2	
B48	H4206B0661	Bobbin thread screw	1	
B49	HK31IB8001	Thread guide	1	
B50	H5729F8001	Nut	1	11/64 (40)
B51	H3107G0662	Screw	3	

C. UP SHAFT MECHANISM

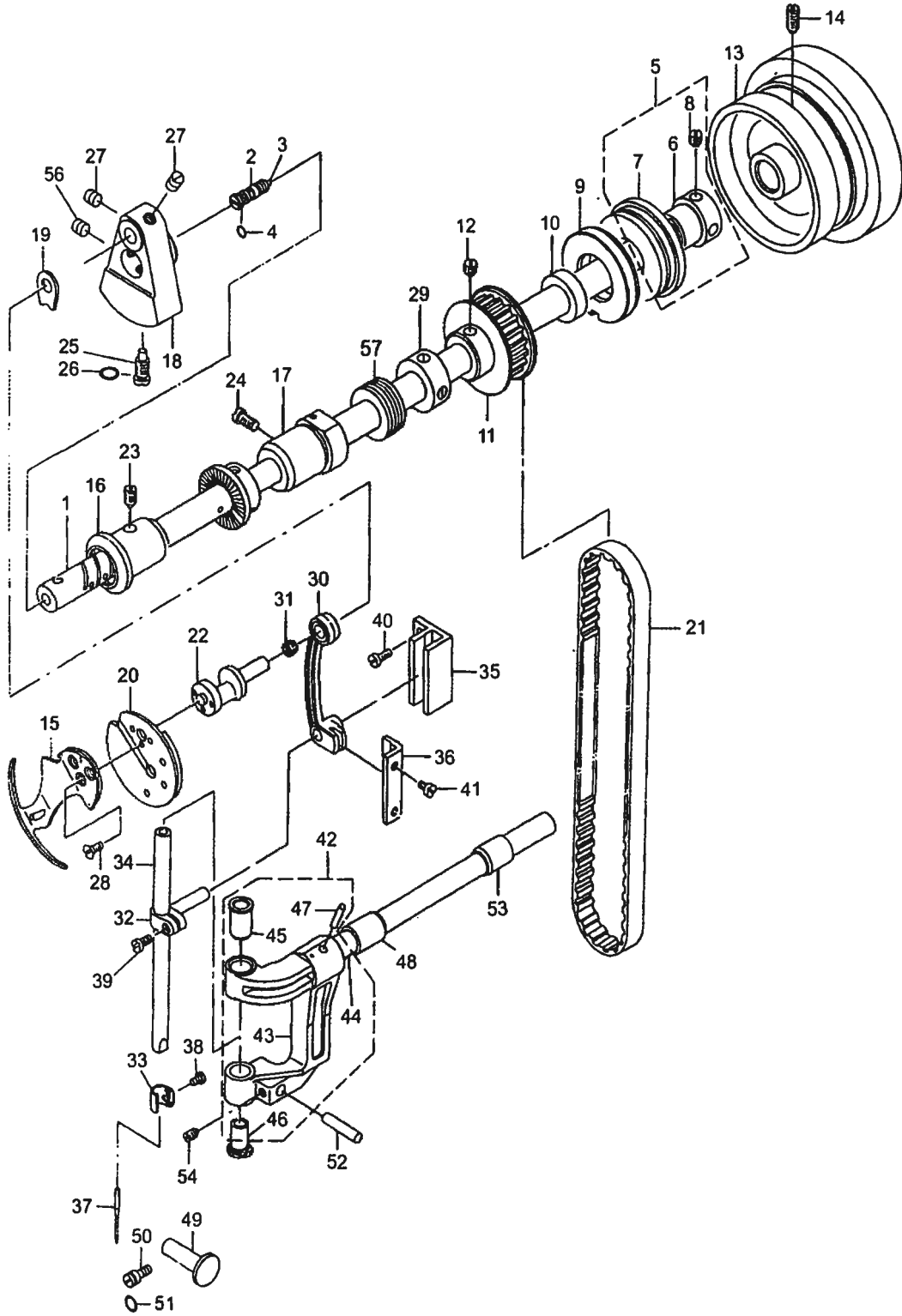

From the library of: Diamond Needle Corp

C.UP SHAFT MECHANISM

Fig. No.	Part No.	Description	Qty.	Remarks
C01	HK305C8001	Up shaft	1	
C02	HK307C8001	Oil adjust pin	1	
C03	HA1111E204	Oil wick	1	
C04	028018	Rubber ring	1	
C05	HK309C7101	Thrust collar assy.	1	
C06	HK310C8001	Pushing	1	
C07	H3205J0662	Bearing	1	6204ZNR
C08	HA307C0662	Screw	2	1/4 (40) × 6
C09	HK312C8001	Oil seal collar	1	
C10	HA306D0066	Oil seal	1	
C11	HK314C8001	Sprocket (up)	1	
C12	HA307C0662	Screw	2	1/4 (40) × 6
C13	HK316C8001	Hand wheel	1	
C14	H2405D0664	Screw	2	15/64 (28) × 14
C15	HK317C8001	Balance	1	
C16	HK318C8001	Up shaft bushing(left)	1	
C17	HK320C8001	Up shaft bushing(middle)	1	
C18	HK322C8001	Counterweight	1	
C19	HK323C8001	Counterweight plate	1	
C20	HK325C7101	Take-up counterweight assy.	1	
C21	HK329C8001	Timing belt	1	
C22	HK330C7101	Needle bar crank	1	
C23	HA100C2020	Screw	1	15/64 (28) × 10
C24	HA100C2020	Screw	1	15/64 (28) × 10
C25	HA100C2070	Screw	1	
C26	HA705C0662	Rubber ring	1	
C27	HA307C0662	Screw	2	
C28	H4100B2180	Screw	3	9/64 (40) × 8.6
C29	HA105D0066	Thrust collar assy.	1	
C30	HK333C7101	Needle bar crank assy.	1	
C31	HA104C0655	Bearing	1	
C32	HK336C8001	Needle bar connection	1	
C33	HK337C8001	Thread rack	1	
C34	HK338C8001	Needle bar	1	
C35	HK339C8001	Needle bar connection guide 1	1	
C36	HK340C8001	Needle bar connection guide 2	1	
C37	HK341C8001	Needle	1	DP × 5 10#
C38	HA100C2170	Screw	1	1/8 (44) × 4.5
C39	H32111D604	Screw	1	9/64 (40) × 8.5
C40	HA300B2160	Screw	2	11/64 (40) × 10
C41	HA300C2030	Screw	2	11/64 (40) × 8
C42	HK343C7101	Needle bar yoke assy.	1	
C43	HK344C8001	Needle bar yoke	1	

C.UP SHAFT MECHANISM

Fig. No.	Part No.	Description	Qty.	Remarks
C44	HK345C8001	Shaft	1	
C45	HK346C8001	Shaft bushing (up)	1	
C46	HK347C8001	Shaft bushing (down)	1	
C47	40200	Spring pin	1	
C48	HK349C8001	Shaft bushing (left)	1	
C49	HK350C8001	Guide pin	1	
C50	HK352C8001	Screw	1	
C51	HC04050019	O-ring	1	
C52	HK354C8001	Needle bar yoke presser	1	
C53	HK355C8001	Shaft bushing (ringht)	1	
C54	HA100B2110	Screw	1	11/64 (40) × 5.5
C56	HK358C8001	Screw	1	9/32 (28) × 6.3
C57	HD409H8001	Bearing	1	

D.NEEDLE VIBRATOR & ADJUSTMENT COMPONENTS(1)

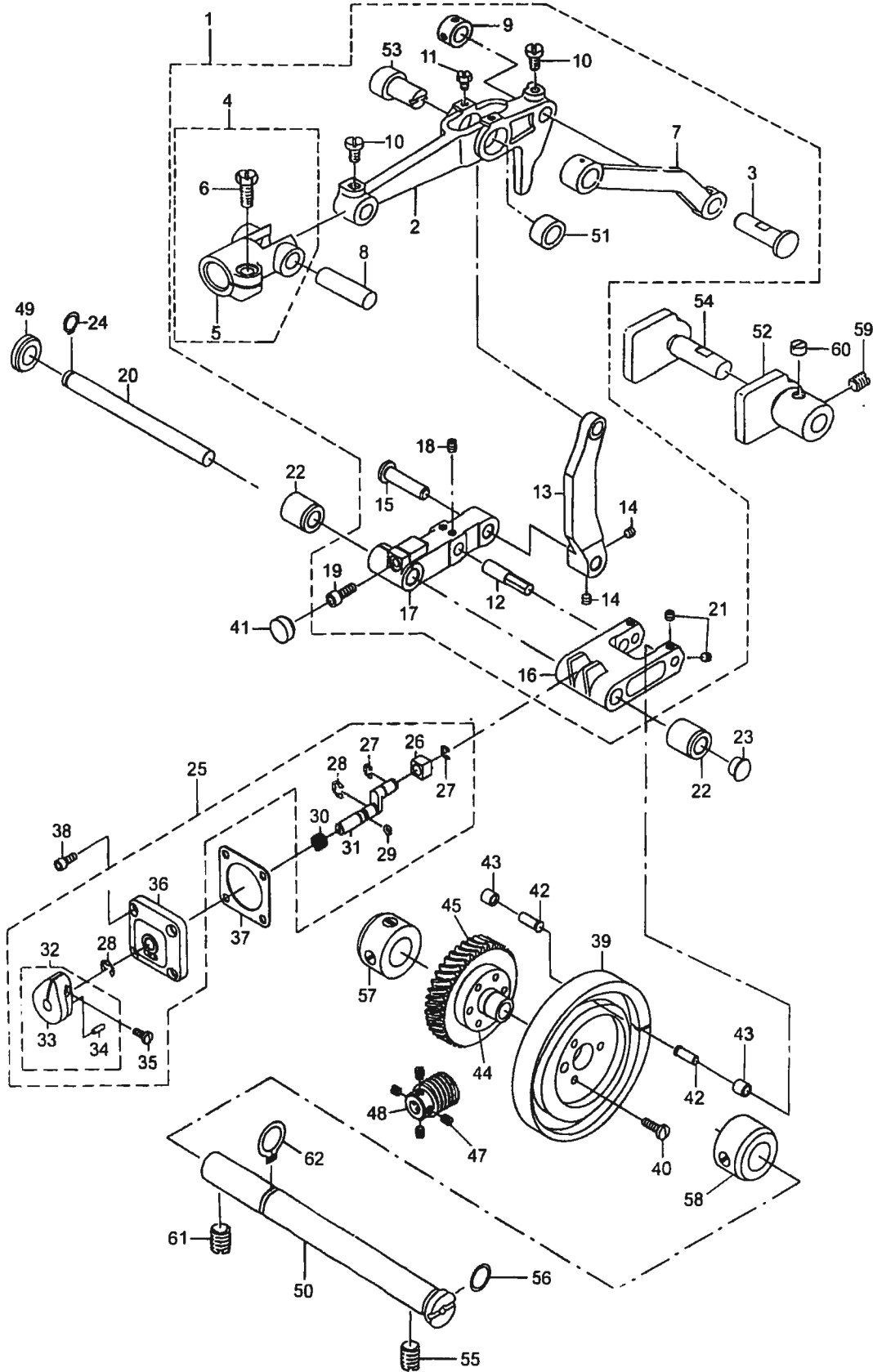

D.NEEDLE VIBRATOR & ADJUSTMENT COMPONENTS(1)

Fig. No.	Part No.	Description	Qty.	Remarks
D01	HK304D7101	Drive link assy.	1	
D02	HK305D8001	Drive link	1	
D03	HK306D8001	Shaft	1	
D04	HK307D7101	Shaft connection assy.	1	
D05	HK308D8001	Shaft connection	1	
D06	HA104G0012	Screw	1	3/16 (28) × 12
D07	HK311D8001	Link	1	
D08	HK312D8001	Pin	1	
D09	HK313D7101	Collar	1	
D10	H3207F0672	Screw	2	11/64 (40) × 8.5
D11	HA7311CC06	Screw	2	9/64 (40) × 6.5
D12	HK317D8001	Pin	1	
D13	HK318D8001	Needle driving rod	1	
D14	H428050040	Screw	2	M5 × 4
D15	HK320D8001	Shaft	1	
D16	HK322D8001	Needle cam arm	1	
D17	HK324D8001	Needle driving arm	1	
D18	H428050060	Screw	2	M5 × 6
D19	H3210F0682	Screw	1	GB/T 70.1 M5 × 14
D20	HK326D8001	Shaft	1	
D21	H428050040	Screw	4	M5 × 4
D22	HK328D8001	Bushing	2	
D23	HA100F2070	Plug	1	
D24	H007009100	C-ring	1	
D25	HK332D7101	Change over basis assy.	1	
D26	HK333D8001	Roller	1	
D27	H007013040	E-ring 4	2	
D28	H007013050	E-ring 5	2	
D29	HC04040019	Rubber ring	1	
D30	HK337D8001	Spring	1	
D31	HK338D8001	Change over slide shaft	1	
D32	HK339D7101	Change over lever assy.	1	
D33	HK340D8001	Change over lever	1	
D34	HK341D8001	Pin	1	
D35	H2404I0034	Screw	1	9/64 (40) × 8.5
D36	HK343D8001	Change over basis	1	
D37	HK344D8001	Gasket	1	
D38	HE929D8001	Screw	4	
D39	HK349D8001	Needle cam	1	
D40	HK319B8001	Screw	3	11/64 (40) × 14
D41	HK33CD8001	Rubber plug	1	
D42	HK352D8001	Needle cam shaft	2	
D43	HK353D8001	Needle cam roller	2	

D.NEEDLE VIBRATOR & ADJUSTMENT COMPONENTS(1)

Fig. No.	Part No.	Description	Qty.	Remarks
D44	HK355D8001	Worm wheel shaft	1	
D45	HK356D8001	Worm wheel	1	
D46	HA100C2190	Screw	3	11/64 (40) × 10
D47	HA307C0662	Screw	4	1/4 (40) × 6
D48	HK359D8001	Worm	1	
D49	HK360D8001	Rubber plug	1	
D50	HK361D8001	Cam shaft	1	
D51	HK362D8001	Bushing	1	
D52	HK364D8001	Drive link guide 1	1	
D53	HK365D8001	Pin	1	
D54	HK366D8001	Drive link guide 2	1	
D55	H4707I8001	Screw	1	1/4 (40) × 6.5
D56	HC04070019	O-ring	1	
D57	HK369D7101	Thrust collar assy.(back)	1	
D58	HK371D7101	Thrust collar assy.(front)	1	
D59	HA3411D308	Screw	1	15/64 (28) × 7
D60	HA105D0662	Screw	1	1/4 (40) × 4
D61	HA108C0663	Screw	1	1/4 (40) × 7
D62	H007009100	Snap spring	1	

E.NEEDLE VIBRATOR & ADJUSTMENT COMPONENTS(2)

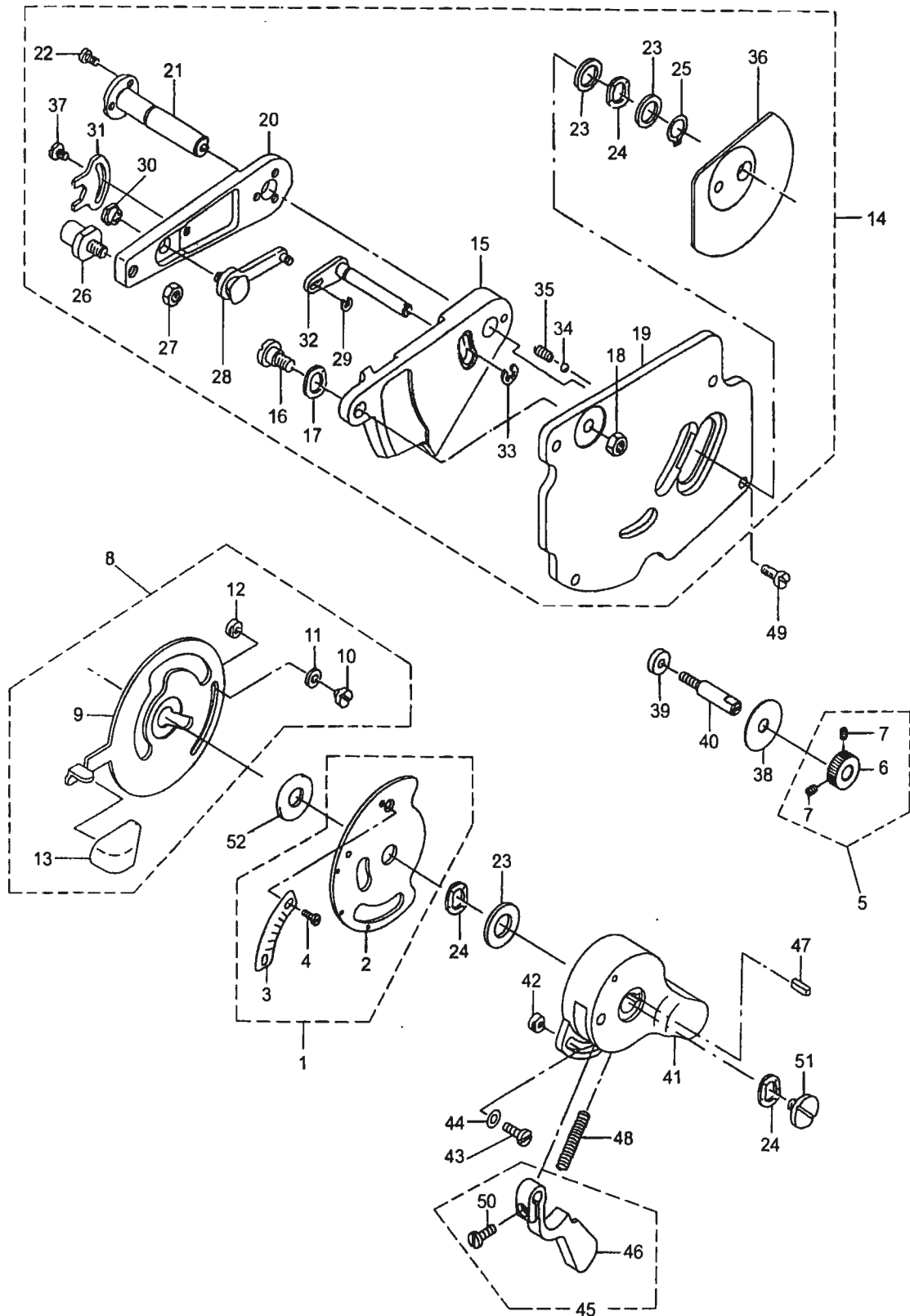

From the library of: Diamond Needle Corp

E.NEEDLE VIBRATOR & ADJUSTMENT COMPONENTS(2)

Fig. No.	Part No.	Description	Qty.	Remarks
E01	HK373D7101	Scale plate assy.	1	
E02	HK374D7101	Scale mounting base assy.	1	
E03	HK377D8001	Scale plate	1	
E04	HK378D8001	Screw	2	1/8 (44) × 2.5
E05	HK385D7101	Adjusting pick-up assy.	1	
E06	HK386D8001	Adjusting pick-up	1	
E07	H427040050	Screw	2	M4 × 5
E08	HK388D7101	Lever assy.	1	
E09	HK389D8001	Lever	1	
E10	HK390D8001	Screw	2	9/64 (40) × 3.5
E11	H3406C8001	Washer	2	3.7 × 7.5 × 0.8
E12	HK391D8001	Nut	2	
E13	HK392D8001	Knob	1	
E14	HK393D7101	Base assy.	1	
E15	HK394D8001	Needle position adjusting base	1	
E16	HK395D8001	High screw	1	
E17	HK396D8001	Waved washer	1	8.5 × 12.5 × 0.3
E18	HA104J6510	Nut	1	15/64 (28)
E19	HK398D8001	Base mounting plate	1	
E20	HK399D8001	Arm	1	
E21	HK30AD8001	Shaft 1	1	
E22	HA104C0659	Screw	3	9/64 (40) × 6
E23	HK30CD8001	Washer	3	10.2 × 18 × 0.5
E24	HK30DD8001	Waved washer	3	10.5 × 14.5 × 0.3
E25	H007009100	Snap ring	1	
E26	HK30FD8001	Shaft 2	1	
E27	HA104J6510	Nut	1	15/64 (28)
E28	HK30HD7101	Stopper assy.	1	
E29	H007013020	E-ring	1	
E30	HK31BD8001	Nut	1	
E31	HK31CD8001	Nut stopper	1	
E32	HK31DD7101	Lever assy.	1	
E33	H007013040	E-ring	1	
E34	HE01040	Hand stop crank shaft ball φ 4	1	
E35	HK31HD8001	Spring	1	
E36	HK31ID8001	Oil shield	1	
E37	HK31JD8001	Screw	1	9/64 (40) × 5
E38	HK32AD8001	Packing	1	
E39	HK32BD8001	Roller	1	
E40	HK32CD8001	Adjusting pick-up screw	1	
E41	HK32ED8001	Knob	1	
E42	HK391D8001	Nut	2	
E43	H32481BC21	Screw	2	9/64 (40) × 6

E.NEEDLE VIBRATOR & ADJUSTMENT COMPONENTS(2)

Fig. No.	Part No.	Description	Qty.	Remarks
E44	H3406C8001	Washer	2	
E45	HK32FD7101	Lever assy.	1	
E46	HK32GD8001	Lever	1	
E47	HK32HD8001	Key	1	
E48	HK32ID8001	Spring	1	
E49	HA300B2160	Screw	4	11/64 (40) × 10
E50	H2404I0034	Screw	1	9/64 (40) × 8.5
E51	HK33BD8001	Screw	1	3/16 (32) × 6.5
E52	H7353G8001	Washer 1	1	10.2 × 18 × 1

F.PRESSER FOOT MECHANISM

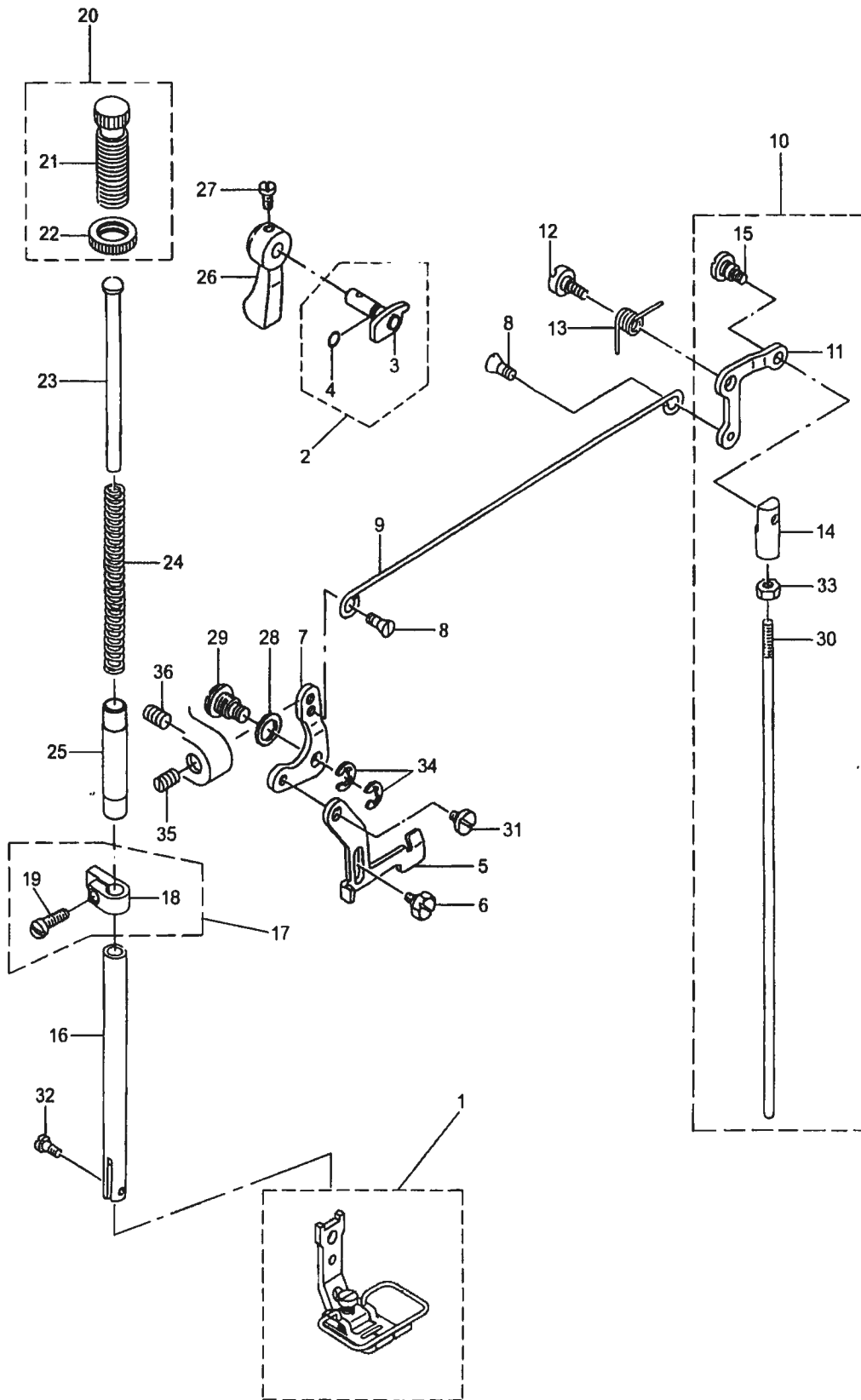

From the library of: Diamond Needle Corp

F.PRESSER FOOT MECHANISM

Fig. No.	Part No.	Description	Qty.	Remarks
F01	HK304E7101	Presser foot assy.	1	
F02	HK312E7101	Hand lifter cam compl.	1	
F03	HK313E8001	Hand lifter cam	1	
F04	HA300H2080	O-ring	1	
F05	HK316E8001	Lifting lever	1	
F06	HK317E8001	Screw	1	
F07	HK318E8001	Lifting lever link (left)	1	
F08	HK319E8001	Screw	2	
F09	HK320E8001	Lifting lever connecting rod	1	
F10	HK321E7101	Lifting lever link (right) assy.	1	
F11	HK322E8001	Lifting lever link (right)	1	
F12	HK323E8001	Screw	1	
F13	HK324E8001	Spring	1	
F14	HK325E8001	Swivel	1	
F15	HA107H0662	Hinge screw	1	
F16	H3200E2010	Presser bar	1	
F17	HK328E7101	Presser bar guide bracket assy.	1	
F18	HK329E8001	Presser bar guide bracket	1	
F19	HA111G0683	Screw	1	11/64 (40) × 12
F20	H5404F7101	Presser spring regulator assy.	1	
F21	H5405F8001	Presser spring regulator	1	
F22	H5406F8001	Nut	1	
F23	HA100H2120	Presser guide bar	1	
F24	HD511Q8001	Spring	1	
F25	HK335E8001	Bushing	1	
F26	HN705F8001	Hand lifter	1	
F27	HA300B2170	Screw	1	11/64 (40) × 10
F28	HK339E8001	Lifting lever gasket	1	
F29	HK340E8001	Hinge screw	1	
F30	HK342E8001	Connecting rod, vertical	1	
F31	HK343E8001	Screw	1	3/16 (32)
F32	H3200E2020	Screw	1	1/8 (44)
F33	H4914I8001	Nut	1	3/16 (28)
F34	H0070130G0	Snap ring	2	
F35	HK346E8001	Screw	1	15/64 (28)
F36	HA305E0662	Screw	1	15/64 (28) × 4.5

G.STITCH LENGTH REGULATOR MECHANISM

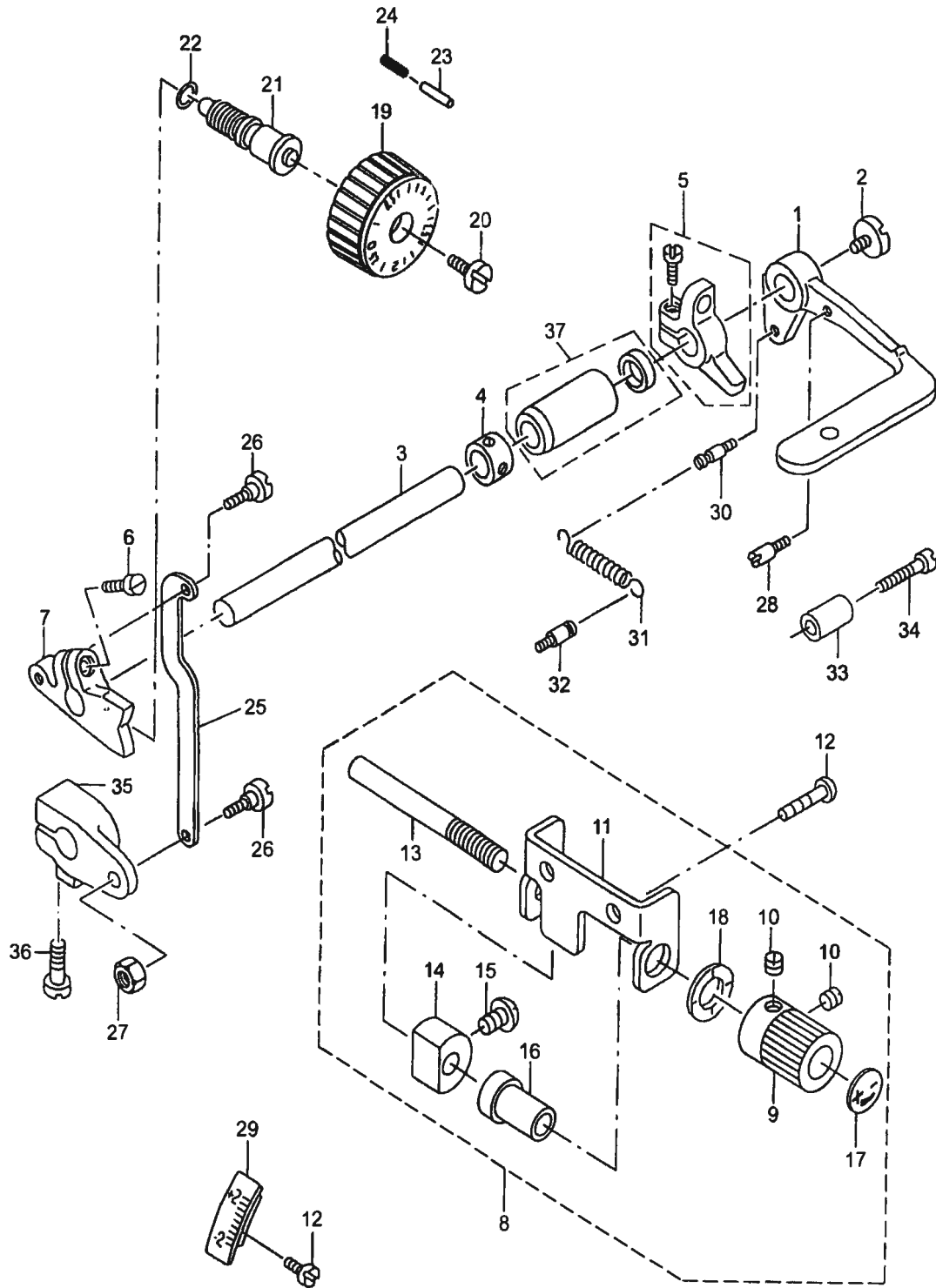

G.STITCH LENGTH REGULATOR MECHANISM

Fig. No.	Part No.	Description	Qty.	Remarks
G01	HK305F8001	Lever	1	
G02	HK33BD8001	Screw	1	3/16(32) × 6.5
G03	HK306F8001	Shaft	1	
G04	HK307F7101	Thrust collar assy.	1	
G05	HK309F7101	Condense stopper arm assy.	1	
G06	HA104G0012	Screw	2	3/16(28) × 12
G07	HK312F8001	Feed driving adjuster	1	
G08	HK313F7101	Knob assy.	1	
G09	HK314F8001	Knob	1	
G10	H6039G8001	Screw	1	11/64(40) × 3.5
G11	HK315F8001	Adjusting screw base	1	
G12	HK331F8001	Screw	4	3/16(28) × 6
G13	HK319F8001	Adjusting screw	1	
G14	HK316F8001	Stopper	1	
G15	HA300C2030	Screw	1	11/64(40) × 8
G16	HK317F8001	Adusting bushing	1	
G17	HK318F8001	Stopper dial plate	1	
G18	HK30DD8001	Waved washer	1	10.5 × 14.5 × 0.3
G19	HK320F8001	Feed dial	1	
G20	HK321F8001	Screw	1	3/16(28) × 18
G21	HK322F8001	Adjusting screw	1	
G22	HA109F0674	O-ring	1	GB1235 14 × 2.4
G23	HA100F2080	Pin	1	
G24	HA100F2090	Spring	1	
G25	HK326F8001	Link	1	
G26	HK327F8001	Screw	2	
G27	H4914I8001	Nut	1	
G28	HK329F8001	Pin	1	
G29	HK330F8001	Scale plate	1	
G30	HK332F8001	Spring suspension 1	1	
G31	HK333F8001	Torsion spring	1	
G32	HK334F8001	Spring suspension 2	1	
G33	HK335F8001	Stipper	1	
G34	HK336F8001	Screw	1	
G35	HK338F8001	Feed variable arm	1	
G36	HA104G0012	Screw	1	3/16(28) × 12
G37	HK340F7101	Bushing assy.	1	

H. FEED MECHANISM COMPONENTS

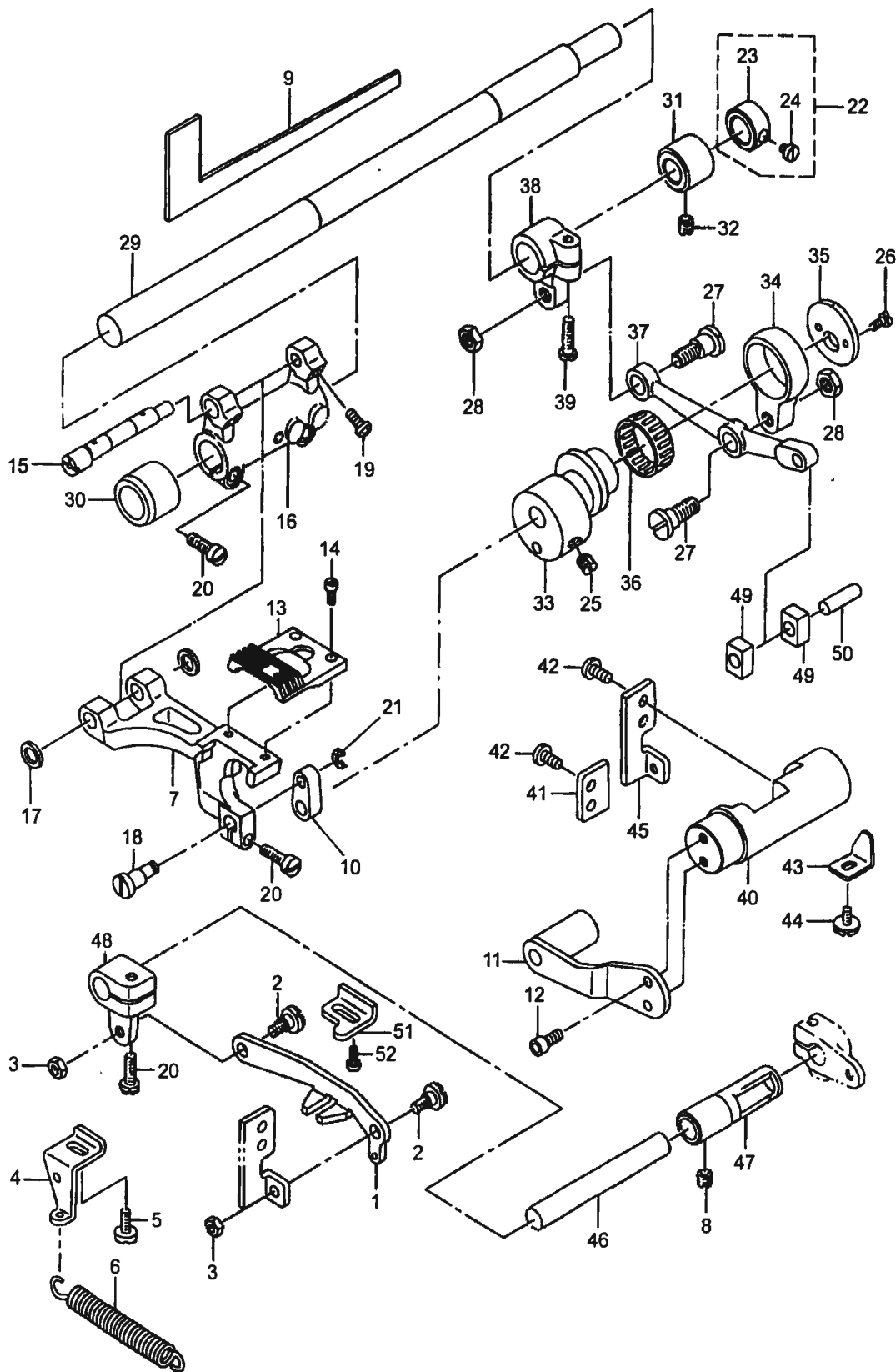

H.FEED MECHANISM COMPONENTS

Fig. No.	Part No.	Description	Qty.	Remarks
H01	HK305G8001	Feed reversal link	1	
H02	HK306G8001	Hinge screw	2	
H03	H4914I8001	Nut	2	3/16 (28)
H04	HK307G8001	Tension spring back	1	
H05	HA100E2150	Screw	1	11/64 (40) × 10
H06	H7209I8001	Spring	1	
H07	HK310G8001	Feed base	1	
H08	HA305E0662	Screw	1	15/64 (28) × 4.5
H09	HK311G8001	Felt	1	
H10	HK312G8001	Link	1	
H11	HK313G7101	Balance weight compl.	1	
H12	HE929D8001	Screw	2	11/64 (40) × 7.5
H13	HK316G8001	Feed dog	1	
H14	H32211G205	Screw	2	1/8 (40) × 6.3
H15	HK317G8001	Shaft	1	
H16	HK318G8001	Feed rocker	1	
H17	HK319G8001	Spacer	2	
H18	HK320G8001	Link shaft	1	
H19	HK321G8001	Screw	2	3/16 (28) × 9
H20	HA104G0012	Screw	4	3/16 (28) × 14
H21	H007013035	E-ring	1	3.5
H22	HK322G7101	Collar assy.	1	
H23	HK323G8001	Collar	1	
H24	HA307C0662	Screw	2	1/4 (40) × 7
H25	HA108C0663	Screw	2	1/4 (40) × 8
H26	HE106F8001	Screw	2	1/8 (44) × 6.4
H27	HK324G8001	Screw	2	
H28	H2010J0066	Nut	2	9/32 (28)
H29	HK325G8001	Shaft	1	
H30	HK326G8001	Bushing (left)	1	
H31	HK327G8001	Bushing (right)	1	
H32	HA3411D308	Screw	1	15/64 (28) × 7
H33	HK330G8001	Eccentric cam	1	
H34	HK331G8001	Rod	1	
H35	HK332G8001	Side disc plate	1	
H36	HK333G8001	Bearing	1	K22 × 26 × 10 (NTN)
H37	HK334G8001	Connecting rod	1	
H38	HK336G8001	Feed rocker shaft crank	1	
H39	HA304G0656	Screw	1	3/16 (28) × 15.
H40	HK338G8001	Feed driving rocker	1	
H41	HK339G8001	Plate (left)	1	
H42	HA700F2100	Screw	4	11/64 (40) × 8.5
H43	HK340G8001	Stopper plate	1	

H.FEED MECHANISM COMPONENTS

Fig. No.	Part No.	Description	Qty.	Remarks
H44	H2400I2080	Screw	1	11/64 (40) × 7
H45	HK342G8001	Plate (right)	1	
H46	HK343G8001	Shaft	1	
H47	HK344G8001	Bushing	1	
H48	HK346G8001	Feed variable arm	1	
H49	HK347G8001	Feed driving rocker block	2	
H50	HK348G8001	Pin	1	
H51	HK349G8001	Reverse feed limiter	1	
H52	HA100E2150	Screw	1	11/64 (40) × 11

I. LOWER SHAFT MECHANISM

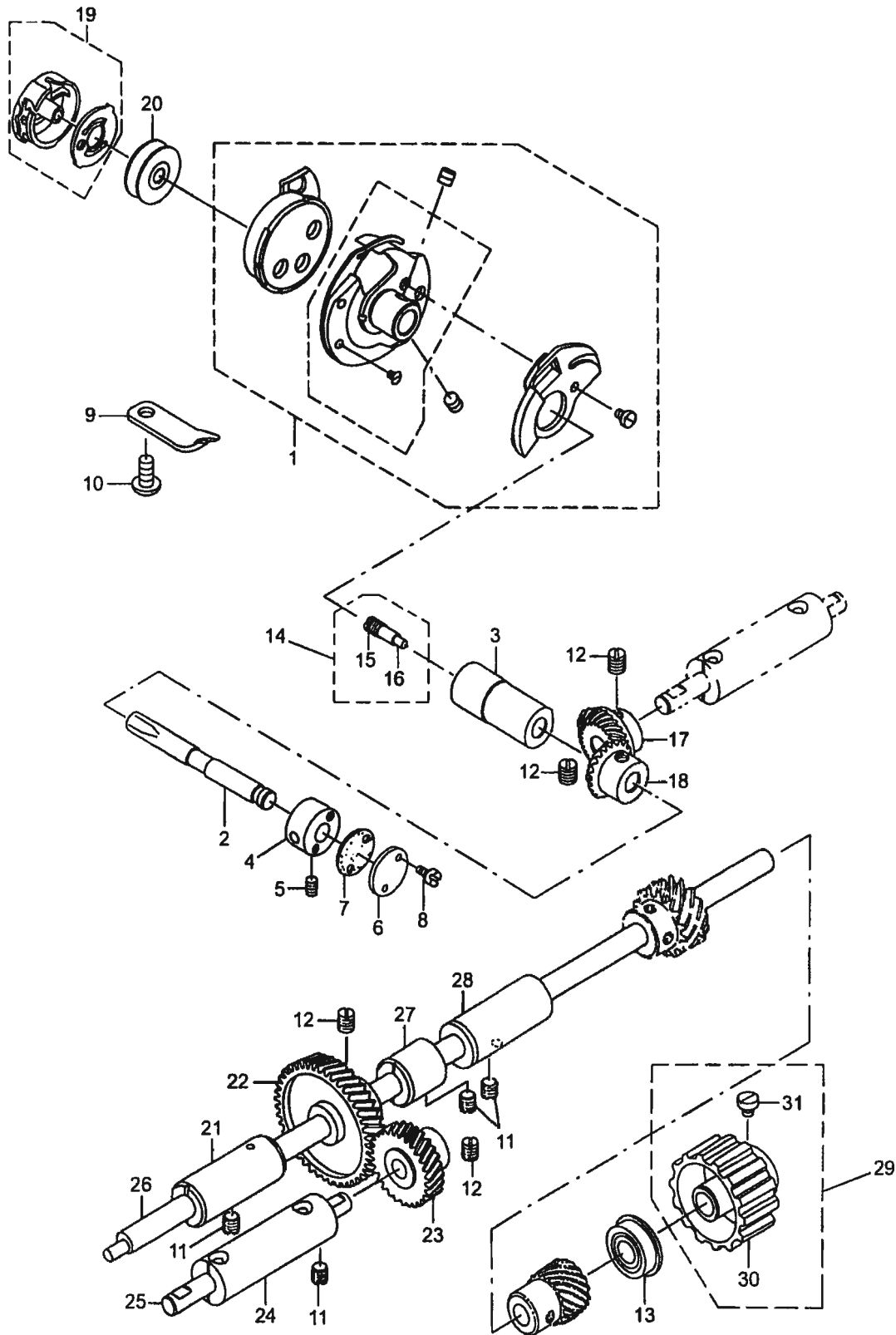

From the library of: Diamond Needle Corp

I.LOWER SHAFT MECHANISM

Fig. No.	Part No.	Description	Qty.	Remarks
I01	HK304H7101	Hook compl.	1	DP2-57 (3LP2R)
I02	HK308H8001	Hook shaft	1	
I03	HK309H8001	Hook shaft bushing	1	
I04	HK310H8001	Hook shaft bushing	1	
I05	HA3411D308	Screw	1	15/64 (28) × 7
I06	HK312H8001	Bushing cap	1	
I07	HK313H8001	Gasket	1	
I08	HE106F8001	Screw	2	1/8 (44) × 6
I09	HK314H8001	Inner hook stopper	1	
I10	HA300C2030	Screw	1	11/64 (40) × 9
I11	HA3411D308	Screw	4	15/64 (28) × 7
I12	HA108C0663	Screw	8	1/4 (40) × 8
I13	HK315H8001	Bearing	1	9. 525 × 22. 225
I14	HA104E0011	Oil seal screw assy.	1	
I15	HA1111E104	Oil seal screw	1	
I16	HA1111E204	Oil wick	1	
I17	HK319H8001	Gear	1	
I18	HK320H8001	Gear	1	
I19	HK321H8001	Bobbin case assy.	1	225-24169
I20	HK322H8001	Bobbin	1	225-96704
I21	HK324H8001	Bushing	1	
I22	HK325H8001	Helical gear	1	
I23	HK326H8001	Helical gear	1	
I24	HK327H8001	Bushing	1	
I25	HK328H8001	Shaft	1	
I26	HK329H7101	Hook driving shaft	1	
I27	HK331H8001	Bushing	1	
I28	HK333H8001	Bushing	1	
I29	HK334H7101	Sprocket assy.	1	
I30	HK335H8001	Sprocket	1	
I31	HA307C0662	Screw	2	1/4 (40) × 7

J.OIL LUBRICATION MECHANISM

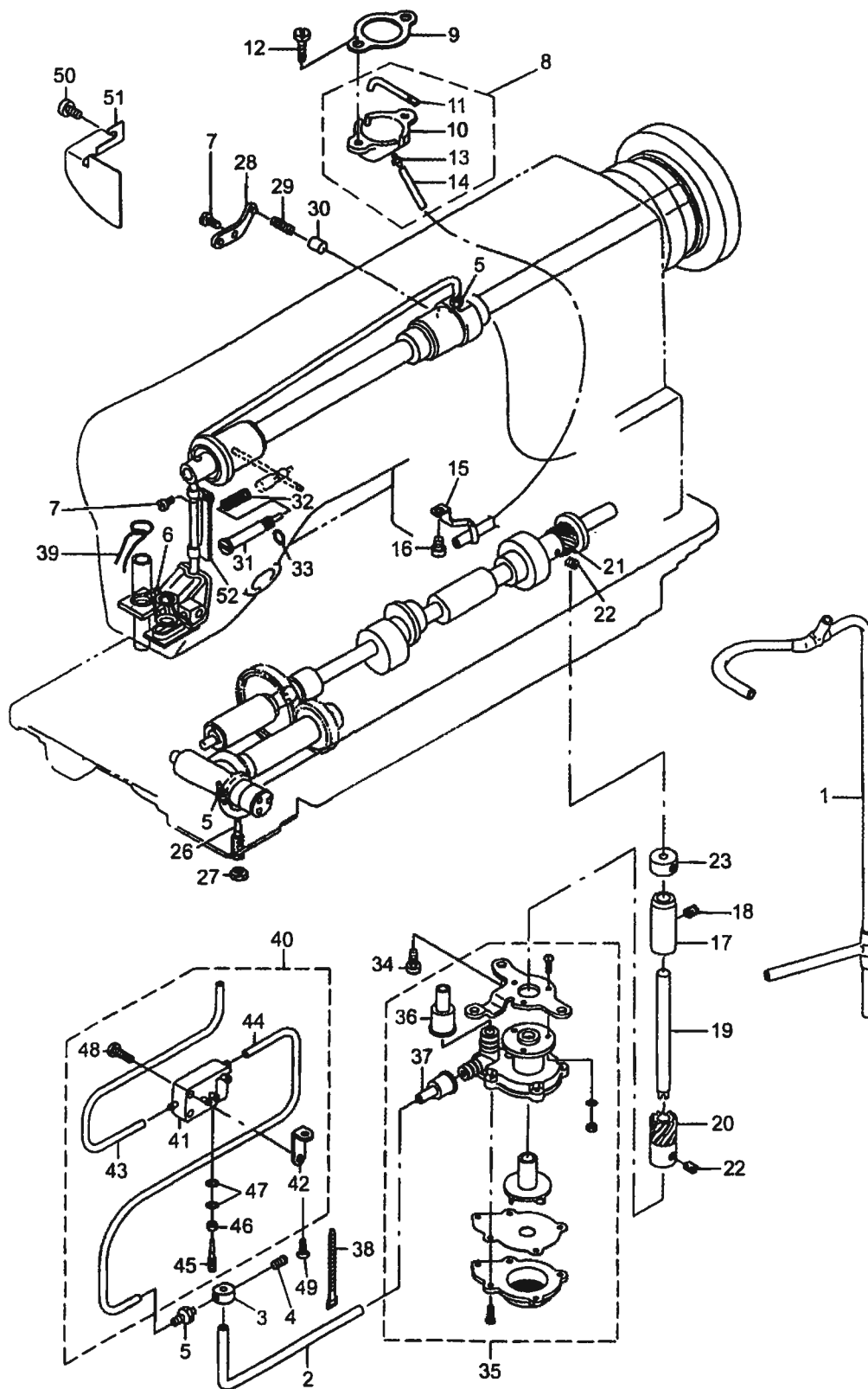

From the library of: Diamond Needle Corp

J.OIL LUBRICATION MECHANISM

Fig. No.	Part No.	Description	Qty.	Remarks
J01	HK304I7101	Oil supplypipe assy.	1	
J02	HK309I8001	Oil supplypipe	1	
J03	HK310I8001	Distributor	1	
J04	H3000D2030	Screw	1	11/64 (40) × 4.5
J05	HK311I8001	Connecting screw	3	
J06	HK313I8001	Felt presser	1	
J07	HA300C2030	Screw	2	11/64 (40) × 8
J08	HK314I7101	Oil tank assy.	1	
J09	HK315I8001	Gasket	1	
J10	HK316I8001	Oil tank	1	
J11	HK317I8001	Oil tube	1	
J12	HK319B8001	Screw	2	11/64 (40) × 14
J13	HK380B8001	Connecting screw	1	
J14	HK319I8001	Oil tube	1	
J15	HK320I8001	Oil felt guide	1	
J16	H200000360	Screw	1	11/64 (40) × 7
J17	HK321I8001	Bushing	1	
J18	HA3411D308	Screw	1	15/64 (28) × 7
J19	HK322I8001	Shaft	1	
J20	HK323I8001	Pump driving gear	1	
J21	HK324I8001	Pump driving gear	1	
J22	HA105D0662	Screw	4	1/4 (40) × 4
J23	HK325I7101	Thrust collar assy.	1	
J24	HK326I8001	Thrust collar	1	
J26	HK329I8001	Screw	1	
J27	HA104J6510	Nut	1	
J28	HK330I8001	Plunger thrust plate	1	
J29	HK331I8001	Spring	1	
J30	HK332I8001	Plunger	1	
J31	HK334I8001	Screw	1	
J32	HK335I8001	Spring	1	
J33	HC04060019	O-ring	1	
J34	HA100E2150	Screw	2	
J35	HK340I7101	Lubricating oil pump assy.	1	
J36	HK342I8001	Rubber joint	1	
J37	HK343I8001	Rubber joint	1	
J38	HA700M0070	Cable band	1	
J39	HK353I8001	Oil wick	1	
J40	HK354I7101	Oil regulating valve assy.	1	
J41	HK355I8001	Oil regulating valve	1	
J42	HK356I8001	Wiper link joint	1	
J43	HK319I8002	Oil tube	1	
J44	HK319I8003	Oil tube	1	

J.OIL LUBRICATION MECHANISM

Fig. No.	Part No.	Description	Qty.	Remarks
J45	HK359I8001	Oil adjusting screw	1	
J46	H5729F8001	Nut	1	11/64 (40)
J47	H3406C8001	Washer	2	
J48	HK319B8001	Screw	1	11/64 (40) × 14
J49	HA300C2030	Screw	1	11/64 (40) × 8
J50	H5733F8001	Screw	1	11/64 (40) × 8
J51	HK364I8001	Oil shield	1	
J52	HK365I7101	Felt assy.	1	

K.ACCESSORIES

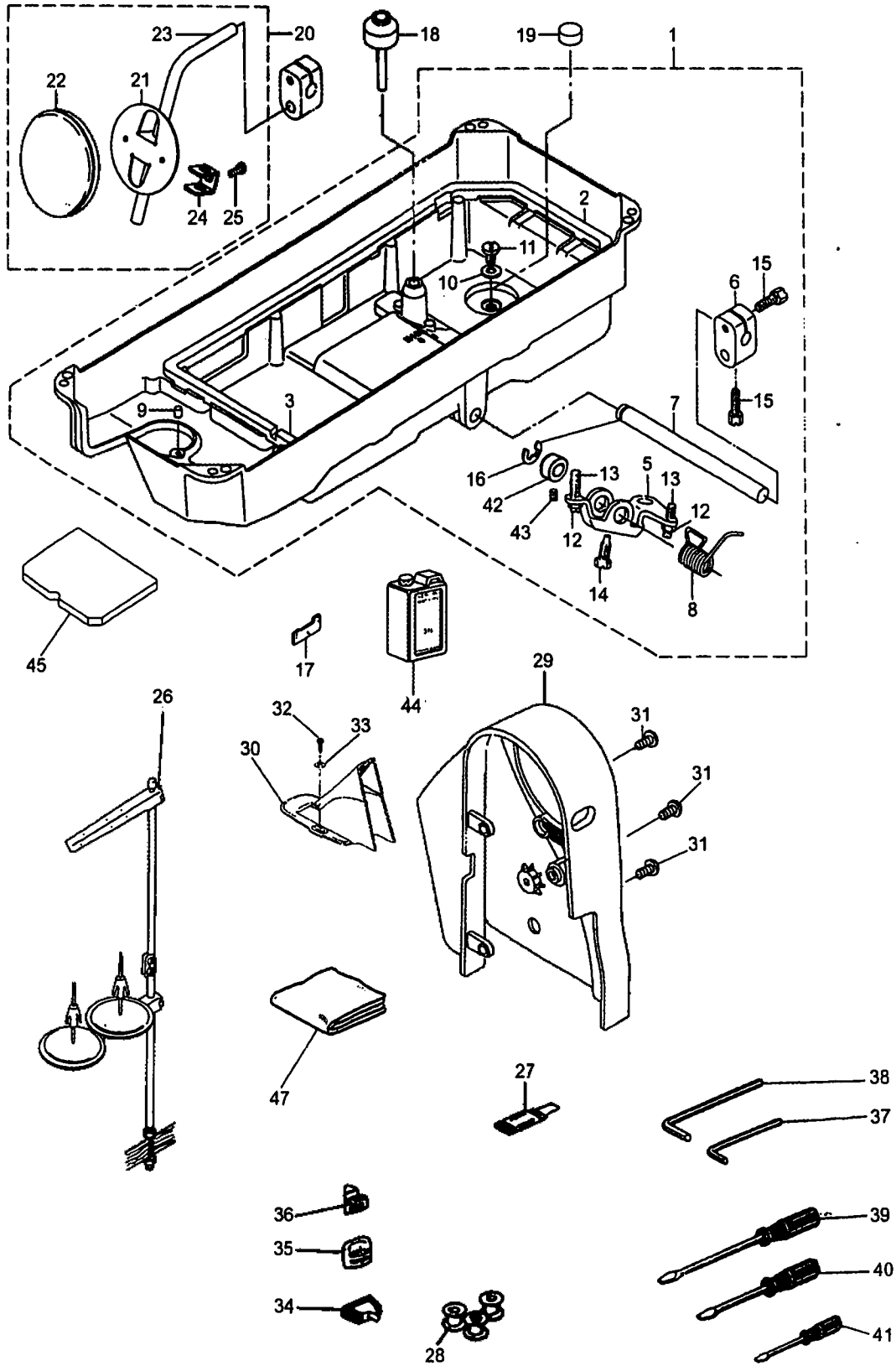

From the library of: Diamond Needle Corp

K.ACCESSORIES

Fig. No.	Part No.	Description	Qty.	Remarks
K01	HK304J7101	Oil reservoir assy.	1	
K02	HA104J0655	Oil reservoir gasket	1	730
K03	HK306J8001	Oil reservoir gasket	1	210
K05	HA104J0658	Connecting rot.	1	
K06	HA106J0663	Bracket	1	
K07	HA300J2160	Knee press rod	1	
K08	HK308J8001	Spring	1	
K09	HK309J8001	Rubber pluge	1	
K10	HA104J0653	Rubber ring	1	
K11	HA104J0652	Screw	1	5/16 " (28) × 10
K12	HA104J6510	Nut	2	
K13	HA104J0659	Screw	2	
K14	HA110D0672	Screw	1	
K15	HA300J2180	Screw	2	
K16	H007013090	E-ring	1	
K17	HK310J8001	Timming gaug	1	
K18	HA106J0661	Knee press lifter rod	1	
K19	HA100J2120	Magnet	1	
K20	HA106J0066	Knee press plate assy.	1	
K21	HA106J0665	Knee press plate	1	
K22	HA106J0668	Knee press plate cover	1	
K23	HA106J0662	Knee ligter plate rod	1	
K24	HA106J0666	Knee press plate holder	1	
K25	HA106J0667	Screw	1	
K26	HA200J2030	Thread stand assy.	1	
K27	HK341C8001	Needle	4	DP × 5 10#
K28	HK322H8001	Bobbin	3	
K29	HK314J8001	Belt cover	1	
K30	HA313J7101	Belt cover assy.	1	
K31	HA300B2160	Screw	3	11/64 (40) × 10
K32	H806045250	Wood screw	2	4.5 × 25
K33	50	Washer	2	φ 5
K34	HA110J0070	Hinge with rubber cushion	2	
K35	HA100J2090	Head cushion(large)	2	
K36	HA100J2100	Head cushion(small)	2	
K37	HB01020	Hexagon socket screw key 2mm	1	
K38	HB01030	Hexagon socket screw key 3mm	1	
K39	HA300J2070	Screw driver (L)	1	
K40	HA300J2200	Screw driver (M)	1	
K41	HA300J2210	Screw driver (S)	1	
K42	HD506S8001	Collar	1	
K43	HA305E0662	Screw	2	15/64 (28) × 4.5
K44	HA300J2170	Oil tank	1	

K.ACCESSORIES

Fig. No.	Part No.	Description	Qty.	Remarks
K45	HK317J8001	Oil reservoir base	1	
K47	HA100J2180	Head cover	1	