

Purchasing Dept
Copy

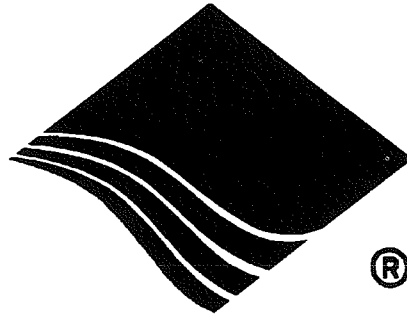

HIGHLEAD

GC2698-1/GC2698-1B

CYLINDER-BED UNISON FEED SEWING MACHINE

Instruction Manual
Parts Catalog

SHANGHAI HUIGONG NO.3 SEWING MACHINE FACTORY



The Machine Conforms to the Following European Regulations:

EN60204-31: 1996、 98/37/EC、 DIN5310、 DIN5318、 73/23/EEC (93/68/EEC)

CONTENTS

INSTRUCTION MANUAL

1、 SAFETY	1
1) GENERAL SAFETY TIPS	1
2) IMPORTANT POINTS FOR THE EMPLOYER.....	1
3) SERVICE AND TECHNICAL PERSONNEL	1
4) DANGER TIPS	2
2、 TESTING, TRANSPORT & STORAGE	3
1) TIPS ON TESTING	3
2) TRANSPORT WITHIN THE CUSTOMER SITE	3
3) STORAGE.....	3
3、 INSTALLATION & FIRST OPERATION	3
1) ASSEMBLING THE BOBBIN STANDS	3
2) FIRST OPERATION.....	3
4、 SPECIFICATIONS	3
5、 PREPARATION.....	4
1) ATTACHING THE NEEDLE.....	4
2) WINDING THE LOWER THREAD, REGULATING THE TENSION OF THE THREAD	4
3) TAKING OUT THE BOBBIN CAPSULE	5
4) ROUTING THE UPPER THREAD	6
5) REGULATING THE TENSION OF THE THREAD.....	6
6、 STITCH LENGTH ADJUSTING LEVER / REVERSE SEWING.....	7
7、 MAINTENANCE & CARE.....	7
1) MAINTENANCE AND CARE INTERVALS.....	7
2) CLEANING.....	7
3) GENERAL OILING	8
4) OILING THE HEAD	8
5) OILING THE ROTATING HOOK.....	8
8、 ADJUSTMENT	8
1) TIPS FOR ADJUSTMENT.....	8

2) ABBREVIATIONS.....	9
3) POSITION OF THE FEED DOG.....	9
4) NEEDLE HEIGHT (PRE-ADJUSTMENT).....	10
5) NEEDLE IN THE MIDDLE OF THE STITCHING HOLE	10
6) PRESSER FOOT, WALKING FOOT AND FEED DOG SLIDING MOVEMENT.....	11
7) HOOK POSITIONER, GRAB DISTANCE AND NEEDLE HEIGHT.....	11
8) HYDRAULIC MOVEMENT OF THE WALKING FOOT AND PRESSER FOOT	12
9) PRESSER FOOT	12
10) UPPER THREAD TENSION REGULATION.....	13
11) THREAD TAKE-UP SPRING.....	13
12) BOBBIN WINDER.....	13
13) ADJUSTMENT OF PRESSER PRESSURE.....	14

CATALOG

A、 ARM BED AND ITS ACCESSORIES (1)	15
A、 ARM BED AND ITS ACCESSORIES (2)	16
B、 FEEDING AND FEED LIFTING & LOWER SHAFT MECHANISM.....	19
C、 ARM SHAFT MECHANISM.....	22
D、 STITCH REGULATOR MECHANISM.....	24
E、 PRESSER FOOT MECHANISM.....	26
F、 NEEDLE BAR FEEDING MECHANISM (1)	28
F、 NEEDLE BAR FEEDING MECHANISM (2)	29
G、 ACCESSORIES	32

1. SAFETY

1) GENERAL SAFETY TIPS

① The machine should only be used after studying the accompanying instruction manual and only by specially instructed operating staff.

② Before bringing the machine into service read the safety tips and the instruction manual of the engine manufacturer.

③ The machine may only be used according to their regulations and not without the accompanying protective fittings. All relevant safety regulations should also be observed.

④ When changing sewing tools (for example needle, presser foot, needle plate and bobbin winder), when threading up, when leaving the work place as well as during maintenance work the machine should be unplugged or switched off at the main switch.

⑤ Daily maintenance work should only be carried out by specially trained personnel.

⑥ Repair work as well as special maintenance work should only be carried out by skilled workers or specially trained personnel.

⑦ Working on the electrical equipment should only be carried out by qualified electricians.

⑧ Working on active parts and equipment are not permitted.

⑨ Only the spare parts provided by us should be used during repairs. We explicitly point out that the spare parts and accessories that are not supplied by us are also not tested or passed by us. The installation or use of such products can in certain circumstances reduce the predetermined quality of your machine. We take no responsibility for damage caused by the use of non-original parts.

2) IMPORTANT POINTS FOR THE EMPLOYER

① This instruction manual is a component of the machine and must always be at the disposal of the machine operators. It is necessary to read the manual before using the machine for the first time.

② Operation and maintenance personnel must be instructed on safety features of the machine and safe working methods.

③ The employer must ensure that the machine is only used if it is in perfect condition.

④ The employer should make sure that only authorised persons are permitted to work on the machine.

⑤ Further information can be obtained from the responsible sales office.

3) SERVICE AND TECHNICAL PERSONNEL

(1) Service Personnel

Service personnel are responsible for the preparing, running and cleaning of the machine as well as the elimination of faults in the sewing. Service personnel must observe the following points:

① to follow the safety guidelines in the instruction manual

② to avoid any type of work which may reduce the safety of the machine

- ③ to wear tight-fitting clothes and avoid wearing jewellery, like necklaces and rings
- ④ to report immediately changes in the machine which may reduce safety to the employer.

(2) Technical Personnel

Technical personnel are responsible for the lubrication, maintenance, repair and adjustments to the machine.

Technical personnel must observe the following points:

- ① To follow safety guidelines in the instruction manual
- ② Before beginning maintenance work the main switch must be switched off and it must be ensured that it will not be switched on again.
- ③ Working on active parts and equipment is not permitted.
- ④ After repair and maintenance work the protective covering must be put back and the electric control box must be closed.

4) DANGER TIPS (Fig.1)

① During operation a space of 1m in front of and behind the machine should be maintained so that unrestricted access is possible.

② During sewing do not reach into the needle area! Be careful of the danger of injury from the needle.

③ During operation do not leave objects lying on the table or in the needle plate tongue. Objects can get jammed or knocked away. Danger of injury will result.

④ With mechanically operated clutch motors without operation barriers, operators should wait for the motor to stop. Danger of injury will result.

⑤ Do not use the machine without the thread take-up cover 1! Danger of injury from the movement of the threaded will result.

⑥ Do not use the machine without the finger guard 2! Danger of injury from the outward and upward movement of the needle will result.

⑦ Do not use the machine without the lifting arm cap 3!
Danger of injury from the rotating arm will result.

⑧ Do not use the machine without the belt cover 4! Danger of injury from the rotating belt will result.

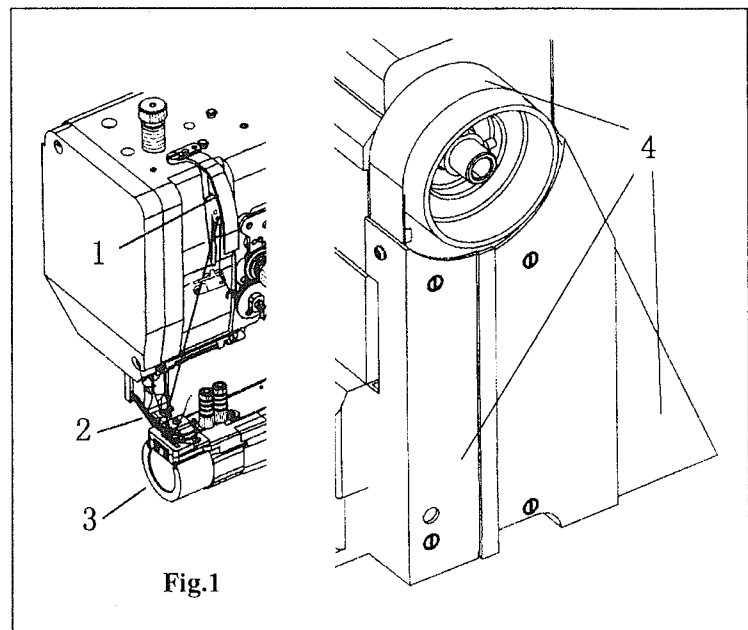

2. TESTING, TRANSPORT & STORAGE

1) TIPS ON TESTING

The machine was tested before delivery according to the EN60204-3-1 edition1/86.

2) TRANSPORT WITHIN THE CUSTOMER SITE

Transport within the customer site is not the responsibility of the manufacturer. It should be ensured that the machine is correctly transported.

3) STORAGE

The machine can be stored unused for up to 6 months. It should be protected against dirt and moisture. If the machine is to be stored longer the individual parts, in particular the sliding plates, should be protected against corrosion, with an oil film for example.

3. INSTALLATION & FIRST OPERATION

The machine should only be installed and started by qualified technical personnel. All the relevant safety regulations should be observed. Suitable electricity supply must be available at the installation site (see technical data). It must be ensured that there is an even and solid ground surface as well as sufficient lighting at the installation site.

1) ASSEMBLING THE BOBBIN STANDS

Place the bobbin stands in the drill hole in the table plate and fix them into place with the enclosed nuts.

2) FIRST OPERATION

Before the first operation check the electric cables in case of any possible damage.

- ① Clean and oil the machine thoroughly
- ② Allow technical specialists to check whether the machine's motor may be connected to the available main supply and whether it is properly plugged in. If there is any deviation, do not start the machine.
- ③ When the machine is running the balance wheel should be turned towards the operator. Otherwise let technical specialists adjust the motor.

4. SPECIFICATIONS

Max. Sewing Speed	2200rpm			
Max. Stitch Length	6mm			
Thread Take-up Lever Stroke	59.55mm			
Needle Bar Stroke	33.4mm			
Presser Foot Stroke	By Hand	8mm	By Knee	13mm
Alternating Movement				
Needle	DP×35LR 14#-16#			
Rotating Hook	HSH-BTR			
Lubrication System	Manual			
Electric Machinery	1400 rpm 370W			

5. Preparation

① All regulations and guidelines in this manual should be observed, with special attention being paid to safety regulations.

② All preparation work may only be carried out by specially instructed personnel. Before all preparation work the machine should be disconnected from the main electricity supply by switching off the main switch or unplugging it.

1) ATTACHING THE NEEDLE (Fig.2)

The choice of the right needle depends on the model of the machine as well as the thread and material to be used.

- ① Switch off the machine!
- ② Loosen needle-holding screw
- ③ Put the needle in as far as it will go (the long needle groove should point to the left)
- ④ Tighten needle-holding screw 1

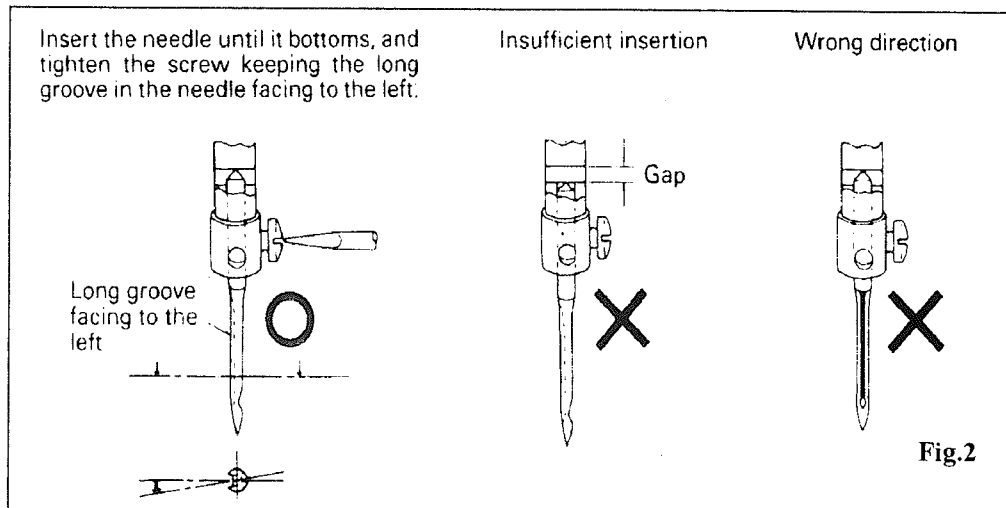

2) WINDING THE LOWER THREAD, REGULATING THE TENSION OF THE THREAD (Fig.3)

- ① Put an empty bobbin onto the bobbin shaft and thread the thread according to Fig 3
- ② Push the bobbin catch in the direction of the arrow
- ③ The bobbin is filled during the progress of the sewing.
- ④ The bobbinet stops automatically when the bobbin is full.
- ⑤ The tension of the thread on the bobbin can be adjusted with knurl-screw 2.

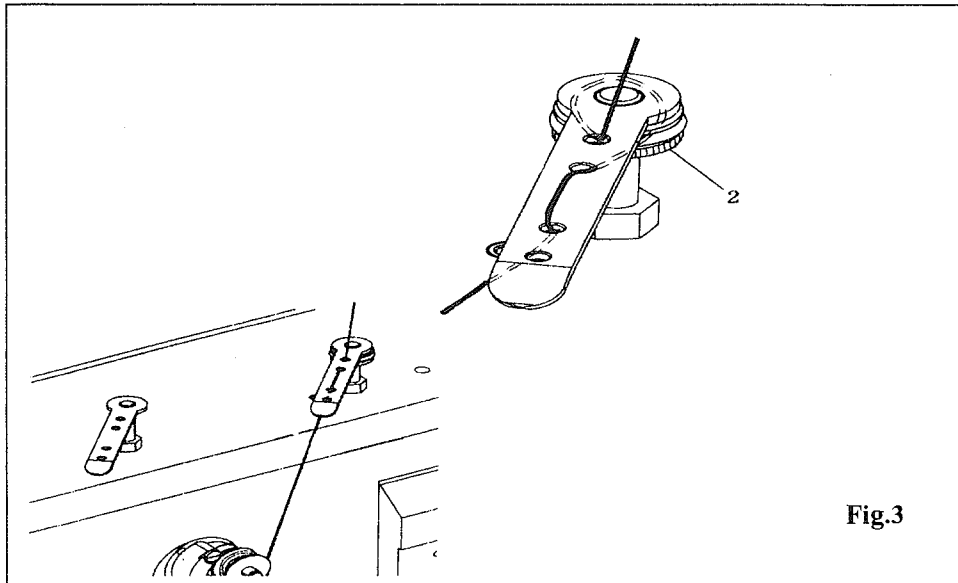

Fig.3

3) TAKING OUT THE BOBBIN CAPSULE (Fig.4)

Switch off the machine.

(1) Take the bobbin capsule out

- ① Lift up handle and take out bobbin capsule. Thread the bobbin capsule.
- ② Thread the bobbin according to Fig 4
- ③ The bobbin should point in the direction of the arrow when taking up the thread.

(2) Putting the bobbin capsule into place

Switch off the machine.

- ① Pulling out 5cm thread tail from the bobbin
- ② Hold the bobbin so that the bobbin thread is would in right direction and put it into the hook

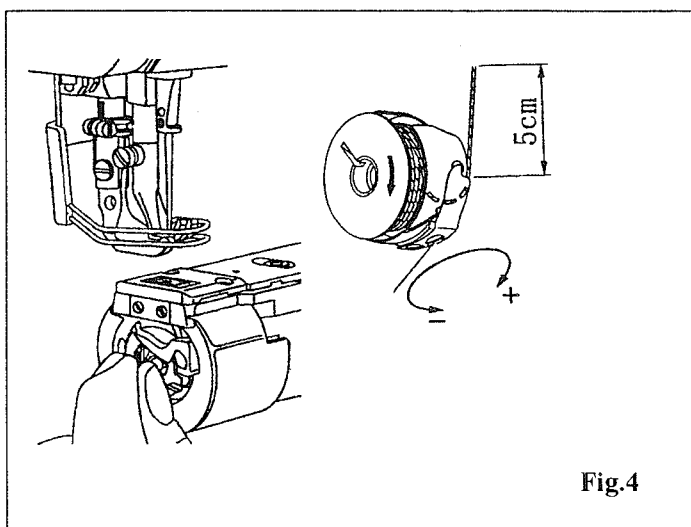
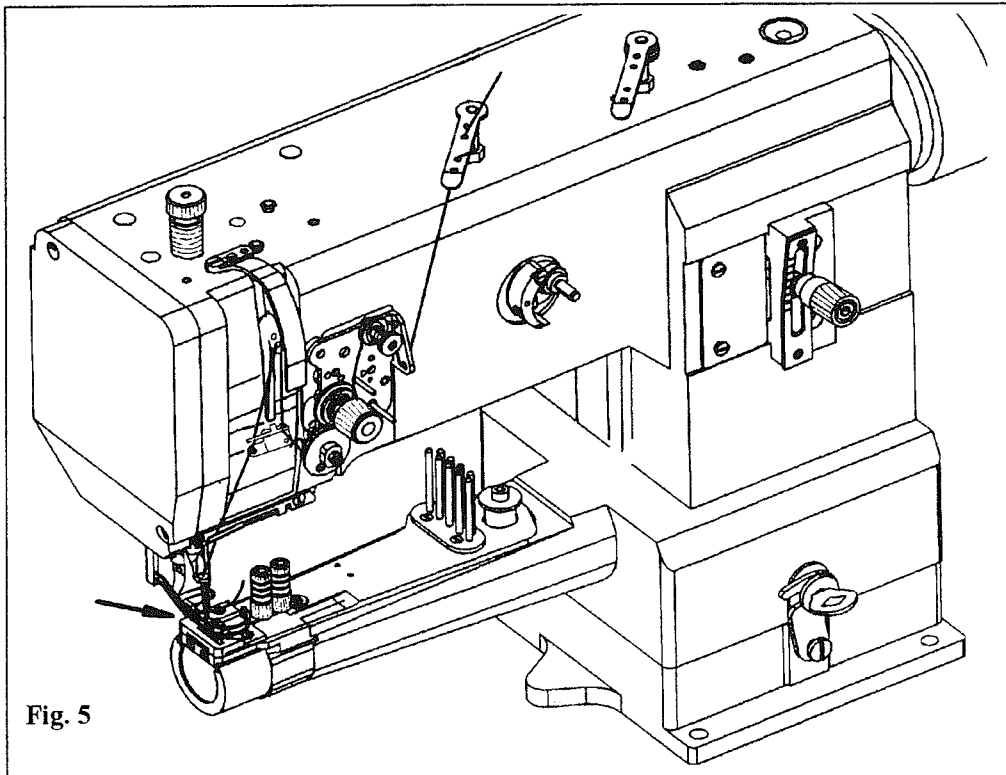

Fig.4

4) ROUTING THE UPPER THREAD (Fig.5)

Switch off the machine.

Route the machine according to fig 5. The needle should be routed from the left (see arrow).



5) REGULATING THE TENSION OF THE THREAD (Fig.6)

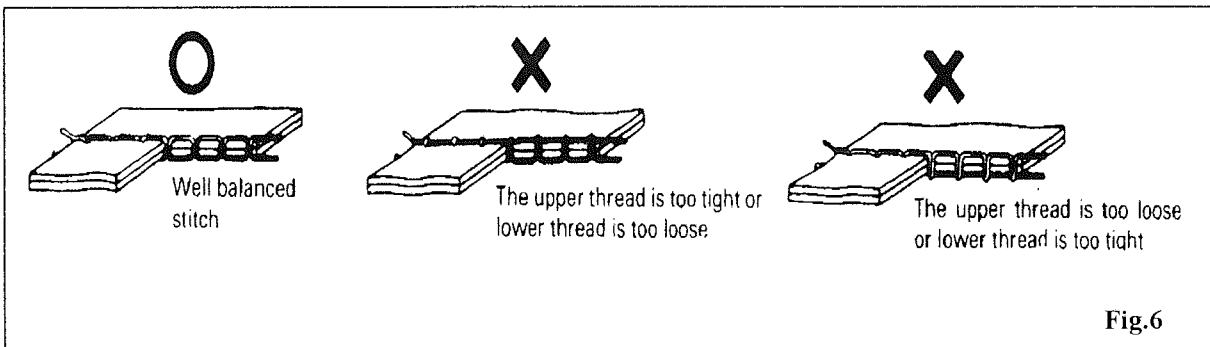

(1) Upper thread tension (Fig. 7)

Regulate the tension 1 so that the stitches tie together in the sewing mate

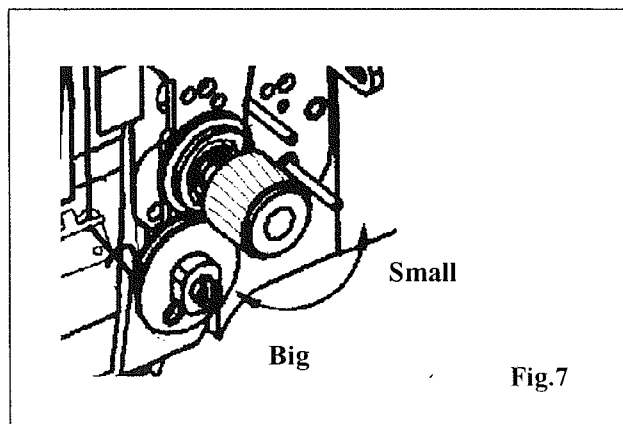

(2) Lower thread tension (Fig. 8)

Lower thread tension can be adjusted by rotating screw "A".

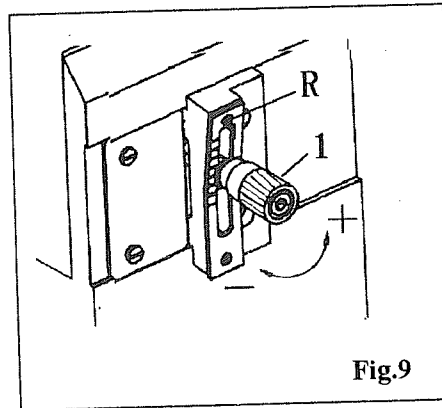
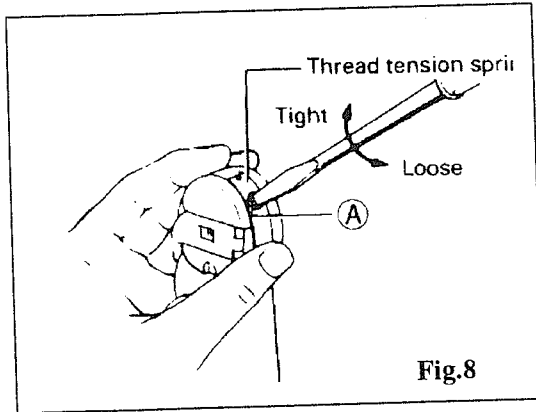

6. STITCH LENGTH ADJUSTING LEVER / REVERSE SEWING (Fig.9)

1) Adjust length of stitches by turning the knurl nut 1

2) Reverse Sewing

Push the knurl nut 1 up as far as it will go (position R)

7. MAINTENANCE & CARE

1) MAINTENANCE AND CARE INTERVALS

- ① Cleaning - daily, more often with constant use.
- ② General oiling - twice weekly.
- ③ Oiling of the head - twice weekly.
- ④ Oiling of the rotating hook - daily.

2) CLEANING

Switch off the machine!

- ① Clean the rotating hook and rotating hook area daily, more often with constant use.
- ② Bring the needle bar to its highest position and remove the free arm cap.
- ③ Take out the bobbin capsule and bobbin.
- ④ Unscrew capsule holder piece.
- ⑤ Take out screw and lift up the rotating hook handle.
- ⑥ Turn the balance wheel until point stands at the same height as rotating hook point .
- ⑦ Take out the lower capsule and clean the rotating hook path with petroleum.
- ⑧ Put it back together in reverse order of the above. Make sure that the nose on the back of the capsule

holder piece meshes with groove.

- ⑨ Unscrew rotating hook handle and put in the bobbin capsule with bobbin.
- ⑩ Draw back the free arm cap.

3) GENERAL OILING (Fig.10, Fig.11)

Use white spindle oil.

Oil all the bearing positions shown in Fig 10 and 11 twice weekly.

Danger of being crushed between the top part and the base!

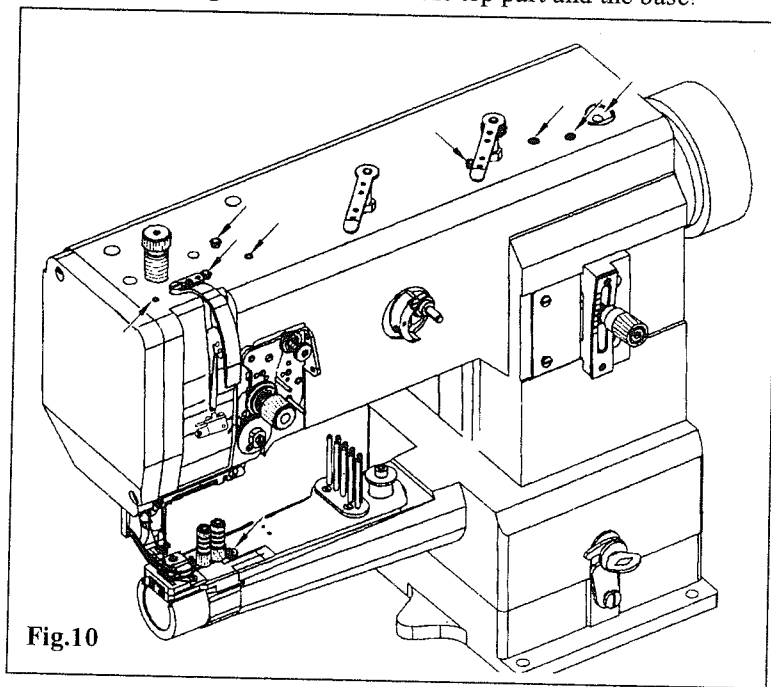

Fig.10

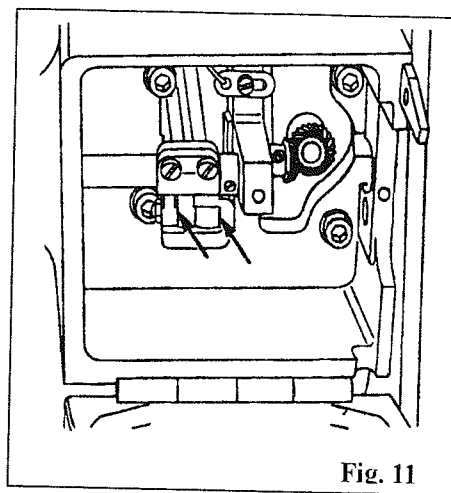

Fig. 11

4) OILING THE HEAD (Fig.12)

Switch off the machine!

① Take off the cover and oil all the bearing and sliding positions shown in fig 12 twice weekly.

② Then screw the cover back on.

Use white spindle oil.

5) OILING THE ROTATING HOOK (Fig.13)

Switch off the machine!

① Take the bobbin capsule out and drip one or two drops of oil into the rotating hook path (fig 13) once daily.

② Then put the bobbin capsule back in.

8. ADJUSTMENT

1) TIPS FOR ADJUSTMENT

① All adjustments in this manual apply to a completely assembled machine. Covers, which have to be unscrewed and screwed on again for adjustment work are not mentioned in the text.

② The screws or nuts mentioned in brackets are to be loosened before adjustments and tightened again afterwards.

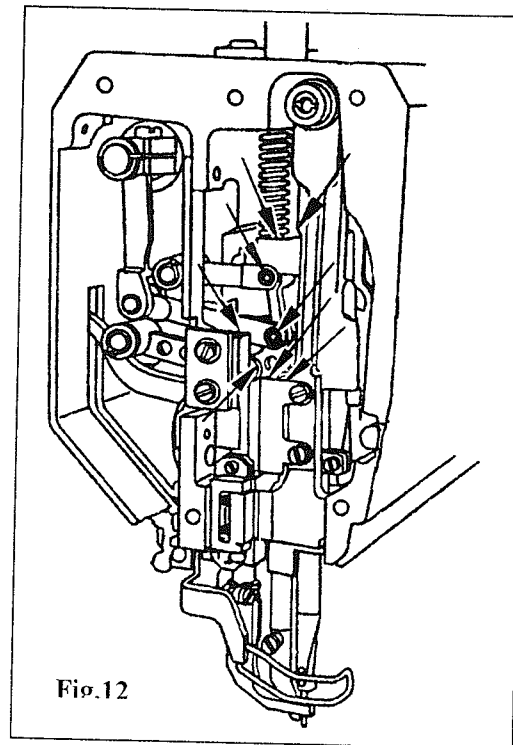

Fig.12

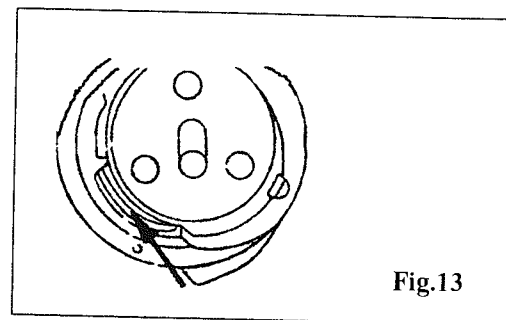

Fig.13

2) ABBREVIATIONS

UD – Upper deadlock

LD – Lower deadlock

3) POSITION OF THE FEED DOG

(1) Positioning the feed dog at an angle to the direction of sewing (Fig.14)

The feed dog 1 should be the same distance right and left from the needle plate.

Move the feed dog 1 (screws 2) according to the above rule.

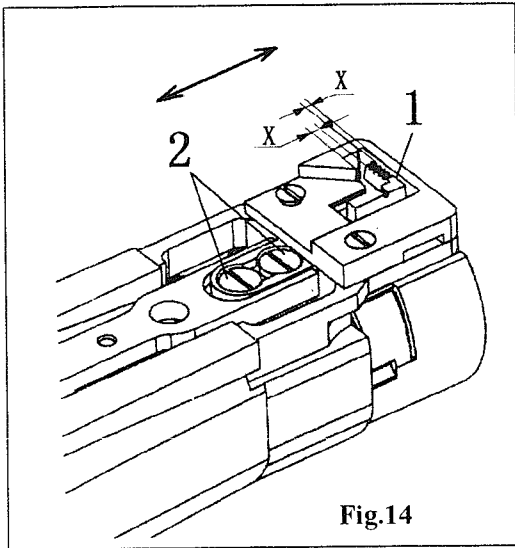

Fig.14

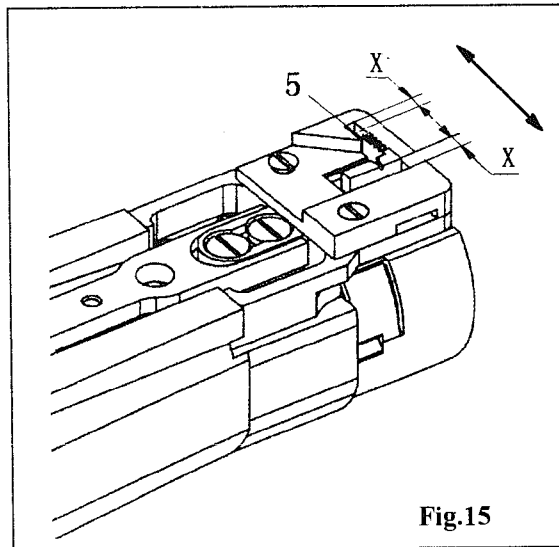

Fig.15

(2) Positioning the feed dog in the direction of sewing (Fig.15 Fig16)

The feed dog 5 should keep the same distance in front and behind the needle plate when moving backwards and forwards when adjusting the maximum stitch-length.

- ① Adjust the maximum stitch-length.
- ② Push the crank 1 (screws 2) as far as possible to the left on the crank-area 3. The left screw must still be on the crank-area.
- ③ Loosen screws 4
- ④ Move the feed dog 5 according to the rule.
- ⑤ Tighten screws 4.

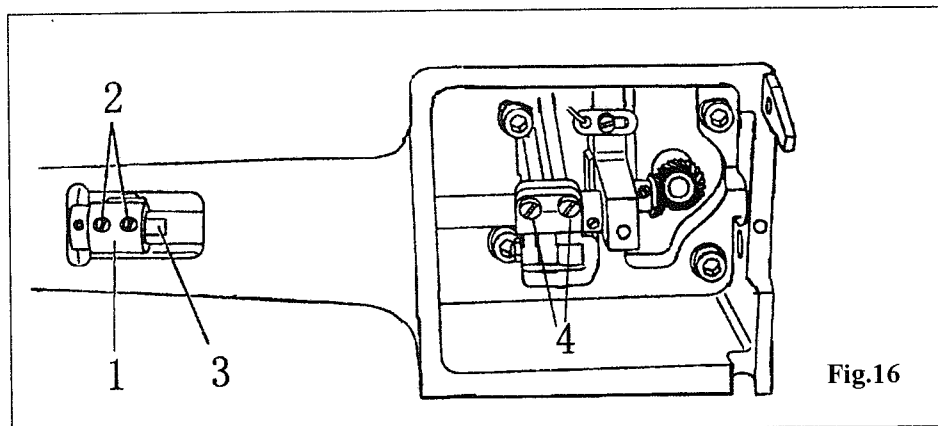

Fig.16

4) NEEDLE HEIGHT (PRE-ADJUSTMENT)

(Fig.17)

When the needle bar is in lower position the distance between the needle bar and the needle plate should be 15mm.

Move needle bar 1 (screw 2) according to the rule above without turning it to the side.

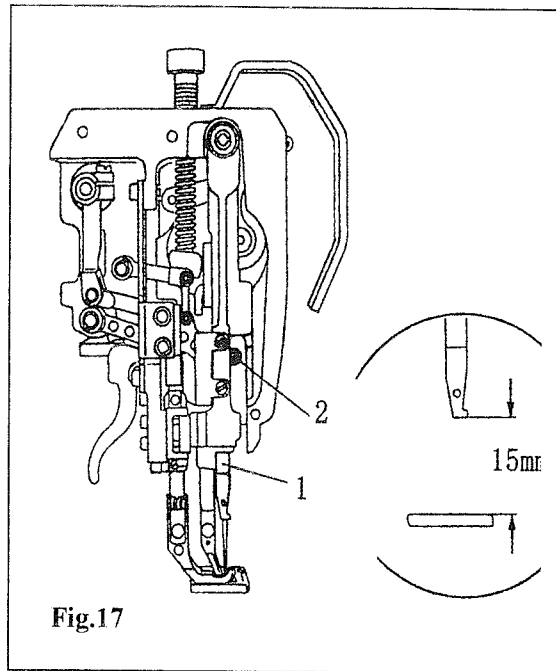

Fig.17

5) NEEDLE IN THE MIDDLE OF THE STITCHING WHOLE (Fig.18)

With the length of the stitch at '0' the needle should pierce exactly in the middle of the needle plate hole.

- ① Unscrew the presser foot 1 and the walking foot 2.
- ② Adjust the stitch-length to '0' and bring the needle bar to upper position.
- ③ Insert a new needle, loosen screws 3, 4, 5 & 6.
- ④ Bring the needle immediately over the feed dog by turning the balance wheel.
- ⑤ Move the needle bar 7 according to the rule.
- ⑥ Tighten screws 3, 4 & 5.
- ⑦ Bring stop 8 up to the needle bar area 7 and tighten screw 6.

Note: The needle bar 7 in guide 9 and the needle rock frame should move easily.

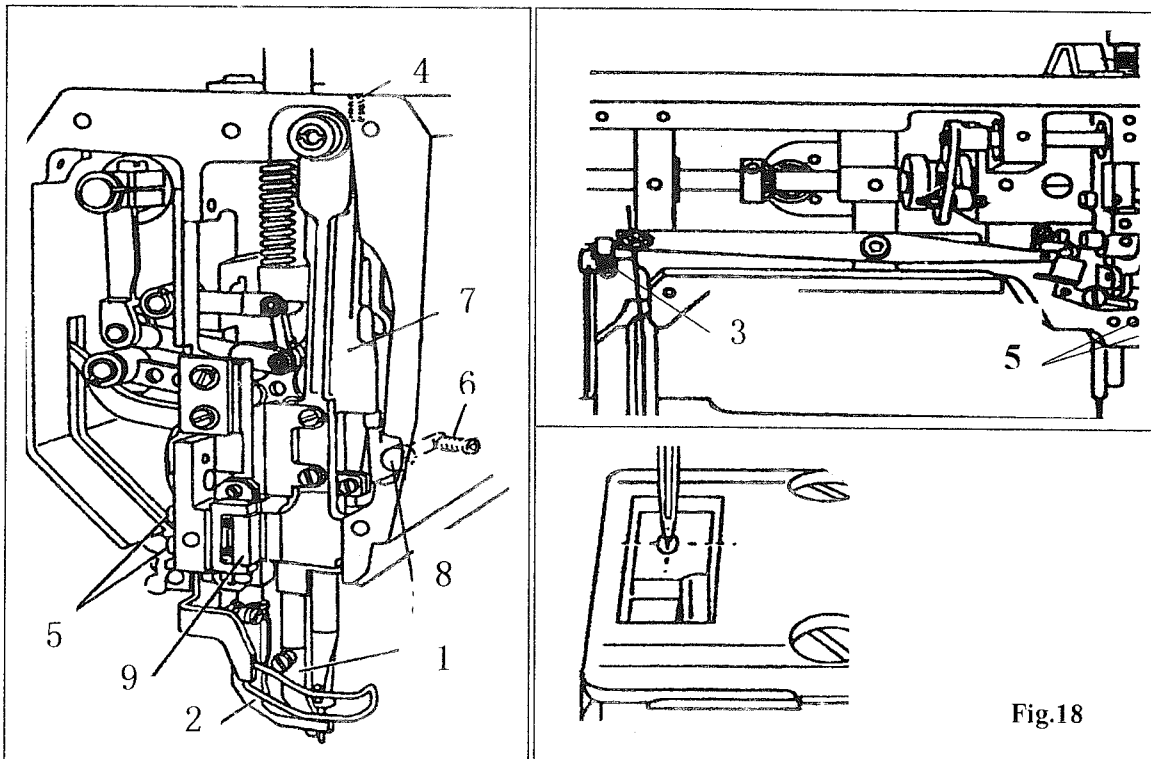

Fig.18

6) PRESSER FOOT, WALKING FOOT AND FEED DOG SLIDING MOVEMENT

(Fig.19)

When adjusting the maximum stitch-length and when the needle bar is in lower position, walking foot, presser foot and feed dog should make no movement when operating the lever.

- ① Adjust the maximum stitch length
- ② Loosen screw 1 only enough so that the feed lifting cam 2 turns round the shaft.
- ③ Bring the needle into lower position
- ④ While retaining this position, first push the eccentricity of the feed lifting cam 2 upwards, observing the above rule when operating the lever.
- ⑤ Tighten screws 1.

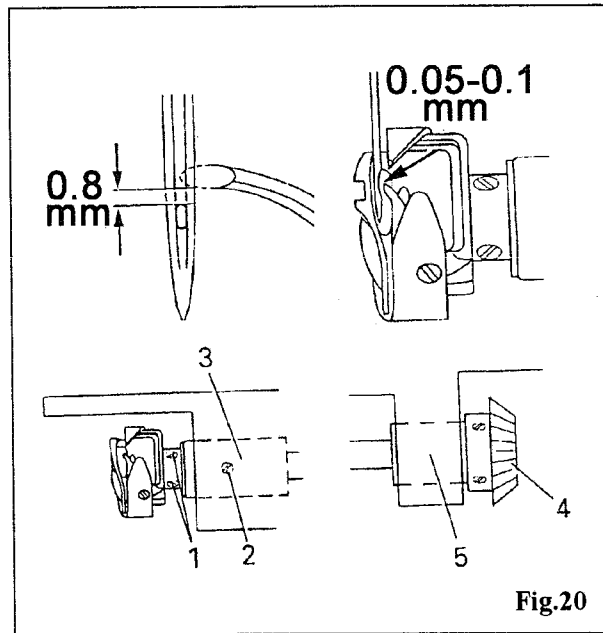
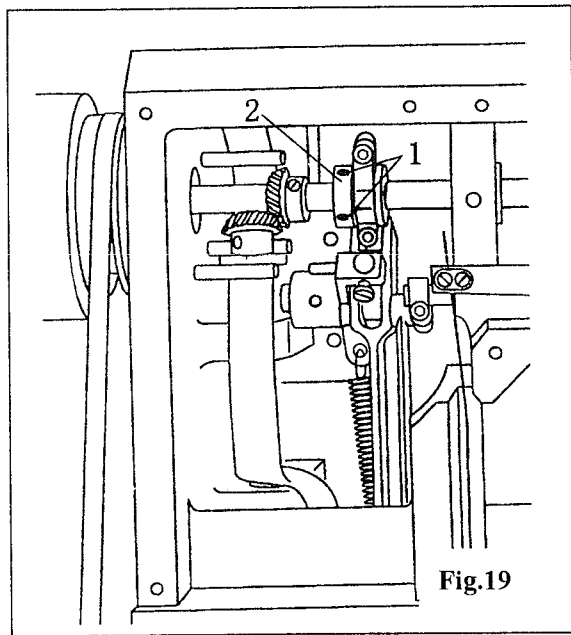

7) HOOK POSITIONED, GRAB DISTANCE AND NEEDLE HEIGHT (Fig. 20)

When the stitch length is '0' and the position of the hook positioned is 1.8mm below the LD needle bar then;

- ① The grab point should stand at 'mid-needle' and the distance to the needle should be 0.05 – 0.1mm.
- ② The top edge of the eye of the needle should be 0.8mm below the grab point.
 - I) Adjust the stitch length to '0' and loosen screws 1 & 2 (screw 2 is on the back of the machine)
 - II) Bring the needle to lower position and push the 1.8mm thick measuring plate well under the lower needle bar bearing, bring the screw clip down to the measuring plate and screw tight.
 - III) Remove the measuring plate and turn the balance wheel until the screw clip lies at the needle bar.
 - IV) Push the grab onto the grab shaft according to rule ①
 - V) Turn the grab according to rule ② (adjust the needle height afterwards if necessary)
 - VI) Bring the grab shaft bearing 3 towards the grab and tighten screw 2.
 - VII) Tighten screw 1 making sure that the bevel wheel 4 is level with bearing 5.

8) HYDRAULIC MOVEMENT OF THE WALKING FOOT AND PRESSER FOOT

(Fig.21)

When the walking foot 3 is sitting on the needle plate the presser foot 6 and the needlepoint should reach the needle plate at the same time in the presser foot hub.

- ① Loosen nut 1.
- ② Push up bolts 2 and tighten nut 1.
- ③ Let the walking foot 3 rest on the needle plate.
- ④ Loosen screws 4 far enough that the lifting eccentric 5 turns around.
- ⑤ Turn lifting eccentric 5 according to the rule
- ⑥ Tighten screws 4
- ⑦ Do a test run.

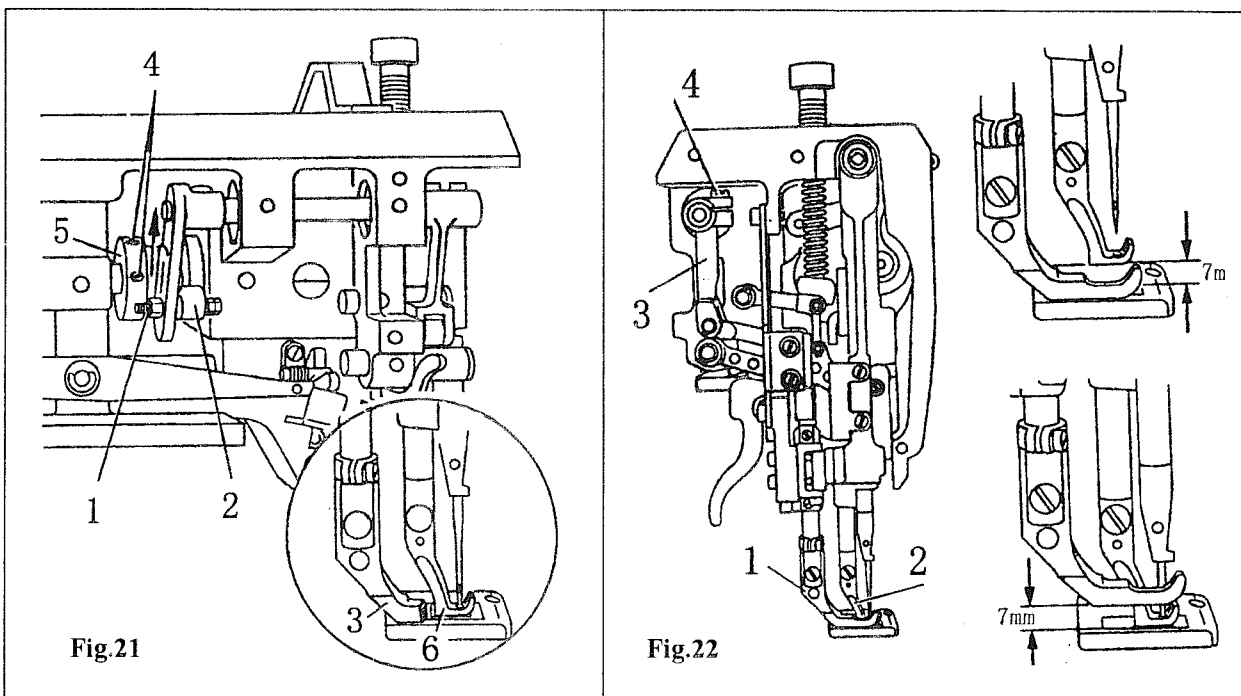

9) PRESSER FOOT (Fig.22)

With the maximum presser foot adjustment and a stitch length of '0' the walking foot 1 and presser foot 2 should lift 7.0mm above the needle plate when turning the balance wheel.

- ① Adjust the walking foot to maximum and set the stitch length at '0'.
- ② Lower walking foot 1.
- ③ Turn the balance wheel until the presser foot 2 reaches it's highest point.
- ④ Turn crank 3 (screws 4) according to the above rule.
- ⑤ Do a test run.

10) UPPER THREAD TENSION REGULATION (Fig.23)

When the walking foot is high the two tension plates should be at least 0.5mm apart.

- ① Pull the walking foot up using the hand-lever.
- ② Position the pressure plate 1 behind the tension releasing plate 2 according to the above rule.

Note:

- ① The distance of 0.5mm is the minimum measurement and with thick types of thread it can be over 1mm.
- ② Effective tension should not put a strain on the pin 3.

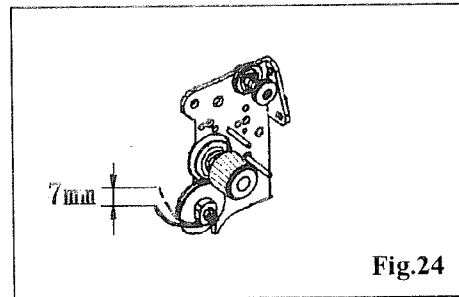
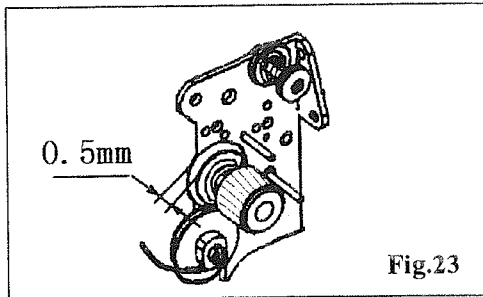

11) THREAD TAKE-UP SPRING (Fig.24)

The thread take-up spring should stop moving when the needlepoint pierces the material (= about 7mm of spring movement)

The length of the thread take-up spring can deviate slightly up or down due to reasons of sewing technique.

12) BOBBIN WINDER (Fig.25)

① When the bobbin winder is activated the spindle should also be activated: When the bobbin winder is deactivated the rubbing wheel 5 should not stand next to the drive wheel

② The bobbin winder should switch itself off when the filled quantity is still 1mm from the edge of the bobbin.

I) Push the drive wheel 1 (screws 2) according to rule 1.

II) Place a bobbin on the bobbinet, thread up the bobbin and switch on the bobbin winder.

III) Tighten bolts 3 (screws 4) according to rule 2.

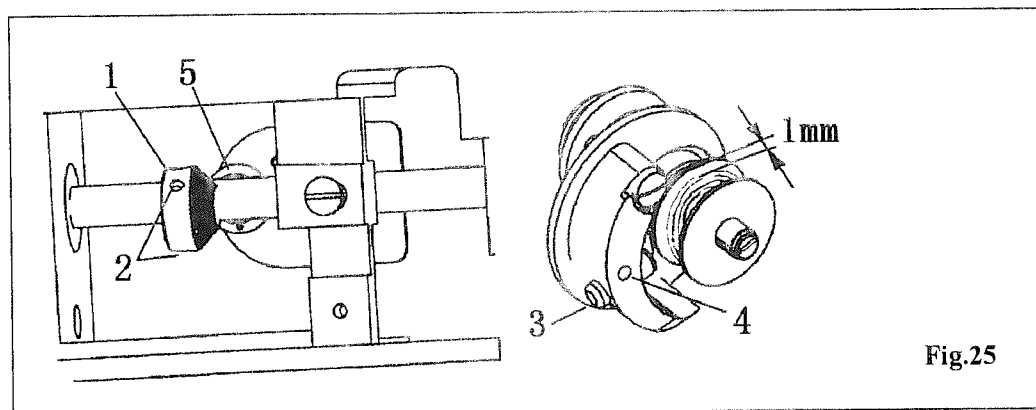

13) Adjustment of Presser Pressure (Fig.26)

The material should move smoothly even at top sewing speed. No pressure should show on the material.

Turn screw 1 according to the above rule.

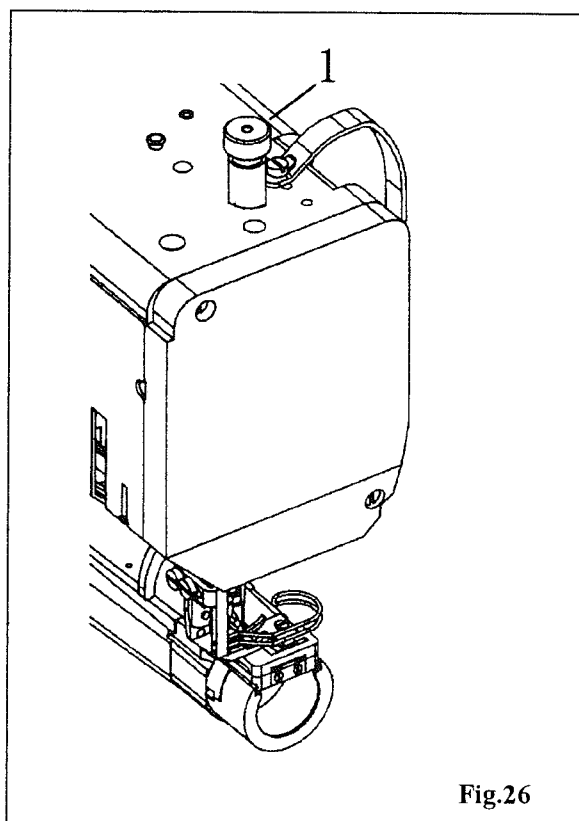
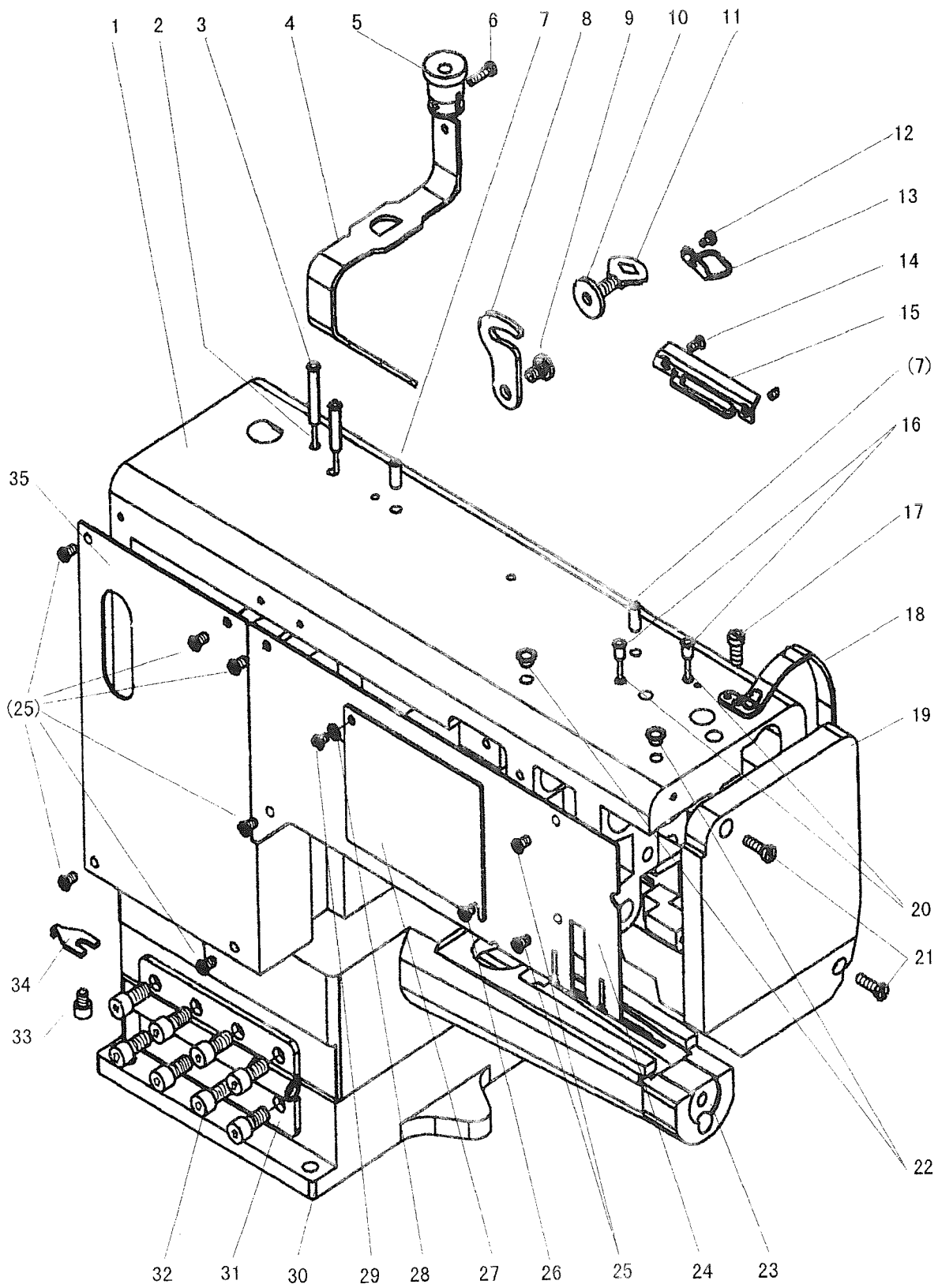

Fig.26

A. ARM BED AND ITS ACCESSORIES (1)



From the library of: Diamond Needle Corp

A. ARM BED AND ITS ACCESSORIES (2)

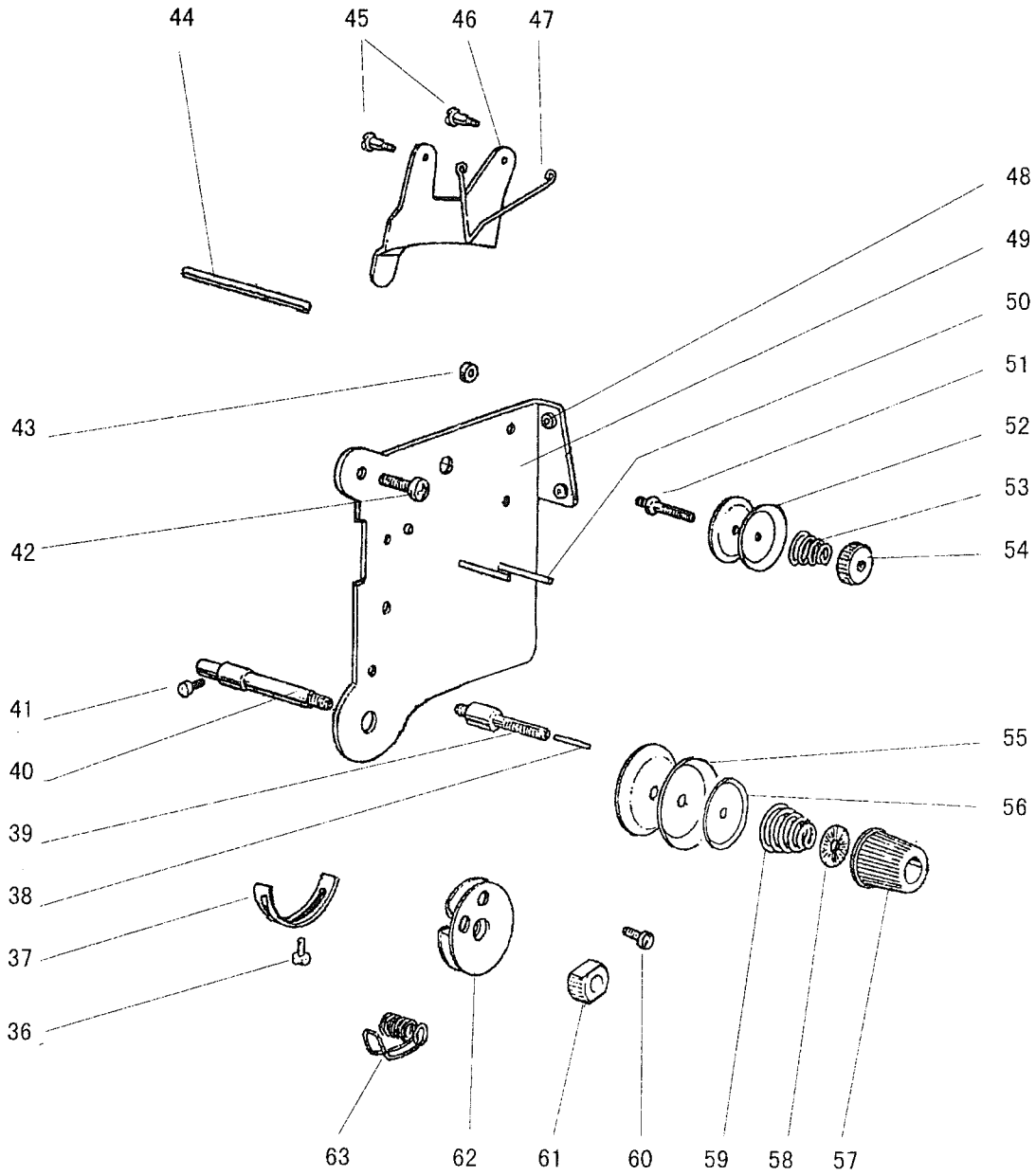

From the library of: Diamond Needle Corp

A. ARM BED AND ITS ACCESSORIES

Fig. No.	Part No.	Description	Pcs.	Remarks
A01	H7307B8001	Arm	1	
A02	H7331B8001	Oil wick	2	
A03	H7330B8001	Oil pipe	2	
A04	H7326B8001	Felt	1	
A05	H7327B8001	Holder	1	
A06	H401040160	Screw	1	GB/T65 M4×16
A07	H7334B8001	Oil pipe	2	
A08	H4100B2060	Link plate	1	
A09	H4100B2070	Screw	1	SM1/4 (24) × 5.7
A10	H4100B2090	Washer	1	
A11	H4100B2080	Screw	1	SM1/4 (24) × 20
A12	HA700B2060	Screw	1	SM11/64 (40) × 8
A13	H7335B8001	Thread guide	1	
A14	H7322B8001	Screw	2	M4×6
A15	H7321B8001	Thread guide	1	
A16	H7328B8001	Oil pipe	2	
A17	HA300C2030	Screw	1	SM11/64 (40) × 8
A18	H3200B2050	Thread take-up cover	1	
A19	H7319B8001	Face plate	1	
A20	H7329B8001	Oil wick	2	
A21	H401050160	Screw	2	GB/T65 M5×16
A22	HA106B0673	Oil cup	2	φ 19
A23	H7309B8001	Arm bed	1	
A24	H7312B8001	Arm side cover (1)	1	
A25	H7314B8001	Screw	8	M5×8
A26	H7316B8001	Screw	1	M4×6
A27	H7315B8001	Cover	1	
A28	H7318B8001	Washer	1	
A29	H7317B8001	Screw	1	M4×4.5
A30	H7311B8001	Supporter	1	
A31	H5350B7101	Hinge	1	
A32	H415080160	Screw	8	GB/T70.1 M8×16
A33	H415060080	Screw	1	GB/T70.1 M6×8
A34	H7338B8001	Holder	1	
A35	H7313B8001	Arm side cover (2)	1	
A36	H3200B2100	Screw	1	SM9/64 (40) × 6.5
A37	H3221B6819	Spring stop	1	
A38	H3221B6817	Pin	1	
A39	H3221B0686	Screw	1	SM1/4 (40) × 14.5
A40	H4805C8001	Thread tension stud	1	SM1/4 (40) × 8.5
A41	H2004J0067	Screw	1	SM9/64 (40) × 7
A42	HA300C2030	Screw	1	SM11/64 (40) × 8
A43	H3221B6810	Nut	1	SM11/64 (40) × 3

A. ARM BED AND ITS ACCESSORIES

Fig. No.	Part No.	Description	Pcs.	Remarks
A44	H3221B6818	Thread releasing pin	1	
A45	H2504C6510	Screw	2	SM9/64 (40) × 3
A46	H3221B3142	Tension releasing plate	1	
A47	H2504C6511	Tension releasing spring	1	
A48	H3221B0681	Porcelain cluct	2	
A49	H3221B6820	Mounting plate	1	
A50	H3221B0682	Pin	2	
A51	H3221B0683	Thread tension stud	1	SM11/64 (40) × 10
A52	HA112B0693	Thread tension disc	2	
A53	H3221B0684	Spring	1	
A54	HA710B0671	Thumb nut	1	SM11/64 (40) × 6
A55	HA310B0705	Thread tension disc	2	
A56	HA310B0702	Thread tension releasing disc	1	
A57	HA310B0701	Thumb nut revolution stopper	1	
A58	HA115B7010	Thumb nut complete	1	
A59	HA115B0703	Spring	1	
A60	H4804C8001	Screw	1	SM9/64 (40) × 2.9
A61	H32481B721	Thumb nut	1	SM1/4 (40) × 4.5
A62	H32481BD21	Plate complete	1	
A63	H4713C8001	Thread take-up spring	1	

B. FEEDING AND FEED LIFTING & ROTATING HOOK SHAFT MECHANISM

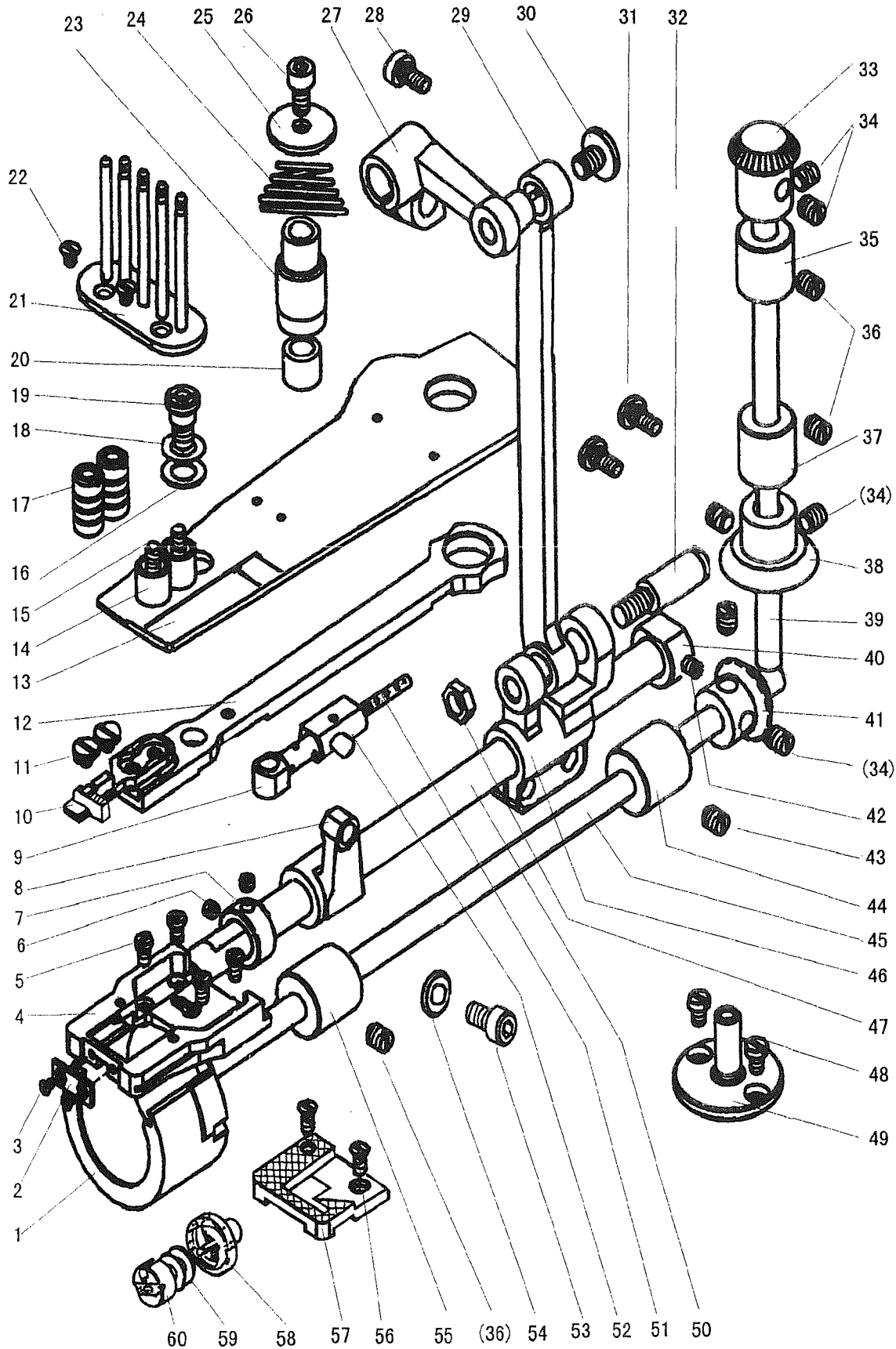

From the library of: Diamond Needle Corp

B. FEEDING AND FEED LIFTING & ROTATING HOOK SHAFT MECHANISM

Fig. No.	Part No.	Description	Pcs.	Remarks
B01	H7310C8001	Stop plate	1	
B02	H7308C8001	Hook positioner	1	
B03	H7309C8001	Screw	2	SM3/32(56)×2.1
B04	H7305C8001	Fixing plate bracket for the needle plate	1	
B05	H4913J8001	Screw	4	SM9/64(40)×4.5
B06	H6039G8001	Set screw	2	SM11/64(40)×3.8
B07	H7345C8001	Feed rock shaft collar (left)	1	
B08	H7347C8001	Feed rock shaft crank (left)	1	
B09	H7349C8001	Feed rock shaft crank (left) joint	1	
B10	H7321C8001	Feed dog	1	
B11	H7322C8001	Screw	2	SM9/64(40)×4
B12	H7324C8001	Feed bar	1	
B13	H7332C8001	Wiggle plate	1	
B14	H7338C8001	Bushing	2	
B15	H7336C8001	Screw	2	SM11/64(40)×14
B16	H7334C8001	Washer	1	
B17	H7337C8001	Nut	2	SM11/64(40)×19
B18	H7335C8001	Washer	1	
B19	H7333C8001	Pin	1	
B20	H7328C8001	Bearing for feed bar holder	2	HK0810
B21	H7339C7101	Mounting plate complete	1	
B22	H7342C8001	Screw	2	SM9/64(40)×3
B23	H7325C8001	Bushing for feed bar holder	1	
B24	H7327C8001	Spring for feed bar holder	1	
B25	H7329C8001	Washer	1	
B26	H415050100	Screw	1	GB/T70.1 M5×10
B27	H7355C8001	Crank	1	
B28	H415080160	Screw	1	GB/T70.1 M8×16
B29	H7354C8001	Connecting rod for feed lifting	1	
B30	H7356C8001	Screw	1	SM1/4(28)×9
B31	H7360C8001	Screw	2	M6×13
B32	H7361C8001	Pin	1	
B33	HA113D2122	Vertical shaft gear (upper)	1	
B34	HA108C0663	Set screw	6	SM1/4(40)×7
B35	H7312C8001	Vertical shaft bushing (upper)	1	
B36	H428060080	Set screw	3	GB/T77 M6×8
B37	H7314C8001	Vertical shaft bushing (lower)	1	
B38	HA113D2222	Vertical shaft gear (lower)	1	
B39	H7311C8001	Vertical shaft	1	
B40	H7344C8001	Feed rock shaft collar (right)	1	
B41	HA113D2212	Rotating hook shaft gear	1	
B42	HA100B2110	Set screw	1	SM11/64(40)×5.5
B43	H2404G0658	Screw	1	SM11/64(32)×7.7

B. FEEDING AND FEED LIFTING & ROTATING HOOK SHAFT MECHANISM

Fig. No.	Part No.	Description	Pcs.	Remarks
B44	H7316C8001	Rotating hook shaft bushing (right)	1	
B45	H7315C8001	Rotating hook shaft	1	
B46	H7359C8001	Feed rock shaft crank (right)	1	
B47	H7362C8001	Nut	1	SM1/4(28)×3.7
B48	H7330C8001	Screw	2	M4×6
B49	H7326C8001	Feed bar holder	1	
B50	H7343C8001	Feed rock shaft	1	
B51	H7353C8001	Oil wick	1	
B52	H7352C8001	Bracket	1	
B53	H415040080	Screw	1	GB/T70.1 M4×8
B54	H7351C8001	Washer	1	
B55	H7317C8001	Rotating hook shaft bushing (left)	1	
B56	H7307C8001	Screw	2	SM9/64(40)×6
B57	H7306C8001	Needle plate	1	
B58	H3004E0065	Rotating hook	1	GC2698-1
B58	H7365C8001	Rotating hook	1	GC2698-1B
B59	HA100E2170	Bobbin	1	GC2698-1
B59	H7363C8001	Bobbin	1	GC2698-1B
B60	H3005E0066	Bobbin sheath	1	GC2698-1
B60	H7364C8001	Bobbin sheath	1	GC2698-1B

C. ARM SHAFT MECHANISM

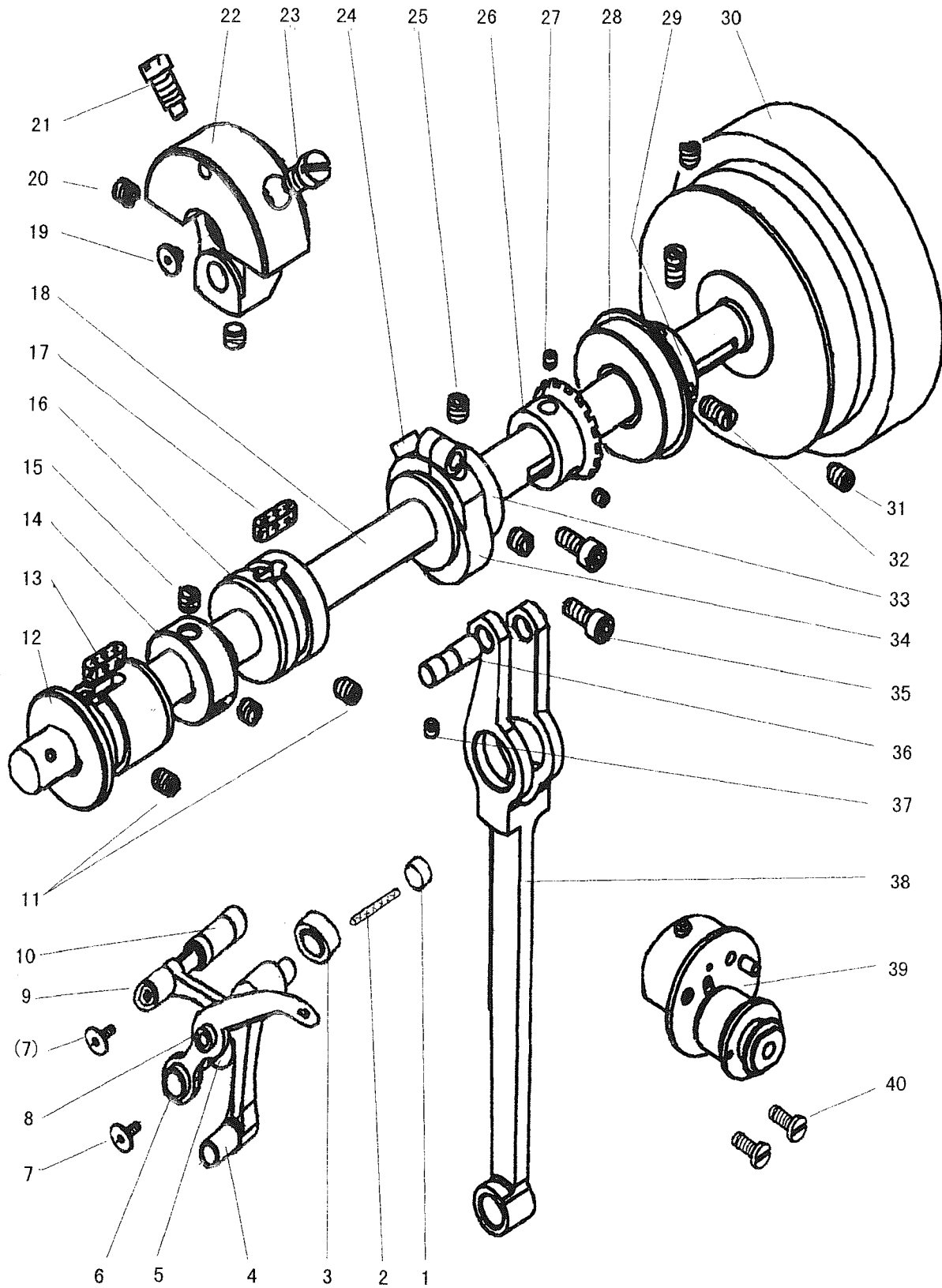

From the library of: Diamond Needle Corp

C: ARM SHAFT MECHANISM

Fig. No.	Part No.	Description	Pcs.	Remarks
C01	H7354D8001	Rubber plug	1	
C02	H7355D8001	Oil wick	1	
C03	H7358D8001	Bearing	1	K9×12×13T2
C04	H7352D8001	Link	1	
C05	H7353D8001	Crank	1	
C06	H7348D8001	Thread take-up lever	1	
C07	H7351D8001	Screw	2	SM9/64 (40) × 7
C08	H7359D8001	Bearing	1	K7×10×8T2
C09	H7349D8001	Link for thread take-up	1	
C10	H7350D8001	Pin	1	
C11	H428060080	Screw	2	GB/T77 M6×8
C12	H7320D8001	Arm shaft bushing (left)	1	
C13	H7321D8001	Felt	1	
C14	H7324D8001	Wheel for bobbin winder	1	
C15	HA108C0662	Screw	2	SM1/4 (40) × 6
C16	H7322D8001	Arm shaft bushing (middle)	1	
C17	H7323D8001	Felt	1	
C18	H7318D8001	Arm shaft	1	
C19	H7319D8001	Arm shaft Plug	1	
C20	HA307C0662	Screw	2	SM1/4 (40) × 6
C21	HA100C2070	Screw	1	SM9/32 (28) × 10
C22	H7357D8001	Needle bar crank	1	
C23	HA100C2060	Screw	1	SM9/32 (28) × 13
C24	H7309D8001	Bracket for feed cam crank	1	
C25	HA108C0663	Screw	2	SM1/4 (40) × 7
C26	HA113D2112	Bevel gear for arm shaft	1	
C27	HA108C0663	Screw	2	SM1/4 (40) × 7
C28	H3208H0661	Bearing	1	6004ZZNR
C29	H5336C8001	Arm shaft bushing (right)	1	
C30	H2000C2040	Balance wheel	1	
C31	HA110D0672	Screw	2	SM15/64 (28) × 12
C32	HA113F0684	Screw	2	SM15/64 (28) × 8.5
C33	H7305D8001	Feed cam	1	
C34	H7308D8001	Cover for feed cam crank	1	
C35	H415050120	Screw	2	GB/T70.1 M5×12
C36	H7311D8001	Pin	1	
C37	H428040040	Screw	1	GB/T77 M4×4
C38	H7313D8001	Connecting rod for feed cam crank	1	
C39	H7325D7101	Bobbin winder assy	1	
C40	H401040060	Screw	2	GB/T65 M4×6

D. STITCH REGULATOR MECHANISM

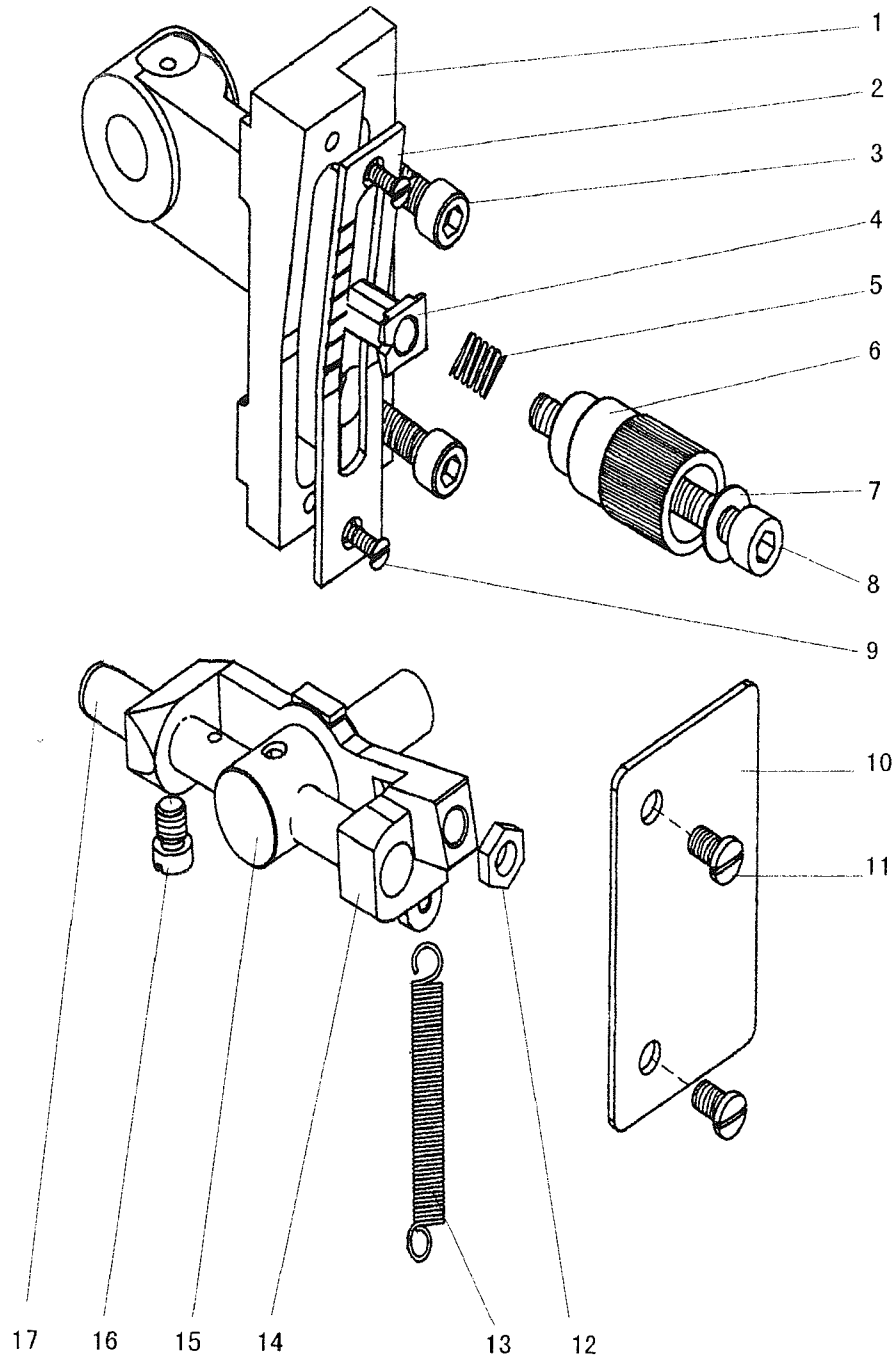

From the library of: Diamond Needle Corp

D. STITCH REGULATOR MECHANISM

Fig. No.	Part No.	Description	Pcs.	Remarks
D01	H7305E8001	Bracket for stitch length plate	1	
D02	H7307E8001	Stitch length plate	1	
D03	H415060160	Screw	2	GB/T70.1 M6×16
D04	H7315E8001	Guide bushing	1	
D05	H7313E8001	Spring	1	
D06	H7310E7101	Stitch length regulating nut assy	1	
D07	H7314E8001	Washer	1	
D08	H7312E8001	Stud	1	M6×60
D09	H4100F2070	Screw	2	SM9/64(40)×7
D10	H7325E8001	Cover	1	
D11	H7326E8001	Screw	2	M5×7.5
D12	H7316E8001	Feed regulator screw bar	1	
D13	H7323E8001	Spring	1	
D14	H7318E8001	Setting frame	1	
D15	H7324E8001	Guide bushing	1	
D16	H7322E8001	Screw	1	SM15/64(40)×7.5
D17	H7319E7101	Pin	1	

E. PRESSER FOOT MECHANISM

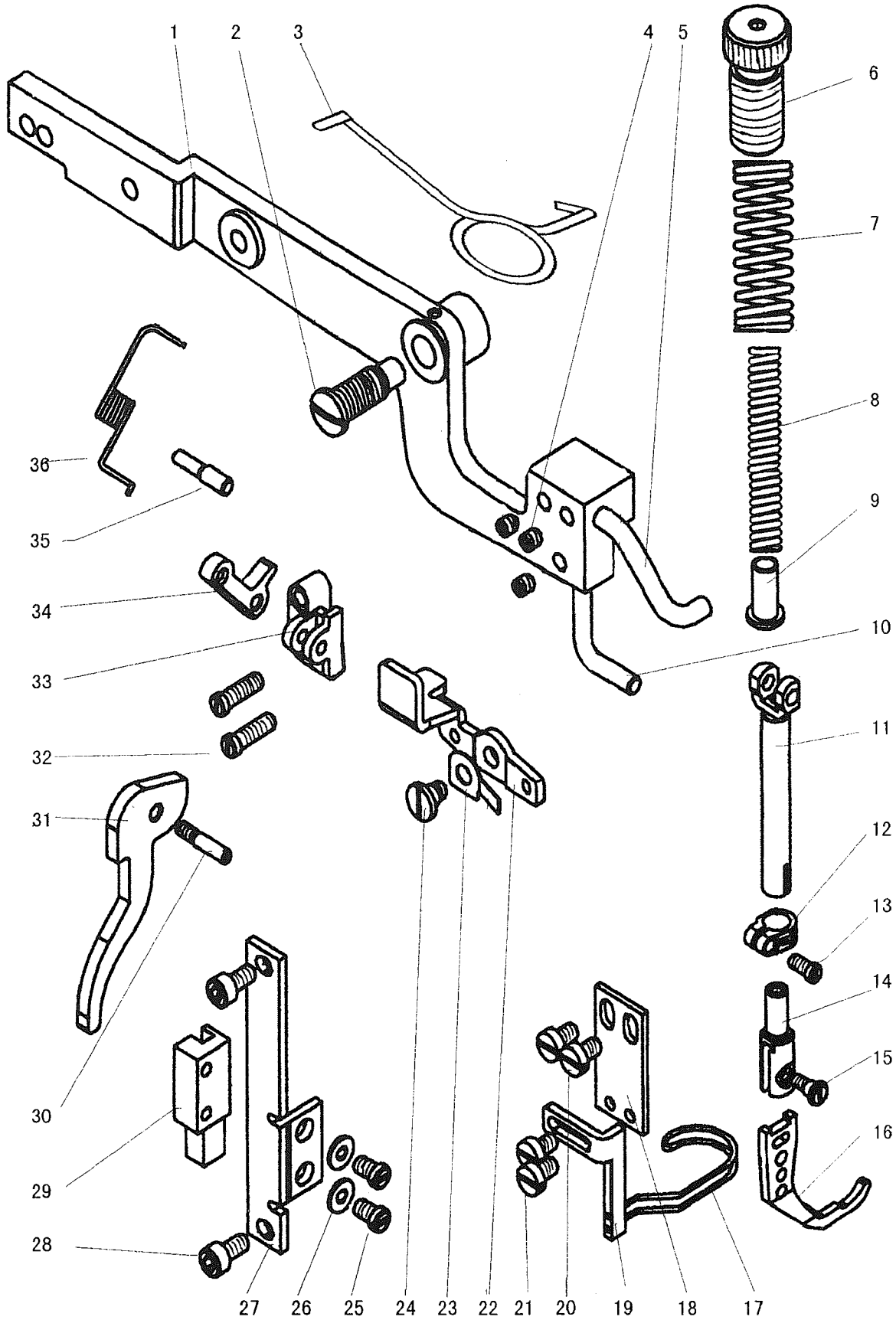

From the library of: Diamond Needle Corp

E. PRESSER FOOT MECHANISM

Fig. No.	Part No.	Description	Pcs.	Remarks
E01	H7307F8001	Knee lifter lever	1	
E02	H7311F8001	Screw	1	M8×10
E03	H7312F8001	Spring	1	
E04	H7310F8001	Screw	3	M5×5
E05	H7308F8001	Stop bar for knee lifter lever	1	
E06	H7330F8001	Thumb screw	1	SM5/8" (28) × 39
E07	H7331F8001	Spring	1	
E08	H7332F8001	Spring	1	
E09	H7333F8001	Pipe	1	
E10	H7309F8001	Stop bar for knee lifter lever	1	
E11	H7324F8001	Vibrating presser bar	1	
E12	H7326F8001	Connecting stud for vibrating presser bar	1	
E13	H7327F8001	Screw	1	M4×8
E14	H7325F8001	Connecting stud for walking foot	1	
E15	H7329F8001	Screw	1	SM9/64 (40) × 5.8
E16	H7328F8001	Walking foot	1	
E17	H7335F8001	Walking foot guard cover	1	
E18	H7336F8001	Walking foot guard cover plate	1	
E19	H7337F8001	Walking foot guard cover bracket	1	
E20	H7342F8001	Screw	2	M5×8
E21	H7343F8001	Screw	2	M4×6
E22	H7320F8001	Thread releasing disc	1	
E23	H7321F8001	Spring	1	
E24	H7322F8001	Screw	1	M5×4
E25	H454040100	Screw	2	GB66016 M4×10
E26	H005001040	Washer	2	GB/T97.1 4
E27	H7341F8001	Mounting frame	1	
E28	H415050100	Screw	2	GB/T70.1 M5×10
E29	H7339F8001	Walking foot guide plate	1	
E30	H7305F8001	Presser bar lifter	1	M4×8
E31	H7304F8001	Presser bar lifter	1	
E32	H7315F8001	Screw	2	M5×16
E33	H7314F8001	Bracket for knee lifter lever	1	
E34	H7316F8001	Knee lifter lever crank	1	
E35	H7317F8001	Pin	1	
E36	H7318F8001	Spring	1	

F. NEEDLE BAR FEEDING MECHANISM (1)

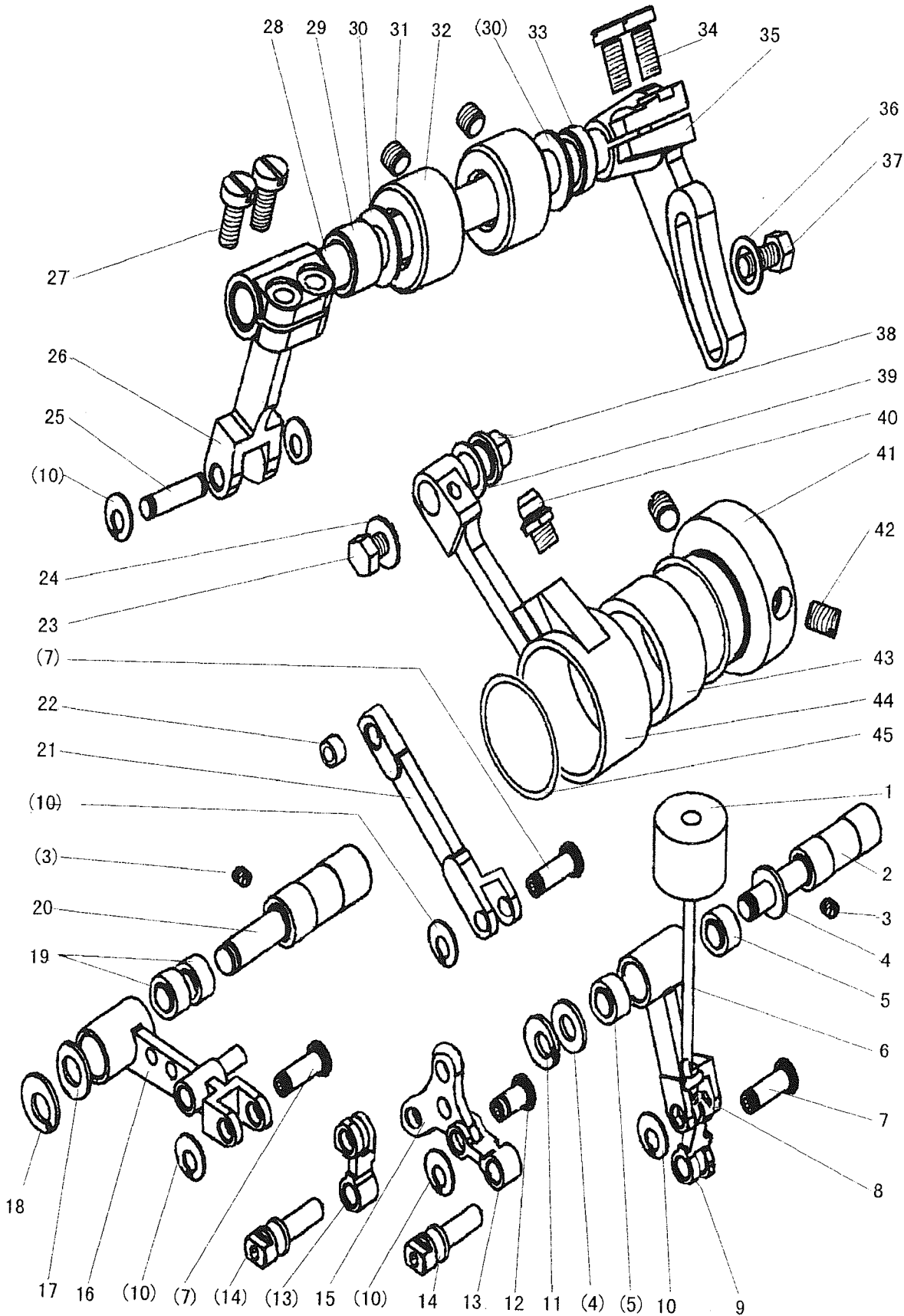

From the library of: Diamond Needle Corp

F. NEEDLE BAR FEEDING MECHANISM (2)

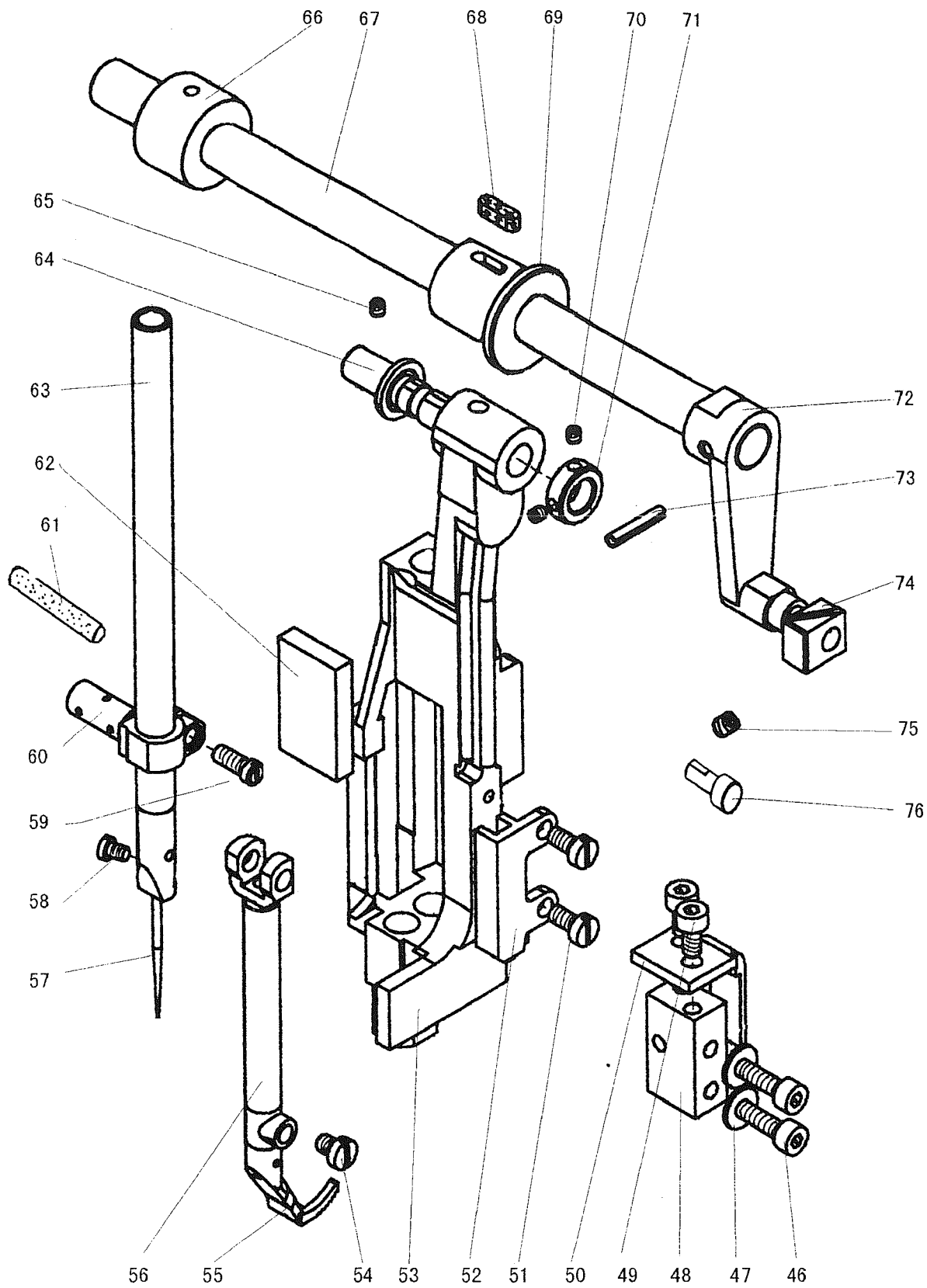

F. NEEDLE BAR FEEDING MECHANISM

Fig. No.	Part No.	Description	Pcs.	Remarks
F01	H7359G8001	Felt	1	
F02	H7361G8001	Pin	1	
F03	H428060080	Screw	2	GB/T77 M6×8
F04	H7362G8001	Washer	2	
F05	H7365G8001	Bearing	2	K6×9×8T2
F06	H7356G7101	Spring guide bar	1	
F07	H7337G8001	Pin	3	
F08	H7360G8001	Connecting rod	1	
F09	H7355G8001	Connecting rod	1	
F10	H007009050	Stop ring	6	GB/T894.1 5
F11	H007009060	Stop ring	1	GB/T894.1 6
F12	H7335G8001	Pin	1	
F13	H7333G8001	Connecting rod	2	
F14	H7334G8001	Slide block	2	
F15	H7336G8001	Crank	1	
F16	H7338G7101	Connecting rod complete	1	
F17	H7342G8001	Washer	1	
F18	H007009070	Stop ring	1	GB/T894.1 7
F19	H7359D8001	Bearing	2	K7×10×8T2
F20	H7341G8001	Pin	1	
F21	H7343G8001	Connecting rod	1	
F22	H7376G8001	Bearing	1	K5×8×8T2
F23	H453050080	Screw	1	GB30004 M5×8
F24	H7314G8001	Washer	1	
F25	H7344G8001	Pin	1	
F26	H7346G8001	Connecting rod	1	
F27	H7377G8001	Screw	2	M5×12
F28	H7347G8001	Upper feed lifting rock shaft	1	
F29	H7352G8001	Bushing (left)	1	
F30	H7353G8001	Washer (left)	2	
F31	H428060050	Screw	2	GB/T77 M6×5
F32	H7348G7101	Bushing for upper feed lifting rock shaft	2	
F33	H7354G8001	Bushing (right)	1	
F34	H7312G8001	Screw	2	M5×11.7
F35	H7311G8001	Regulating crank	1	
F36	H005001050	Washer	1	GB/T97.1 5
F37	H102050100	Screw	1	GB/T5781 M5×10
F38	H7313G8001	Pin	1	
F39	H7315G8001	Washer	1	
F40	HD00001060	Oil cup	1	JB/T7940.1 M6
F41	H7305G8001	Cam for presser foot lifting	1	
F42	H455060080	Screw	2	GB74031 M6×8
F43	H7316G8001	Bearing	1	K24×29×13

F. NEEDLE BAR FEEDING MECHANISM

Fig. No.	Part No.	Description	Pcs.	Remarks
F44	H7309G8001	Connecting rod	1	
F45	H7308G8001	Stop ring	2	
F46	H415040160	Screw	2	GB/T70.1 M4×16
F47	H005001040	Washer	2	GB/T97.1 4
F48	H7364G8001	Guide plate for needle bar rock frame	1	
F49	H415040080	Screw	2	GB/T70.1 M4×8
F50	H7366G8001	Fixing plate	1	
F51	H7378G8001	Screw	2	M4×8
F52	H7368G8001	Guide plate for slide block	1	
F53	H7320G8001	Needle bar rock frame	1	
F54	H7331G8001	Screw	1	M4×5.5
F55	H7330G8001	Presser foot	1	
F56	H7329G8001	Presser bar	1	
F57	H7317G8001	Needle	1	DP×35LR 14#-16#
F58	H3204D6510	Screw	1	SM1/8(44)×4
F59	H7327G8001	Screw	1	M4×10
F60	H7326G8001	Needle bar connecting stud	1	
F61	H7328G8001	Oil wick	1	
F62	H7321G8001	Felt	1	
F63	H7324G8001	Needle bar	1	
F64	H7322G8001	Pin for rock frame	1	
F65	H428050080	Screw	1	GB/T77 M5×8
F66	H7373G8001	Bushing	1	
F67	H7370G8001	Needle bar rock shaft	1	
F68	H7367G8001	Felt	1	
F69	H7371G8001	Bushing	1	
F70	H456030030	Screw	2	GB74001 M3×3
F71	H7323G8001	Collar	1	
F72	H7372G8001	Needle bar rock shaft crank	1	
F73	H602030160	Pin	1	GB/T117 3×16 (A型)
F74	H7374G8001	Square block	1	
F75	H7310F8001	Screw	1	M5×5
F76	H7375G8001	Spring stop	1	

G. ACCESSORIES

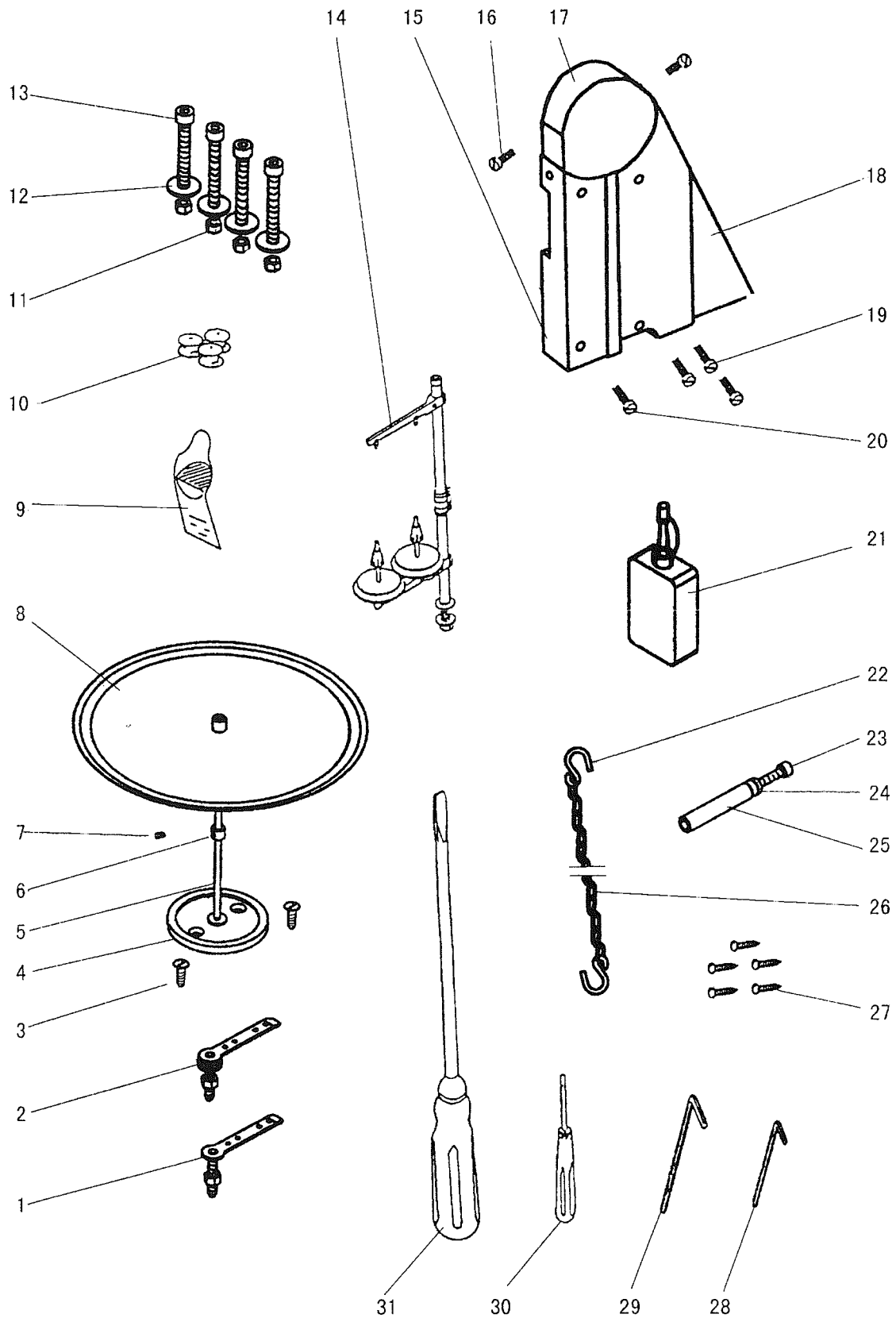

From the library of: Diamond Needle Corp

G. ACCESSORIES

Fig. No.	Part No.	Description	Pcs.	Remarks
G01	H7308H7101	Thread stand assay	1	
G02	H7311H7101	Bobbin winder assay	1	
G03	H801055250	Wood screw	2	GB/T99 5.5×25
G04	H7326H8001	Seat	1	
G05	H7323H8001	Shelf	1	
G06	H7324H8001	Collar	1	
G07	H7325H8001	Screw	1	SM9/64(40)×3
G08	H7320H7101	Plate complete	1	
G09	H7317G8001	Needle	4	DP×35LR 14#-16#
G10	HA100E2170	Bobbin	3	
G11	H003002080	Nut	4	GB/T6170 M8
G12	H005006080	Washer	4	GB/T96 8
G13	H415080600	Screw	4	GB/T70.1 M8×60
G14	HA200J2030	Thread guide	1	GXJ-2
G15	H7328H8001	Belt cover (left)	1	
G16	H2000O0360	Screw	2	SM11/64(40)×6
G17	H6307L8001	Belt cover (upper)	1	
G18	H7327H8001	Belt cover (right)	1	
G19	HA300J2280	Screw	3	SM15/64(28)×8
G20	H2400K0160	Screw	1	SM15/64(28)×8
G21	H2004O0069	Oil tank	1	
G22	HPG100E202	Pothook	2	
G23	H415060800	Screw	1	GB/T70.1 M6×80
G24	H007013090	Stop ring	2	GB/T896 9
G25	H7315H8001	Bushing	1	
G26	HPG100E203	Chain	1	L=950
G27	H801045200	Wood screw	5	GB/T99 4.5×20
G28	HS68990206	Socket wrench	1	5mm
G29	HS68990207	Socket wrench	1	6mm
G30	HA300J2210	Screw driver (small)	1	
G31	HA300J2070	Screw driver (larger)	1	

SHANGHAI HUIGONG NO.3 SEWING MACHINE FACTORY

ADD: 1418, Yishan Road, Shanghai, China

Zip Code: 201103

Overseas Business: TEL: 86-21-64853303 FAX: 86-21-64854304

E-mail: highlead@online.sh.cn <http://www.highlead.com.cn>

The description covered in this manual is subject to change for improvement of the commodity without notice

2003.12. Printed