

HIGHLEAD

GC24618 series

**Single/Double Needle Post-bed Compound Feed Lockstitch
Sewing Machine With Roller**

Instruction Manual Parts Catalog

SHANGHAI HUIGONG NO.3 SEWING MACHINE FACTORY

---- CONTENTS ----

INSTRUCTION BOOK

Instruction for GC24618/GC24618-1	1
Trouble shooting and remedy	6

PARTS CATALOG

A、 ARM BED AND ITS ACCESSORIES	7
B、 THREAD TENSION MECHANISM.....	9
C、 BEARING SHAFT MECHANISM	11
D、 ROLLER PRESSER FOOT MECHANISM.....	13
E、 THREAD TAKE-UP MECHANISM	15
F、 UPPER SHAFT MECHANISM	17
G、 UPPER SIDE SHAFT MECHANISM.....	19
H、 NEEDLE BAR MECHANISM.....	21
I、 NEEDLE BAR FEEDING MECHANISM	23
J、 PRESSER BAR MECHANISM.....	25
K、 TIMING BELT DRIVING MECHANISM	27
L、 STITCH REGULATOR MECHANISM	29
M、 FEED MECHANISM.....	31
N、 CLUTCH MECHANISM	33
O、 CENTRAL POST BED MECHANISM FOR SINGLE NEEDLE	35
P、 GEAR DRIVING MECHANISM FOR SINGLE NEEDLE	37
Q、 LEFT AND MIDDLE POST BED MECHANISM FOR TWO NEEDLE	39
R、 LEFT POST MECHANISM FOR SINGLE NEEDLE	41
S、 RIGHT POST BED MECHANISM	44
T、 BEARING DRIVING MECHANISM	46
U、 RIGHT POST BED DRIVING MECHANISM.....	48
V、 ACCESSORIES(1).....	50
W、 ACCESSORIES(2).....	52
X、 PRESSER FOOT FOR GC24618-1	54

SPECIAL PARTS CATALOG FOR GC24618-D/GC618-1D

Y、 THREAD TENSION MECHANISM	56
Z1、 KNIFE ACTUATING MECHANISM(1).....	57
Z2、 KNIFE ACTUATING MECHANISM(2).....	59

GC24618 SERIES POST-BED COMPOUND FEED LOCKSTITCH SEWING MACHINE WITH ROLLER INSTRUCTION BOOK

Thank you for choosing GC24618 series Post-bed compound feed lockstitch sewing machine with roller.

This is an instruction book & parts catalog, which will help you to use machine and maintain the machine correctly while facilitate reference of parts.

In order to avoid trouble, please read this instruction book carefully before operation, and accept safety operation guide from professionals.

1. BRIEF INTRODUCTION OF MACHINE

GC24618 (Single needle) / GC24618-1 (double needle) post-bed compound feed lockstitch sewing machine with roller is elegant in appearance, nice and even in stitches which can be freely adjusted, light and smooth in running with ball bearing and needle bearing, excellent for heavy duty with wheel feed and driven roller presser foot, and is especially suitable for sewing high-grade leather shoes, bags, gloves and other curvy leather products.

2. MAIN SPECIFICATIONS

Type	GC24618/GC24618-1
Max Sewing Speed	2500rpm
Stitch Length	1.3 ~ 7mm
Presser Foot Lift	7 mm.(by hand)
	14mm.(by knee)
Needle Bar Stroke	41mm
Needle	DP×5 11#~20#
Hook	Vertical Hook
Max Thickness to be Sewn	6mm
Lubrication	Manual
Motor	370W Clutch Motor

3. PRECAUTION

- a. Though each machine has been strictly inspected and tested before leaving factory, the machine parts may be loose or deformed after long distance transportation with jolt. So before installing & using the machine, you must check it carefully. Examine it and ensure there is no trouble for rotating, on colliding, no abnormal resistance and abnormal sound before you perform run-in operation.

- b. The thread guide way of the parts such as rotating hook, feeding wheel and thread tension regulator assy. etc. is apt to accumulate dust, which would affect sewing performance. So you must clean it regularly.
- c. After you clean the machine, please lubricate all the relevant points with sewing machine oil.
- d. If special sewing material or special thread is used, or you want to replace those parts which will affect clearance, please refer to the professionals.

4. NEEDLE SETTING (Fig.1)

Please use DP×5、11#~20# needle only. Needle should be selected as per thread and nature of material to be sewn. When installing needle, make sure the needle's long groove(A) facing the operator's left side, then fully insert the needle shank up to the bottom of the needle socket and tighten the clamp screw finally.

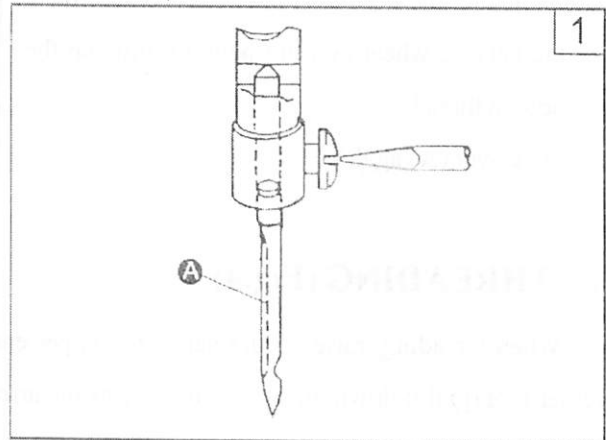

5. WIND THE BOBBIN (Fig.2)

Put Bobbin (B) on the bobbin winder spindle, and draw the thread (A) from spool and between two tension discs (E), then wind the thread on Bobbin (B) several rounds, pull up Bobbin Winder Lever (D), press Spring Plate (C) up to Bobbin (B). When sewing, it will wind the bobbin automatically. (if not sewing, it can wind the bobbin with the presser foot lifted up.)

After winding, you may cut bobbin thread by winding the thread two rounds on the thread cutting blade and pull it off.

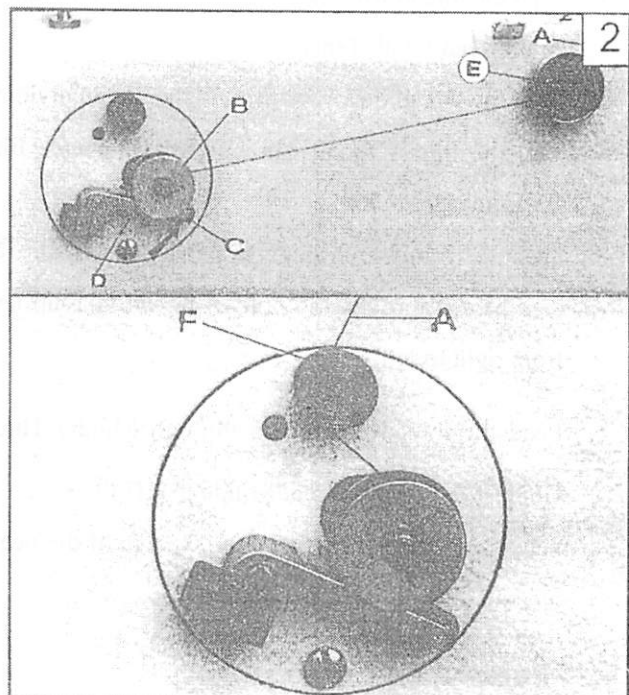

6. INSTALL BOBBIN & BOBBIN CASE (Fig.3)

- a. Open Cover (A).
- b. Lift up Bobbin Latch (B).
- c. Pull bobbin thread out about 50mm, then draw the end of thread through the slot of bobbin case.
- d. Put the bobbin case into the rotating hook.
- e. Press down Bobbin Latch (B).
- f. While taking the needle thread by left hand, rotate the balance wheel by right hand to draw up the bobbin thread.
- g. Close Cover (A) again.

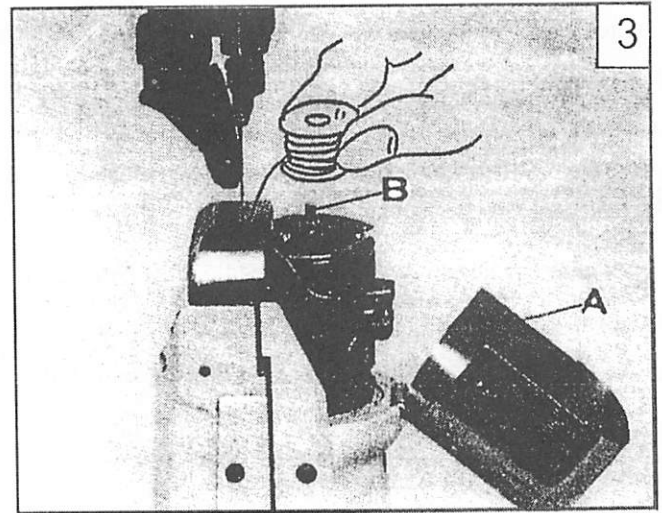

7. THREADING (Fig.4)

When threading, raise needle bar to the upper end of its stroke, lift up presser foot, sewing out the roller presser foot (pull it down, then push it away as the arrow indicates). Then lead the end of thread from spool and start threading in the following sequence:

- a. Lead the thread through the two holes of Thread Pin ①.
- b. Lead the thread from right to left through the right hole of the thread tension setting plate, then lead it up and go between Small Tension discs ②.
- c. Lead the thread downward round the thread dividing pin and pass it through Tension Discs ③.
- d. Pass the thread round Thread Tension Guide Plate ④ from right to left.
- e. Lead the thread up through Upper Thread Guide ⑤, then pass it through the hole of thread take-up lever from right to left.
- f. Lead the thread downward through Middle Thread Guide ⑥, Lower Thread Guide ⑦, Hole ⑧ on the needle bar, then pass it through the eye of the needle ⑨, and draw it out about 100mm for sewing.

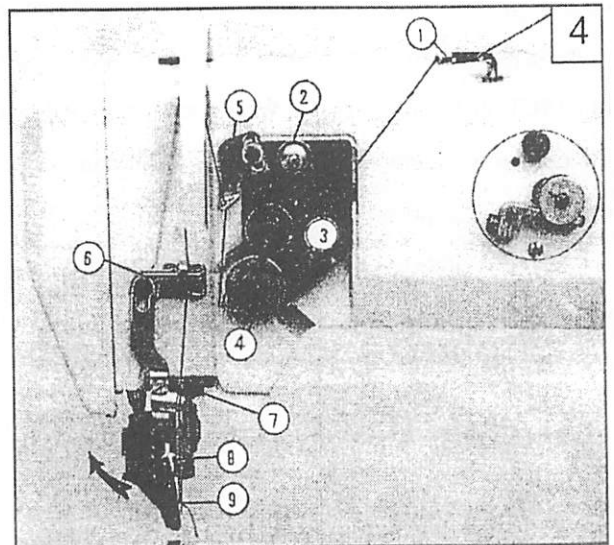

8. ADJUST THREAD TENSION (Fig.5、 6、 7)

The normal stitch should be the same as Fig. (A) shows. If the stitch is abnormal, thread breaking or puckering may appear. In this case, you should adjust the tension of needle thread & bobbin thread until the stitch is right.

- a. If the stitch is the same as Fig. (B) shows, it means needle thread tension is too strong or bobbin thread tension is too weak. You should turn tension nut counter-clockwise to reduce the tension of needle thread. Or tighten Adjusting Screw (B) with small screwdriver to increase the tension of bobbin thread.
- b. Fig. (C) show that needle thread tension is too weak or bobbin thread tension is too strong. You should turn tension nut clockwise to increase the tension of needle thread, or loosen Adjusting Screw (B) using small screwdriver to reduce the tension of bobbin thread.

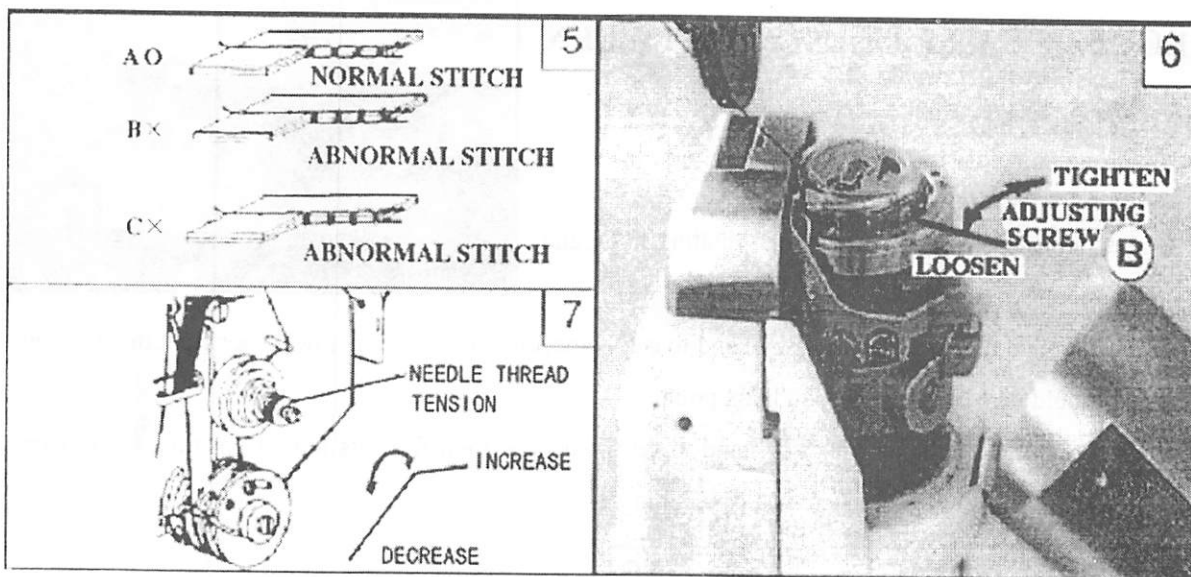

9. ADJUST PRESSURE OF ROLLER PRESSER FOOT (Fig.8)

The presser of the roller presser foot should be adjusted according to the thickness of material to be sewn. When sewing heavy weight material, the pressure of presser foot should be increased by turning clockwise the regulating screw on the back of the machine head as Fig.8 indicates.

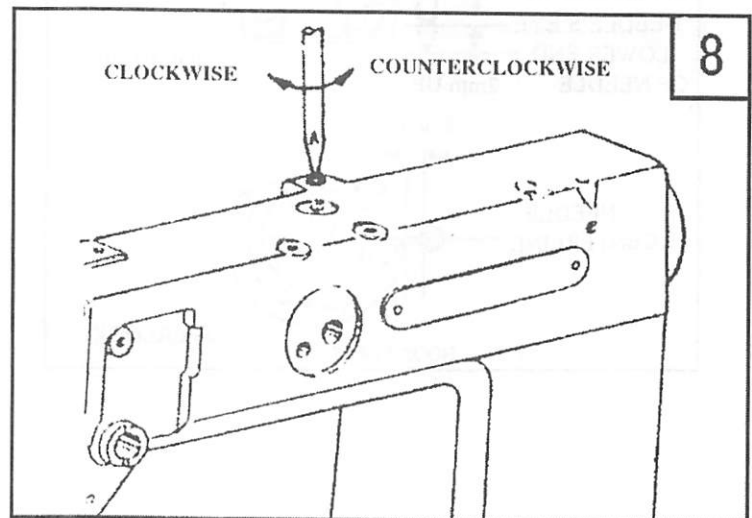

10. ADJUST STITCH LENGTH (Fig.9)

- Press down the stitch regulating button (B) by forefinger of left hand.
- Turn Balance Wheel (A) slowly by right hand.
- Stitch length can be adjusted after the stitch regulating button is depressed.
- The figure of stitch length is indicated on Balance Wheel (A), the bigger this figure is, the longer the stitch is. Turn round the balance wheel till the desired stitch length aims at Reference point (C), then release Stitch Regulating Button (B).

11. REGULATE CLEARANCE BETWEEN HOOK AND NEEDLE (Fig.10)

We suggest adjust the clearance between rotating hook and needle by professionals.

- When turning round the balance wheel by hand to set the needle 2mm from its lowest position, the position of needle's eye should be 1.6mm lower than hook point.
- When turning round the balance wheel by hand to set the needle 2mm from its lowest position, hook point should aim at needle groove with the clearance of 0.05mm.

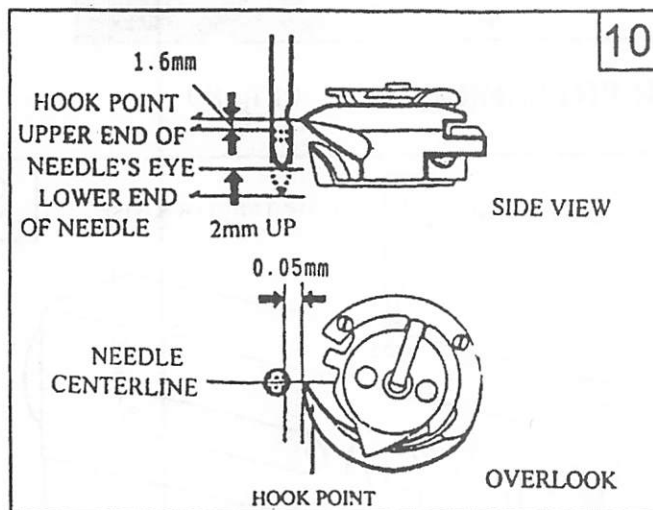
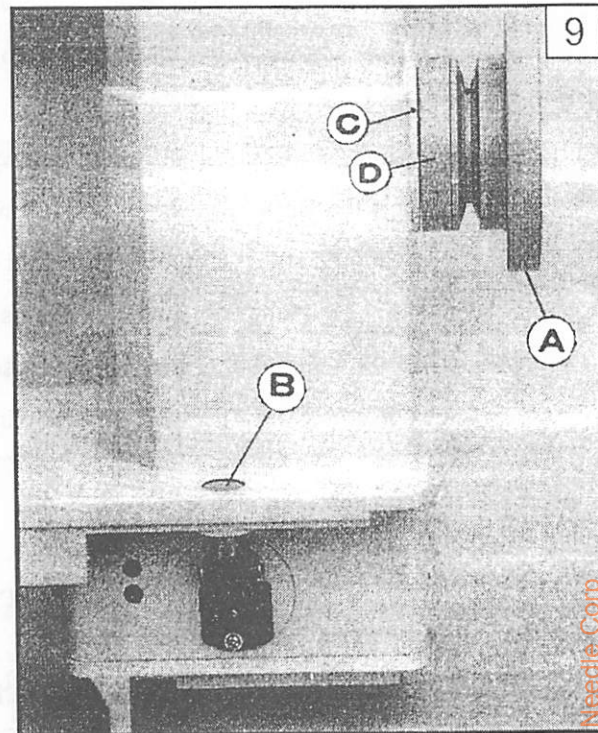

12.TROUBLE SHOOTING AND REMEDY

TROUBLE	CAUSE	REMEDY
Stitch Skipping	<p>(1)Caused by needle: Needle bent Needle doesn't fit for thread.</p> <p>(2)Wrong needle installation: Insufficient insertion.</p> <p>The needle deflected when being inserted</p>	<p>Replace needle Replace with a needle which is fit for thread.</p> <p>Fully insert the needle shank up to the bottom of the needle socket. Re-install needle.</p>
Poor Stitches	<p>(1) Tension of needle thread is too weak.</p> <p>(2) Tension of thread take-up spring is too weak.</p> <p>(3) Tension of bobbin thread is too strong.</p>	<p>Turn tension nut clockwise to adjust tension of needle thread.</p> <p>Adjust the tension of thread take-up spring.</p> <p>Tighten the screw of thread tension spring of bobbin case.</p>
Thread Breaking	<p>(1)Poor-quality thread.</p> <p>(2)Caused by needle: Needle bent Wrong needle installation Needle is not fit for thread</p> <p>(3)The tension of needle thread is too strong</p>	<p>Replace thread with high-quality one.</p> <p>Replace the needle. Re-install the needle. Replace with a needle which is fit for thread.</p> <p>Loosen tension nut.</p>

A. ARM BED AND ITS ACCESSORIES

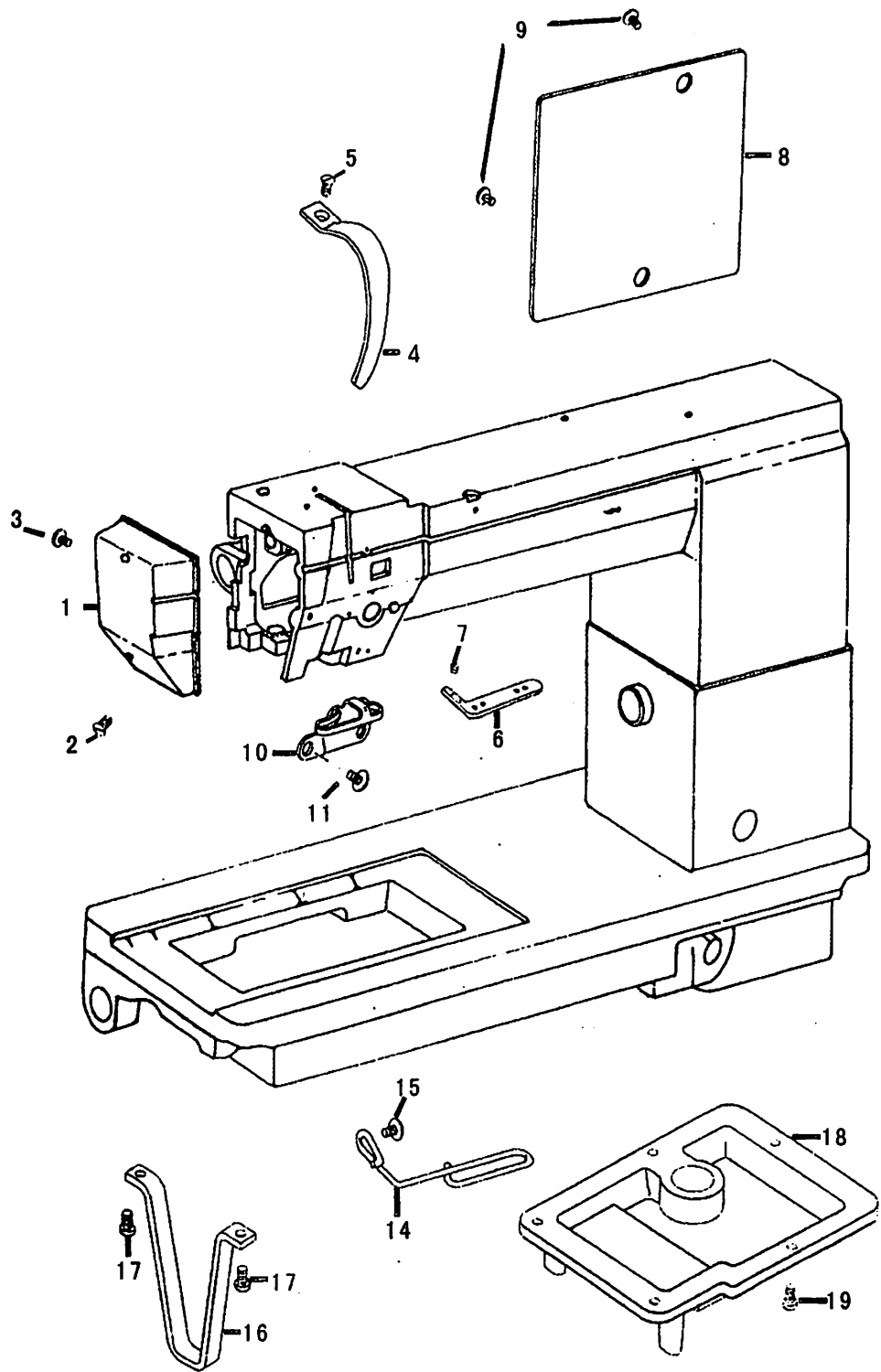

From the library of: Diamond Needle Corp

A. ARM BED AND ITS ACCESSORIES

Ref. No.	Part No.	Name of part	GC24618	GC24618-1	Remarks
1	119687	Face plate	1	1	
2	108246	Screw	1	1	
3	108234	Screw	1	1	
1	168061	Thread take-up cover	1	1	
5	210210	Screw	1	1	
6	119027	4 hole thread retainer	1	1	
7	314946	Screw	1	1	
8	119039	Arm side cover	1	1	
9	700335	Screw	2	2	
10	118430	Thread guide wire	1	1	
11	700335	Screw	1	1	
14	119686	Thread guide wire	1	1	
15	700335	Screw	1	1	
16	119092	bracket	1	1	
17	108285-1	Screw	2	2	
18	119091	Bottom pan	1	1	
19	108225	Screw	5	5	

B. THREAD TENSION MECHANISM

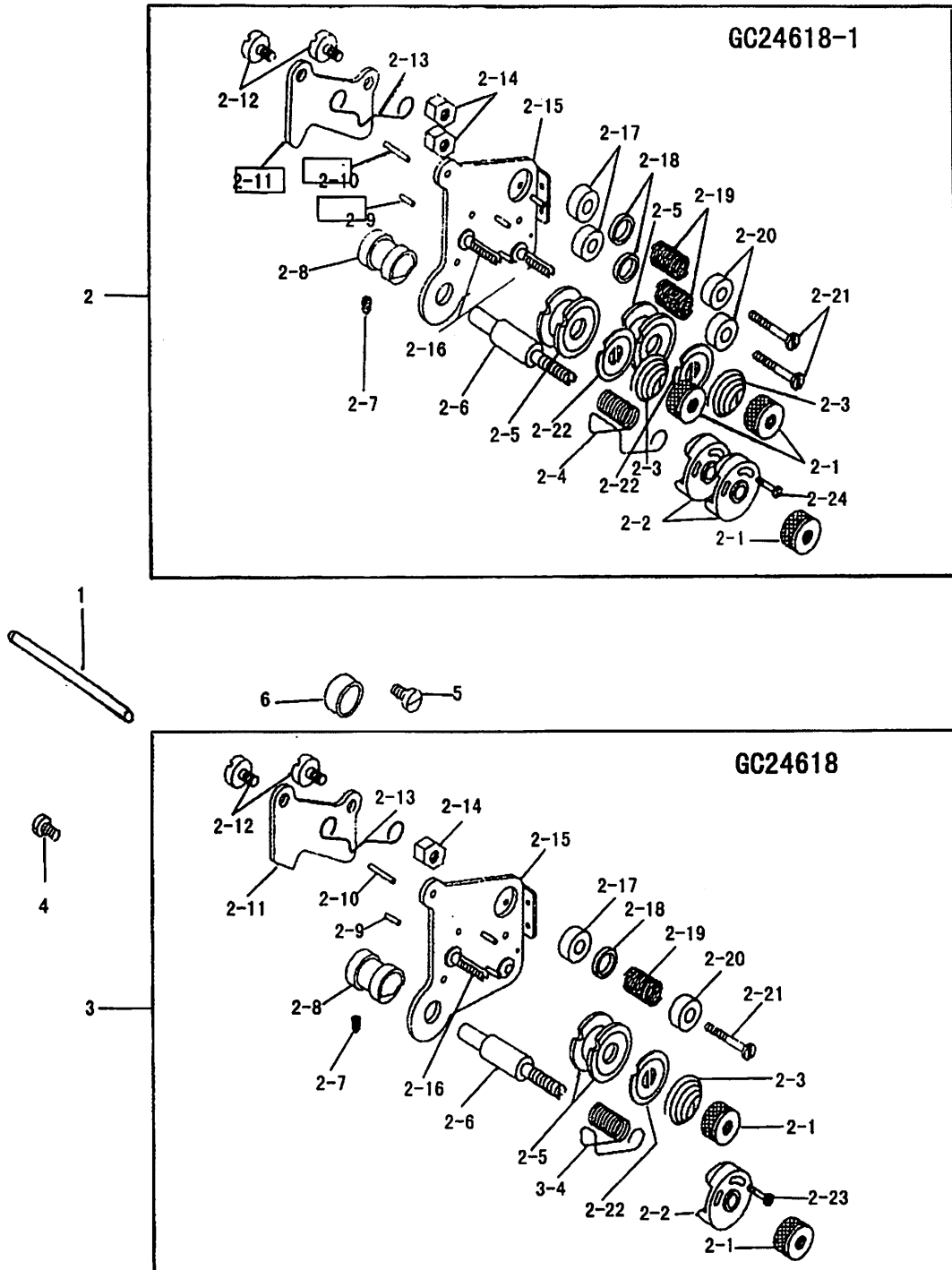

From the library of: Diamond Needle Corp

B. THREAD TENSION MECHANISM

Ref. No.	Part No.	Name of part	GC24618	GC24618-1	Remarks
1	118553	Tension releasing pin	1	1	
2	119171	Thread tension regulator assy.	0	1	(2—1 ~ 21)
2 1	119171-1	Nut	2	2	
2-2	119171-2	Thread guide assy.	1	2	
2-3	119171-3	Tension spring	1	2	
2 1	119171-4	Thread take-up spring	1	1	
2 5	119171-5	Tension disc	2	4	
2 6	119171-6	Thread tension stud	1	1	
2 7	119171-7	Screw	1	1	
2-8	119171-8	Thread tension regulationg bushing	1	1	
2-9	119171-9	Tension releasing pin	1	1	
2 10	119171-10	Tension releasing pin	1	1	
2 11	119171-11	Tension releasing plate	1	1	
2 12	119171-12	Screw	2	2	
2 13	119171-13	Tension release spring	1	1	
2 14	119171-14	Nut	1	1	
2-15	119171-15	Upper thread tension plate	1	1	
2-16	119171-16	Thread tension stud	1	2	
2-17	119171-17	Thread guide base	1	2	
2-18	119171-18	Thread guide ring	1	2	
2-19	119171-19	Thread guide spring	1	2	
2 20	119171-20	Thread guide cap	1	2	
2-21	119171-21	Screw	1	2	
2-22	119171-22	Threas tension spring retainer	1	2	
2 23	119171-23	Screw	1	0	
2 24	119171-24	Screw	0	1	
3	119766	Thread tension regulator assy.	1	0	(3—1 ~ 21)
3 4	119766 1	Thread take-up spring	1	0	
4	175096 1	Screw	1	1	
5	700412	Screw	1	1	
6	700412 1	Bushing	1	1	

C. BEARING SHAFT MECHANISM

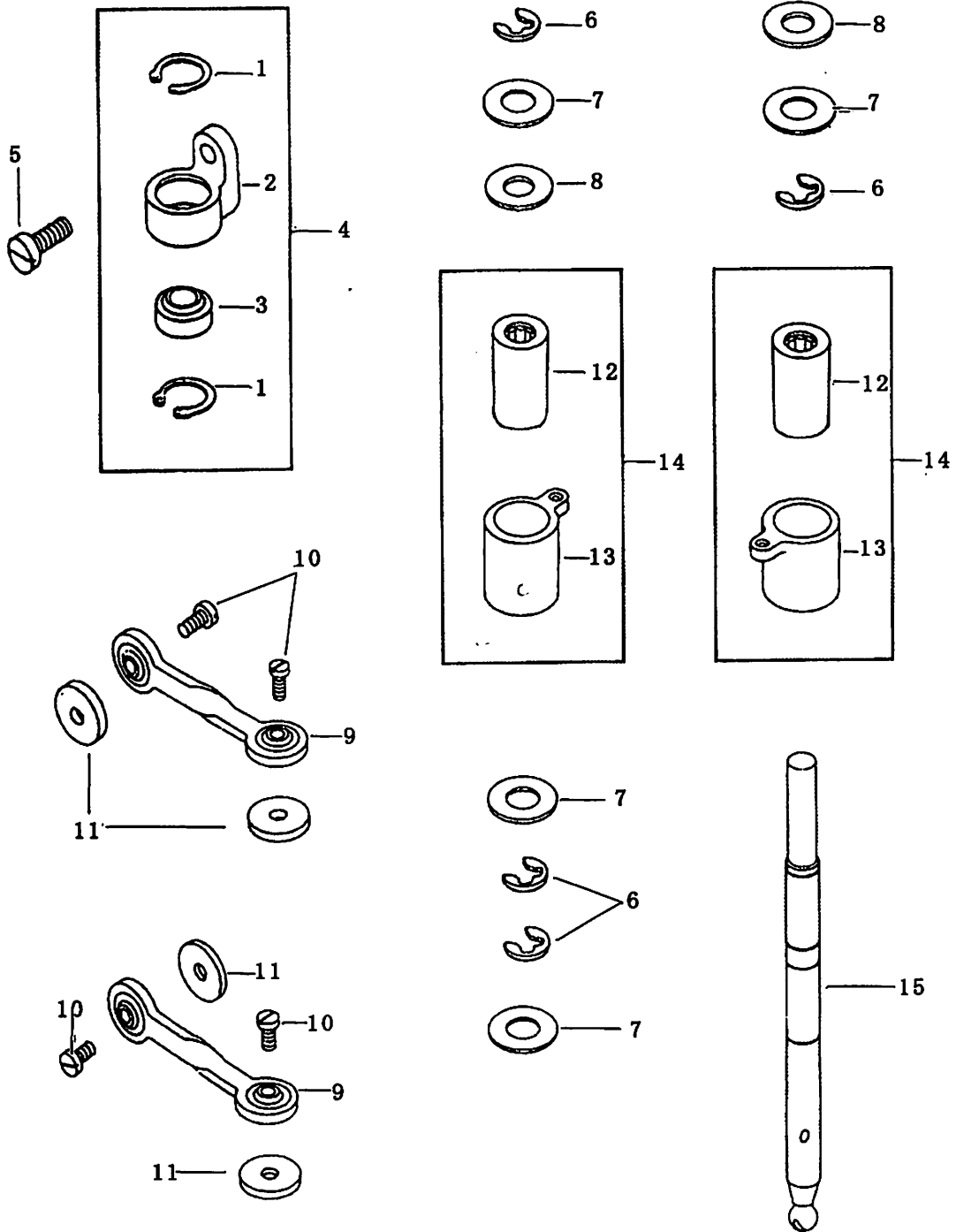

C. BEARING SHAFT MECHANISM

Ref. No.	Part No.	Name of part	GC24618	GC24618-1	Remarks
1	660290	Retaining ring	2	2	(1~3)
2	119158	Bearing bracket	1	1	
	119158-1	Bearing bracket	1	1	
3	756901	Bearing	1	1	
4	119150	Bearing assy.	1	1	
	119150-1	Bearing assy.	1	1	
5	108294	Screw	1	1	
6	640210	E-ring	4	4	
7	119159	Washer(1.0)	2	2	
7-1	119160	Washer(1.4)	2	2	
8	119886	Washer(0.1)	2	2	
8-1	119961	Washer(0.15)	2	2	
8-2	119962	Washer(0.2)	3	3	
8-3	119963	Washer(0.05)	2	2	
9	119507	Link	2	2	
10	174176	Screw	4	4	
11	119087	Oil felt	4	4	
12	061014	Needle bearing	2	2	(12, 13)
13	119505	Bearing socket	2	2	
14	119506	Bearing assy.	2	2	
15	119503	Bearing shaft	1	1	

D. ROLLER PRESSER FOOT MECHANISM

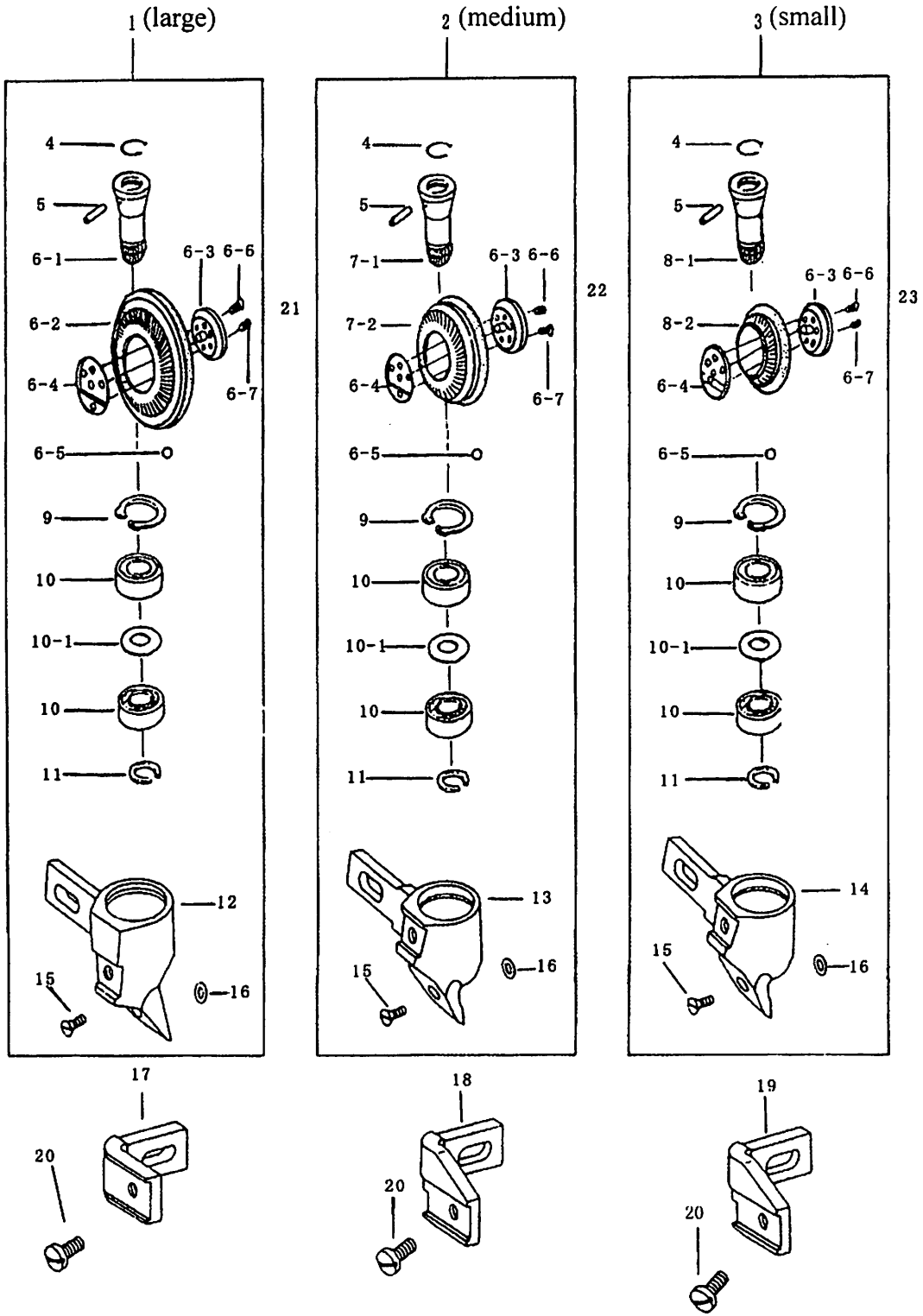

D. ROLLER PRESSER FOOT MECHANISM

Ref. No.	Part No.	Name of part	GC24618	GC24618-1	Remarks
1	119803	Roller presser assy.(large)	1	1	
2	119803-1	Roller presser assy.(medium)	1	1	
3	119802	Roller presser assy.(small)	1	1	
4	119169	C-ring	1	1	
5	033145	Pin	1	1	
6	175109	Gear	1	1	
6-1	175109-1	Driving shaft	1	1	
6-2	175109-2	Gear	1	1	
6-3	175109-3	Roller holder(front)	1	1	
6-4	175109-4	Roller holder(back)	1	1	
6-5	175109-5	Steel ball	1	1	
6-6	175109-6	Screw	1	1	
6-7	175109-7	Screw	1	1	
7	175107	Gear	1	1	
7-1	175107-1	Driving shaft	1	1	
7-2	175107-2	Gear	1	1	
7-3	175107-3	Roller holder	1	1	
8	175108	Gear	1	1	
8-1	175108-1	Driving shaft	1	1	
8-2	175108-2	Gear	1	1	
8-3	175108-3	Roller holder	1	1	
9	664290	C-ring	1	1	
10	133116	Ball bearing	1	1	
10-1	133116-1	Washer	1	2	
11	518210	C-ring	1	1	
12	119953	Roller presser bracket	1	1	
13	119943	Roller presser bracket	1	1	
14	119956	Roller presser bracket	1	1	
15	210013	Screw	1	1	
16	119191	Washer	1	1	
17	119807	Guide seat(big)	1	1	
18	119955	Guide seat(medium)	1	1	
19	119951	Guide seat(small)	1	1	
20	173174	Screw	2	1	

E. THREAD TAKE-UP MECHANISM

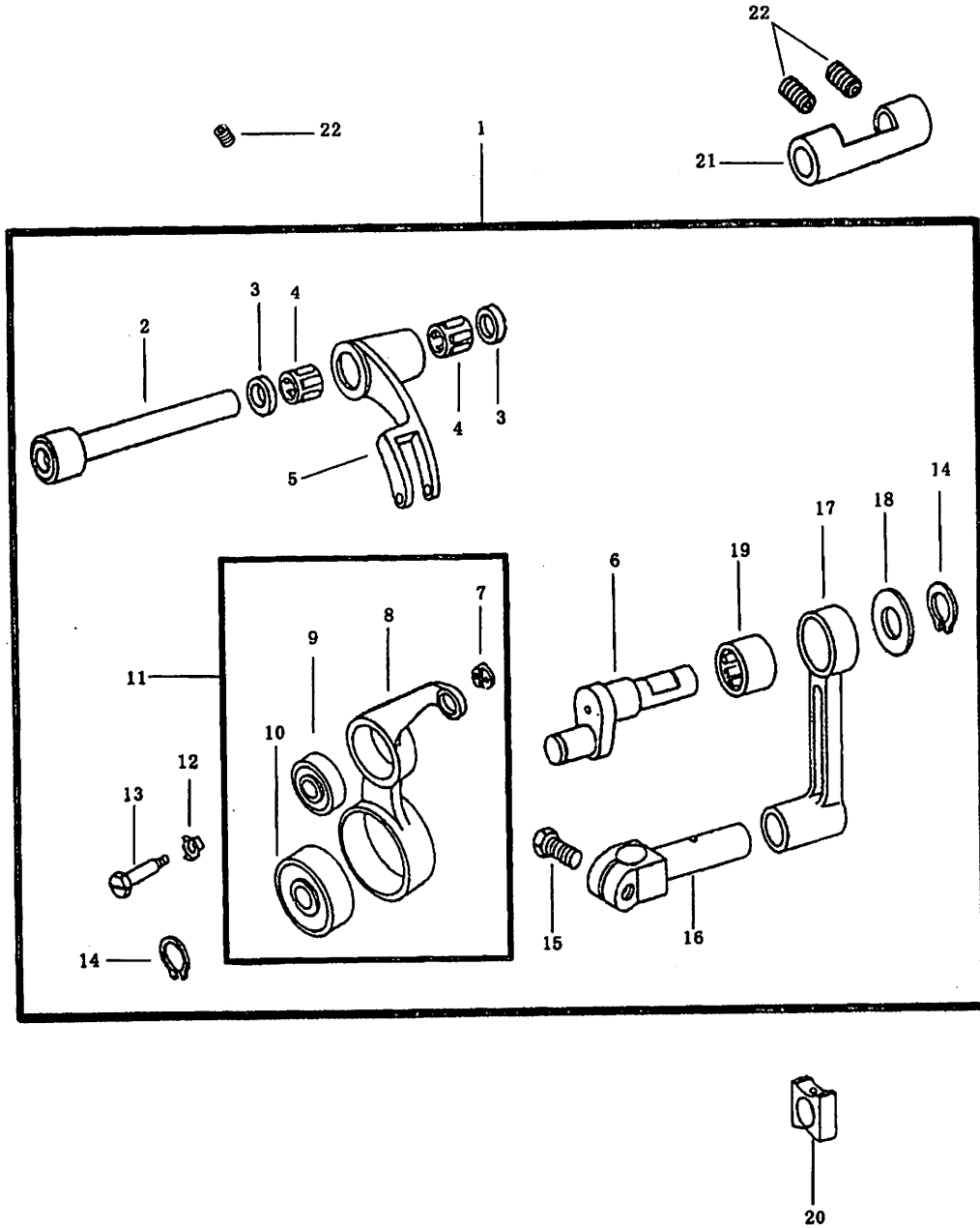

E. THREAD TAKE-UP MECHANISM

Ref. No.	Part No.	Name of part	GC24618	GC24618-1	Remarks
1	118084	Thread take-up assy.	1	1	(2~19)
2	119009	Thread take-up lever shaft	1	1	
3	168039	Thrust ring	2	2	
1	215022	Needle bearing	2	2	
5	119008	Thread take-up holder	1	1	
6	119762	Thread take-up crank	1	1	
7	119049	Thread guide	1	1	
8	119007	Thread take-up lever	1	1	
9	167569	Ball bearing	1	1	
10	167570	Ball bearing	1	1	
11	119006	Thread take-up assy.	1	1	(7~10)
12	168046	Washer	1	1	
13	168047	Bolt	1	1	
14	610210	C-ring	2	2	
15	039177	Screw	1	1	
16	119013	Needle bar connector	1	1	
17	119765	Needle bar connecting rod	1	1	
18	119763	Washer	1	1	
19	218080	Needle bearing	1	1	
20	118518	Slide block	1	1	
21	168041	Bushing	1	1	
22	314220	Screw	3	3	

F. UPPER SHAFT MECHANISM

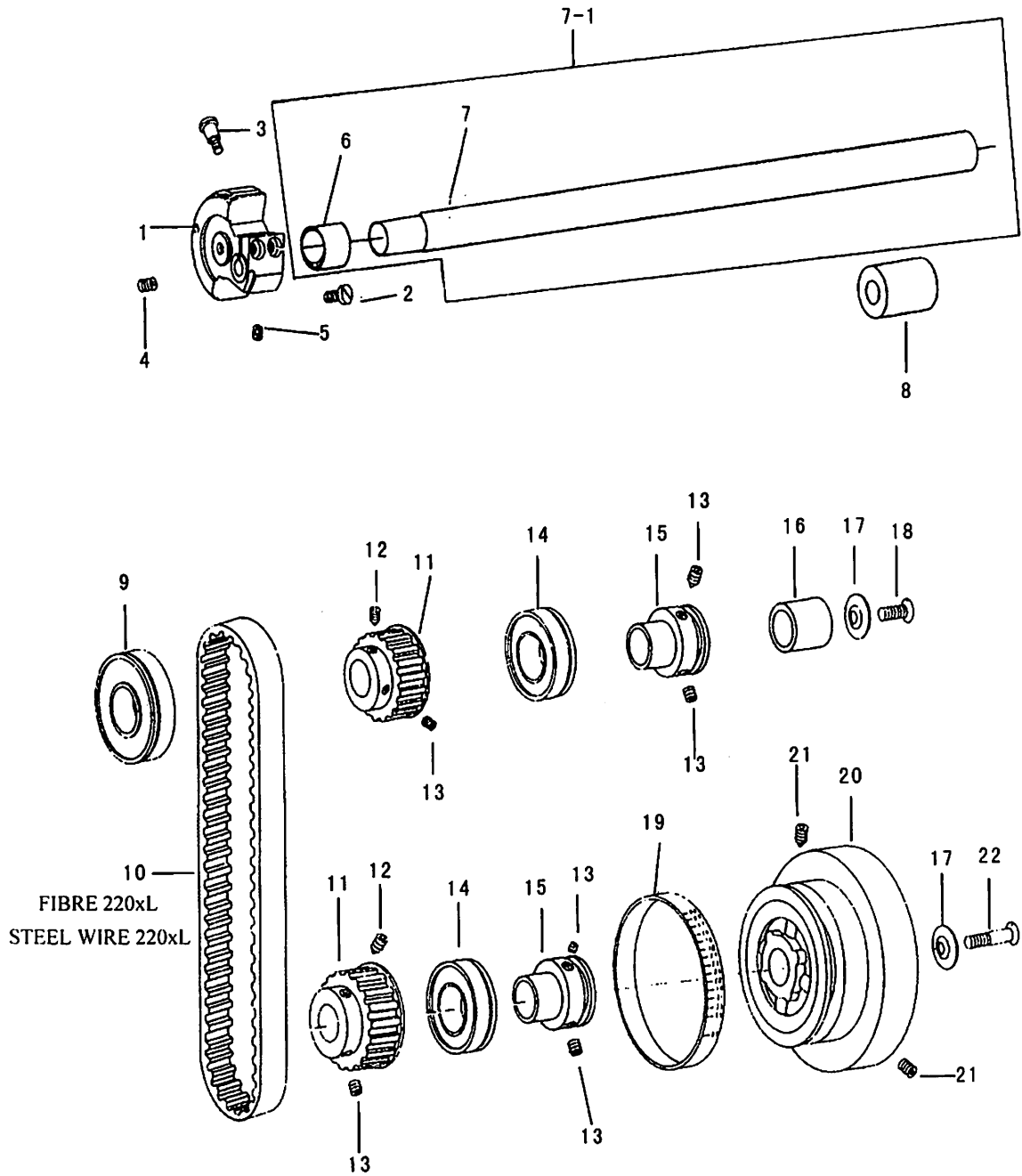

F. UPPER SHAFT MECHANISM

Ref. No.	Part No.	Name of part	GC24618	GC24618-1	Remarks
1	119702-2	Cam	1	1	
2	130224	Screw	2	2	
3	119702-3	Screw	1	1	
4	119702-4	Screw	1	1	
5	700510	Screw	1	1	
6	119702-5	Bushing	1	1	
7	119702-1	Upper shaft	1	1	
7-1	119702A	Upper shaft assy.	1	1	
8	119702-6	Bushing	0	1	
9	018643	Ball bearing	1	1	
10	069160	Timing belt	1	1	
10-1	069160-1	Timing belt	1	1	
11	119707	Timing belt wheel	2	2	
12	335902	Screw	2	2	
13	335902-1	Screw	6	6	
14	016153	Ball bearing	2	2	
15	119705	Arm shaft bushing	2	2	
16	069746	Bushing	1	1	
17	168480	Washer	2	2	
18	210265	Screw	1	1	
19	175048	Stitch ring	1	1	
20	170913	Balance wheel	1	1	
21	341902	Screw	2	2	
22	210287	Screw	1	1	

G. UPPER SIDE SHAFT MECHNISM

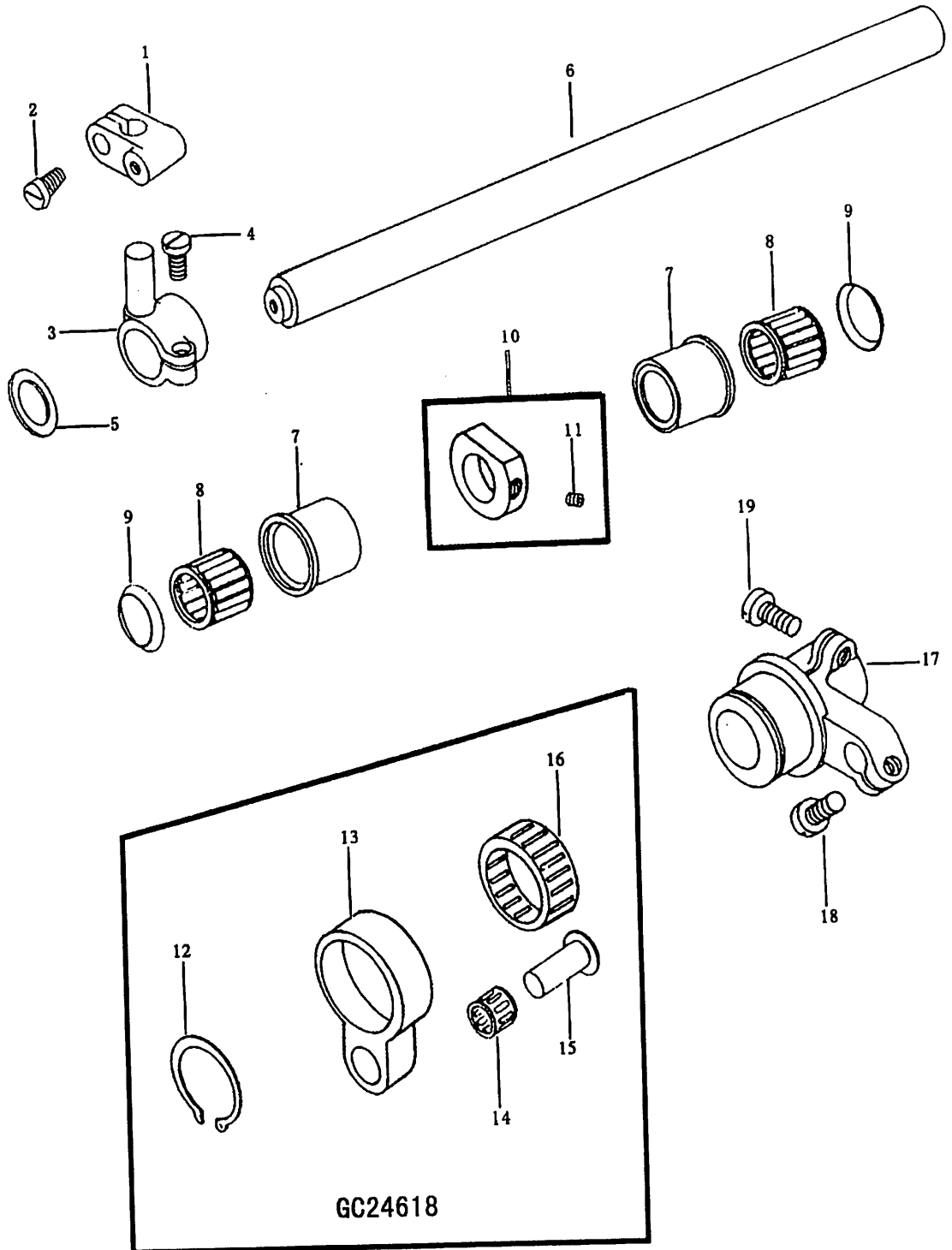

G. UPPER SIDE SHAFT MECHNISM

Ref. No.	Part No.	Name of part	GC24618	GC24618-1	Remarks
1	119164	Adapter	1	1	
2	108177	Screw	1	1	
3	119163	connector	1	1	
4	108225	Screw	1	1	
5	119085	Washer	1	1	
6	119511	Upper side shaft	1	1	
7	118600	Bushing	2	2	
8	215124	Needle Bearing	2	2	
9	133283	Washer	2	2	
10	118504	collar	1	1	
11	118503	Screw	1	1	(11)
12	610370	C-ring	1	0	
13	119042-2	Link	1	0	
14	215028	Needle Bearing	1	0	
15	175150	Pin	1	0	
16	242810	Needle Bearing	1	0	
17	119042	Eccentric cam	1	1	
18	108225-2	Screw	1	1	
19	130224	Screw	1	1	

H. NEEDLE BAR MECHANISM

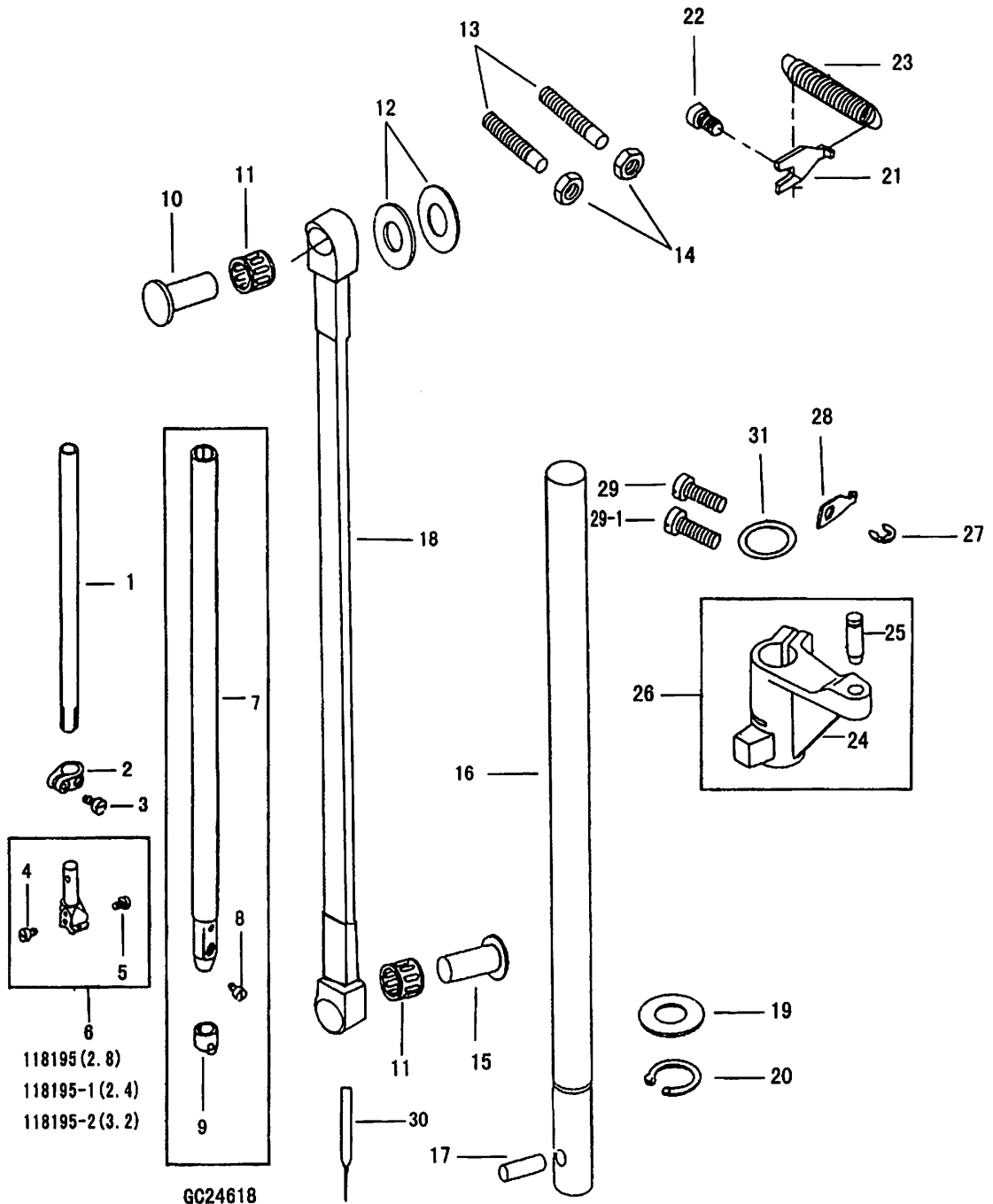

H. NEEDLE BAR MECHANISM

Ref. No.	Part No.	Name of part	GC24618	GC24618-1	Remarks
1	118197	Needle bar	0	1	
2	118196	Needle bar clamp	0	1	
3	108174-1	Screw	0	1	
4	700868	Screw	0	1	
5	700868-1	Screw	0	1	
6	118195	Needle holder(2.8)	0	1	(4, 5)
	118195-1	Needle holder(2.4)	0	1	(4, 5)
	118195-2	Needle holder(3.2)	0	1	
7	175096	Needle bar	1	0	
8	174173	Screw	1	0	
9	175096-2	Needle guide	1	0	
10	175150	Pin(short)	1	1	
11	215028	Needle bearing	2	2	
12	169137	Washer	2	2	
13	305305	Screw	2	2	
14	024191	Nut	2	2	
15	118612	Pin(long)	1	1	
16	119718	Presser lifting shaft	1	1	
17	030310	Pin	1	1	
18	119046	Connecting Rod	1	1	
19	119525-2	Washer	1	1	
20	119718-2	C-ring	1	1	
21	118858	Fitting plate	1	1	
22	108285	Screw	1	1	
23	118857	Spring	1	1	
24	118543	Crank	1	1	
25	118544	Pin	1	1	(24, 25)
26	118543A	Crank assy.	1	1	
27	640150	E-ring	1	1	
28	020490	Spring plate	1	1	
29	130224	Screw	2	2	
29.1	130224-1	Screw	1	1	
30	134356	Needle	1	1	
31	118545	Washer	1	1	

I. NEEDLE BAR FEEDING MECHANISM

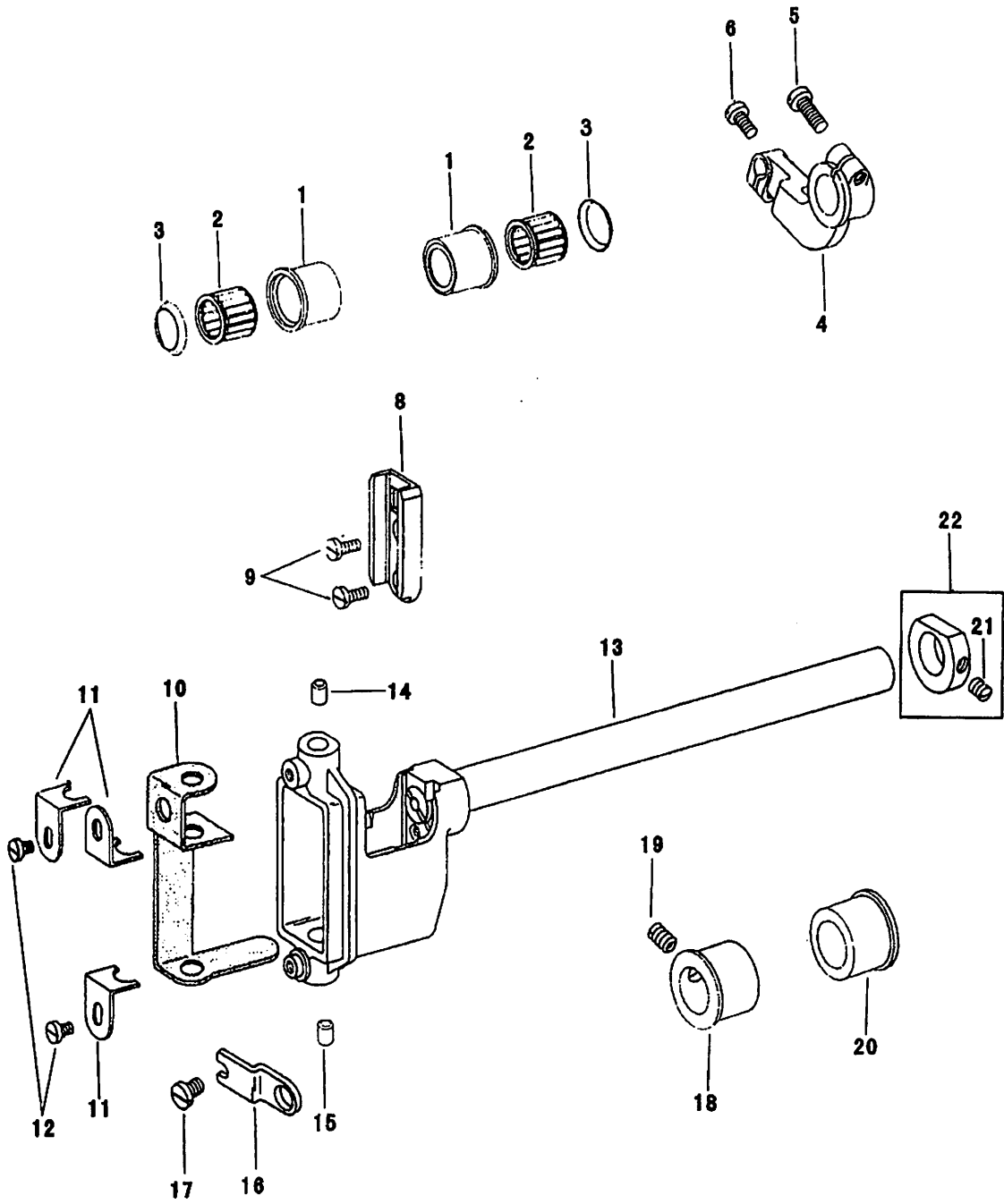

I. NEEDLE BAR FEEDING MECHANISM

Ref. No.	Part No.	Name of part	GC24618	GC24618-1	Remarks
1	118600	Bushing	2	0	
2	215124	Needle bearing	2	0	
3	133283	Washer	4	0	
4	118610	Crank	1	0	
5	108285-1	Screw	1	0	
6	130224	Screw	1	0	
8	118594	Guide trough	1	1	
9	100355	Screw	2	2	
10	119014	Bracket	1	1	
11	119015	Fitting plate	3	3	
12	706169	Screw	2	2	
13	119940	Needle bar hold	1	1	
14	119940-5	Needle bar bushing(upper)	1	1	
15	119940-4	Needle bar bushing(lower)	1	1	
16	118521	Fitting plate	0	1	
17	108219	Screw	0	1	
18	118520	Bushing	0	1	
19	314286	Screw	0	1	
20	118520-1	Bushing	0	1	
21	118503	Screw	1	1	
22	118504	Collar assy.	1	1	(21)

J. PRESSER BAR MECHANISM

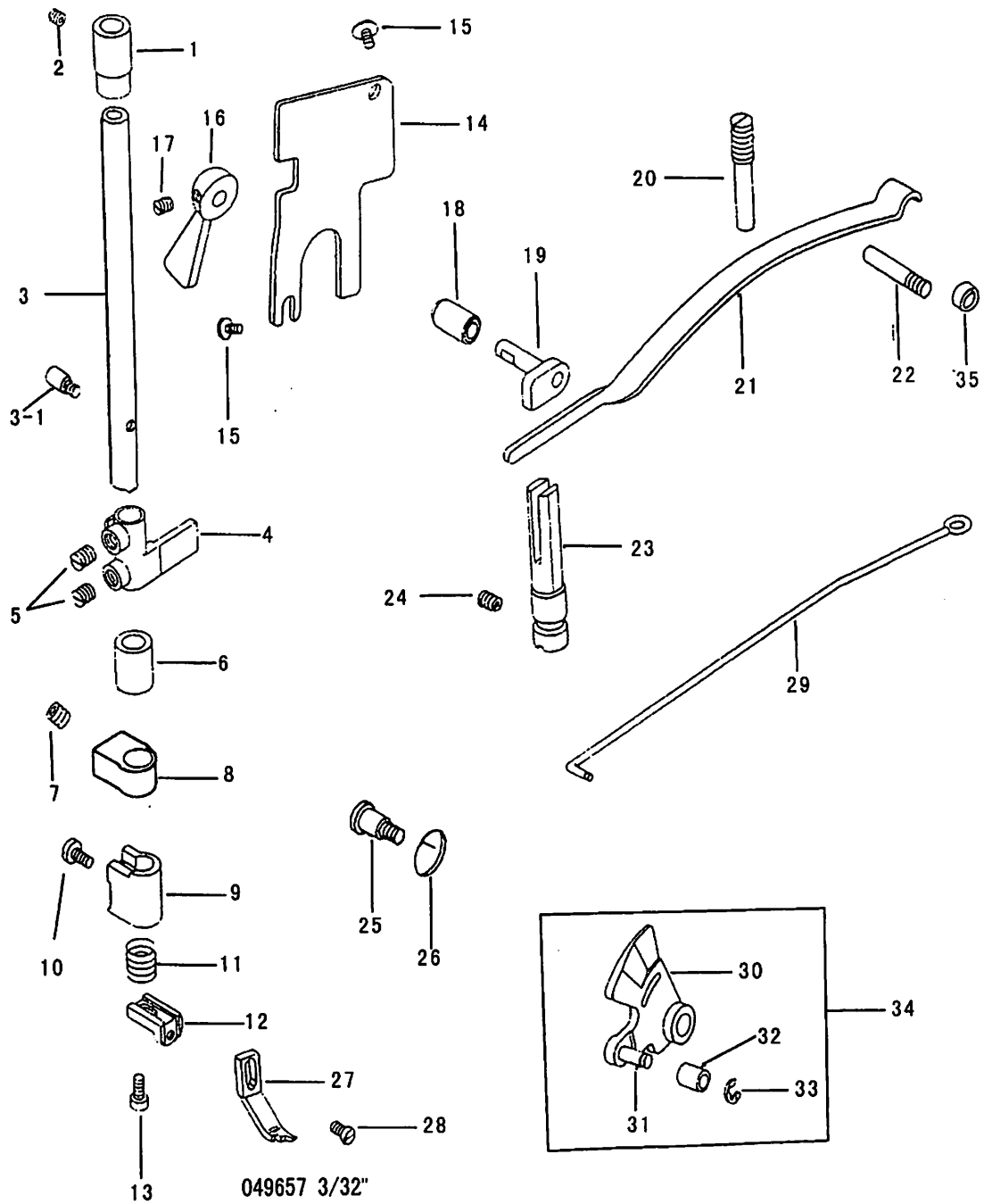

J. PRESSER BAR MECHANISM

Ref. No.	Part No.	Name of part	GC24618	GC24618-1	Remarks
1	119019	Presser bar bushing(upper)	1	1	
2	700785	Screw	1	1	
3	119018	Presser bar	1	1	
3-1	119018-1	Pin	1	1	
4	118530	Presser bar holder	1	1	
5	700510	Screw	2	2	
6	119019-1	Presser bar bushing(lower)	1	1	
7	700510-1	Screw	1	1	
8	119165-1	Presser bar retainer(upper)	1	1	
9	119165	Presser bar retainer(lower)	1	1	
10	173174	Screw	1	1	
11	025874	Spring	1	1	
12	054876	Bracket	1	1	
13	130173	Screw	1	1	
14	175135	Cover plate	1	1	
15	700335	Screw	2	2	
16	069079	Presser foot lifter	1	1	
17	317950	Screw	1	1	
18	119004	Bushing	1	1	
19	118577	Foot lifter shaft	1	1	
20	100331	Screw	1	1	
21	118535	Spring plate	1	1	
22	343901	Screw	1	1	
23	118105	Guide stud	1	1	
24	314286	Screw	1	1	
25	700017	Screw	1	1	
26	119016	Spring	1	1	
27	049657	Presser foot	0	1	
	049657-1	Presser foot	0	1	
28	108171	Screw	0	1	
29	118542	Knee lifter connecting rod	1	1	
30	118536	lifting lever	1	1	
31	118536-1	Pin	1	1	
32	118539	Bushing	1	1	
33	640150	E-ring	1	1	
34	118536A	Lifting lever assy.	1	1	(30~33)
35	343902	Bushing	1	1	

K. TIMING BELT DRIVING MECHANISM

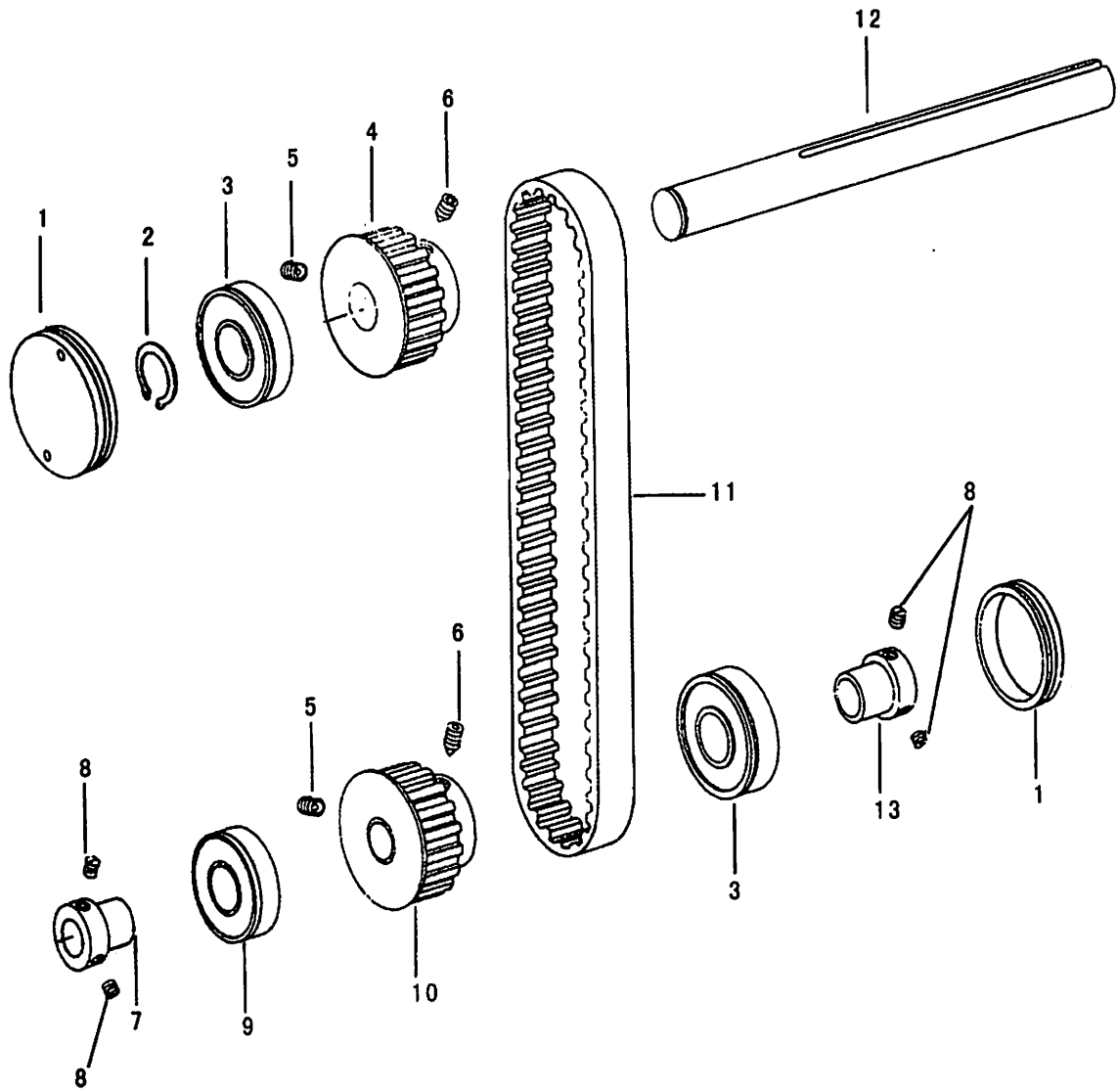

K. TIMING BELT DRIVING MECHANISM

Ref. No.	Part No.	Name of part	GC24618	GC24618-1	Remarks
1	119097	Cover	2	2	
2	610300	C-ring	1	1	
3	018624	Ball bearing	2	2	
4	119707	Timing belt wheel	1	1	
5	335902 1	Screw	2	2	
6	335902	Screw	2	2	
7	119121	Collar(left)	1	1	
8	700689	Screw	4	4	
9	018613	Ball bearing	1	1	
10	119708	Timing belt wheel	1	1	
11	069161	Timing belt	1	1	
	069161-1	Timing belt	1	1	
12	119706	Shaft	1	1	
13	118726	Collar(right)	1	1	

From the library of: Diamond Needle Corp

L. STITCH REGULATOR MECHANISM

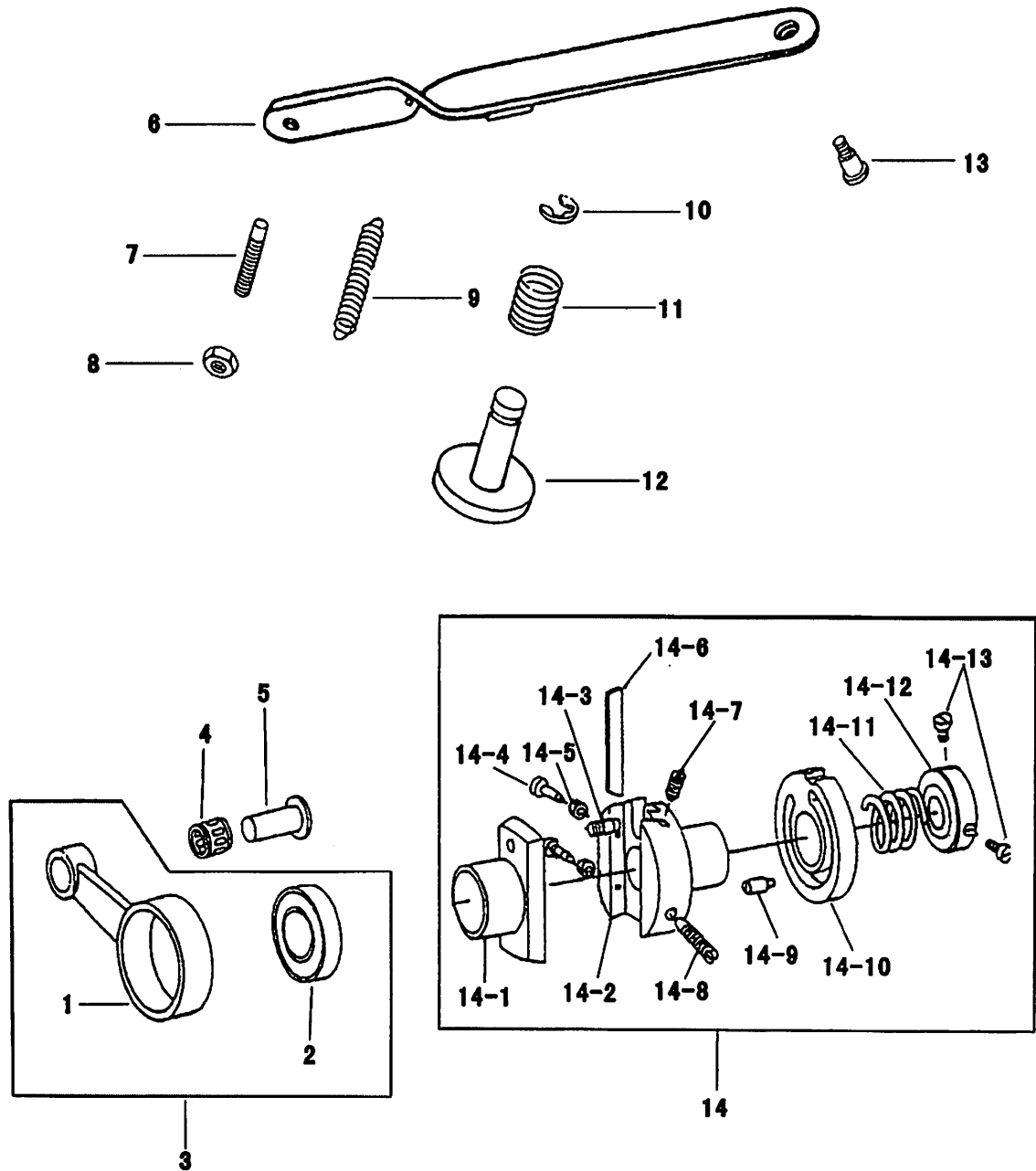

L. STITCH REGULATOR MECHANISM

Ref. No.	Part No.	Name of part	GC24618	GC24618-1	Remarks
1	175038	Connecting rod	1	1	(1, 2)
2	6096	Ball bearing	1	1	
3	175038A	Connecting rod assy.	1	1	
4	215028	Needle bearing	1	1	
5	118612	Pin	1	1	
6	165356	Stitch adjusting plate	1	1	
7	165356-1	Screw	1	1	
8	165356-8	Nut	1	1	
9	165356-5	Spring	1	1	
10	165356-7	E-ring	1	1	
11	165356-6	Spring	1	1	
12	165356-2	Pin	1	1	
13	165356-3	Screw	1	1	
14	175029	Cam assy.	1	1	
14-1	175029-1	Stitch regulating slide	1	1	
14-2	175029-2	Stitch Regulating block	1	1	
14-3	175029-3	Stud	1	1	
14-4	175029-4	Screw	1	1	
14-5	175029-5	Nut	1	1	
14-6	175029-6	Presser plate	1	1	
14-7	175029-7	Screw	1	1	
14-8	175029-8	Screw	1	1	
14-9	175029-9	Stud	1	1	
14-10	175029-10	Eccentric cam	1	1	
14-11	175029-11	Spring	1	1	
14-12	175029-12	Collar	1	1	
14-13	175029-13	Screw	2	2	

M. FEED MECHANISM

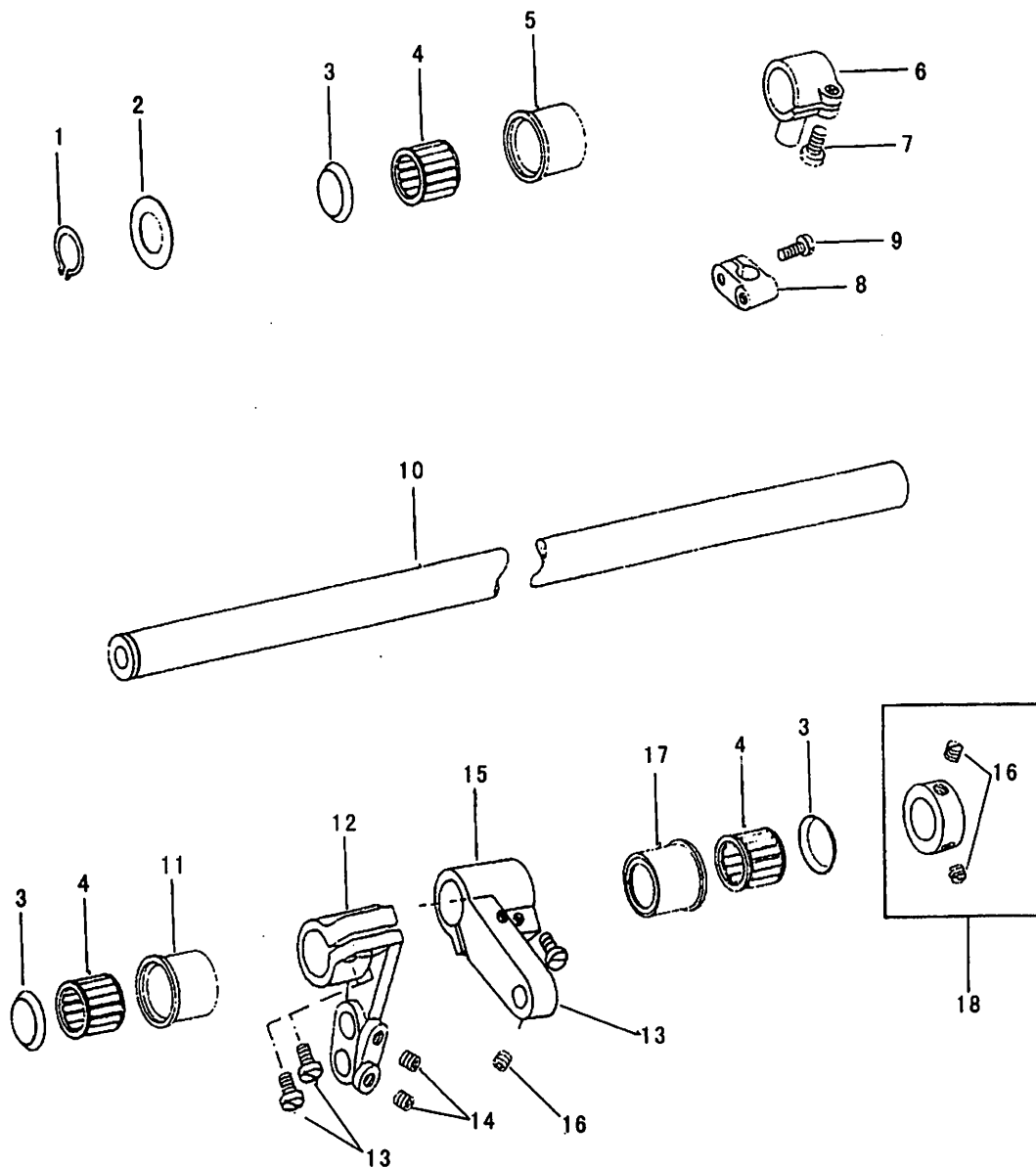

From the library of: Diamond Needle Corp

M. FEED MECHANISM

Ref. No.	Part No.	Name of part	GC24618	GC24618-1	Remarks
1	610280	C-ring	1	1	
2	119085	Washer	1	1	
3	133283	Cap	6	6	
4	215124	Needle bearing	3	3	
5	118600	Bushing	1	1	
6	119163	Connector	1	1	
7	108225	Screw	1	1	
8	119164	Connector	1	1	
9	108177	Screw	1	1	
10	119084	Feed rock shaft	1	1	
11	118601	Bushing	1	1	
12	119521	Crank	1	1	
13	130224	Screw	3	3	
14	335902-1	Screw	2	2	
15	119521-1	Crank	1	1	
16	700689	Screw	3	3	
17	118603	Bushing	1	1	
18	119893	Collar	1	1	(16)

N. CLUTCH MECHANISM

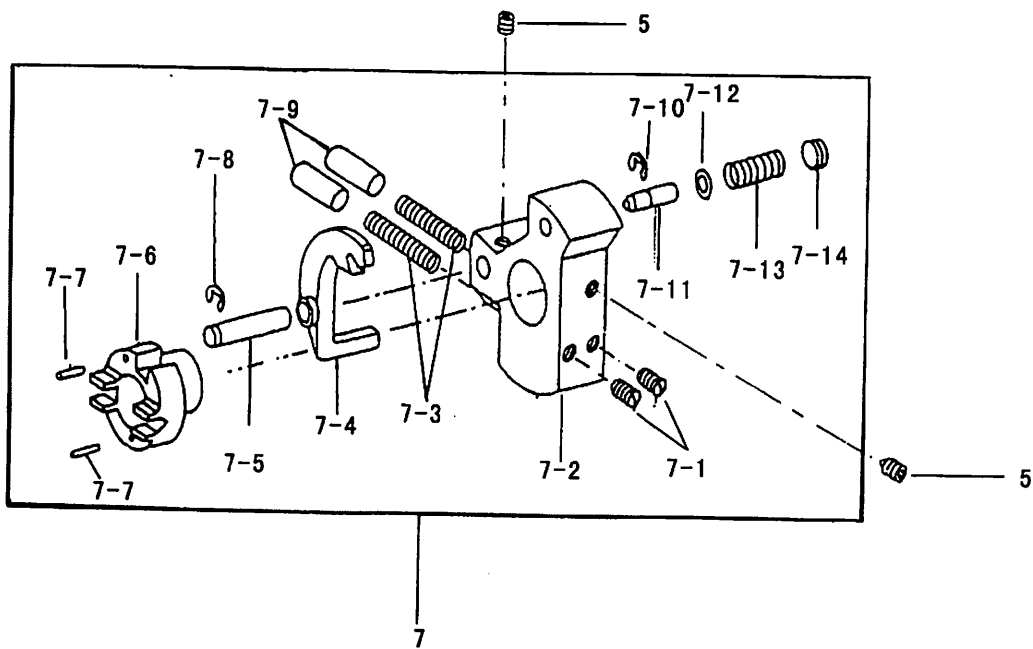
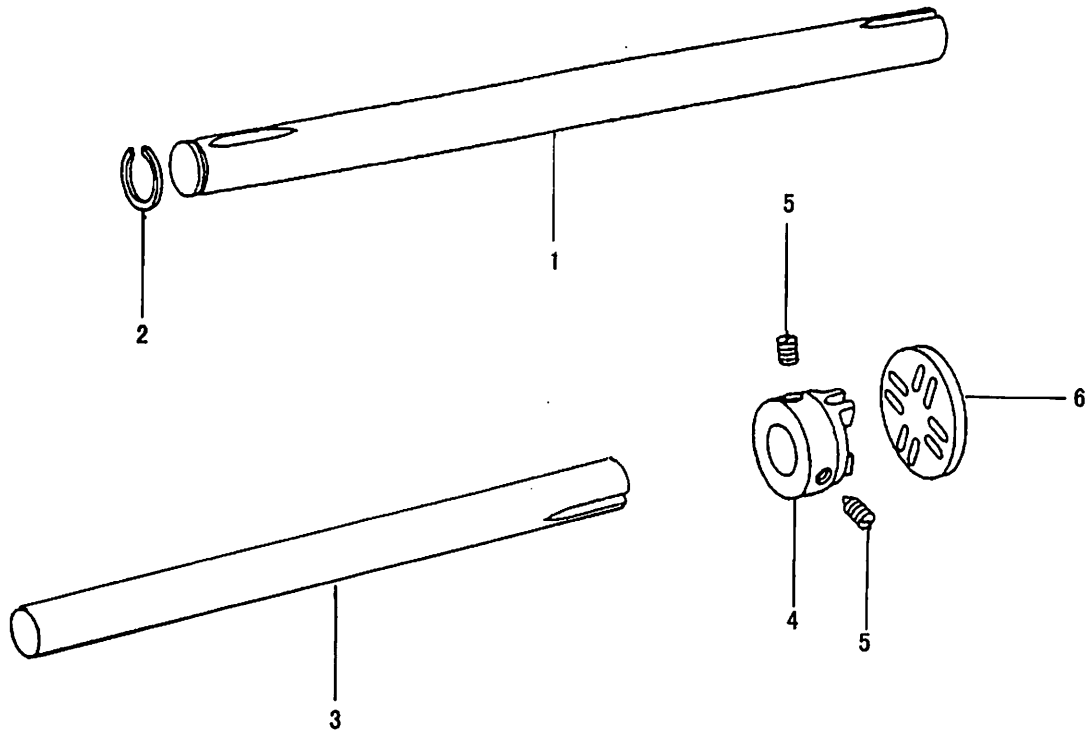

N. CLUTCH MECHANISM

Ref. No.	Part No.	Name of part	GC24618	GC24618-1	Remarks
1	175025	Shaft	1	1	(7-1~7-14)
2	518250	C-ring	1	1	
3	119711	Shaft(short)	1	1	
4	175019	Shaft coupler(left)	1	1	
5	341901	Screw	4	4	
6	133109	Connecting plate	1	1	
7	119081A	Safty clutch assy.	1	1	
7-1	700510	Screw	2	2	
7-2	172263	Safty clutch block	1	1	
7-3	013153	Spring	2	2	
7-4	173261	Latch	1	1	
7-5	009408	Hinge stud	1	1	
7-6	173264	Shaft coupler(right)	1	1	
7-7	065052	Pin	2	2	
7-8	640150	E-ring	1	1	
7-9	175023	Stud	2	2	
7-10	640130	E-ring	1	1	
7-11	013076	Pin	1	1	
7-12	009037	Washer	1	1	
7-13	009343	Spring	1	1	
7-14	175126	Set screw	1	1	

O. CENTRAL POST BED MECHANISM FOR SINGLE NEEDLE

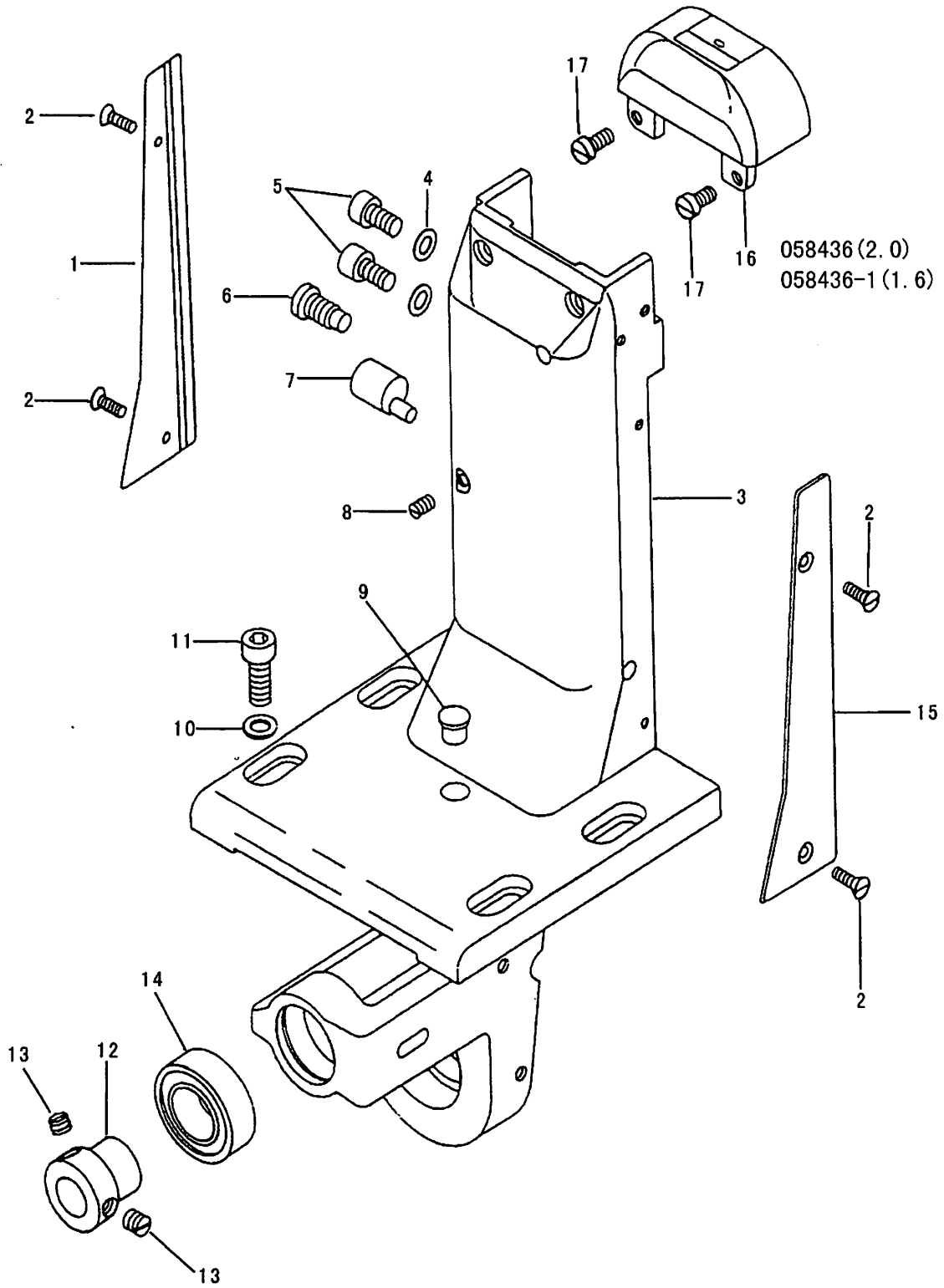

O. CENTRAL POST BED MECHANISM FOR SINGLE NEEDLE

Ref. No.	Part No.	Name of part	GC24618	GC24618-1	Remarks
1	119145	Cover plate	1	0	
2	250084	Screw	4	0	
3	119721	Post	1	0	
4	119144	Washer	2	0	
5	130224	Screw	2	0	
6	182451	Screw	1	0	
7	119725	Stud pin	1	0	
8	317170	Screw	1	0	
9	168351	Plug	1	0	
10	305174	Washer	4	0	
11	135292	Screw	4	0	
12	119121	Collar	1	0	
13	700689	Screw	2	0	
14	016120	Ball bearing	1	0	
15	305144	Cover plate	1	0	
16	058436	Needle plate(2.0)	1	0	
	058436-1	Needle plate(1.6)	1	0	
17	210168	Screw	2	0	

P. GEAR DRIVING MECHANISM FOR SINGLE NEEDLE

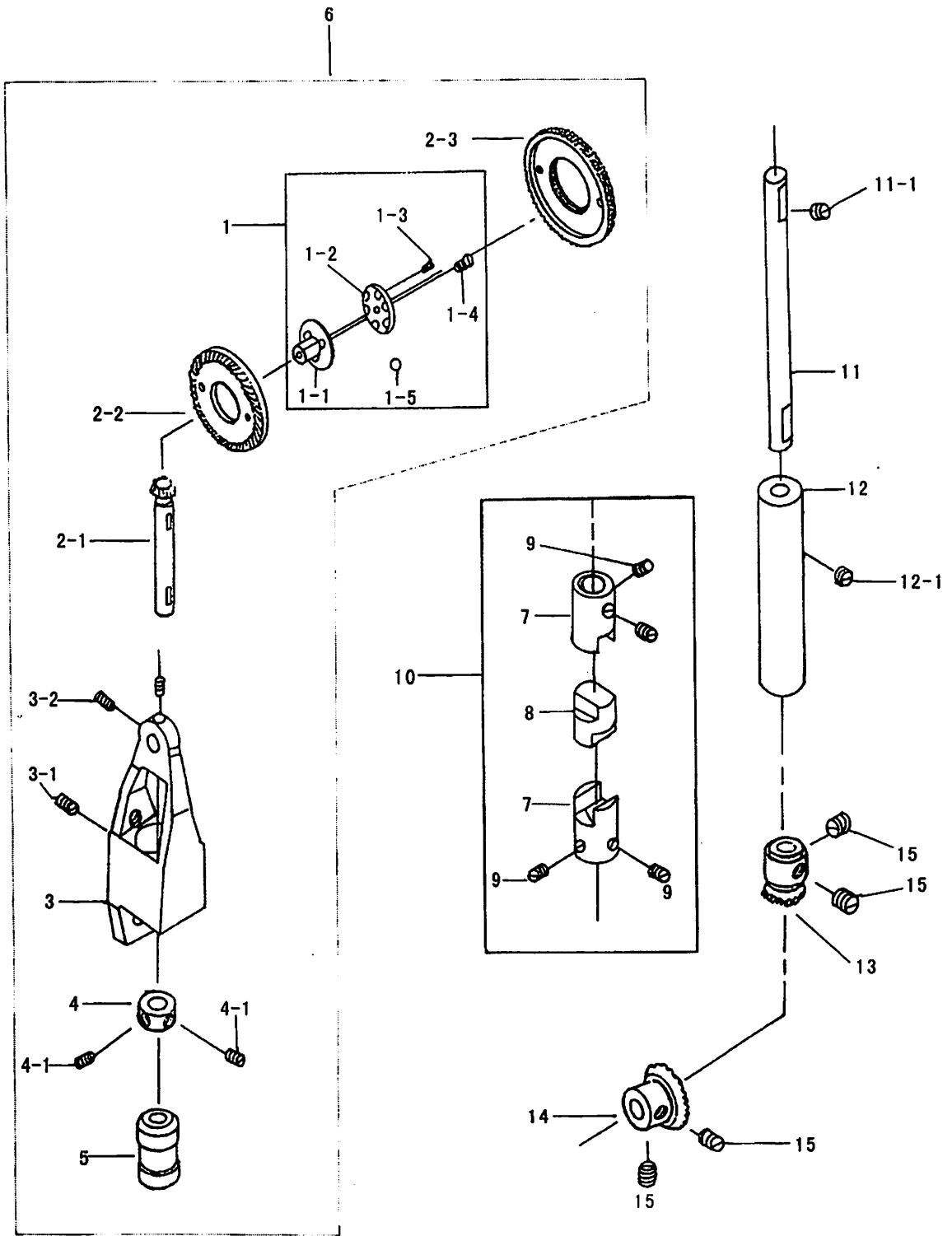

P. GEAR DRIVING MECHANISM FOR SINGLE NEEDLE

Ref. No.	Part No.	Name of part	GC24618	GC24618-1	Remarks
1	119795	Gear shaft assy.	1	0	
1-1	119795-1	Gear shaft(upper)	1	0	
1-2	119795-2	Gear shaft(lower)	1	0	
1-3	119795-3	Screw	1	0	
1-4	119795-4	Screw	1	0	
1-5	119795-5	Steel ball	24	0	
2	119737	Bevel gear assy.	1	0	
2-1	119737-1	Bevel gear shaft	1	0	
2-2	119737-2	Bevel gear	1	0	
2-3	119737-3	Feed wheel	1	0	
3	119723	Gear bracket	1	0	
3-1	119723-1	Screw	1	0	
3-2	119723-2	Screw	2	0	
4	119670	Collar	1	0	
4-1	119670-1	Screw	2	0	(1~5)
5	119724	Bushing	1	0	
6	119723A	Bevel gear driving assy.	1	0	
7	119535	shaft coupler	2	0	
8	119534	Joint	1	0	
9	119535-1	Screw	4	0	(7~9)
10	119535A	Shaft coupler assy.	1	0	
11	119532	Central post shaft	1	0	
11-1	119535-1	Screw	2	0	
12	119533	Bushing	1	0	
13	5045	Bevel gear(small)	1	0	
14	5046	Bevel gear(medium)	1	0	
15	700689	Screw	4	0	(13~15)
16	175113	Central bevel gear assy.	1	0	

Q. LEFT AND MIDDLE POST BED MECHANISM FOR TWO NEEDLE

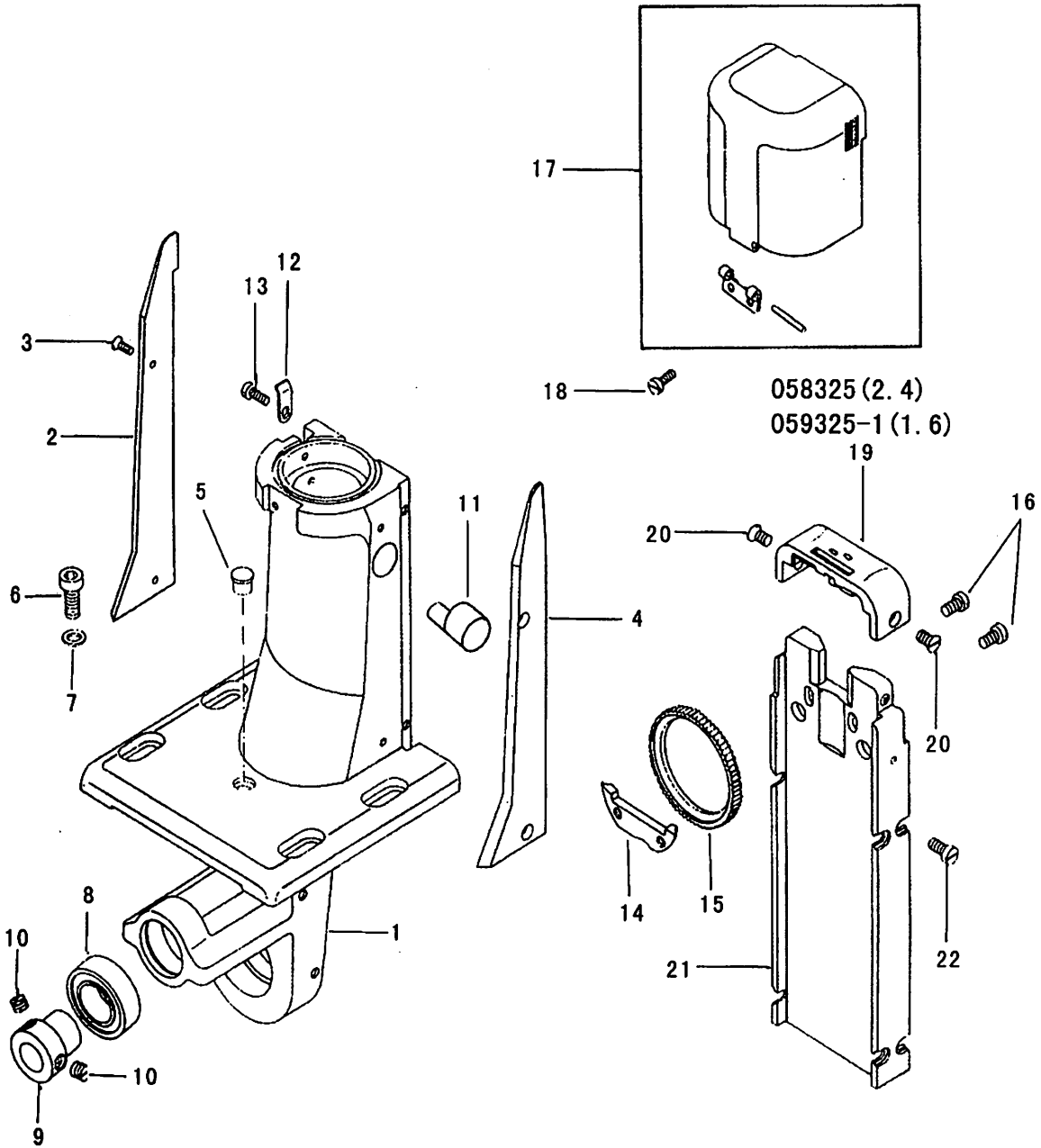

Q. LEFT AND MIDDLE POST BED MECHANISM FOR TWO NEEDLE

Ref. No.	Part No.	Name of part	GC24618	GC24618-1	Remarks
1	119976	Side bracket(left)	0	1	
2	119499	Cover plate	0	1	
3	250084	Screw	0	4	
4	119695	Cover plate	0	1	
5	168351	Plug	0	1	
6	135292	Screw	0	4	
7	305174	Washer	0	4	
8	016120	Ball bearing	0	1	
9	119121	Collar	0	1	
10	700689	Screw	0	2	
11	175318	Stud	0	1	
12	119143	Spring plate	0	1	
13	108093	Screw	0	1	
14	119138	Fitting plate	0	1	
15	119136	Feed wheel	0	1	
16	108174-1	Screw	0	2	
17	119140	Post cap assy.	0	2	
18	108093	Screw	0	2	
19	058325	Needle plate(2.4)	0	1	
	058325-1	Needle plate(1.6)	0	1	
	058325-2	Needle plate(2.0)	0	1	
20	100296	Screw	0	2	
21	119296	Central support	0	1	
22	108174-1	Screw	0	8	

R. LEFT POST MECHANISM FOR SINGLE NEEDLE

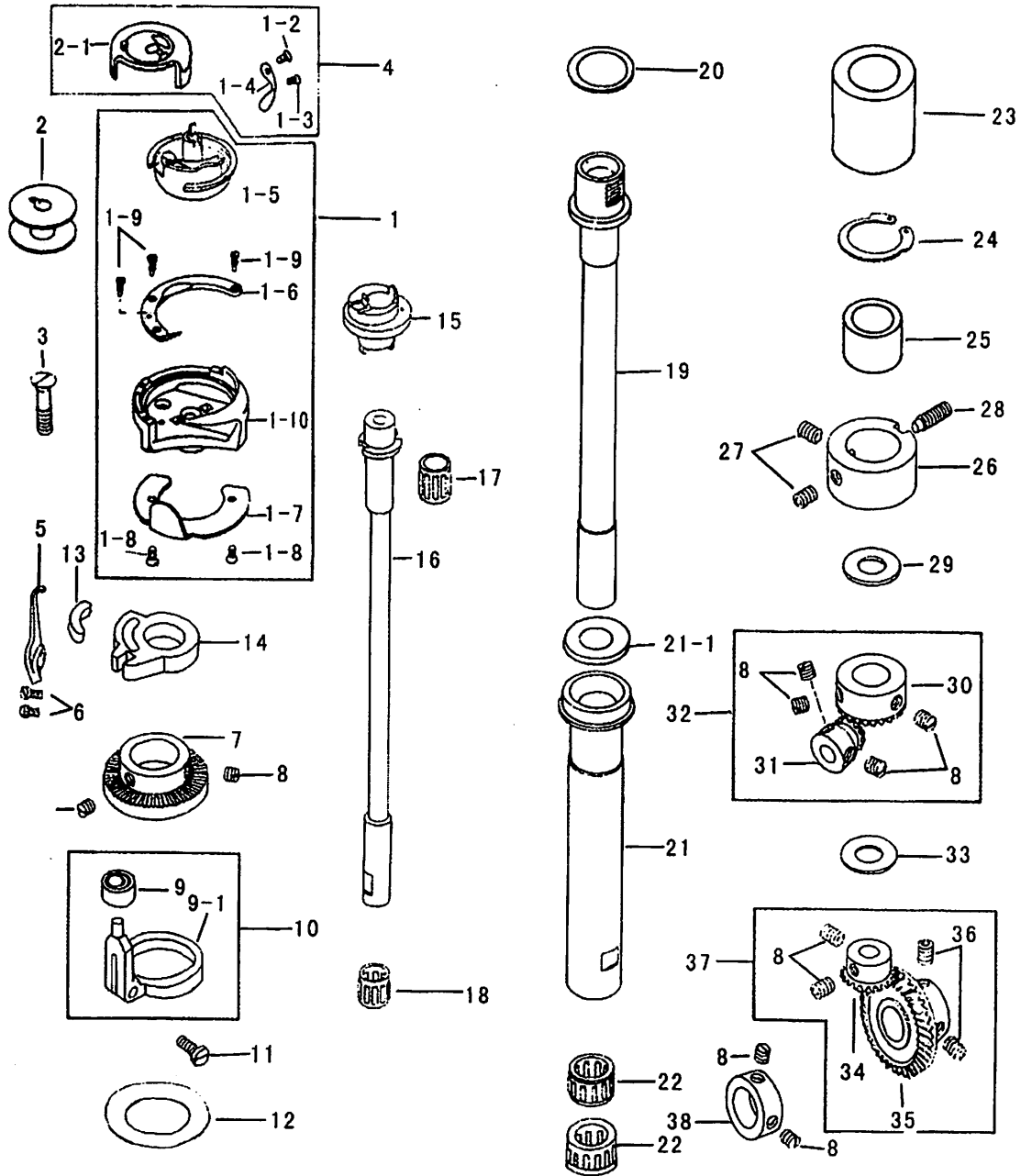

R. LEFT POST MECHANISM FOR SINGLE NEEDLE

Ref. No.	Part No.	Name of part	GC24618	GC24618-1	Remarks
1	119716A	Rotating hook assy.	0	1	1-1-10
1-2	000390	Screw	0		
1-3	000928	Screw	0	1	
1-4	010166	Spring	0	1	
1-5	119487	Bobbin case	0	1	
1-6	175136	Hook gib	0	1	
1-7	119377	Needle guard	0	1	
1-8	000219	Screw	0	2	
1-9	100529	Screw	0	3	
1-10	119376	Rotating hook	0	1	
2	010079	Bobbin	0	1	
2-1	0100158	Bobbin case	0	1	
3	100205	Screw	0	2	
4	119716	Bobbin case assy.	0	1	
5	119129	Rotating hook opener	0	1	
6	108093	Screw	0	2	
7	119494	Gear	0	1	
8	700689	Screw	0	8	
9	694ZZ	Ball bearing	0	1	
9-1	119106-1	Holder	0	1	
10	119106	Opener bracket assy.	0	1	(9)
11	108177	Screw	0	1	
12	119105	Washer	0	1	
13	119128	Oil felt	0	1	
14	119127	Hook opener bracket	0	1	
15	119525-1	Hook socket	0	1	
16	119525	Hook shaft	0	1	
17	215031	Needle bearing	0	1	
18	215028	Needle bearing	0	1	
19	119108	Bushing	0	1	
20	125010	Washer	0	1	
21	119104	Out bushing	0	1	
21-1	119108-1	Washer	0	1	
22	141710	Needle bearing	0	2	
23	119979	Bushing	0	1	
24	664390	C-ring	0	1	
25	175138	Bushing	0	1	
26	119107	Collar	0	1	
27	341901	Screw	0	2	
28	119950	Screw	0	1	
29	119947	Washer(0.2)	0	1	
29-1	119957	Washer(0.1)	0	2	
29-2	119958	Washer(0.15)	0	1	

R. LEFT POST MECHANISM FOR SINGLE NEEDLE

Ref. No.	Part No.	Name of part	GC24618	GC24618-1	Remarks
29-3	119959	Washer(0.5)	0	1	
29-4	119960	Washer(2.0)	0	1	
30	119109-1	Bevel gear(large)	0	1	
31	119109-2	Bevel gear(small)	0	1	
32	119108	Bevel gear assy.	0	1	(8, 30, 31)
33	125010	Washer(0.5)	0	2	
33-1	122718	Washer(0.1)	0	1	
33-2	125008	Washer(0.15)	0	1	
33-3	125009	Washer(0.2)	0	1	
34	119133-1	Bevel gear(large)	0	1	
35	119133-2	Bevel gear(small)	0	1	
36	341901-1	Screw	0	2	
37	119133	Bevel gear assy.	0	1	(8, 34-36)
38	123778	Collar	0	1	

S. RIGHT POST BED MECHANISM

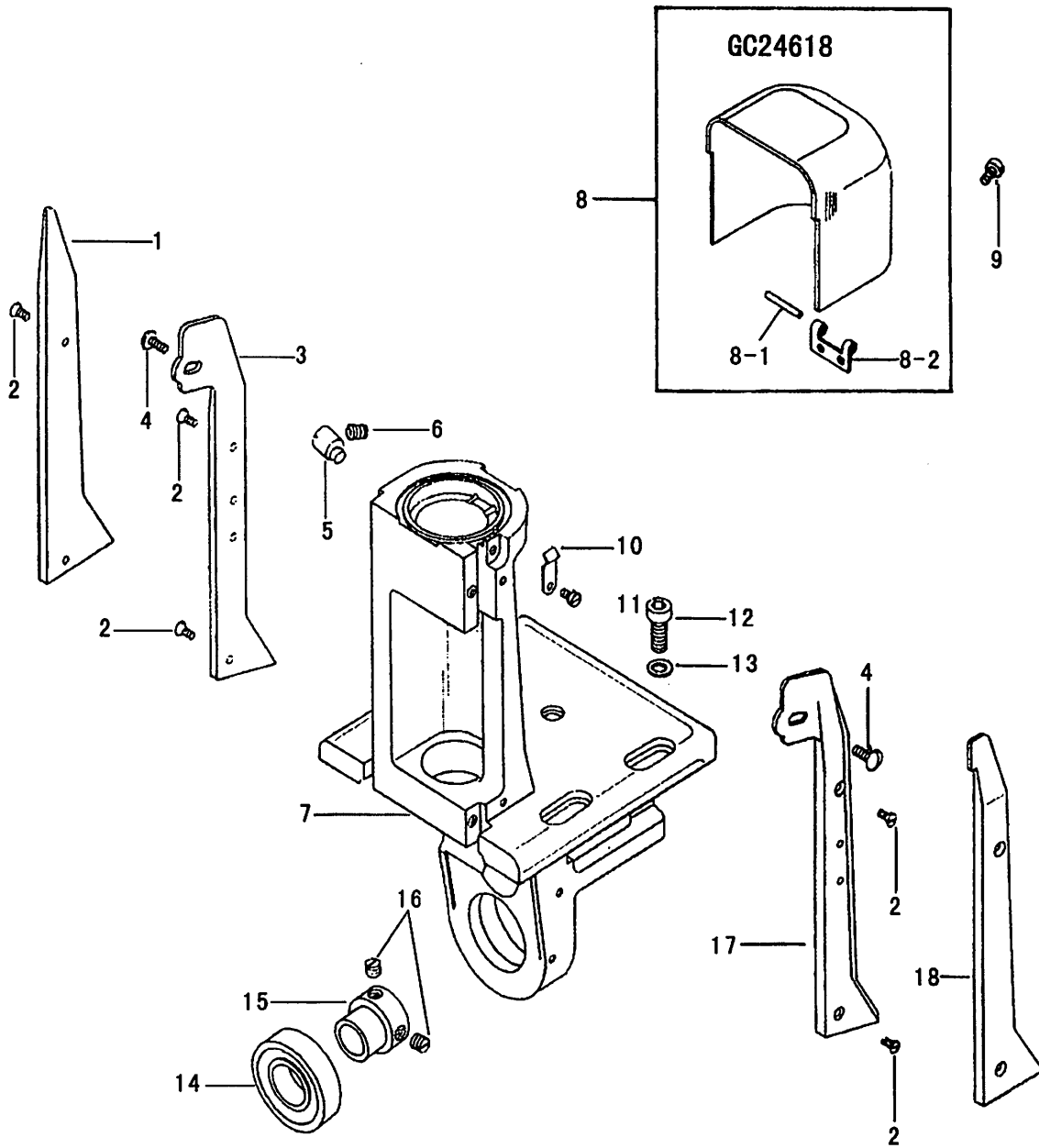

S. RIGHT POST BED MECHANISM

Ref. No.	Part No.	Name of part	GC24618	GC24618-1	Remarks
1	119695	Cover plate	0	1	
2	250084	Screw	4	4	
3	175267	Cover plate	1	0	
4	700336	Screw	2	0	
5	175318	Stud	1	1	
6	330217	Screw	1	1	
7	175324	Side bracket(right)	1	0	
7-1	119168	Side bracket(right)	0	1	
8	119436	Post cap assy.	1	0	
9	108093	Screw	2	0	
10	119143	Spring plate	1	1	
11	108093	Screw	1	1	
12	135292	Screw	4	4	
13	305174	Washer	4	4	
14	016120	Ball bearing	1	1	
15	119121	Collar	1	1	
16	700689	Screw	2	2	
17	175234	Cover plate	1	0	
18	119499	Cover plate	0	1	

T. BEARING DRIVING MECHANISM

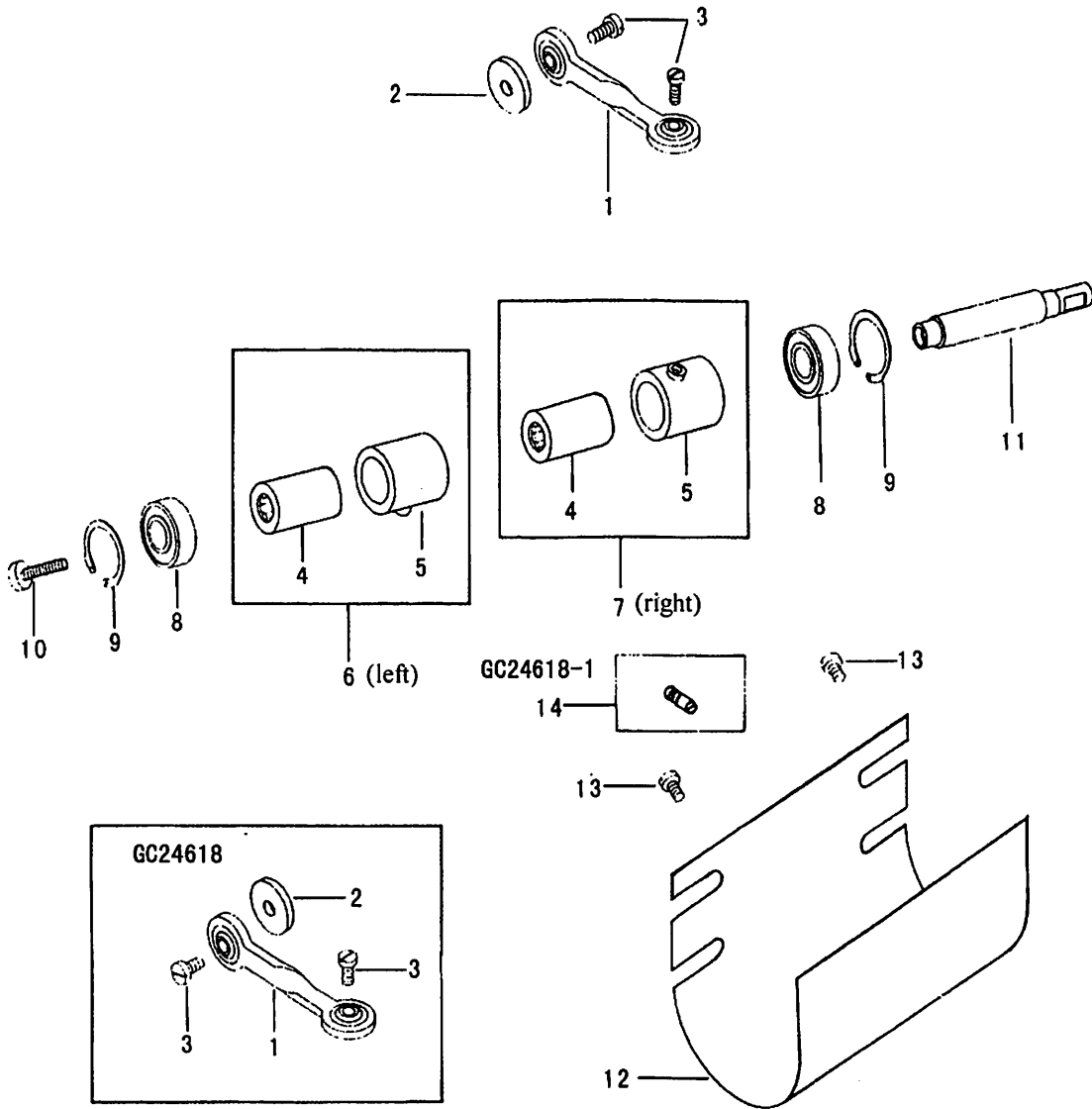

T. BEARING DRIVING MECHANISM

Ref. No.	Part No.	Name of part	GC24618	GC24618-1	Remarks
1	119507	Link	2	1	
2	119087	Oil felt	2	1	
3	174176	Screw	4	2	
4	061014	Needle bearing	2	2	
5	119115-1	Bearing socket	2	2	
6	119112	Bearing assy.(left)	1	1	(4, 5)
7	119115	Bearing assy.(right)	1	1	(4, 5)
8	012555	Ball bearing	2	2	
9	664350	C-ring	2	2	
10	173174	Screw	1	1	
11	119111	Bearing shaft	1	1	
12	119216	Cover plate	1	1	
13	108174	Screw	4	4	
14	119115-3	Screw	0	1	

U. RIGHT POST BED DRIVING MECHANISM

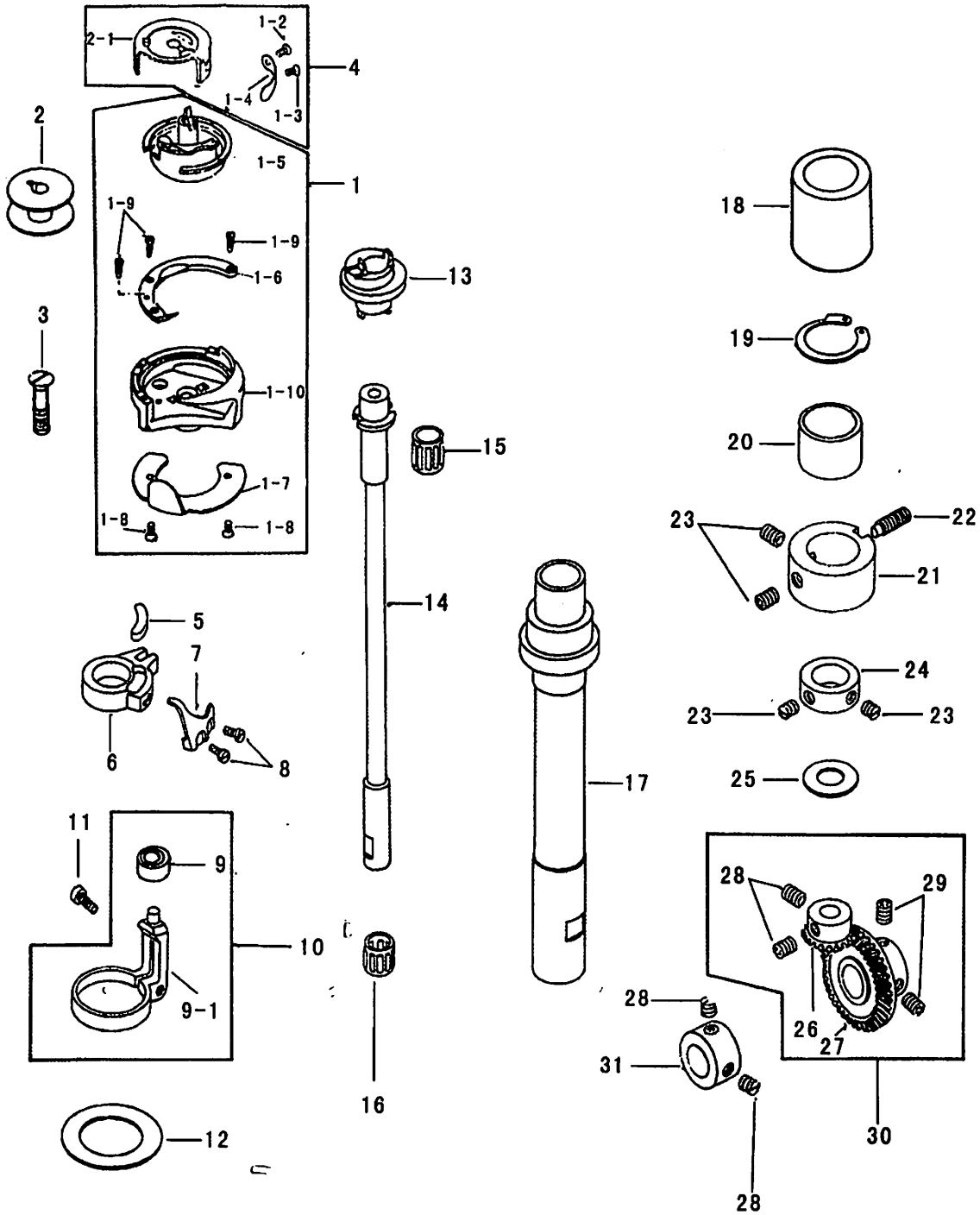

U. RIGHT POST BED DRIVING MECHANISM

Ref. No.	Part No.	Name of part	GC24618	GC24618-1	Remarks
1	119716A	Rotating hook assy.	1	1	(1-1-8)
1-2	000390	Screw	1	1	
1-3	000928	Screw	1	1	
1-4	010166	Spring	1	1	
1-5	119487	Bobbin case	1	1	
1-6	175136	Hook gib	1	1	
1-7	119377	Needle guard	1	1	
1-8	000219	Screw	2	2	
1-9	100529	Screw	3	6	
1-10	119376	Rotating hook	1	1	
2	010079	Bobbin	1	1	
2-1	010158	Bobbin case	1	2	
3	100205	Screw	1	2	
4	119716	Bobbin case assy.	1	1	
5	119128	Oil felt	1	1	
6	119127	Hook opener bracket	1	1	
7	119129	Rotating hook opener	1	1	
8	108093	Screw	2	2	
9	694ZZ	Ball bearing	1	1	(9)
9-1	119106-1	Opener holder	1	1	
10	119106	Opener holder assy.	1	1	
11	108177	Screw	1	1	
12	119105	Washer	1	1	
13	119525-1	Hook socket	1	1	
14	119525	Hook shaft	1	1	
15	215031	Needle bearing	1	1	
16	215028	Needle bearing	1	1	
17	119524	Bushing	1	1	
18	119979	Bushing	1	1	
19	664390	C-ring	1	1	
20	175138	Bushing	1	1	
21	119107	Collar	1	1	
22	119950	Screw	1	1	
23	341901	Screw	4	4	
24	131088	Collar	1	1	
25	125010	Washer(0.5)	2	2	
25-1	122718	Washer(0.1)	1	1	
25-2	125008	Washer(0.15)	1	1	
25-3	125009	Washer(0.2)	1	1	
26	119133-1	Bevel gear(large)	1	1	
27	119133-2	Bevel gear(small)	1	1	
28	700689	Screw	4	4	
29	341901-1	Screw	2	2	
30	119133	Bevel gear assy.	1	1	(26~29)
31	123778	Collar	1	1	

From the library of: Diamond Needle Corp

V. ACCESSORIES (1)

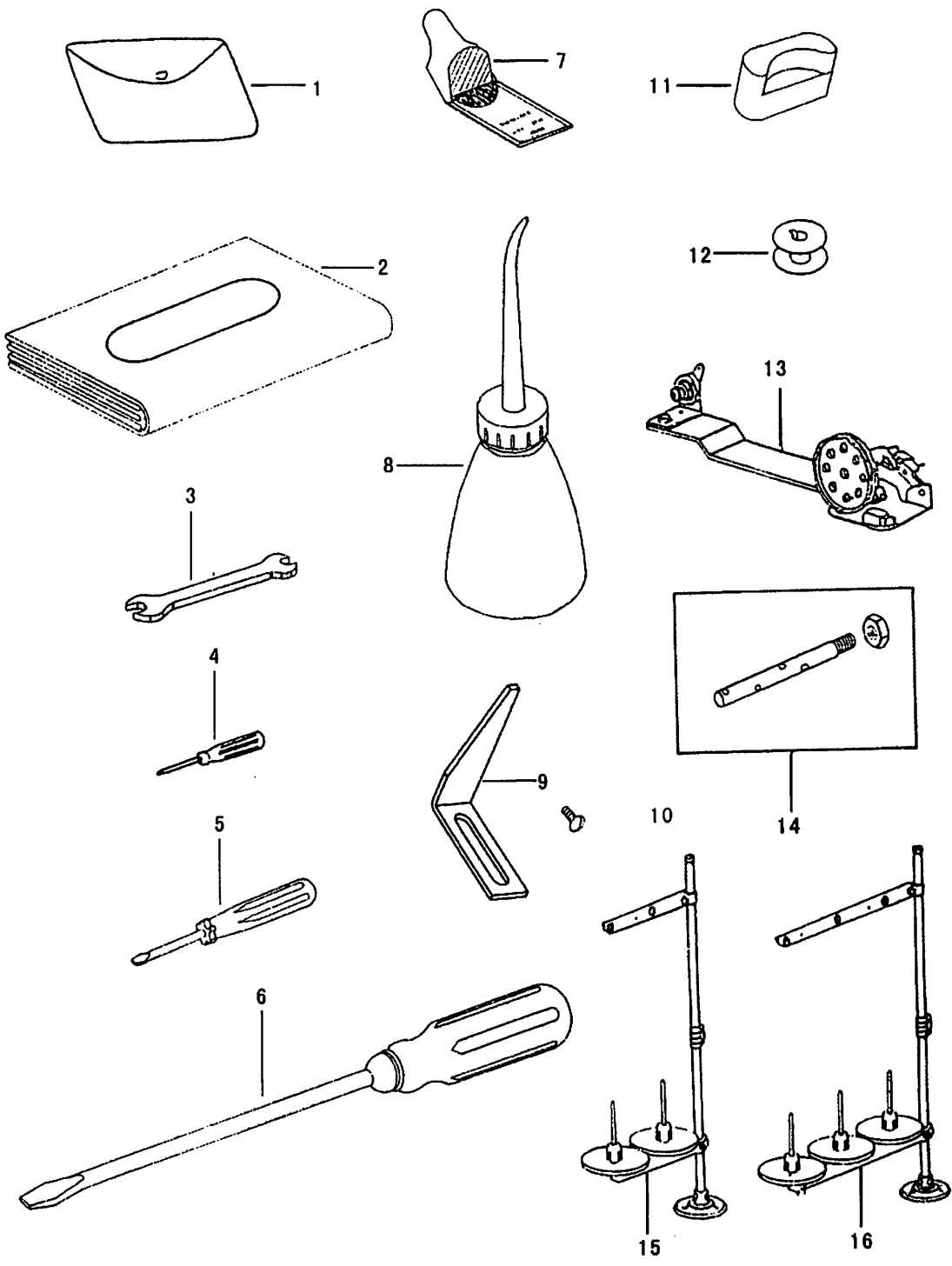

From the library of: Diamond Needle Corp

V. ACCESSORIES (1)

Ref. No.	Part No.	Name of part	GC24618	GC24618-1	Remarks
1	123456	Accessory bag	1	1	
2	029836	Vinyl cover	1	1	
3	800110	Spanner	1	1	
4	129915	Screw driver(small)	1	1	
5	029946	Screw driver(medium)	1	1	
6	029007	Screw driver(large)	1	1	
7	134356	Needle	10	10	
8	029394	Oiler	1	1	
9	119089-1	Stitch length indicator	1	1	
10	100355	Screw	1	1	
11	032808	Rubber cushion	2	2	
12	010079	Bobbin	4	4	
13	259431	Bobbin winder	1	1	
14	119026	Thread guide pin	1	1	
15	FPL2	Thread stand(2-pin)	1	0	
16	FPL3	Thread stand(3-pin)	0	1	

W. ACCESSORIES (2)

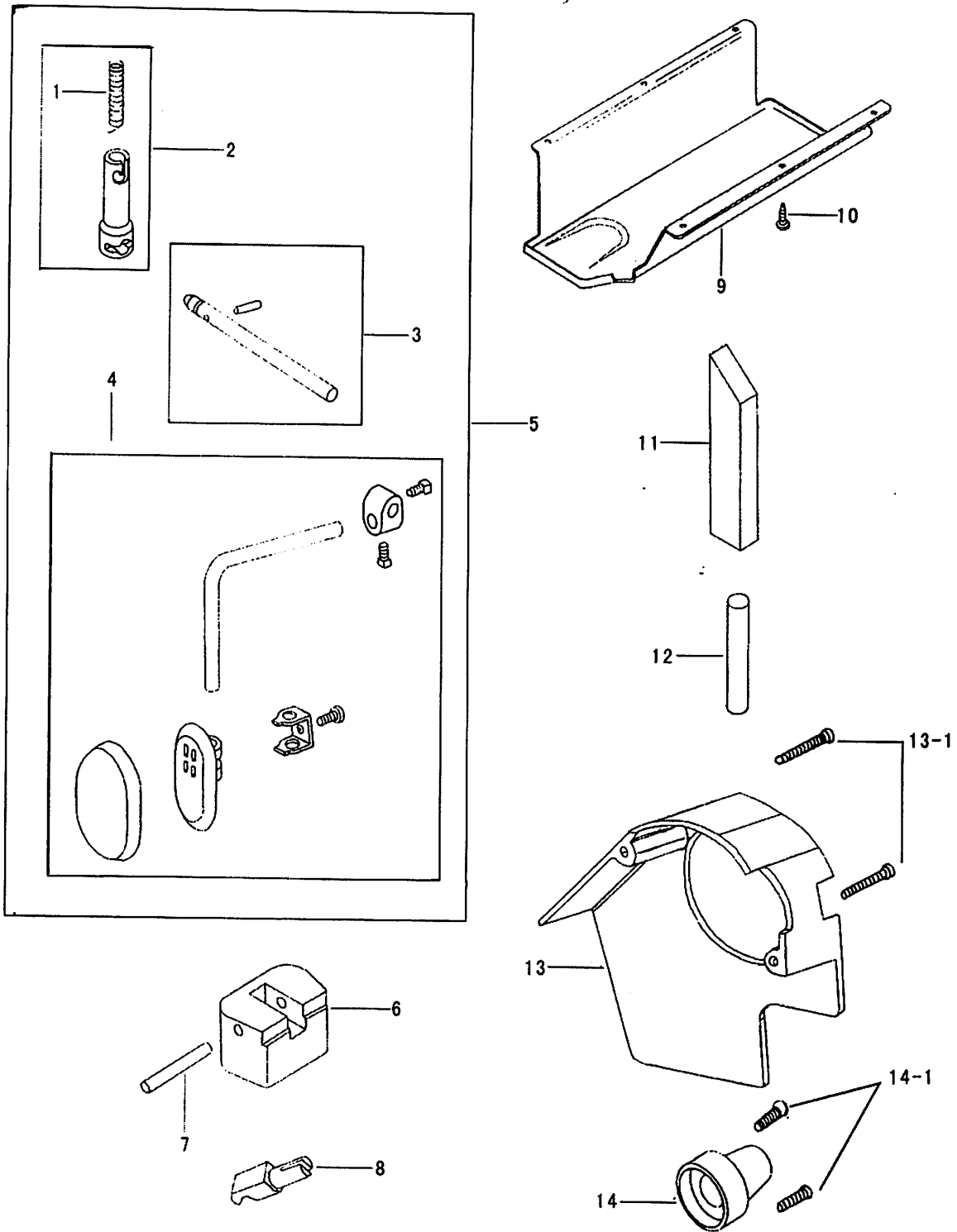

W. ACCESSORIES (2)

Ref. No.	Part No.	Name of part	GC24618	GC24618-1	Remarks
1	171543	Spring	1	1	
2	171542	Knee lifter coupling	1	1	
3	171413	Knee lifter rod	1	1	
4	171412	Knee lifter assy.	1	1	(2~4)
5	171411	Knee lifter lever assy.	1	1	
6	029934	Hinge socket	2	2	
7	030341	Pin	2	2	
8	029450	Hinge pin	2	2	
9	118636	Oil pan	1	1	
10	460157	Screw	6	6	
11	032717	Machine rest	1	1	
12	032717-1	Pin	1	1	
13	119078	Belt cover(large)	1	1	
13-1	119089-2	Screw	2	2	
14	119088	Belt cover(small)	1	1	
14-1	119078-1	Screw	2	2	

X. PRESSER FOOT FOR GC24618-1



1

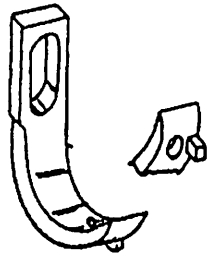

2

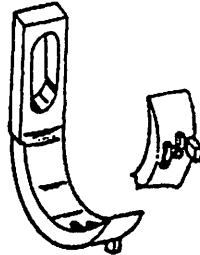

3

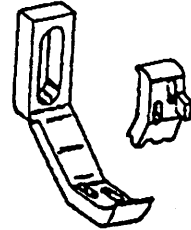

4

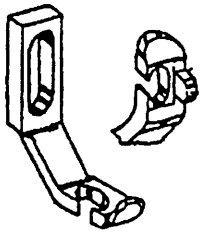

5

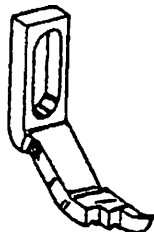

6

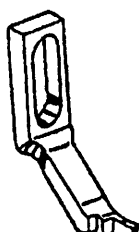

7

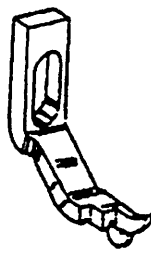

8

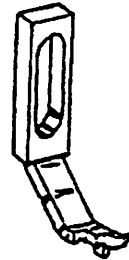

9

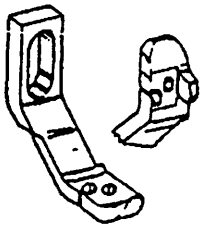

10

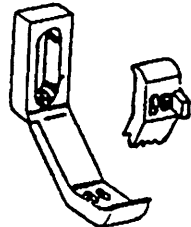

11

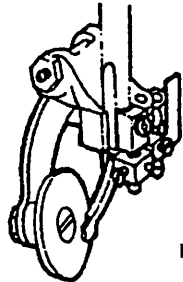

K2

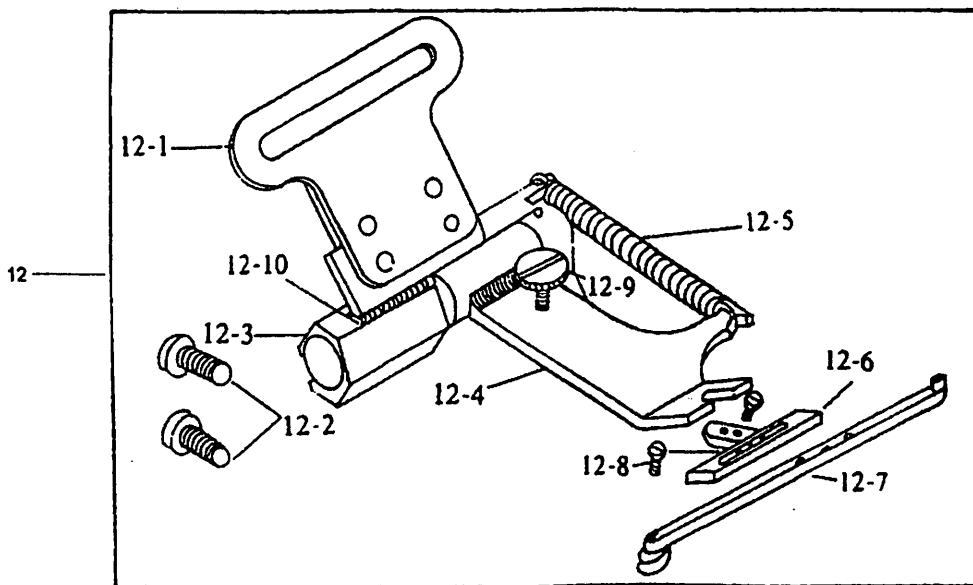

Y. THREAD TENSION MECHANISM

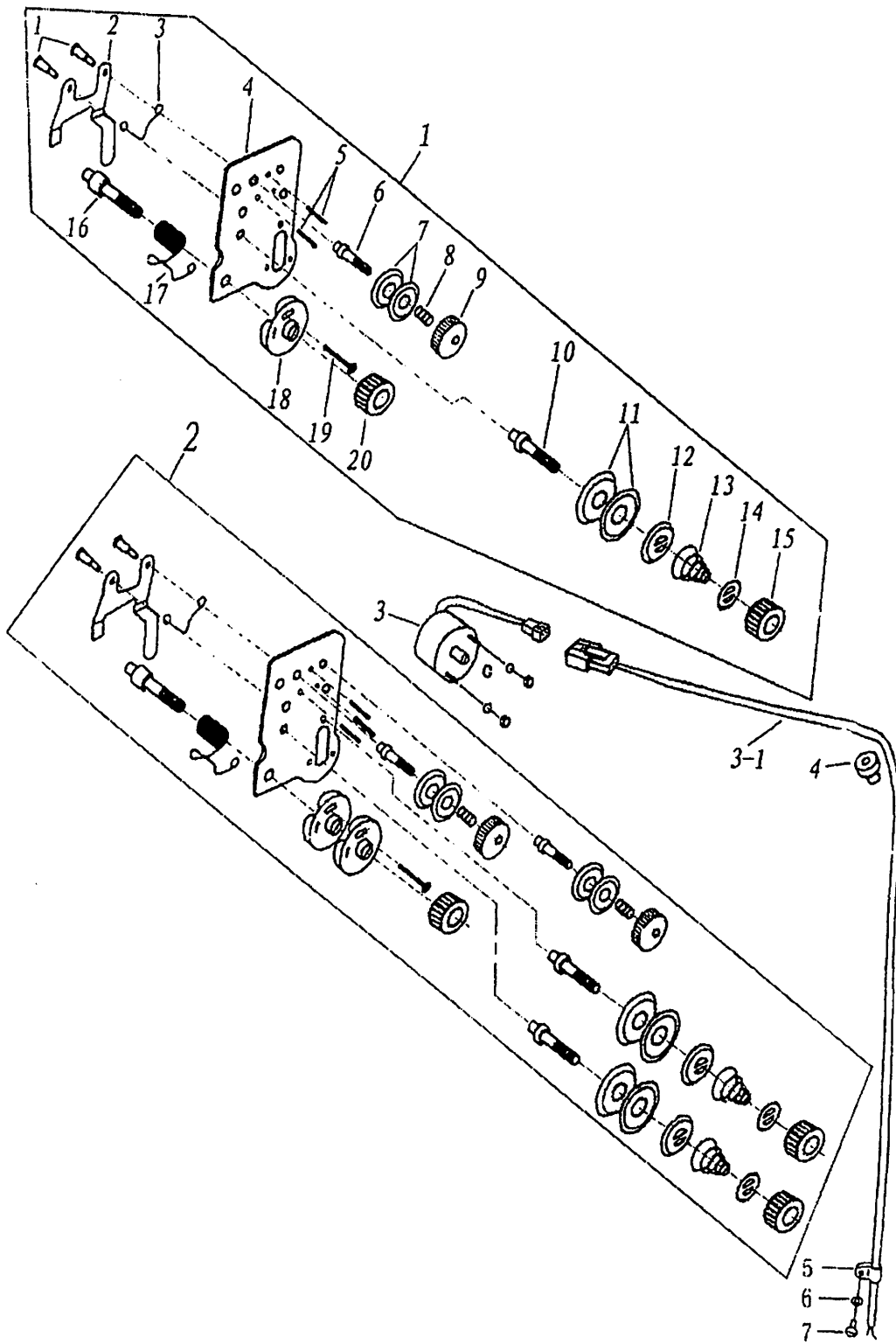

Y. THREAD TENSION MECHANISM

Ref. No.	Part No.	Name of part	GC24618-D	GC24618-1D	Remarks
1	7.02.01.055	Thread tension regulator assy.	1	0	
1-1		Screw	2	2	
1-2		Tension release plate	1	1	
1-3		Spring	1	1	
1-4		Upper tension release plate	1	1	
1-5		Pin	2	3	
1-6		Screw	1	2	
1-7		Tension disc	2	4	
1-8		Spring	1	2	
1-9		Nut	1	2	
1-10		Screw	2	2	
1-11		Tension release plate	1	4	
1-12		Tension disc	1	2	
1-13		Spring	1	2	
1-14		Stopper plate	1	2	
1-15		Nut	1	2	
1-16		Screw	1	2	
1-17		Spring	1	1	
1-18		Spring guide	1	2	
1-19		Nut	1	1	
1-20		Screw	1	1	
2	7.02.01.056	Thread tension regulator assy.	1	1	
3	7.02.19.013	Electromagnetism valve	1	1	
3-1		Power wire	1	1	
4	7.02.16.095	Rubber plug	1	1	
5	7.02.16.096	Fixed clip	1	1	
6	7.02.18.042	Washer	1	1	
7	7.02.15.006	Screw	1	1	

Z1. KNIFE ACTUATING MECHANISM(1)

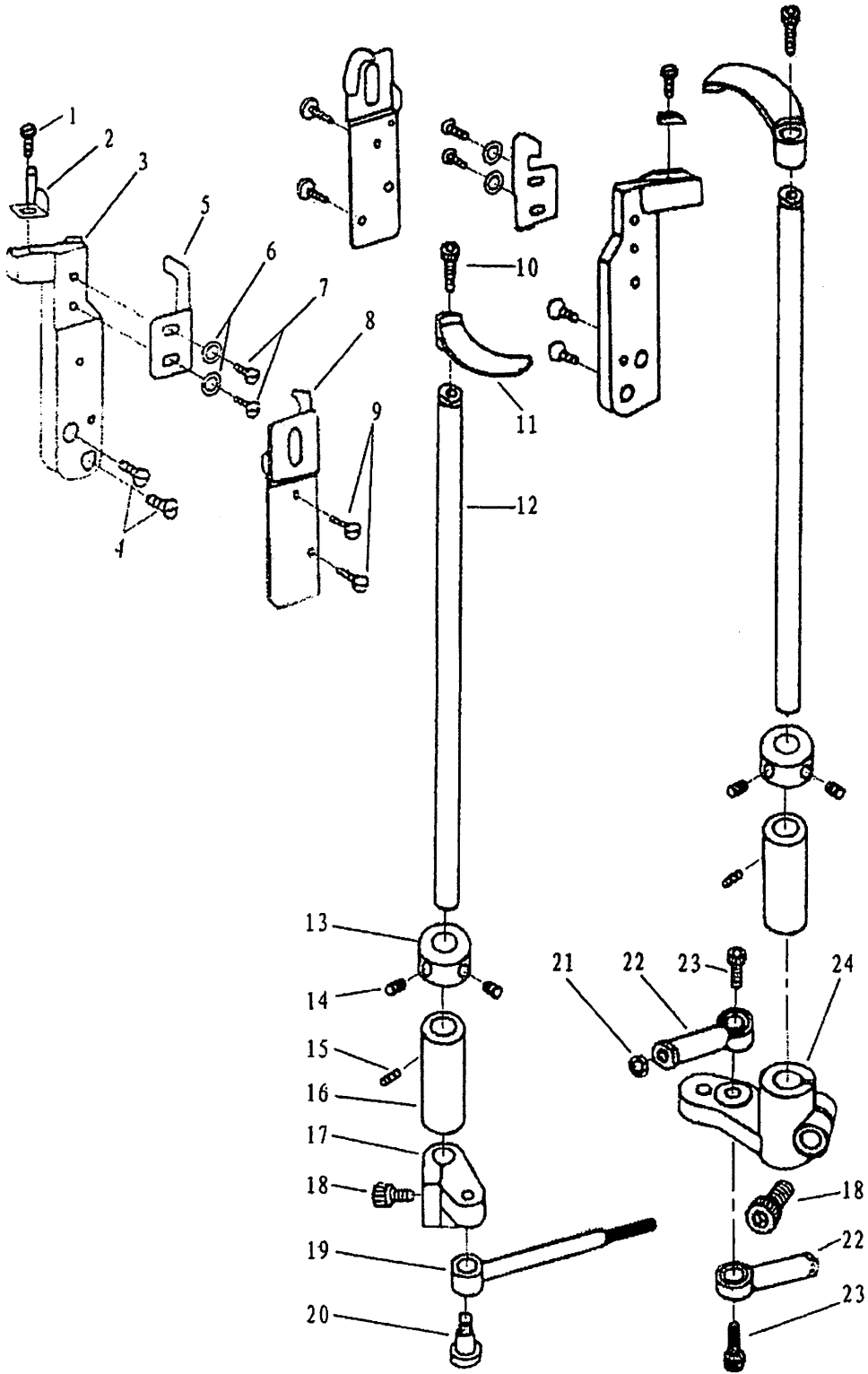

Z1. KNIFE ACTUATING MECHANISM(1)

Ref. No.	Part No.	Name of part	GC24618-D	GC24618-1D	Remarks
1	7.02.15.541	Screw	1	2	SM3/32 (56) × 3.5
2	7.02.17.123	Spring plate	1	2	
3	7.02.17.124	Fixed plate	1	2	
4	7.02.15.032	Screw	2	4	M4 × 6
5	7.02.20.020	Fixed blade	1	2	
6	7.02.18.121	Washer	2	4	
7	7.02.15.250	Screw	2	4	SM9/64 (40) × 6
8	7.02.11.08501	Cover board	1	2	
9	7.02.15.542	Screw	2	4	SM9/64 (40) × 4.5
10	7.02.15.063	Screw	1	2	M4 × 10
11	7.02.20.021	Moved knife	1	2	
12	7.02.10.124	Shaft	1	2	
13	7.02.09.040	Collar	1	2	
14	7.02.15.056	Screw	2	4	M5 × 5
15	7.02.15.047	Screw	1	2	M4 × 4
16	7.02.08.144	Bushing	1	2	
17	7.02.05.095	Crank	0	1	
18	7.02.15.053	Screw	1	1	M5 × 12
19		Link	0	1	
20		Screw	0	1	
21	7.02.15.068	Nut	0	1	
22	7.02.05.093	Link1	1	2	
23	7.02.15.543	Screw	1	2	
24	7.02.06.048	Crank	1	1	

Z2. KNIFE ACTUATING MECHANISM(2)

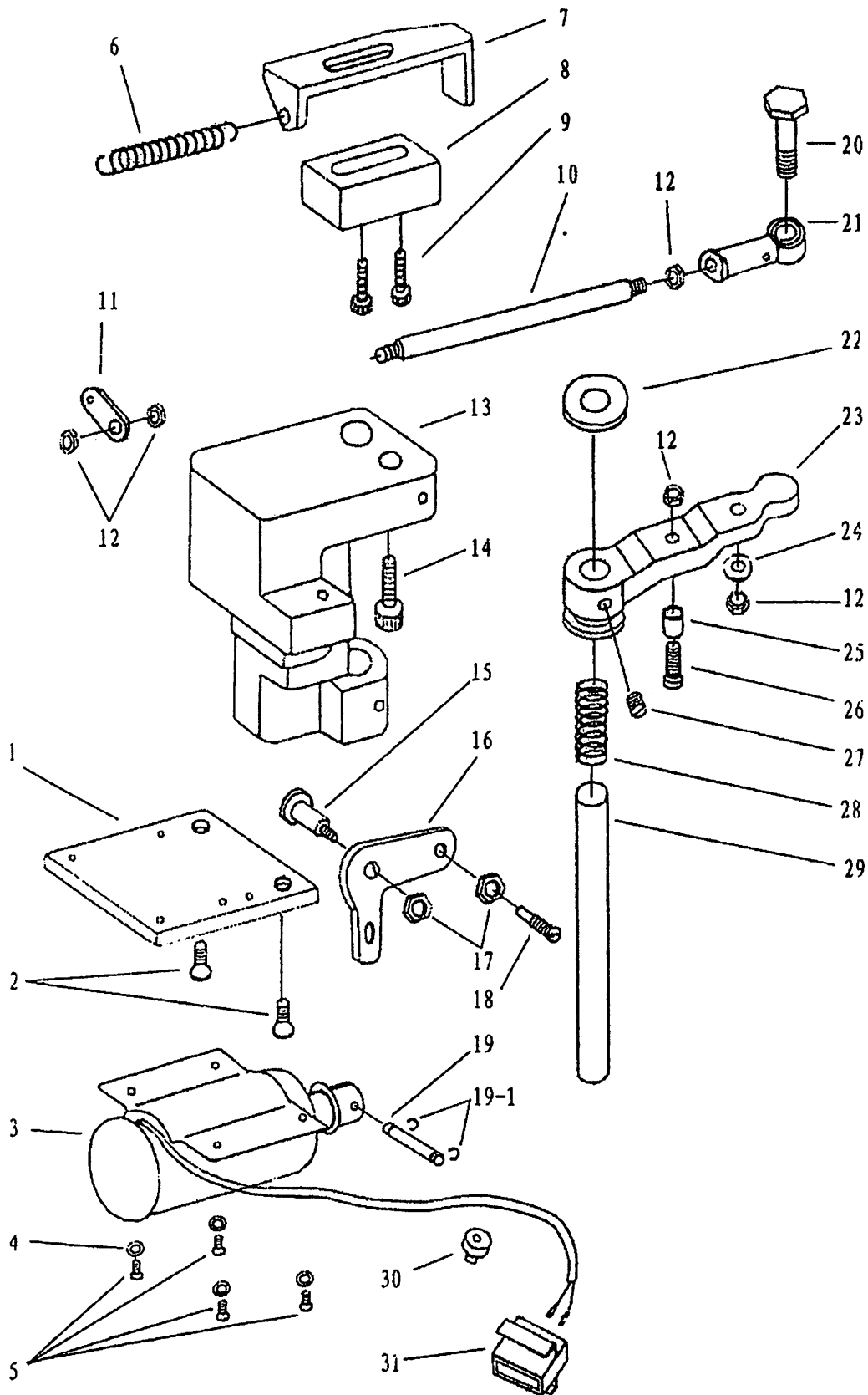

Z2. KNIFE ACTUATING MECHANISM(2)

Ref. No.	Part No.	Name of part	GC24618-D	GC24618-ID	Remarks
1	7. 02. 17. 125	Fixed plate	1	1	
2	7. 02. 15. 032	Screw	2	2	M4×6
3	7. 02. 19. 032	Electromagnetism valve	1	1	
4	7. 02. 18. 123	Washer	4	4	Φ5×Φ3×0.5
5	7. 02. 15. 037	Screw	4	4	
6	7. 02. 17. 120	Spring	1	1	
7	7. 02. 17. 129	Spring bracket	1	1	
8	7. 02. 12. 072	Stopper block	1	1	
9	7. 02. 15. 544	Screw	2	2	M5×20
10	7. 02. 05. 094	Connecting bar2	1	1	
11	7. 02. 17. 126	Spring plate	1	1	
12	7. 02. 15. 068	Nut	5	5	
13	7. 02. 13. 065	Set plate	1	1	
14	7. 02. 15. 545	Screw	2	2	M6
15	7. 02. 15. 546	Screw	1	1	
16	7. 02. 06. 049	Crank	1	1	
17	7. 02. 15. 067	Nut	2	2	M6
18	7. 02. 15. 547	Screw	1	1	M6
19	7. 02. 10. 123	Pin	1	1	
19-1		E-type ring	2	2	Φ2
20	7. 02. 15. 548	Screw	1	1	
21	7. 02. 05. 093	Connecting bar1	1	1	
22	7. 02. 18. 124	Rubber washer	1	1	
23	7. 02. 06. 050	Crank	1	1	
24		Washer	1	1	
25	7. 02. 08. 145	Slide roller	1	1	
26	7. 02. 15. 549	Screw	1	1	M5
27	7. 02. 15. 056	Screw	1	1	M5×5
28	7. 02. 17. 121	Spring	1	1	
29	7. 02. 10. 125	Crank shaft	1	1	
30	7. 02. 16. 095	Rubber plug	1	1	
31	7. 02. 19. 031	Socket	1	1	

SHANGHAI HUIGONG NO.3 SEWING MACHINE FACTORY

ADD: 1418, Yishan Road, Shanghai, China

Zip Code: 201103

Overseas Business: TEL: 86-21-64853303 FAX: 86-21-64854304

E-mail: highlead@online.sh.cn <http://www.highlead.com.cn>

The description covered in this manual is subject to change for improvement of the commodity without notice

2008.1 Printed