

B. THREAD TENSION REGULATOR MECHANISM

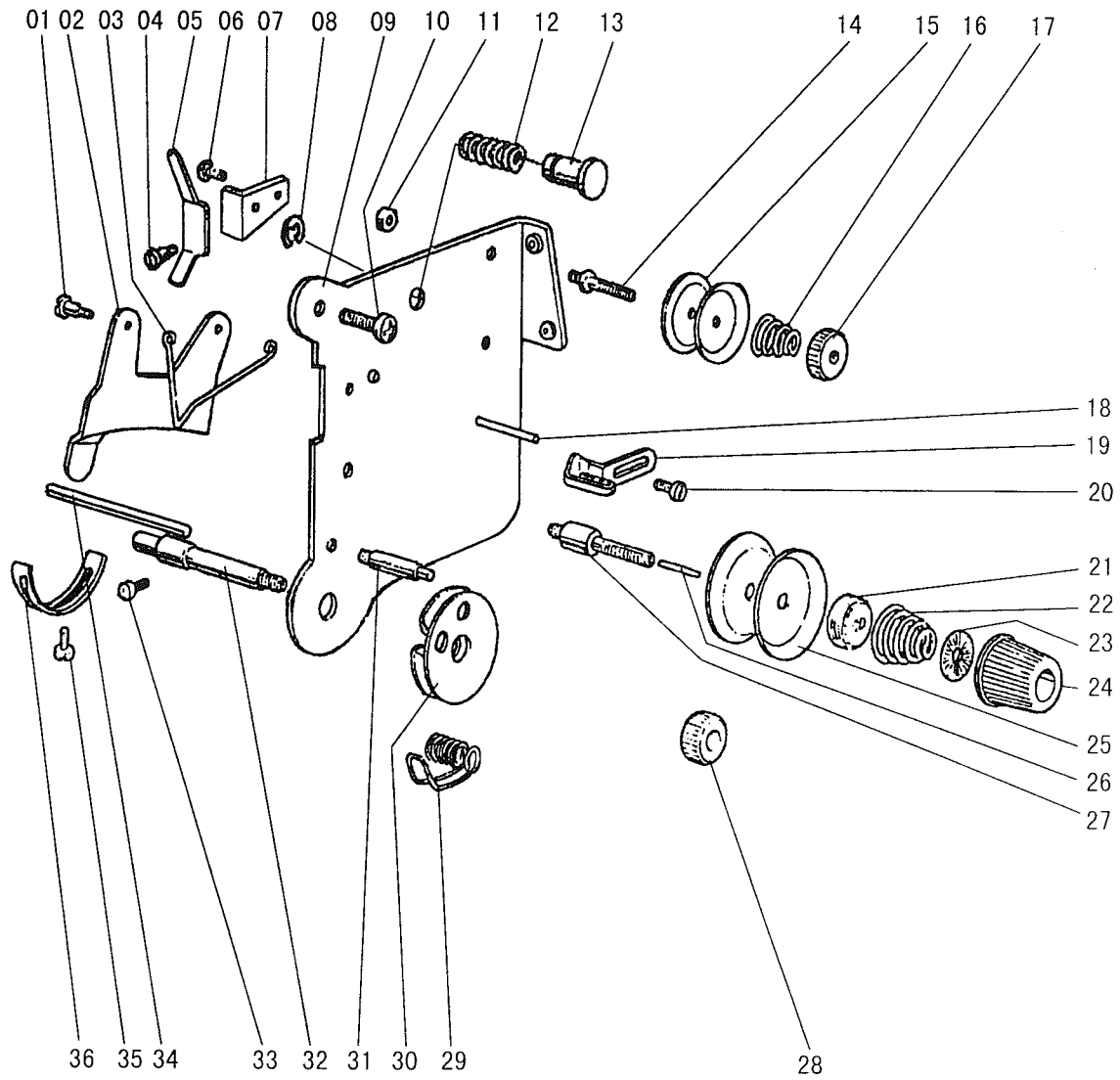

From the library of: Diamond Needle Corp

B.THREAD TENSION REGULATOR MECHANISM

Fig. No.	Part No.	Description	Pcs.	Remarks
B01	H2504C6510	Screw	2	9/64 (40) × 3
B02	H3221B3142	Tension releasing plate	1	
B03	H3221B6812	Tension releasing spring	1	
B04	H4705C8001	Screw	1	
B05	H4706C8001	Lever	1	
B06	HA7311C306	Screw	1	9/64 (40) × 5.5
B07	H4707C8001	Mounting plate	1	
B08	H007013050	E-type ring	1	
B09	H3221B6820	Mounting plate	1	
B10	HA300C2030	Screw	1	11/64 (40) × 8
B11	H3221B6810	Nut	2	
B12	H4708C8001	Spring	1	
B13	H4709C8001	Push button	1	
B14	H3221B0683	Thread tension stud	1	11/64 (40) × 14
B15	HA112B0693	Thread tension disc	2	
B16	H3300B2040	Spring	1	
B17	HA710B0671	Thumb nut	1	
B18	H3221B0682	Pin	2	
B19	HA106B0676	Screw	1	9/64 (40) × 6
B20	H3306B0661	Thread guide	1	
B21	HA310B0702	Tension releasing disc	1	
B22	H4710C8001	Spring	1	
B23	HA115B7010	Thumb nut revolution stopper	1	
B24	HA310B0701	Thumb nut	1	
B25	HA310B0705	Thread tension disc	2	
B26	H3221B0686	Thread tension stud	1	1/4 (40) × 23
B27	H32481B721	Thumb nut	1	
B28	H4713C8001	Thread take-up spring	1	
B29	H32481BD21	Plate complete	1	
B30	H4804C8001	Thread tension stud	1	9/64 (40) × 9
B31	H4805C8001	Thread tension stud	1	1/4 (40) × 14.5
B32	H3230K0751	Screw	1	11/64 (40) × 10
B33	H3221B6817	Pin	1	
B34	HG204C8001	Pin	1	
B35	H3200B2100	Screw	1	9/64 (40) × 6.5
B36	H3221B6819	Stopper	1	

C.TAKE-UP THREAD AND ARM SHAFT MECHANISM

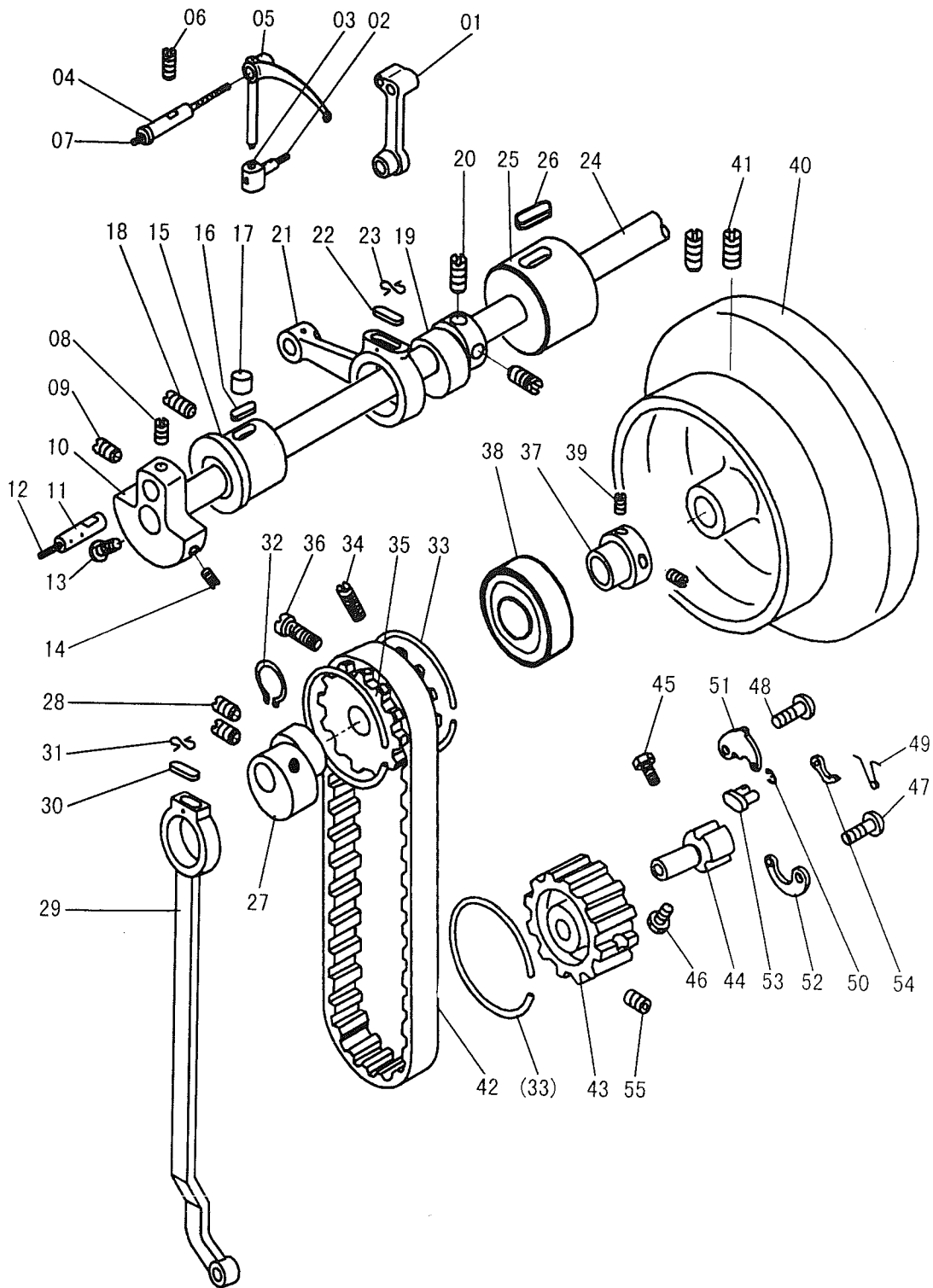

C.TAKE-UP THREAD AND ARM SHAFT MECHANISM

Fig. No.	Part No.	Description	Pcs.	Remarks
C01	H3100C2060	Needle bar connecting link	1	
C02	H3100C2050	Oil wick	1	
C03	H3100C2040	Thread take-up link	1	
C04	H0209F8001	Pin	1	
C05	H5305C8001	Thread take-up lever	1	
C06	HA100C2020	Set screw	1	15/64 (28) × 10
C07	H5306C8001	Holder	1	
C08	HA105D0662	Screw	1	1/4 (40) × 4
C09	HA307C0662	Screw	1	1/4 (40) × 6
C10	H5310C8001	Needle bar crank	1	
C11	H5311C8001	Pin	1	
C12	H2405D0663	Oil wick	1	
C13	HA100C2060	Screw	1	9/32 (28) × 13
C14	HA100C2070	Screw	1	9/32 (28) × 10
C15	H5315C8001	Arm shaft bushing (left)	1	
C16	H5316C8001	Felt	1	
C17	H5317C8001	Felt	1	
C18	HA100C2020	Screw	1	15/64 (28) × 10
C19	HG204D8001	Feed cam (left)	1	
C20	HA307C0662	Screw	2	1/4 (40) × 6
C21	HG205D8001	Upper feed driving rod	1	
C22	H2014J0068	Oil felt	1	
C23	H2000C2030	Felt retainer	1	
C24	H5314C8001	Arm shaft	1	
C25	H5326C8001	Arm shaft bushing (middle)	1	
C26	H5327C8001	Felt	1	
C27	H5332C8001	Feed cam (right)	1	
C28	HA307C0662	Screw	2	1/4 (40) × 6
C29	H5329C8001	Connecting rod for upper feed	1	
C30	H5330C8001	Felt	1	
C31	H20111C106	Holder	1	
C32	H007010260	Stop ring	1	
C33	H3205C0661	Spring stop ring	2	
C33	H3205C0661	Stop ring	1	
C34	HA113F0684	Screw	1	15/64 (28) × 8.5
C35	H5337C8001	Pulley (upper)	1	
C36	HA100F2130	Screw	1	15/64 (28) × 8
C37	H5336C8001	Arm shaft bushing (right)	1	
C38	H3208H0661	Needle bearing	1	6004ZZNR/5K
C39	HA113F0684	Screw	2	15/64 (28) × 8.5
C40	H4100C2040	Balance wheel	1	
C41	HA110D0672	Screw	2	15/64 (28) × 12
C42	H5338C8001	Cog belt	1	

C.TAKE-UP THREAD AND ARM SHAFT MECHANISM

Fig. No.	Part No.	Description	Pcs.	Remarks
C43	H5334D8001	Pulley	1	
C44	H5333D8001	Shaft for pulley	1	
C45	HA104F0654	Screw	1	15/64(28)×10
C46	H4721D8001	Screw	1	15/64(28)×8.5
C47	H4714D8001	Pin	1	
C48	H4718D8001	Pin	1	
C49	H4716D8001	Spring for pulley	1	
C50	H007013025	E-type stop ring	1	GB/T896 2.5
C51	H4719D8001	Short lever for pulley	1	
C52	H4713D8001	Long lever for pulley	1	
C53	H4715D8001	Pin	1	
C54	H4717D8001	Lever for pulley	1	
C55	H4723D8001	Screw	2	15/64(28)×4.5

D.NEEDLE BAR AND ROTATING HOOK SHAFT MECHANISM

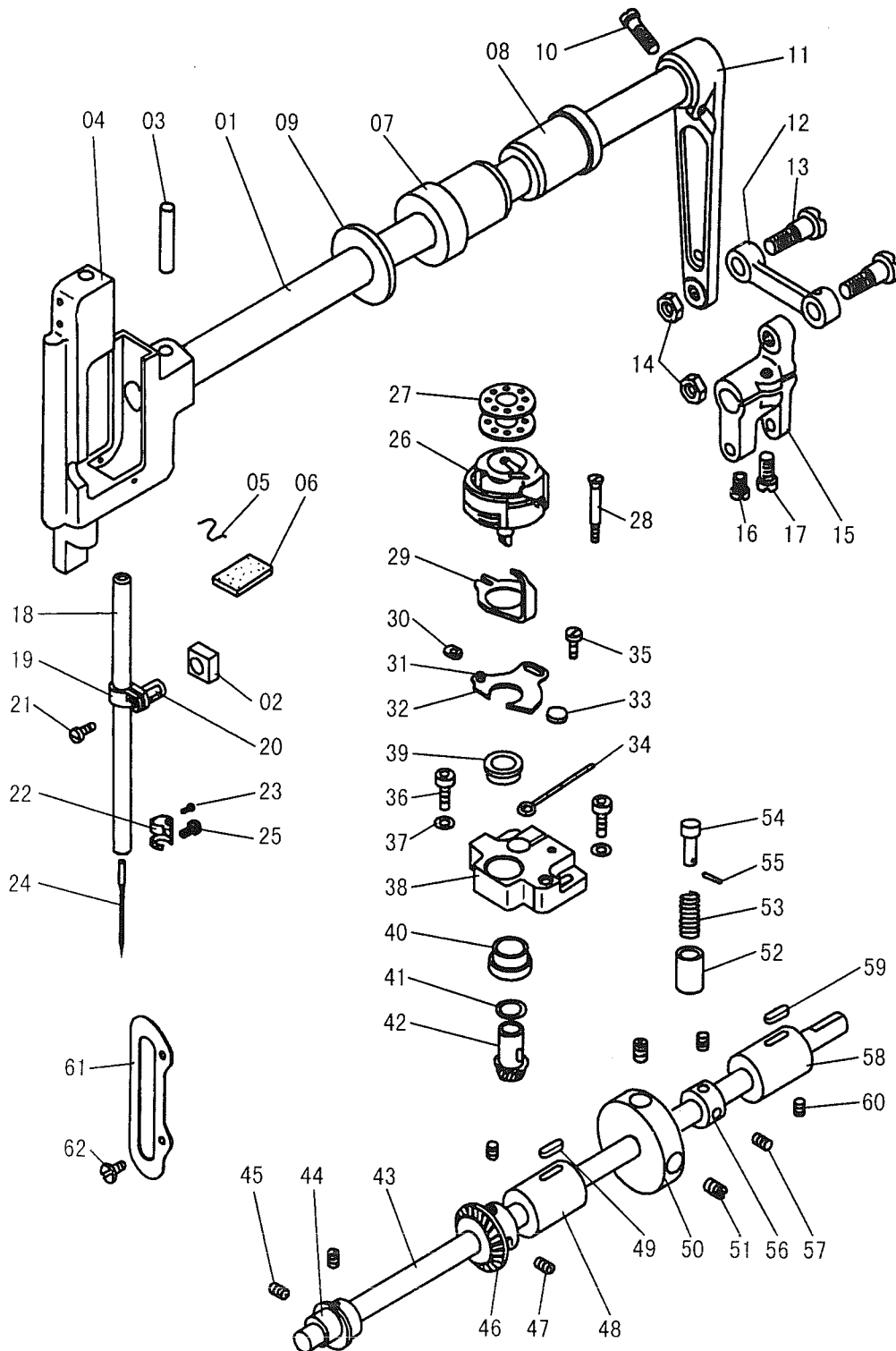

D.NEEDLE BAR AND ROTATING HOOK SHAFT MECHANISM

Fig. No.	Part No.	Description	Pcs.	Remarks
D01	H5325F8001	Needle bar rock shaft	1	
D02	H5324F8001	Slide block	1	
D03	H602040260	Pin	1	A4×26
D04	H5316F8001	Needle bar rock frame	1	
D05	H5319F8001	Felt	1	
D06	H5320F8001	Felt clip	1	
D07	H5328F8001	Needle bar rock shaft bushing (right)	1	
D08	H5327F8001	Needle bar rock shaft bushing (left)	1	
D09	H5326F8001	Washer	1	
D10	H5320H8001	Screw	1	15/64(28)×23.5
D11	H5319H8001	Link	1	
D12	H5316H8001	Link	1	
D13	H5317H8001	Screw	2	9/32(28)×13.3
D14	H2010J0066	Nut	2	9/32(28)×3.6
D15	H5314H8001	Crank	1	
D16	HA700F2100	Screw	1	11/64(40)×10
D17	HA800F2020	Screw	1	15/64(28)×13.5
D18	H3129F0692	Needle bar	1	
D19	H4722F8001	Needle bar connecting stud	1	
D20	H3204D6513	Felt	1	
D21	HA7311CD06	Screw	1	9/64(40)×8.5
D22	H5322F8001	Thread guide for needle bar	1	
D23	H3129F0691	Screw	1	3/32(56)×2.5
D24	H4740F8001	Needle	1	DP×17 #23
D25	HA100C2170	Screw	1	1/8(44)×4.5
D26	H5320D7101	Rotating hook	1	KRT341NR
D27	H1100E2010	Bobbin	1	BO-PF541
D28	H5337D8001	Screw	1	9/64(40)×10
D29	H5323D8001	Rotating position guide	1	
D30	H41622D216	Guide plate slide block	1	
D31	H410268D16	Guide plate pin	1	
D32	H5329D8001	Guide plate	1	
D33	H5326D8001	Felt	1	
D34	H5327D8001	Oil wick	1	
D35	H2204C0651	Screw	1	9/64(40)×5
D36	H425050120	Screw	2	M5×12
D37	H005004050	Washer	2	
D38	H5325D8001	Rotating hook bracket	1	
D39	HG208E8001	Bushing	1	
D40	HG209E8001	Bushing	1	
D41	HG210E8001	Washer	1	
D42	HG211E8001	Bevel gear for hook shaft	1	
D43	H5304D8001	Rotating hook shaft	1	

D.NEEDLE BAR AND ROTATING HOOK SHAFT MECHANISM

Fig. No.	Part No.	Description	Pcs.	Remarks
D44	H5306E8001	Feed eccentric	1	
D45	HA305E0662	Set screw	2	15/64(28)×4.5
D46	HG212E8001	Bevel gear for hook shaft	1	
D47	HA108C0663	Set screw	3	1/4(40)×7
D48	H5315D8001	Rotating hook shaft bushing (left)	1	
D49	H5316D8001	Oil wick		
D50	H5308D8001	Recessed wheel	1	
D51	HA3411D308	Set screw	2	15/64(28)×7
D52	H4107D0671	Safe clutch bushing	1	
D53	H4107D0672	Safe clutch spring	1	
D54	H5309D8001	Safe clutch shaft	1	
D55	H609020120	Safe clutch shaft pin	1	A2×12
D56	HG206E8001	Rotating hook shaft collar	1	
D57	HE051C8001	Screw	2	SM1/4"(40)×5.5
D58	HG205E8001	Rotating hook shaft bushing (right)	1	
D59	H5319D8001	Oil wick		
D60	HA3411D308	Screw	1	15/64(28)×7
D61	H5314F8001	Guide for slide block	1	
D62	HA700F2100	Screw	2	11/64(40)×7

E.PRESSER FOOT FEEDING MECHANISM

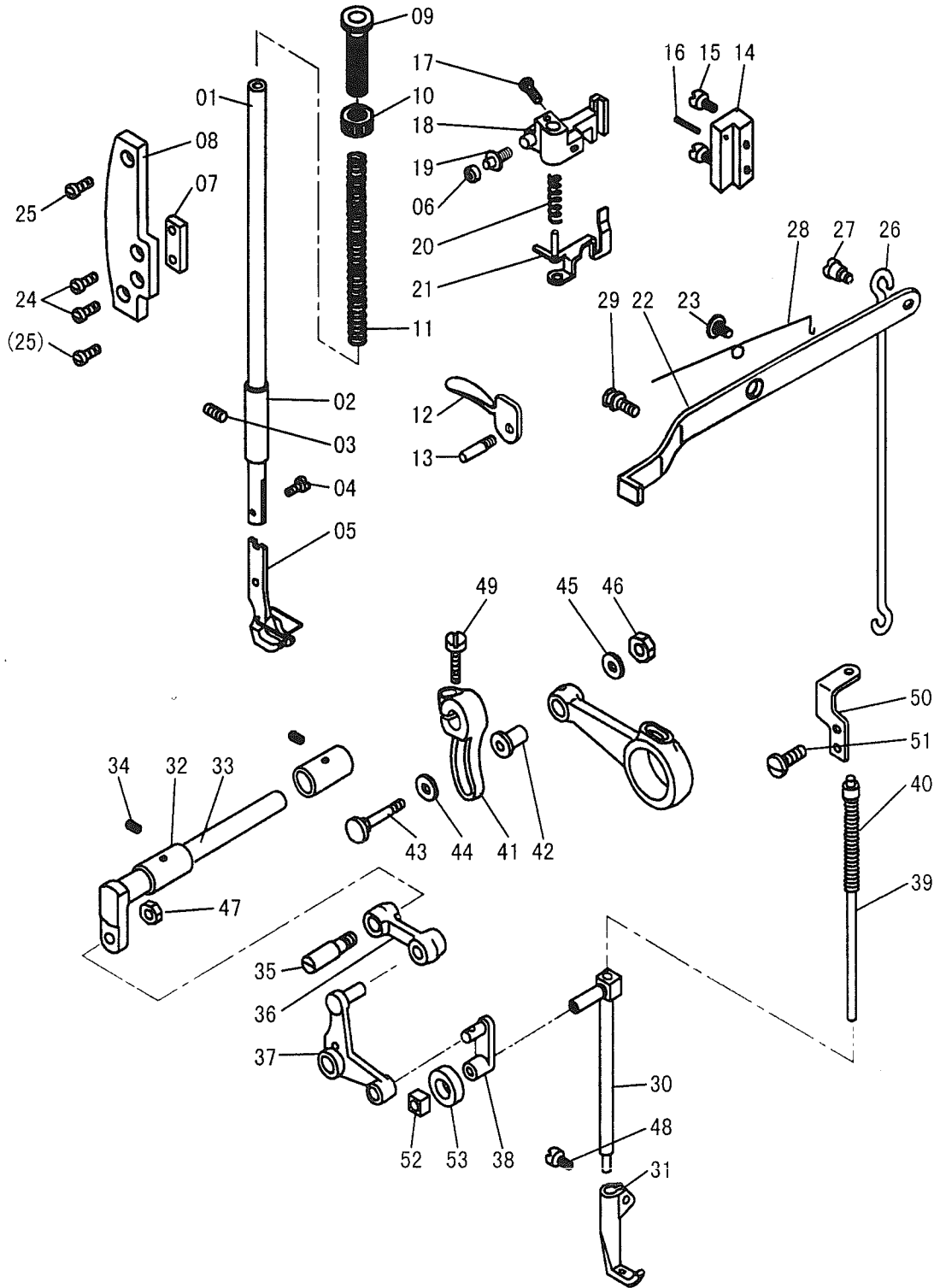

E.PRESSER FOOT FEEDING MECHANISM

Fig. No.	Part No.	Description	Pcs.	Remarks
E01	H4754E8001	Presser bar	1	
E02	HG204F8001	Presser bar lower bushing	1	
E03	HA100C2020	Screw	1	15/64(28)×10
E04	H3200E2020	Screw	1	1/8(44)×4
E05	H5331G8001	Presser foot acy	1	
E06	H2000J2030	Connecting pim roller	1	
E07	HG211F8001	Presser bar bracket guide	1	
E08	HG205F8001	Guide plate base	1	
E09	H2400G2140	Presser spring regulator	1	
E10	HA117H0692	Nut	1	1/2(28)
E11	HG206F8001	Presser spring	1	
E12	H3100G2070	Hand lifter	1	
E13	HG207F8001	Hand lifter pin	1	
E14	H3100G2210	Lifting bracket guide block	1	
E15	HE040D8001	Screw	1	17/64(24)×17.5
E16	H609025180	Pin	1	
E17	H3107G0661	Screw	1	11/64(40)×14
E18	HG208F8001	Presser lifting lever base	1	插图31H6-004B3
E19	H2004J0655	Guide shaft hinge screw	1	3/16(28)
E20	H3100G2050	Thread release spring	1	
E21	H3109G0651	Thread release guide assy	1	
E22	HG209F8001	Presser bar lifting lever	1	
E23	H3100G2130	Hinge screw	1	1/4(24)×7
E24	HA100C2190	Screw	2	11/64(40)×8
E25	HG210F8001	Screw	2	15/64(28)×10
E26	H5318G8001	Hanging rod	1	
E27	H5314G8001	Screw	1	3/16(28)×4.5
E28	H4727E8001	Twist spring	1	
E29	HG212F8001	Screw	1	
E30	H3100F2070	Walking bar	1	
E31	H5331F8001	Walking foot	1	
E32	H3100F2100	Bushing	2	
E33	H3112F0663	Upper feed driving shaft	1	
E34	HA100B2110	Screw	2	11/64(40)×5.5
E35	H3112F0661	Screw stud	1	1/4(28)
E36	H3100F2010	Upper feed dconnecting link	1	
E37	H3100F2020	L shaped link	1	
E38	H3100F2030	Walking bar driving link	1	
E39	H5332F7101	Walking bar spring	1	
E40	H2000J2120	Walking bar spring	1	
E41	H3115F0672	Upper feed spring rod	1	
E42	H3100F2150	Connecting stud	1	
E43	H3100F2130	Hinge screw	1	7/32(32)

E.PRESSER FOOT FEEDING MECHANISM

Fig. No.	Part No.	Description	Pcs.	Remarks
E44	HE045D8001	Washer	1	
E45	H4728H8001	Washer	1	
E46	H3100F2160	Nut	1	7/32(32)
E47	H3112F0662	Nut	1	1/4(28)
E48	HA100C2040	Screw	1	11/64(40)×5.5
E49	H3115F0671	Screw	1	1/4(28)×16
E50	H5334F8001	Walking bar retaining plate	1	
E51	H2004J0067	Screw	2	9/64(40)×7
E52	H5315F8001	Walking bar guide roller	1	
E53	HG213F8001	Felt	1	

F. STITCH REGULATOR MECHANISM

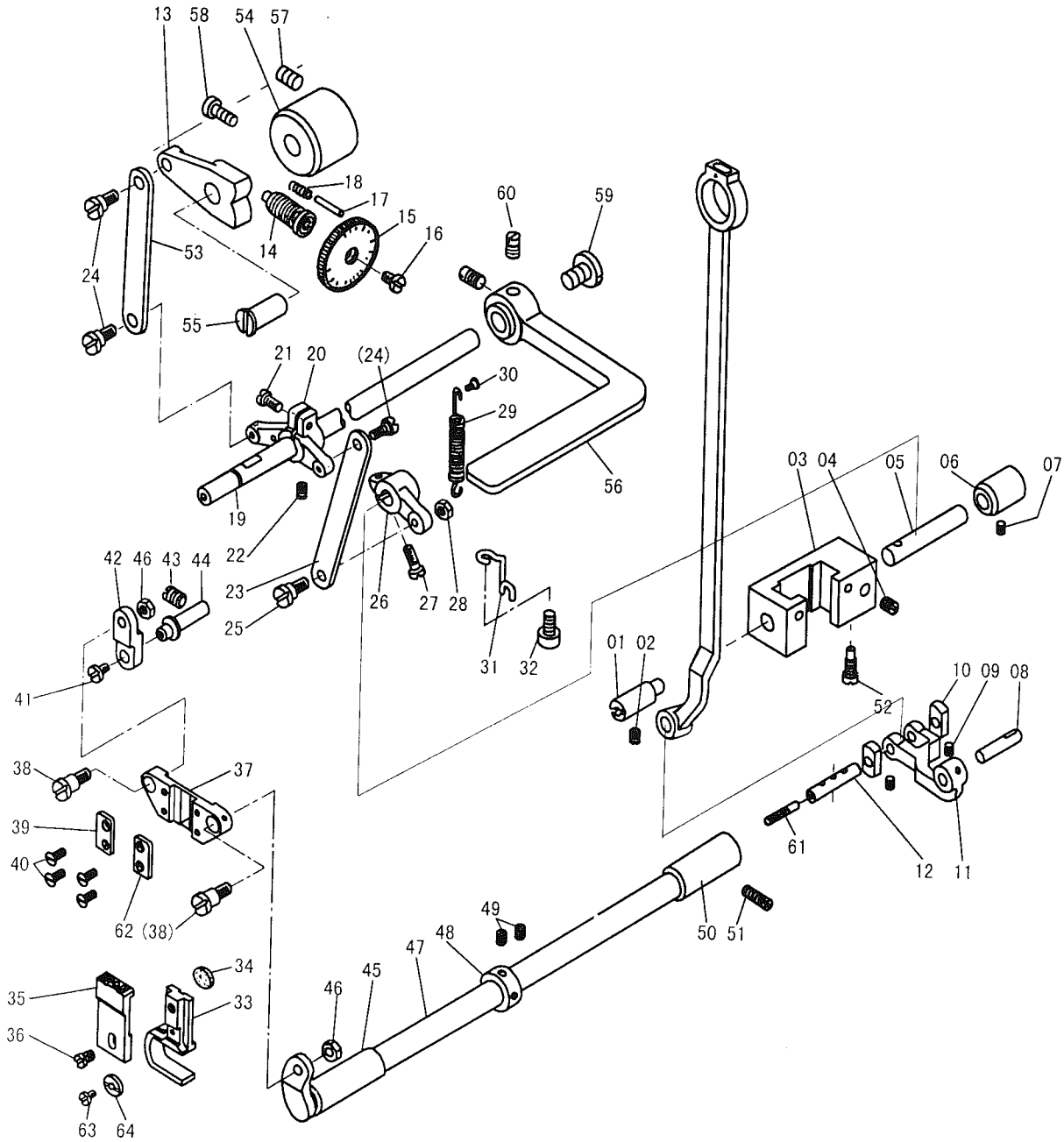

F.STITCH REGULATOR MECHANISM

Fig. No.	Part No.	Description	Pcs.	Remarks
F01	H5308H8001	Feed driving rocker hinge pin	1	
F02	HA100C2020	Screw	1	15/64(28)×10
F03	H5305H8001	Feed driving rocker	1	
F04	HA100F2130	Screw	1	15/64(28)
F05	H5306H8001	Feed driving rocker shaft	1	
F06	H5307H8001	Bushing	1	
F07	HA3411D308	Screw	1	15/64(28)×7
F08	H5315H8001	Feed rocker shaft crank pin	1	
F09	HA711B0681	Screw	2	9/64(40)×4.5
F10	H5309H8001	Slide block	2	
F11	H5313H8001	Feed driving rocker arm	1	
F12	H5311H8001	Slide block shaft	1	
F13	H5334H8001	Feed regulator	1	
F14	HA720F0681	Needle feed regulating spring.	1	
F15	HA7421F120	Stitch dial assy	1	
F16	HA720F0686	Screw	1	3/16(28)×12
F17	HA700F2030	Pin	1	
F18	HA100F2090	Spring	1	
F19	H5339H8001	Reverse feed lever shaft	1	
F20	H5327H8001	Control lever crank	1	
F21	H5343H8001	Screw	1	3/64(32)×16
F22	HA3411D308	Screw	1	15/64(28)×7
F23	H5323H8001	Control lever crank link A	1	
F24	H5333H8001	Hinge screw	3	3/16(32)×8.5
F25	H5324H8001	Hinge screw	1	3/16(32)×13.5
F26	H5322H8001	Feed driving rocker shaft arm	1	
F27	HA104G0012	Screw	1	3/16(28)×12
F28	H5325H8001	Nut	1	3/16(32)
F29	HG207G8001	Tension spring	1	
F30	H5329H8001	Hinge screw	1	9/64(40)×4
F31	H5330H8001	Suspension hook	1	
F32	H2000I2050	Screw	1	9/64(40)×8
F33	HG205G8001	Feed bar crank	1	
F34	H41111E204	Oil felt	1	
F35	H5304E8001	Feed dog	1	
F36	HA700F2100	Screw	1	11/64(40)×7
F37	H5307E8001	Feed bar support	1	
F38	H5315E8001	Hinge screw	2	1/4(40)×9
F39	H5308E8001	Feed bar support plate	1	
F40	H5309E8001	Screw	4	1/8(44)×6.3
F41	H5314E8001	Screw	1	11/64(40)×7.5
F42	H5312E8001	Feed bar link	1	
F43	HA100C2020	Screw	1	15/64(28)×10

F.STITCH REGULATOR MECHANISM

Fig. No.	Part No.	Description	Pcs.	Remarks
F44	H5313E8001	Feed rocker link shaft	1	
F45	H5320E8001	Bushing front	1	
F46	H5316E8001	Nut	2	1/4 (40)
F47	H5317E8001	Feed rocker shaft	1	
F48	H5319E8001	Thrust coolar	1	
F49	H6039G8001	Screw	2	11/64(40)×3.8
F50	H5321E8001	Bushing rear	1	
F51	HA100C2020	Screw	1	15/64(28)×10
F52	HA100F2130	Screw	1	15/64(28)
F53	H5332H8001	Feed lever connecting link B	1	
F54	H5338H8001	Feed regulator bushing	1	
F55	H5335H8001	Hinge pin	1	
F56	H5342H8001	Feed lever	1	
F57	HA3411D308	Screw	1	15/64(28)×7
F58	H5336H8001	Screw	1	15/64(28)×14.3
F59	HA113F0683	Screw	1	3/16(28)×6.5
F60	HA113F0684	Screw	2	15/64(28)×8.5
F61	H5312H8001	Oil wick	1	
F62	H5310E8001	Feed bar support	1	
F63	HE114E8001	Screw	1	11/64(40)×4
F64	HE115E8001	Stop ring	1	

G.ACCESSORIES

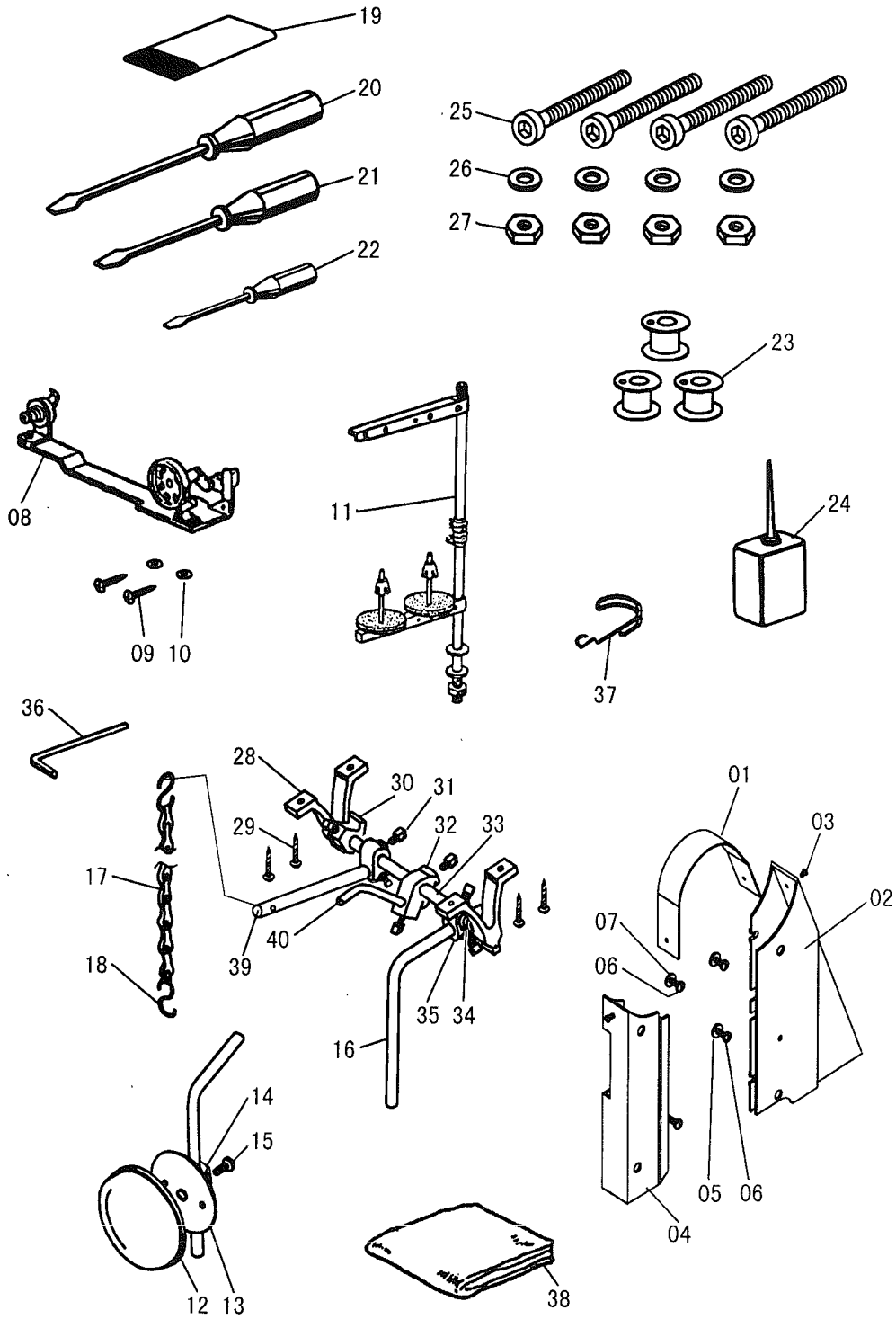

G.ACCESSORIES

Fig. No.	Part No.	Description	Pcs.	Remarks
G01	H6307L8001	Belt cover (upper)	1	
G02	H5311I8001	Belt cover (right)	1	
G03	H2000O0360	Screw	2	11/64(40)×6
G04	H5312I8001	Belt cover (left)	1	
G05	H6722N8001	Washer	1	
G06	H0207L8001	Screw	4	15/64(28)×8
G07	H0206L8001	Washer	2	
G08	HA706S0067	Bobbin winder assy	1	
G09	H801045200	Wood screw	2	4.5×20
G10	HA300J2230	Washer	2	5
G11	HA200J2030	Thread stand assy	1	
G12	HA106J0668	Knee lifter cover	1	
G13	HA106J0665	Knee lifter plate	1	
G14	HA106J0666	Knee lifter bracket	1	
G15	HA106J0667	Screw	1	
G16	HA106J0662	Knee lifter shaft	1	
G17	HPG100E203	Chain	1	
G18	HPG100E202	S shaped hook	2	
G19	H4740F8001	Needle	2	DP×17 23#
G20	HA300J2070	Screw driver (large)	1	
G21	HA300J2200	Screw driver (middle)	1	
G22	HA300J2210	Screw driver (small)	1	
G23	H1100E2010	Bobbin	2	
G24	H2004O0069	Oil assy	1	
G25	H403080750	Screw	4	M8×75
G26	H005001080	Washer	4	
G27	H003002080	Nut	4	M8
G28	H2015O0065	Knee lifter	2	
G29	H1802045250	Wood screw	4	4.5×25
G30	H2015O0067	Set blore	1	
G31	HA300J2180	Screw	5	
G32	H2015O0069	Knee lifter shaft	1	
G33	H2015O0066	Knee lifter shaft	1	
G34	H2016O0070	Coil spring	1	
G35	H5313I8001	Connector	1	
G36	HB00001060	Socket wrench	1	6mm
G37	HE204I8001	Finger gusrd	1	
G38	HA100J2180	Vinyl cover	1	
G39	HG208H8001	Lever	1	
G40	H3104H0651	Knee lifter shaft	1	

SHANGHAI HUIGONG NO.3 SEWING MACHINE FACTORY

ADD: 1418, Yishan Road, Shanghai, China

Zip Code: 201103

Overseas Business: TEL: 86-21-64853303 FAX: 86-21-64854304

E-mail: highlead@online.sh.cn <http://www.highlead.com.cn>

The description covered in this manual is subject to change for improvement of the commodity without notice

2008.2. Printed