



**GC22618-1B**

**Cylinder-Bed Unison Feed  
Sewing Machine**

**INSTRUCTION MANUAL  
CATALOG**

---

## 1. Safety precautions:

1) When turning the power on, keep your hands and fingers away from the area around/under the needle and the area around the pulley.

2) Power must be turned off when the machine is not in use, or when the operator leaves the seat.

3) Power must be turned off when tilting the machine head, installing or removing the “V” belt, adjusting the machine, or when replacing.

4) Avoid placing fingers, hairs, bars etc., near the pulley, “V” belt, bobbin winder pulley, or motor when the machine is in operation.

5) Do not insert fingers into the thread take-up cover, under/around the needle, or pulley when the machine is in operation.

## 2. Precautions before starting operation:

1) When a new sewing machine is first turned on, verify the rotational direction of the pulley with the power on.

2) Verify the voltage and phase (single or three) with those given on the machine nameplate.

## 3. Precautions for operating conditions:

1) Avoid using the machine at abnormally high temperatures (35°C or higher) or low temperatures (5°C or lower) .

2) Avoid using the machine in dusty conditions.

## 4. Specifications:

Max. Sewing Speed (rpm)	2,200	
Needle	DP×17 22#	
Needle Bar Stroke (mm)	34.2	
Thread Take-up Lever Stroke (mm)	72.1	
Max.Stitch Length (mm)	6	
Presser Foot Stroke	By hand (mm)	8
	By knee (mm)	14
Alternating Movement (mm)	2.0-6.0	

## 5. Preparation before starting operation:

### 1) Cleaning the machine

Before leaving the factory, the machine parts are coated with rust-preventive grease, which may be hardened and contaminated by dust during storage and shipment. This grease must be removed with gasoline.

### 2) Examination

Though every machine is inspected and tested strictly before leaving the factory, the machine parts may be loose or deformed after long distance transportation with jolt. A thorough examination must be performed after cleaning the machine. Turn the balance wheel to see if there is running obstruction, parts collision, uneven resistance or abnormal noise. If these exist, adjustment must be made accordingly before run-in operation.

### 3) Lubrication

When a new machine begins to be used or an old machine which left out of use for a long time is to be used again, it must be lubricated fully. (The spots which arrowheads direct need to be lubricated. Fig.1)

**Please use white spindle oil**

**Please uplift presser foot when the machine is operated without material.**

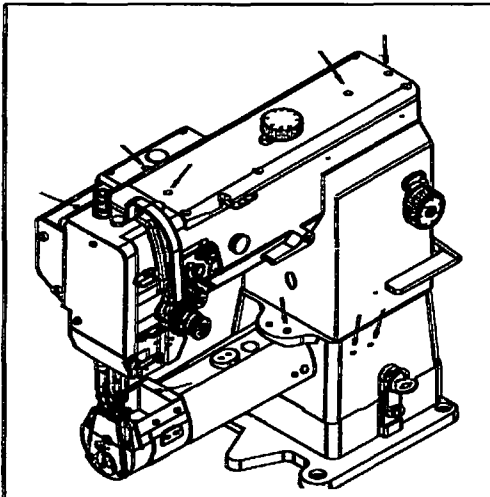

Fig.1

#### 4) Run-in operation

A new machine runs at a low speed (1600rpm) for about a month after being lubricated sufficiently, each of parts will achieve its best state. Then increasing speed to the maximum according to the nature of the work must be done.

### 6. How to attach a needle (Fig.2):

**Note:** Before attach the needle, be sure to turn the power switch off.

This machine 's needle size is DPX17 #22. Needle size must be selected according to the thread rightly. (Thread need to pass the pinhole of the needle freely.)

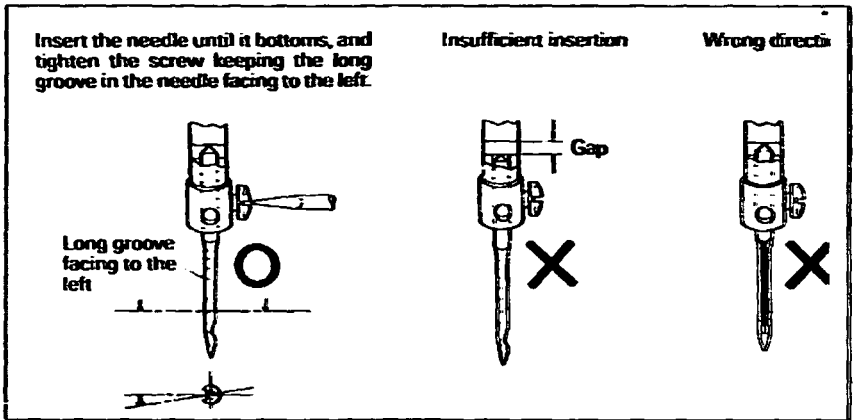

Fig. 2

### 7. Winding the lower thread: (Fig.3):

1) Push a bobbin on the bobbin winder spindle (3) as far as it will go.

2) Pull out the thrum and wind thread around the bobbin for several circles clockwise;

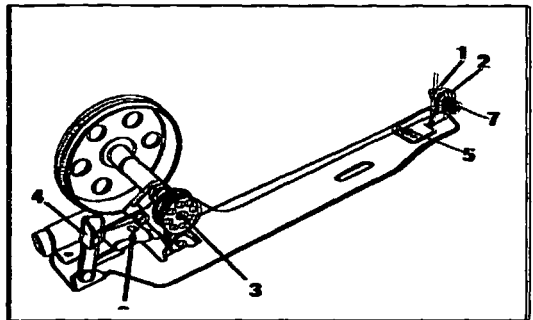

Fig. 3

3) Push the lever 4 backward so that the wheel of the pulley touches the “V” belt, then start the machine.

4) The pulley will separate from the “V” belt automatically after the bobbin is filled with thread.

## 8. Adjustment of the bobbin winder: (Fig.3):

1) In case of uneven winding

Loosen the screw 5 in the tension bracket and move the bracket to the right or to the left as may be required.

2) Adjustment of the amount of the thread

Adjusting screw 6 can adjust the amount of the thread. Tightening the screw will increase the amount, otherwise the amount of the thread will decrease.

3) Winding strength

Adjusting the nut 7 can adjust the winding strength.

Adjusting screw 6 can adjust the amount of the thread. Tightening the screw will increase the amount, otherwise the amount of the thread will decrease.

## 9. How to route the upper thread (Fig.4):

Raise needle bar to its highest possible position, and perform threading as shown in Fig.

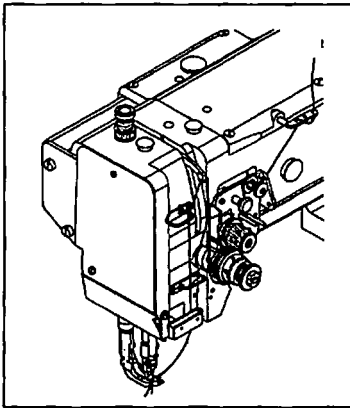

Fig.4

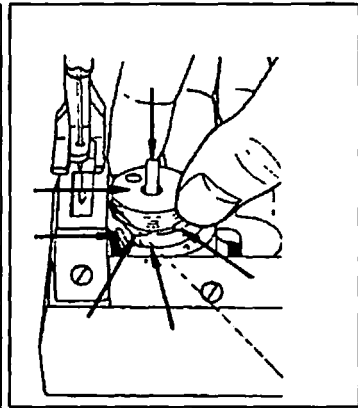

Fig.5

## 10. Removing and inserting the bobbin (Fig.5):

1) Taking out the bobbin: open the cover, take out the bobbin.

2) Inserting the bobbin: replace the bobbin into the shuttle bobbin case, shutdown the cover. Be sure to make the bobbin rotate counterclockwise and pull out the thrum.

## 11. Adjustment of the thread tension (Fig.6、 7、 8):

1) The tension of the upper and lower thread must be equal so as to adopt normal stitch.

(Fig.6 a)

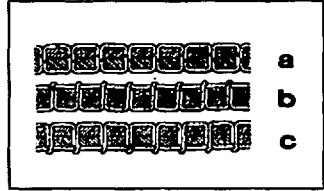

Fig.6

2) Tension of the upper thread (Fig.7)

Before adjusting the tension of the upper thread, it should be certain that the presser foot is let down but not in other position. Adjusting the thumb nut can adjust the tension of the upper thread. Rotating the thumb nut clockwise, the tension of the upper thread will increase. Otherwise, the tension of the upper thread will decrease.

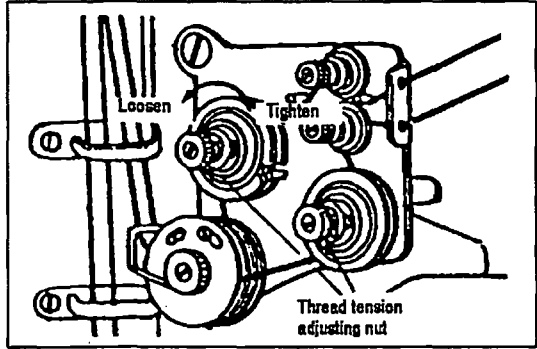

Fig.7

3) Tension of the lower thread (Fig.8)

Turning the large screw clockwise will increase the tension of the lower thread.

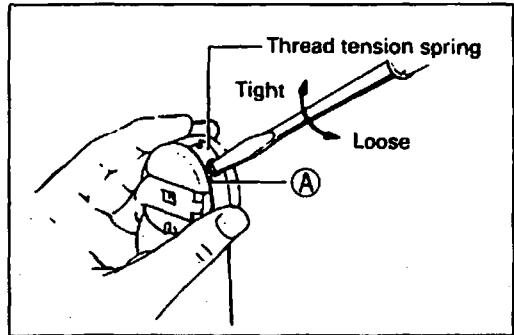

Fig.8

Otherwise, the tension of the lower thread will decrease.

## 12. Adjustment of presser foot pressure (Fig.9):

1) Pressure should be adjusted according to the material to be sewn.

2) Pressure on both the walking foot and the presser foot can be adjusted.

3) Sewing pressure should be adjusted to the minimum required strength.

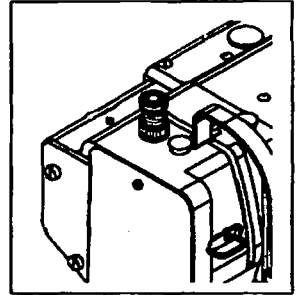

Fig.9

## 13. Adjustment of walking foot and presser foot:

### 1) Adjustment of alternating movement (Fig.10):

(1) The alternating movement on the walking foot and presser foot can be adjusted by using adjusting dial located on the top cover.

(2) Face the desired number printed on the dial to the matching mark located on the top cover. The number printed on the dial represents the possible protrusion of the walking foot and presser foot from the throat plate when the alternating movements on these are evenly set.

(3) The alternating movements can be readjusted up to 2.0-6.0mm.

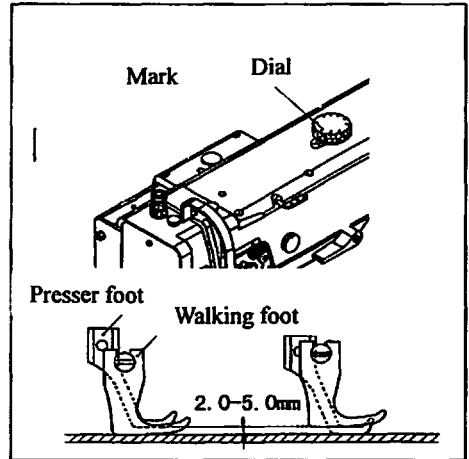

Fig.10

2) To change the balance of the alternating movements between the walking foot and presser foot (Fig.11):

(1) To increase the rise of the walking foot and decrease the rise of the presser foot:

① Remove the rubber plug of top cover.

② Rotate the pulley until the presser foot is slightly raised from the throat plate.

③ Loosen screw "A" (on the right side)

④ The built-in spring pulls down the presser foot until it makes contact with the throat plate. Tighten the screw "A".

⑤ After this adjustment, the protrusion of the presser foot has been decreased by a set distance. And the same distance has increased the vertical motion of the walking foot.

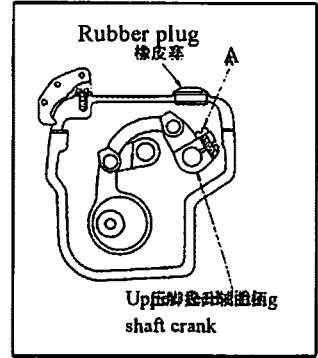

Fig.11

(2) As a contrary case (1) , to decrease the rise of the walking foot and increase the rise of presser foot as follows:

First, rotate the pulley until the walking foot is slightly raised from the throat plate. Next, loosen screw "A". Finally, tighten screw "A". This decreases the rise of the walking foot.

3) Installing the feed regulator bracket (Fig.12):

**Note:** If the feed regulator bracket is poorly positioned, the resultant alternating movements may be too short or long, causing defective machine operation.

(1) Set the clearance between special screw "A" located on the regulator stud and the side wall of the machine arm to 26.5mm as Fig.12.

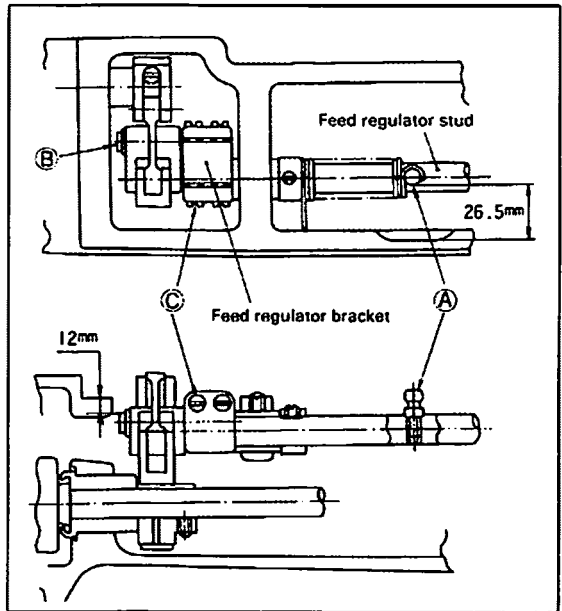

Fig.12



(2) With the feed regulator stud held as explained in step (1) above, adjust the feed regulator bracket. This adjustment should insure a clearance of 12mm between the periphery of pin "B" located on the feed regulator bracket and the top cover mounting face located on the arm. Tighten screw "C".

#### 4) Feed pitch adjustment of walking foot (Fig.13):

The ratio of the upper feed amount (of the walking foot) to the lower feed amount (of the feed dog) has been adjusted to 1:1. However, the walking foot feeding amount can be increased or decreased depending on the operating conditions. Loosen the nut located on the upper feed rock shaft crank (left), and shift to adjust the position of the pivot bracket upward or downward.

Upper position → Feed pitch → Small

Lower position → Feed pitch → Large

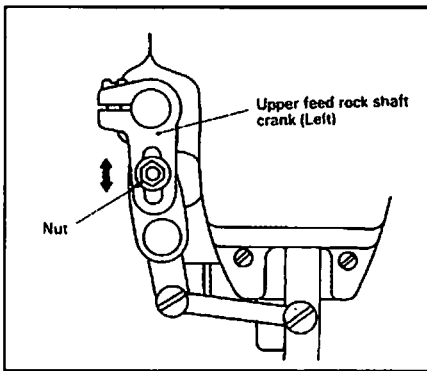

Fig.13

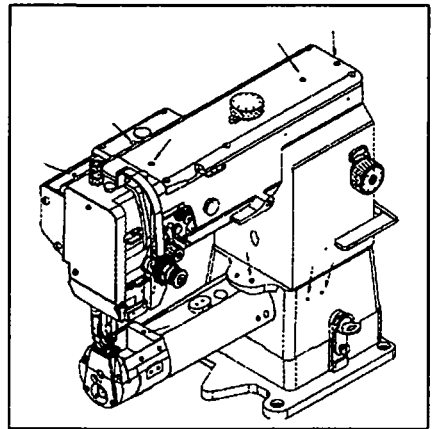

Fig.14

### 14. Adjustment of stitch length and reverse sewing (Fig.14):

- 1) To change the stitch length, rotate the stitch length adjusting dial.
- 2) Pressing the stitch length adjusting lever for reverse stitching.

### 15. Safety clutch device: (Fig.15、 16、 17、 18):

Safety clutch device is installed to prevent the hook and cog belt from

damage in case the thread is caught into the hook when the machine is loaded abnormally during operation.

### 1) Function of safety clutch.

(1) When the safety clutch acts, the cog belt pulley will be unloaded. Then the rotation of hook shaft will stop. The arm shaft only will rotate. Stop the operation of machine.

(2) Clean the thread thoroughly which is caught into the hook.

(3) Turn the cog belt hub by hand, and check

Whether the hook shaft rotates lightly and properly, place the clutch device as follows.

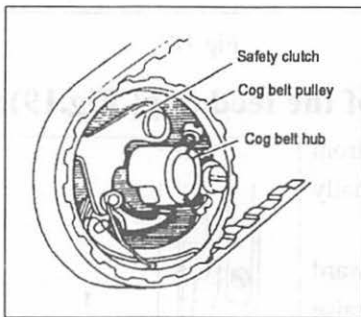

Fig.15

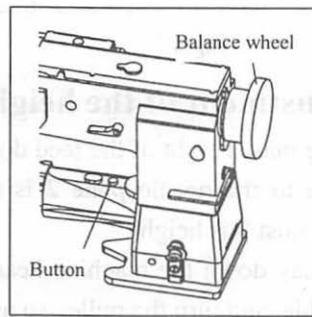

Fig.16

### 2) How to set the safety clutch.

(1) While pressing down the push button on the opposite side of bed by left hand, turn the balance wheel slowly by right hand away from you as shown in the figure.

(2) The balance wheel will stop by the gear plate, but turn the balance wheel more firmly.

(3) Release the push button.

(4) As shown in the Figure, the safety clutch device is set.

### 3) Force applied to the safety clutch

(1) The force applied to the safety clutch is the smallest when the white mark of the eccentric pin faces the center of the lower shaft. The force proportionally increases as the white mark faces the outside.

(2) To adjust the force slide the timing belt, loosen the set screw, and turn the eccentric pin.

(3) After the adjustment, make sure to fasten the set screw.

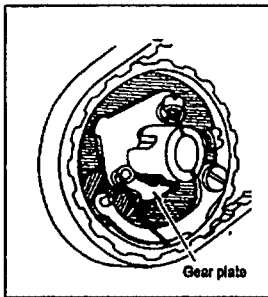

Fig.17

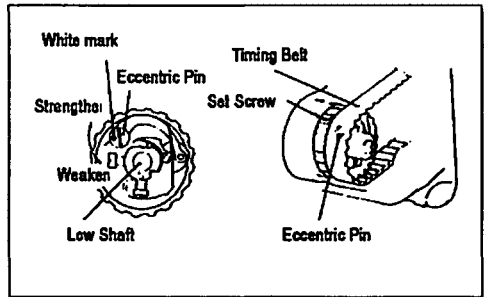

Fig.18

## 16. Adjustment of the height of the feed dog ( Fig.19):

The max. height of the feed dog 1 from the surface to the needle plate 2 is normally 1mm. To adjust this height:

1) Lay down the machine head toward the other side, and turn the pulley so as to raise the feed dog to its highest position;

2) Loosen bell crank screw and adjust the height of the feed dog by raising or lowering it.

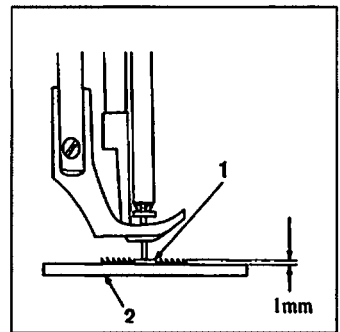

Fig.19

3) Tighten the screw after adjustment.

## 17. Relative position of the feed dog to needle plate (Fig. 20) :

1) Set the stitch length at minimum.

2) Turn the pulley so as to raise the feed dog to its highest point.

3) Lay down the machine head toward the other side, loosen the screw (E);

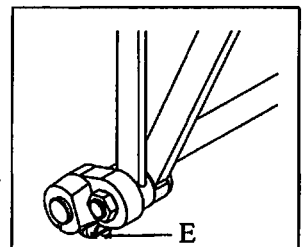

Fig.20

4) Adjust the needle plate to the center of the needle hole on the feed dog.

5) Tighten the screw.

## 18. Adjustment of the height of the needle bar (Fig.21):

When the needle bar is at its highest position, normally the measurement between the surface of the needle plate and the upper end of the needle eye is 22.3mm. You can adjust this at its lowest position. In this case, normally the measurement between the surface of the needle plate and the upper end of the needle eye is 11mm. To adjust this, loosen screw (B.fig.3), and raise or lower the needle bars may be required. Then tighten the screw.

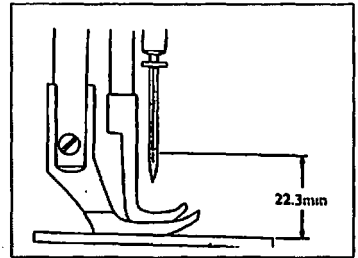

Fig.21

## 19. Adjustment of feed timing (Fig.22):

1) The standard position of the eccentric feed cam and eccentric feed lifting cam are illustrated to Fig.22

2) Open the top cover, properly slide the eccentric ring to adjust the position.

(3) The eccentric feed cam can also be adjusted by removing the rubber plug located on the top cover. In the latter case, however, the built-in bevel gear is when adjusting.

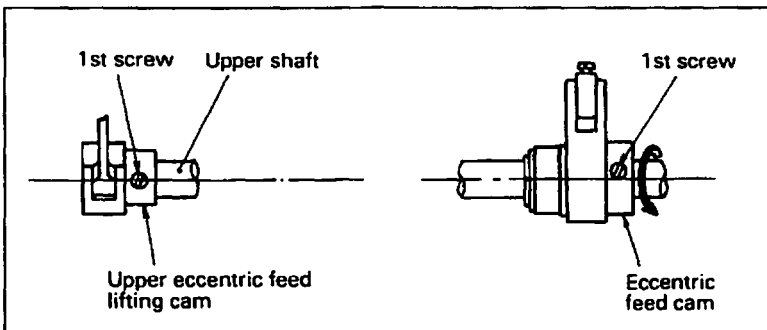
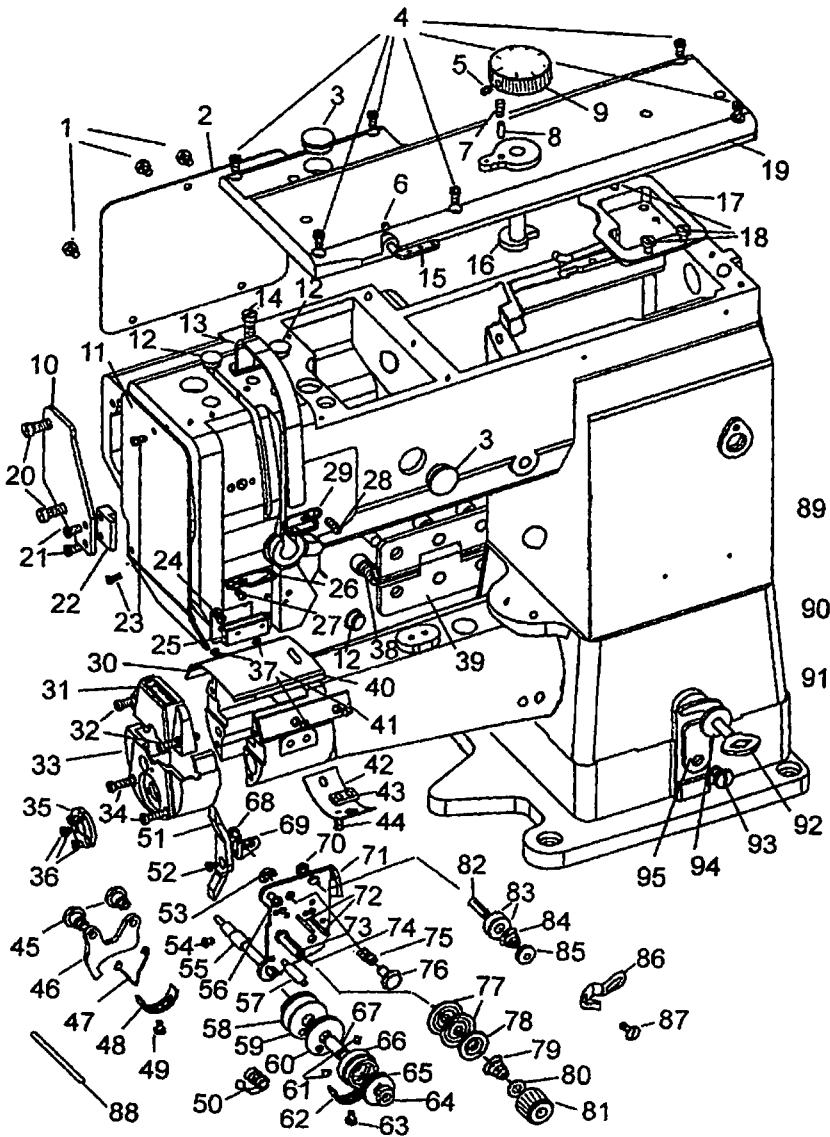

Fig.22

# A. ARM BED AND IT'S ACCESSORIES



## A. ARM BED AND IT' S ACCESSORIES

No.	Ref. No.	Description	Pcs.
A01	H5301001	Screw	3
A02	H5301002	Arm side cover	1
A03	H5301003	Rubber plug	2
A04	H5301004	Screw	6
A05	H5301005	Set screw	2
A06	H5301006	Screw	1
A07	H5301007	Spring	1
A08	H5301008	Pin	1
A09	H5301009	Dial for upper feed lifting	1
A10	H5301010	Oil guard	1
A11	H5301011	Face plate	1
A12	H5301012	Rubber plug	4
A13	H5301013	Thread take-up cover	1
A14	H5301014	Screw	1
A15	H5301015	Three hole thread guide	1
A16	H5301016	Upper feed lifting regulator cam	1
A17	H5301017	Oil box	1
A18	H5301018	Screw	3
A19	H5301019	Top cover	1
A20	H5301020	Screw	2
A21	H5301021	Screw	2
A22	H5301022	Slide block	1
A23	H5301023	Face plate screw	2
A24	H5301024	Screw	1
A25	H5301025	Thread guide	1
A26	H5301026	Thread guide	1
A27	H5301027	Screw	1
A28	H5301028	Screw	1
A29	H5301029	Thread guide	1
A30	H5301030	needle guide plate (right)	1
A31	H5301031	Needle plate	1
A32	H5301032	Set screw	2
A33	H5301033	Stop plate	1
A34	H5301034	Screw	2
A35	H5301035	Bushing	1
A36	H5301036	Screw	3

## A. ARM BED AND IT'S ACCESSORIES

No.	Ref. No.	Description	Pcs.
A37	H5301037	Set screw	4
A38	H5301038	Hinge screw	8
A39	H5301039	Arm bed hinge	1
A40	H5301040	Slide plate	1
A41	H5301041	needle guide plate (left)	1
A42	H5301042	Oil guard plate	1
A43	H5301043	Oil guard plate block	1
A44	H5301044	Screw	1
A45	H5301045	Screw	2
A46	H5301046	Tension releasing plate	1
A47	H5301047	Tension releasing spring	1
A48	H5301048	Stopper	1
A49	H5301049	Screw	1
A50	H5301050	Thread take-up spring	1
A51	H5301051	Lever	1
A52	H5301052	Screw	1
A53	H5301053	Stop ring	1
A54	H5301054	Screw	1
A55	H5301055	Thread tension stud	1
A56	H5301056	Screw	2
A57	H5301057	Screw	1
A58	H5301058	Plate complete	1
A59	H5301059	Plate	1
A60	H5301060	Plate complete	1
A61	H5301061	Screw	2
A62	H5301062	Stopper	1
A63	H5301063	Screw	1
A64	H5301064	Thumb nut	1
A65	H5301065	Take-up spring guard	1
A66	H5301066	Thread tension post	1
A67	H5301067	Bush	1
A68	H5301068	Screw	1
A69	H5301069	Mounting plate	1
A70	H5301070	Nut	2
A71	H5301071	Mounting plate	1
A72	H5301072	Pin	2

## A. ARM BED AND IT'S ACCESSORIES

No.	Ref. No.	Description	Pcs.
A73	H5301073	Thread tension stud	1
A74	H5301074	Pin	1
A75	H5301075	Spring	1
A76	H5301076	Push button	1
A77	H5301077	Thread tension disc	2
A78	H5301078	Thread tension releasing disc	1
A79	H5301079	Spring	1
A80	H5301080	Thumb nut complete	1
A81	H5301081	Thumb nut revolution stopper	1
A82	H5301082	Thread tension stud	1
A83	H5301083	Thread tension disc	2
A84	H5301084	Spring	1
A85	H5301085	Thumb nut	1
A86	H5301086	Thread guide	1
A87	H5301087	Screw	1
A88	H5301088	Thread releasing pin	1
A89	H5301089	Arm	1
A90	H5301090	Arm bed	1
A91	H5301091	Supporter	1
A92	H5301092	Screw	1
A93	H5301093	Screw	1
A94	H5301094	Washer	1
A95	H5301095	Link plate	1



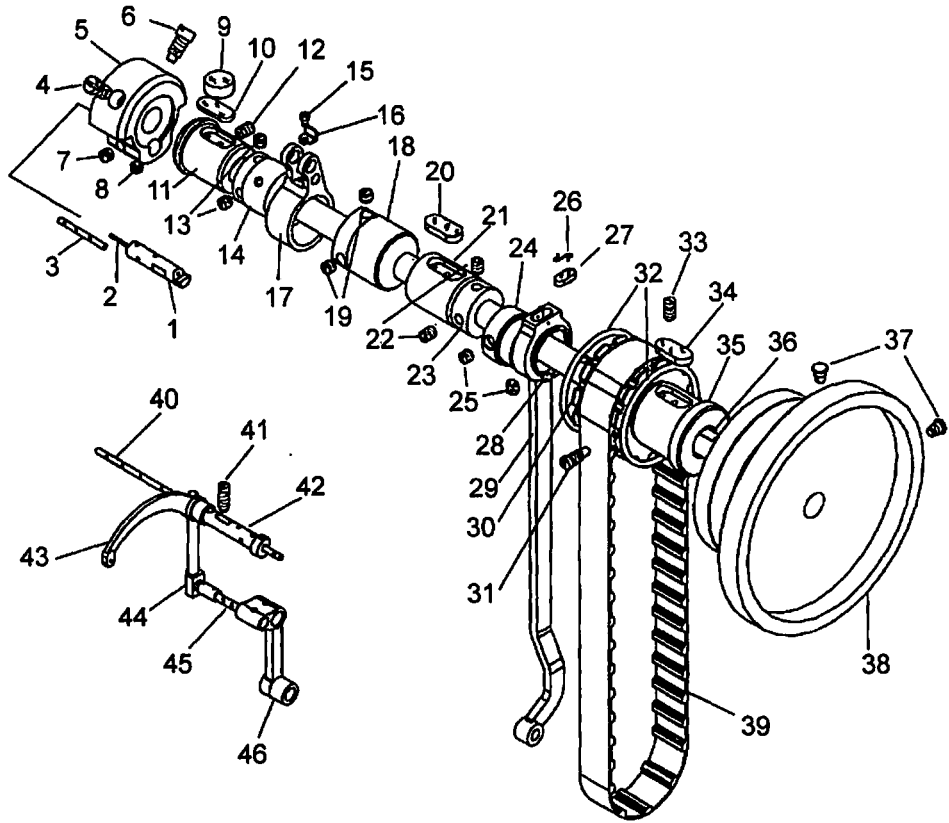

## B. ARM SHAFT MECHANISM

From the library of: Diamond Needle Corp

## B、ARM SHAFT MECHANISM

No.	Ref. No.	Description	Pcs.
B01	H5302001	Pin	1
B03	H5302002	Oil wick	1
B04	H5302003	Screw	1
B05	H5302004	Needle bar crank	1
B06	H5302005	Screw	1
B07	H5302006	Screw	1
B08	H5302007	Screw	1
B09	H5302008	Felt	1
B10	H5302009	Felt	
B11	H5302010	Arm shaft bushing (left)	1
B12	H5302011	Screw	1
B13	H5302012	Screw	2
B14	H5302013	Feed cam (left)	1
B15	H5302014	Screw	1
B16	H5302015	Oil guard plate	1
B17	H5302016	Feed cam crank	1
B18	H5302017	Balance wheel	1
B19	H5302018	Screw	2
B20	H5302019	Felt	1
B21	H5302020	Arm shaft bushing (middle)	1
B22	H5302021	Screw	2
B23	H5302022	Arm shaft collar	1
B24	H5302023	Feed cam (right)	1
B25	H5302024	Screw	2
B26	H5302025	Holder	1
B27	H5302026	Felt	1
B28	H5302027	Stop ring	1
B29	H5302028	Connecting rod for upper feed	1
B30	H5302029	Pulley (upper)	1
B31	H5302030	Screw	1
B32	H5302031	Spring stop ring	2
B33	H5302032	Screw	1
B35	H5302033	Arm shaft bushing (right)	1
B36	H5302034	Arm shaft	1
B37	H5302035	Screw	2
B38	H5302036	Balance wheel	1

## B、 ARM SHAFT MECHANISM

No.	Ref. No.	Description	Pcs.
B39	H5302037	Cog belt	1
B40	H5302038	Oil wick	1
B41	H5302039	Set screw	1
B42	H5302040	Pin	1
B43	H5302041	Thread take-up lever	1
B44	H5302042	Thread take-up link	1
B45	H5302043	Oil wick	1
B46	H5302044	Needle bar connecting link	1

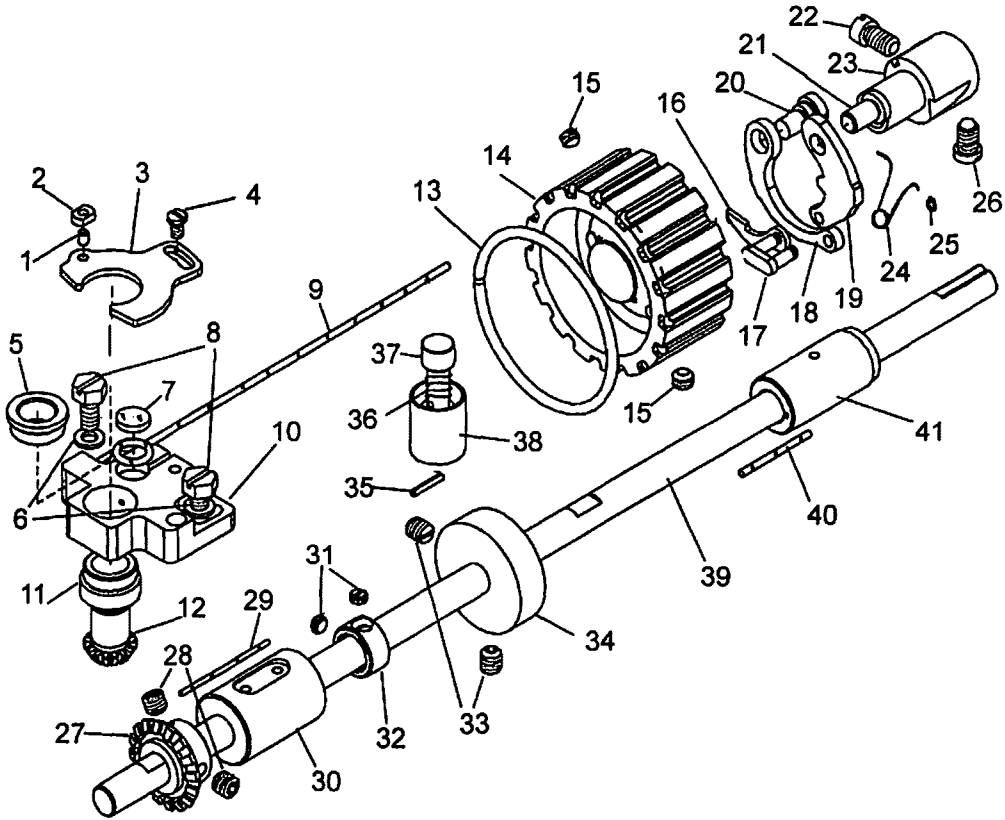

### C. ROTATING HOOK SHAFT MECHANISM

From the library of: Diamond Needle Corp

## C. ROTATING HOOK SHAFT MECHANISM

No.	Ref. No.	Description	Pcs.
C01	H5303001	Guide plate pin	1
C02	H5303002	Guide plate slide block	1
C03	H5303003	Guide plate	1
C04	H5303004	Screw	1
C05	H5303005	Bushing	1
C06	H5303006	Washer	2
C07	H5303007	Felt	1
C08	H5303008	Screw	2
C09	H5303009	Oil wick	1
C10	H5303010	Rotating hook bracket	1
C11	H5303011	Bushing	1
C12	H5303012	Bevel gear for hook shaft	1
C13	H5303013	Stop ring	1
C14	H5303014	Pulley	1
C15	H5303015	Screw	2
C16	H5303016	Lever for pulley	1
C17	H5303017	Pin	1
C18	H5303018	Long lever for pulley	1
C19	H5303019	Short lever for pulley	1
C20	H5303020	Pin	1
C21	H5303021	Pin	1
C22	H5303022	Screw	1
C23	H5303023	Shaft for pulley	1
C24	H5303024	Spring for pulley	1
C25	H5303025	E-type stop ring	1
C26	H5303026	Screw	1
C27	H5303027	Bevel gear for hook shaft	1
C28	H5303028	Set screw	3
C29	H5303029	Oil wick	1
C30	H5303030	Rotating hook shaft bushing (left)	1
C31	H5303031	Screw	2
C32	H5303032	Rotating hook shaft collar	1
C33	H5303033	Set screw	2
C34	H5303034	Recessed wheel	1
C35	H5303035	Safe clutch shaft pin	1
C36	H5303036	Safe clutch spring	1

### C. ROTATING HOOK SHAFT MECHANISM

No.	Ref. No.	Description	Pcs.
C37	H5303037	Safe clutch shaft	1
C38	H5303038	Safe clutch bushing	1
C39	H5303039	Rotating hook shaft	1
C40	H5303040	Oil wick	
C41	H5303041	Rotating hook shaft bushing (right)	1

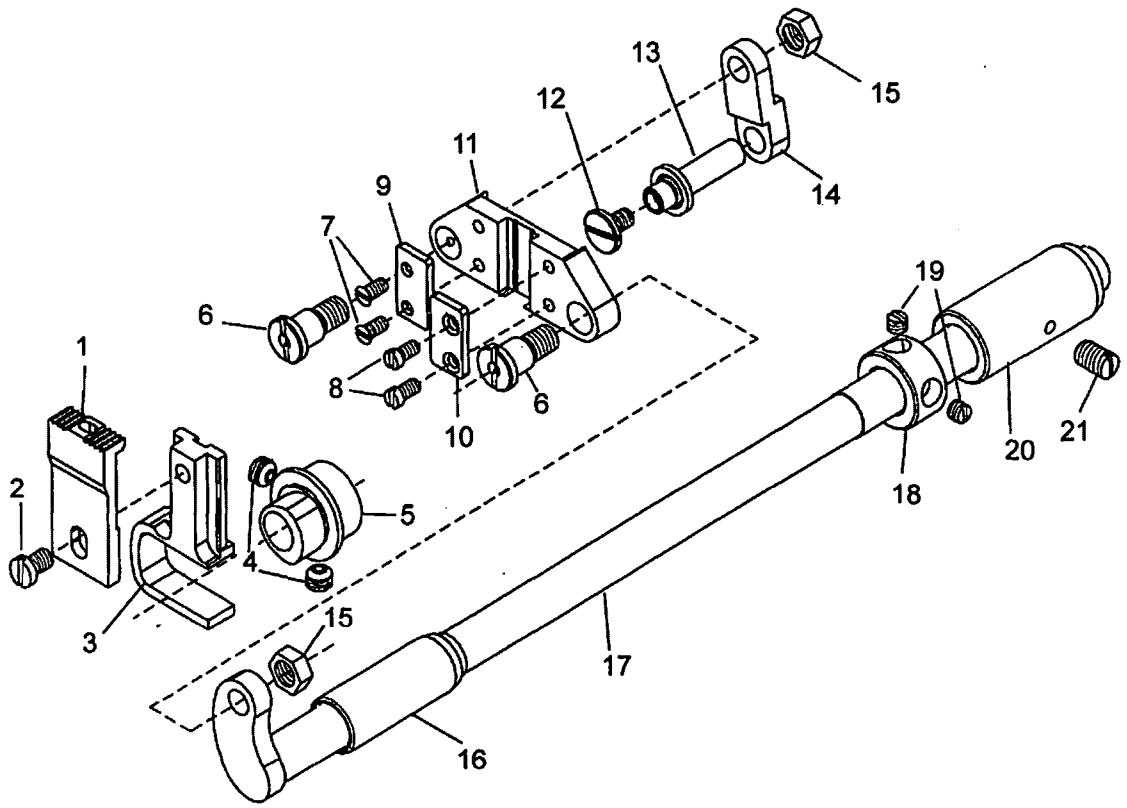

**D. FEED AND FEED LIFTING MECHANISM**

From the library of: [Diamond Needle Corp](#)

## D、 FEED AND FEED LIFTING MECHANISM

No.	Ref. No.	Description	Pcs.
D01	H5304001	Feed dog	1
D02	H5304002	Connecting screw for feed dog	1
D03	H5304003	Feed rock lifting shaft crank	1
D04	H5304004	Set screw	2
D05	H5304005	Feed eccentric	1
D06	H5304006	Screw	2
D07	H5304007	Screw	2
D08	H5304008	Screw	2
D09	H5304009	Guide plate (left)	1
D10	H5304010	Guide plate (right)	1
D11	H5304011	Feed rock shaft crank	1
D12	H5304012	Screw	1
D13	H5304013	Pin	1
D14	H5304014	Link	1
D15	H5304015	Nut	2
D16	H5304016	Feed rock shaft bushing (left)	1
D17	H5304017	Feed rock shaft	1
D18	H5304018	Collar for feed rock shaft	1
D19	H5304019	Set screw	2
D20	H5304020	Feed rock shaft bushing (right)	1
D21	H5304021	Set screw	2



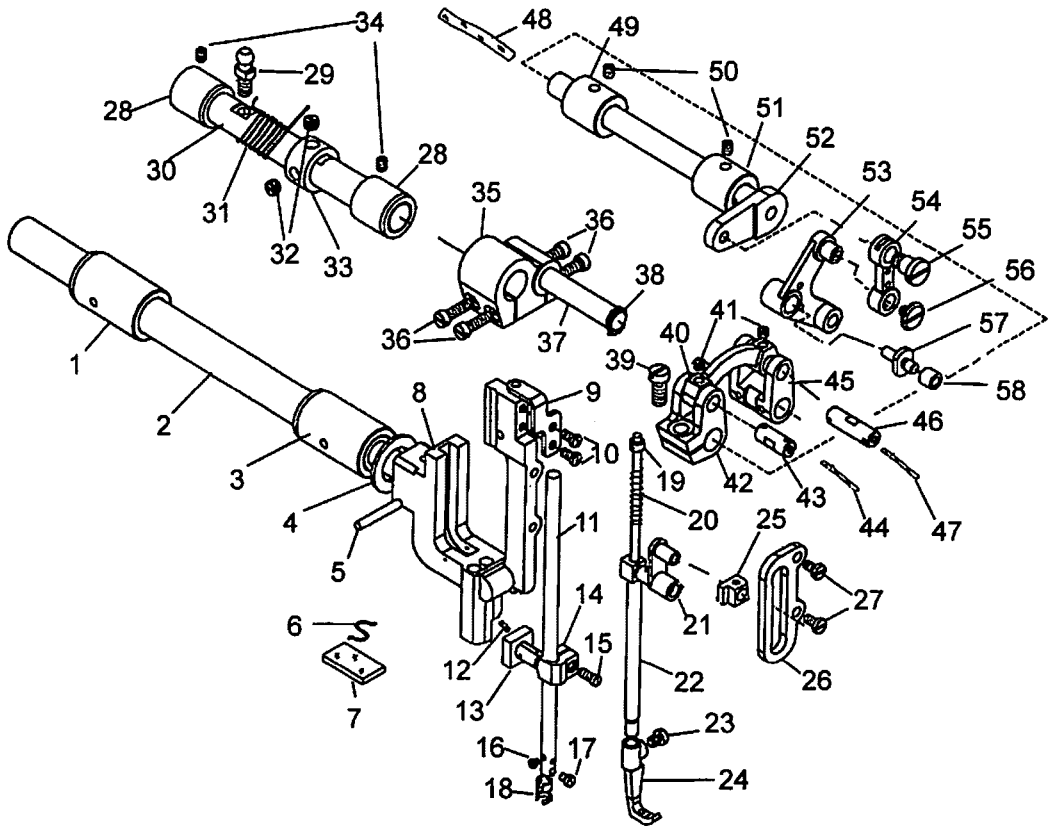

## E. NEEDLE BAR FEEDING MECHANISM

No.	Ref. No.	Description	Pcs.
E01	H5305001	Needle bar rock shaft bushing (right)	1
E02	H5305002	Needle bar rock shaft	1
E03	H5305003	Needle bar rock shaft bushing (left)	1
E04	H5305004	Washer	1
E05	H5305005	Pin	1
E06	H5305006	Felt clip	1
E07	H5305007	Felt	1
E08	H5305008	Needle bar rock frame	1
E09	H5305009	Bracket	1
E10	H5305010	Screw	2
E11	H5305011	Needle bar	1
E12	H5305012	Oil wick	1
E13	H5305013	Slide block	1
E14	H5305014	Needle bar connecting stud	1
E15	H5305015	Screw	1
E16	H5305016	Screw	1
E17	H5305017	Screw	1
E18	H5305018	Thread guide for needle bar	1
E19	H5305019	Spring guide bar complete	1
E20	H5305020	Spring	1
E21	H5305021	Presser bar connecting link	1
E22	H5305022	Presser bar	1
E23	H5305023	Screw	1
E24	H5305024	Presser foot	1
E25	H5305025	Slide block	1
E26	H5305026	Guide for slide block	1
E27	H5305027	Screw	2
E28	H5305028	Bushing for upper feed shaft	2
E29	H5305029	Cam follower	1
E30	H5305030	Upper feed regulator shaft	1
E31	H5305031	Spring	1
E32	H5305032	Set screw	2
E33	H5305033	Collar	1
E34	H5305034	Set screw	2
E35	H5305035	Lifting rock shaft bracket	1
E36	H5305036	Screw	4

## E、 NEEDLE BAR FEEDING MECHANISM

No.	Ref. No.	Description	Pcs.
E37	H5305037	Shaft for Lifting rock shaft bracket	1
E38	H5305038	Stop ring	1
E39	H5305039	Screw	1
E40	H5305040	Link	1
E41	H5305041	Set screw	2
E42	H5305042		1
E43	H5305043	Pin	1
E44	H5305044	Oil wick	1
E45	H5305045	Crank for lifting rock shaft bracket	1
E46	H5305046	Pin	1
E47	H5305047	Oil wick	1
E48	H5305048	Oil wick	1
E49	H5305049	Bushing for lifting rock shaft (right)	1
E50	H5305050	Set screw	2
E51	H5305051	Bushing for lifting rock shaft (left)	1
E52	H5305052	Lifting rock shaft	1
E53	H5305053	Bell crank	1
E54	H5305054	Link for feed lifting rock shaft	1
E55	H5305055	Screw	1
E56	H5305056	Screw	1
E57	H5305057	Bell crank guide pin	
E58	H5305058	Bell crank guide bracket block	

## F. PRESSER FOOT MECHANISM

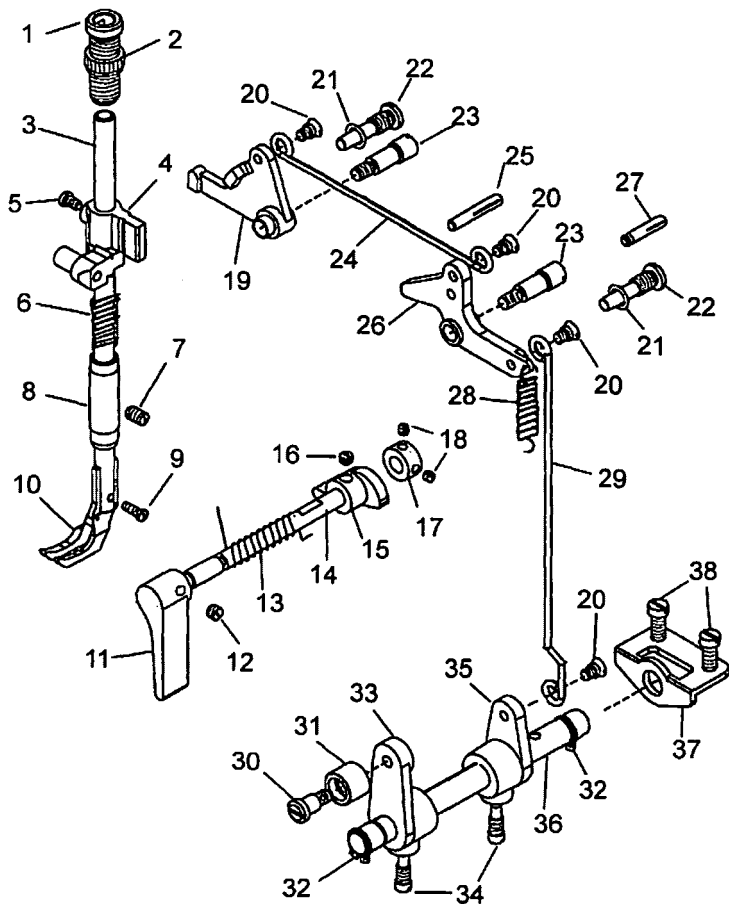

## F、PRESSER FOOT MECHANISM

No.	Ref. No.	Description	Pcs.
F01	H5306001	Nut	1
F02	H5306002	Thumb screw	1
F03	H5306003	Presser bar	1
F04	H5306004	Presser bar guide bracket	1
F05	H5306005	Screw	1
F06	H5306006	Presser bar spring	1
F07	H5306007	Set screw	1
F08	H5306008	Bushing for presser bar	1
F09	H5306009	Screw	1
F10	H5306010	Walking foot	1
F11	H5306011	Presser bar lifter	1
F12	H5306012	Set screw	1
F13	H5306013	Spring	1
F14	H5306014	Presser bar lifting shaft	1
F15	H5306015	Presser bar lifting cam	1
F16	H5306016	Set screw	1
F17	H5306017	Collar	1
F18	H5306018	Set screw	2
F19	H5306019	Tension releasing cam	1
F20	H5306020	Screw	4
F21	H5306021	Seal	2
F22	H5306022	Screw	3
F23	H5306023	Screw	2
F24	H5306024	Knee lifter rod	1
F25	H5306025	Pin	1
F26	H5306026	Knee lifter lever	1
F27	H5306027	Pin	1
F28	H5306028	Spring	1
F29	H5306029	Knee lifter connecting rod	1
F30	H5306030	Screw	1
F31	H5306031	Guide block	1
F32	H5306032	Stop ring	2
F33	H5306033	Knee lifter connecting rod shaft crank	1
F34	H5306034	Screw	2
F35	H5306035	Knee lifter connecting rod shaft crank	1
F36	H5306036	Knee lifter connecting rod shaft	1

## F、PRESSER FOOT MECHANISM

No.	Ref. No.	Description	Pcs.
F37	H5306037	Mounting plate	1
F38	H5306038	Screw	2

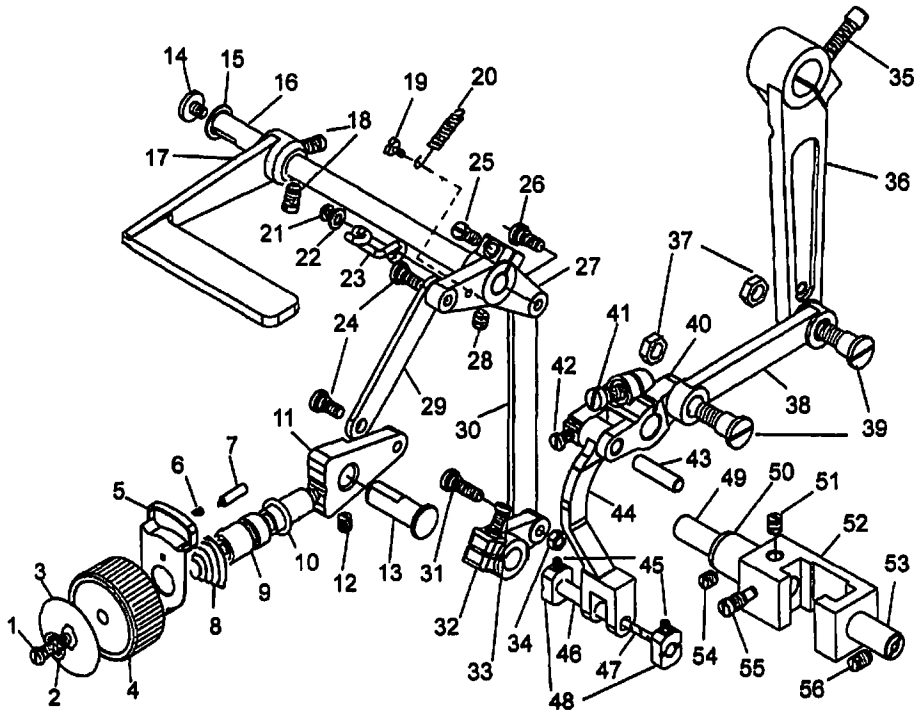

**G. STITCH LENGTH REGULATING MECHANISM**

From the library of: Diamond Needle Corp

## G. STITCH LENGTH REGULATING MECHANISM

No.	Ref. No.	Description	Pcs.
G01	H5307001	Screw	1
G02	H5307002	Bushing	1
G03	H5307003	Plate for stitch length	1
G04	H5307004	Dial	1
G05	H5307005	Stopper pin releasing lever	1
G06	H5307006	Spring for stopper pin	1
G07	H5307007	Stopper pin	1
G08	H5307008	Coil spring	1
G09	H5307009	Screw bar	1
G10	H5307010	Seal	1
G11	H5307011	Feed regulator crank	1
G12	H5307012	Set screw	1
G13	H5307013	Pin	1
G14	H5307014	Screw	1
G15	H5307015	Washer	1
G16	H5307016	Feed reversing lever shaft	1
G17	H5307017	Feed reversing lever	1
G18	H5307018	Set screw	2
G19	H5307019	Screw	1
G20	H5307020	Spring	1
G21	H5307021	Screw	1
G22	H5307022	Washer	1
G23	H5307023	Spring retainer	1
G24	H5307024	Screw	2
G25	H5307025	Screw	1
G26	H5307026	Screw	1
G27	H5307027	Feed reversing lever shaft crank	1
G28	H5307028	Set screw	1
G29	H5307029	Feed reversing lever shaft link	1
G30	H5307030	Link for reversing block shaft crank	1
G31	H5307031	Screw	1
G32	H5307032	Reverse block shaft crank	1
G33	H5307033	Screw	1
G34	H5307034	Nut	1
G35	H5307035	Screw	1
G36	H5307036	Link	1



## G、 STITCH LENGTH REGULATING MECHANISM

No.	Ref. No.	Description	Pcs.
G37	H5307037	Nut	2
G38	H5307038	Link	1
G39	H5307039	Screw	2
G40	H5307040	Crank	1
G41	H5307041	Screw	1
G42	H5307042	Screw	1
G43	H5307043	Crank shaft	1
G44	H5307044	Link for reversing block slide block	1
G45	H5307045	Set screw	2
G46	H5307046	Shaft for reversing block slide block	1
G47	H5307047	Oil wick	1
G48	H5307048	Slide block	2
G49	H5307049	Reverse block shaft	1
G50	H5307050	Bushing for reverse block shaft	1
G51	H5307051	Set screw	1
G52	H5307052	Reverse block	1
G53	H5307053	Reverse block shaft	1
G54	H5307054	Set screw	1
G55	H5307055	Screw	1
G56	H5307056	Set screw	1

## H. ACCESSORIES

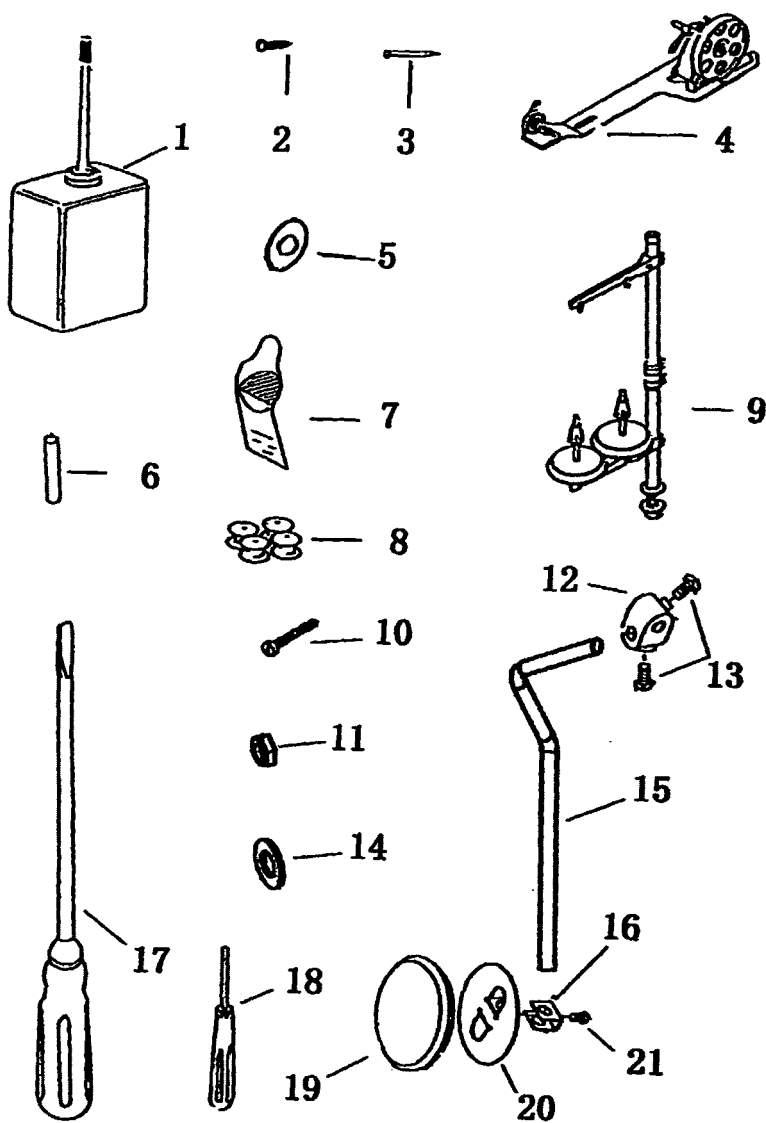

## H. ACCESSORIES

No.	Ref. No.	Description	Pcs.
H01	H5308001	Oiler	1
H02	H5308002	Wood screw	4
H03	H5308003	Nail	15
H04	H5308004	Bobbin winder assay	1
H05	H5308005	Washer	2
H06	H5308006	Supporter	1
H07	H5308007	Needle	1
H08	H5308008	Bobbin	1
H09	H5308009	Thread stand assay	1
H10	H5308010	Screw	4
H11	H5308011	Nut	4
H12	H5308012	Knee lifter driving crank	1
H13	H5308013	Screw	2
H14	H5308014	Washer	4
H15	H5308015	Knee lifter shaft	1
H16	H5308016	Knee lifter bracket	1
H17	H5308017	Screw driver (larger)	1
H18	H5308018	Screw driver (middle)	1
H19	H5308019	Knee lifter cover	1
H20	H5308020	Knee lifter plate	1
H21	H5308021	Screw	1

---

**SHANGHAI HUIGONG SEWING MACHINE NO.3 FACTORY**

**ADD: 1418, Yishan Road, Shanghai, China**

**Zip Code: 201103**

**TEL: (021)64061284 64852138**

**FAX: (021)64853208**

---