



**HIGHLEAD**

**GC20698-5/-6/-7/-8**

**Compound-Feed, Heavy Duty  
Lockstitch Sewing Machine**

**Instruction Manual  
Parts Catalog**



# —INDEX—

## OPERATION INSTRUCTION

1. PRECAUTIONS BEFORE STARTING OPERATION .....	1
2. SPECIFICATIONS .....	1
3. SETTING UP THE MACHINE.....	2
4. OILING.....	2
5. NEEDLE.....	3
6. THREAD.....	4
7. WINDING THE LOWER THREAD ON THE BOBBIN.....	4
8. REMOVE AND INSERT THE BOBBIN.....	4
9. THREADING THE NEEDLE.....	5
10. REGULATING THE THREAD TENSION.....	5
11. ADJUSTMENT OF THE STITCH LENGTH.....	6
12. ADJUSTMENT OF THE PREESURE .....	6
13. REVERSE STITCH.....	6
14. WIDTH OF ZIGZAG AND LENGTH OF STITCH.....	7
15. ADJUSTMENT THE HEIGHT OF THE FEED DOG.....	7
16. TIMING BETWEEN THE HOOK AND THE NEEDLE.....	8
17. ADJUSTMENT OF BOBBIN CASE OPENER.....	9
18. THE HEIGHT OF THE PRESSER FEET .....	9
19. TIMING OF THE VIBRATING AND LIFTING PRESSER FEET.....	10
20. THE CLEARANCE OF THE VIBRATING AND LIFTING PRESSER FEET.....	10
21. ADJUSTMENT OF THE THREAD CONTROLLER SPRING.....	11
22. REPLACEMENT OF THE CONNECTION BELT.....	11
23. TO RE-ENGAGE THE SAFETY CLUTCH.....	12
24. ADJUSTMENT OF THE OILING FOR THE HOOK SADDLE.....	13

## PARTS CATALOG

A. ARM BED AND IT'S ACCESSORIES.....	14
B. ARM SHAFT MECHANISM.....	17
C. PRESSER FOOT MACHANISM.....	20

D. STITCH REGULATOR MACHANISM.....	23
E. HOOK SHAFT MECHANISM.....	26
F. THREAD TENSION REGULATOR MACHANISM.....	29
G. PARTS FOR SINGEL NEEDLE.....	32
H. PARTS FOR TWIN NEEDLE.....	34
I. SPECIAL PARTS FOR 20".....	35
J. ACCESSORIES.....	37



# 1. PRECAUTIONS BEFORE STARTING OPERATION

## 1) Safety precautions

(1) When turning the power on, keep your hands and fingers away from the area around/under the needle and the area around the pulley.

(2) Power must be turned off when the machine is not in use, or when the operator leaves the seat.

(3) Power must be turned off when tilting the machine head, installing or removing the "V" belt, adjusting the machine, or when replacing.

(4) Avoid placing fingers, hairs, bars etc., near the pulley, "V" belt, bobbin winder pulley, or motor when the machine is in operation.

(5) Do not insert fingers into the thread take-up cover, under/around the needle, or pulley when the machine is in operation.

(6) If a belt cover, finger guard, eye guard are installed, do not operate the machine without these safety devices.

## 2) Precautions before starting operation

(1) If the machine's oil pan has an oil sump, never operate the machine before filling it.

(2) If the machine is lubricated by a drop oiler, never operate the machine before lubricating.

(3) When a new sewing machine is first turned on, verify the rotational direction of the pulley with the power on. (The pulley should rotate counterclockwise when viewed from the pulley).

(4) Verify the voltage and (single or three) phase with those given on the machine nameplate.

## 3) Precautions for operating conditions

(1) Avoid using the machine at abnormally high temperatures (35°C or higher) or low temperatures (5°C or lower) .

(2) Avoid using the machine in dusty conditions.

# 2. SPECIFICATIONS

	GC20698-5	GC20698-6	GC20698-7	GC20698-8
MAX. SPEED (s. p. m.)	1,200			
MAX. STITCH (mm)	10			
MAX. LIFT OF FOOT (mm)	20			
NEEDLE	DY × 3 (standard No. 24) • SY5213 • 794			
BOBBIN SIZE (mm)	Φ37 × 13			
WORKING SPACE (mm)	508 × 153		762 × 153	
BED DIMENSION (mm)	846 × 230		1,100 × 230	
NEEDLE SPACING	—	3/4" (19mm) (standard) 1/4" (6.4 mm) ~ 1-3/4" (44.5mm)	—	3/4" (19mm) (standard) 1/4" (6.4 mm) ~ 1-3/4" (44.5mm)

**USE FOR:** Tent, Sailcloth, Rubberized, Fabrics, Heavy Synthetic, Heavy Upholstery Materials, Fiber Plate, Leather, Etc.

### 3. SETTING UP THE MACHINE (Fig. 1)

Setting up the machine on the table after removed two pieces of supporting bolts (A) under the bed.

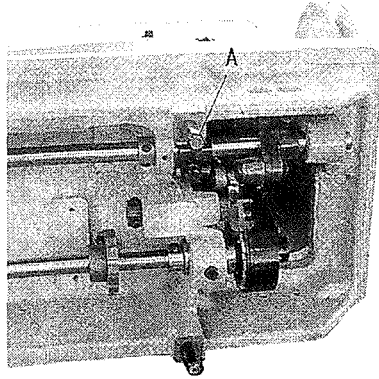

Fig.1

### 4. OILING (Figs. 2, 3, 4 & 5)

Oil should be applied at each of the place designated by arrows in Figs. 2, 3, 4 & 5.

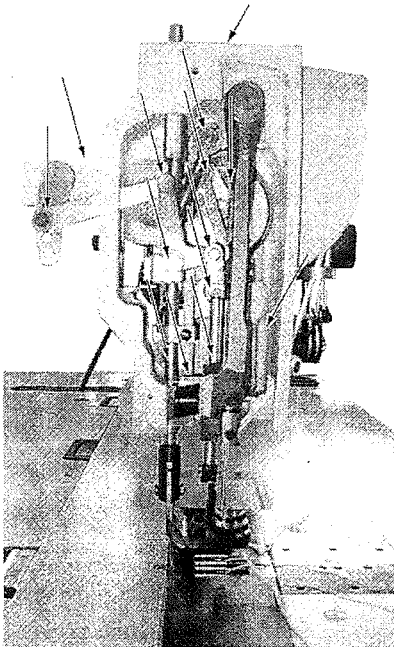

Fig.2

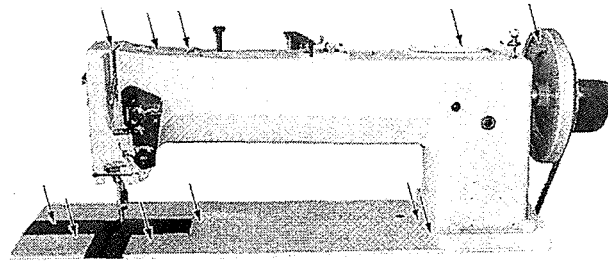

Fig.3

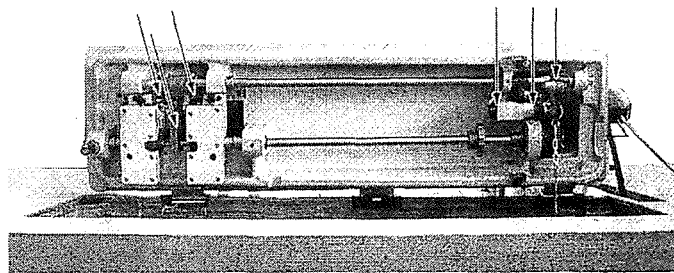

Fig.4

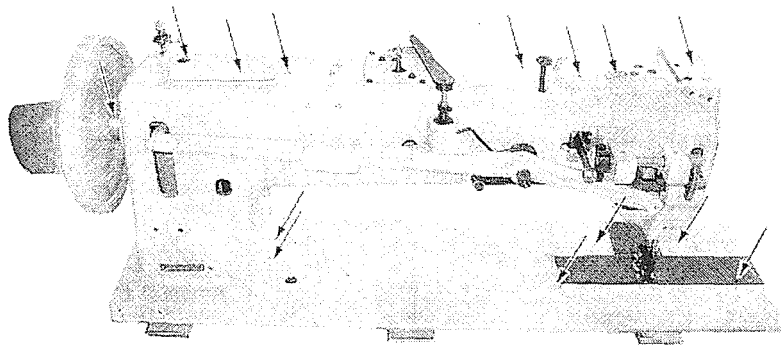

Fig.5

To fill the oil for reservoir of hook saddle from the hole after taken out the oil gauge A (Fig. 6) and pour the oil until the oil level reached to the upper reference line B of the oil gauge (Fig. 6-1) .

When in continuous use, it should be oiled at least twice a day.

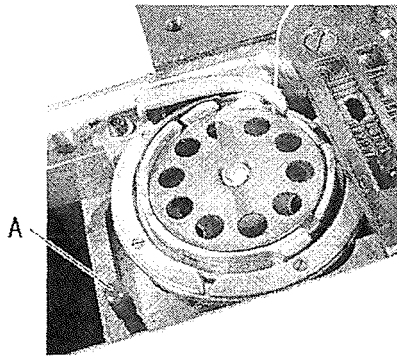

Fig.6

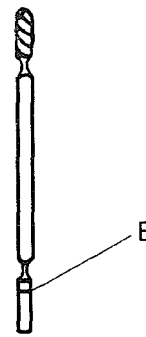

Fig.6-1

## 5. NEEDLE ( Figs. 7 & 8 )

HIGHLEAD GC20698-5,-6,-7,-8 series machines are set up to use standard needle of DY×3 (standard No. 24) ·SY5213·794. The size of needle to be used should be determined by the size of thread, type and thickness of the sewing materials.

To insert the needle, turn the machine pulley over toward you until the needle bar moves up to its highest point, put the needle up into the needle bar as deeply as it will go, with the long groove of the needle faced outside.

Tighten the needle set screw securely.

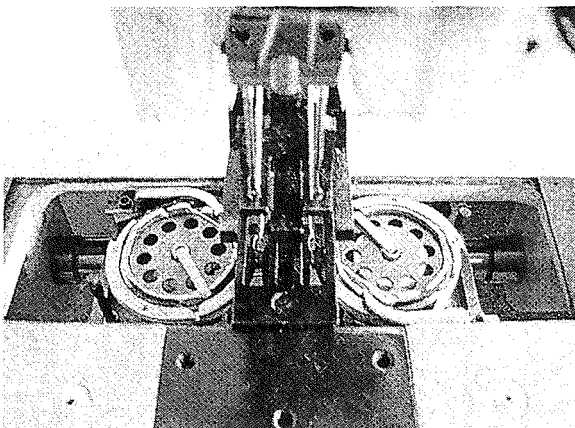

Fig.7

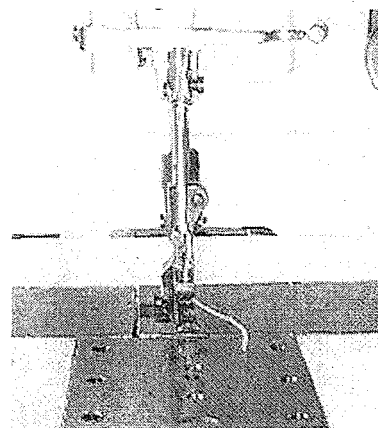

Fig.8

## 6. THREAD (Fig. 9)

Normally, left twisted thread is used for upper (needle) thread. (But, for left side needle of of twin-needle machine, it can be finished in fine results with right twisted thread) .

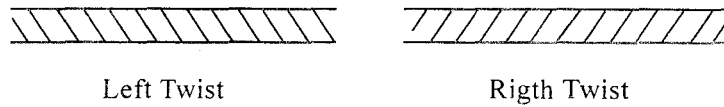

Fig.9

## 7. WINDING THE LOWER THREAD ON THE BOBBIN (Figs. 10 & 11)

Pass the thread through (1) - (4) , and wind several times around the bobbin, which set up to the shaft of bobbin winder.

Press the lever (5) to arrow direction, then the bobbin winds the thread automatically, in engage with the operation of the machine.

The bobbin will automatically be stopped after the bobbin is filled with thread.

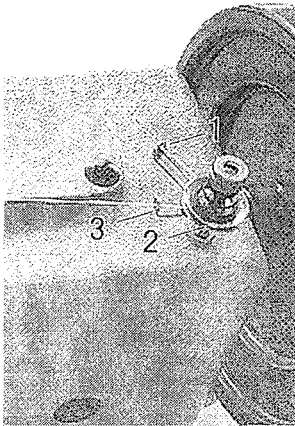

Fig.10

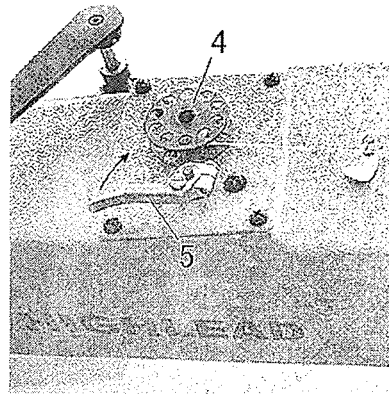

Fig.11

## 8. REMOVING AND INSERTING THE BOBBIN (Figs. 12 & 13)

Draw back the side plate (1) on the bed of the machine, and raise the hinged latch (2) to a vertical position, then remove and insert the bobbin.

Insert the bobbin and pull thread (3) out about 4-5cm, then push down the hinged latch (2) and draw the thread end under the tension spring (4) .

When closing the side plate (1) , leave just enough space for the thread to pass through.

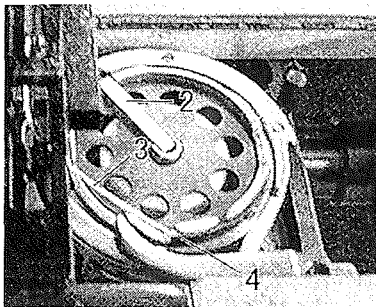

Fig.12

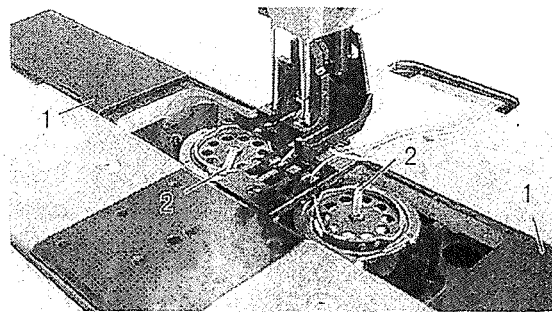

Fig.13



## 9. THREADING THE NEEDLE ( Figs. 14 & 15 )

Pass the thread from thread guide (1) -eyelet (2) -tension disc (3) -tension thread guide (4) -guide (5) -thread take-up spring (6) -guide (7) -take-up lever (8) -guide (7) -lower guide (9) -self threading needle bar thread guide (10) -through the eye of the needle (11) .(Remark) Wind the thread a single time to tension thread guide (4) .

With the left hand hold the end of the needle thread leaving it slack from the hand to the needle. Turn the machine pulley over toward you until the needle moves down and up again to its highest point, thus catching the bobbin thread, draw up the needle thread, and the bobbin thread will come up with it through the hole in the feed dog.

Lay the thread back under the presser feet and close the slide.

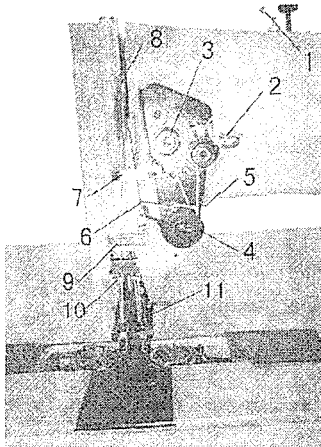

Fig. 14

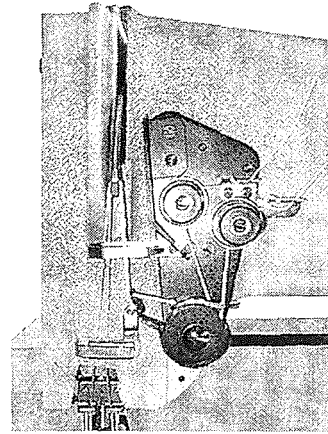

Fig. 15

## 10. REGULATING THE THREAD TENSION ( Figs. 16 & 17 )

The tension on the needle thread is regulated by the thumb nut A ( Fig. 16 ) .

The tension on the bobbin thread is regulated by the screw of the tension spring on the outside of the bobbin case B ( Fig. 17 ) .

To increase the tension, turn over nut A or screw to the right, and to decrease the tension, turn over nut or screw to the left.

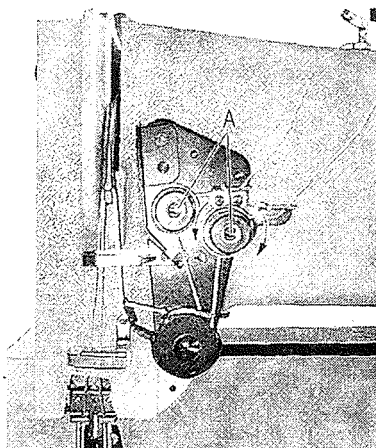

Fig. 16

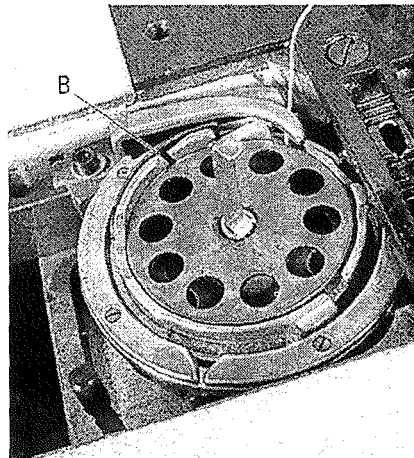

Fig. 17

## 11. ADJUSTMENT OF THE STITCH LENGTH (Fig. 18)

The length of stitch is regulated by pressing down the button (1) with left hand, while turning the machine pulley (2) slowly with right hand in the condition of setting the top of button (1) to the feed eccentric.

To increase the length of stitch, turn the machine pulley over toward you.

To decrease the length of stitch, turn the machine pulley to opposite direction.

When the desired length of stitch is obtained, operate the machine after fully confirmed releasing the button (1) to the original position.

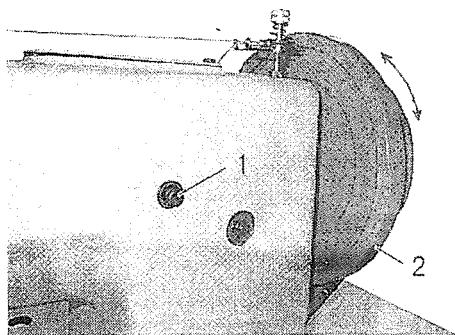

Fig.18

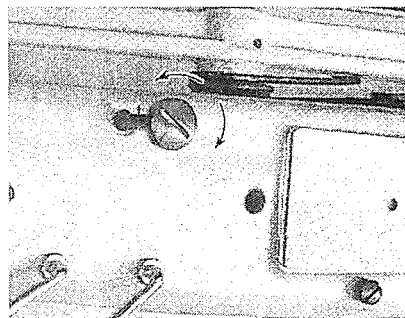

Fig.19

## 12. ADJUSTMENT OF THE PRESSURE (Fig. 19)

The pressure of the presser feet is regulated by the adjusting screw.

To increase the pressure, turn the screw to clockwise, and decrease it, turn the screw to counter-clockwise.

## 13. REVERSE STITCHING (Fig. 20)

The chain for the feed reversing pedal is connected to the hook of feed reversing lever A underneath of the bed of the machine.

To feed the work toward you, press down firmly on the feed reversing pedal, and do not stop to press down on the way.

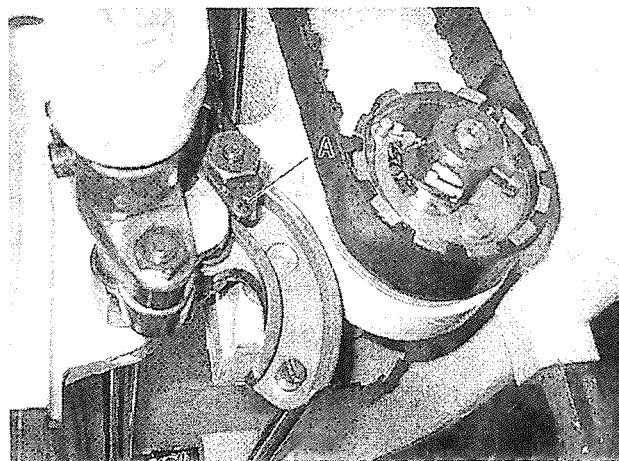

Fig.20

## 14. RELATIVE POSITION OF VIBRATING AND LIFTING PRESSER BAR, OF THE NEEDLE AND THE NEEDLE HOLE OF THE FEEDER ( Figs. 21 & 22 )

The distance between the vibrating presser bar (1) and lifting presser bar(2), after adjusting the feed eccentric so that there is no feed movement of the needle bar, should be 15.5 mm (one needle) and 14.5 mm (two needle) .To adjust by the screws for connecting crank (3).

Normally, relative position of the feed dog against the needle, the needle should be passed through the center of the needle hole of the feed dog .

To adjust by the screw for the feed rock shaft bell crank(4).

Securely tighten the screws after finished adjustment.

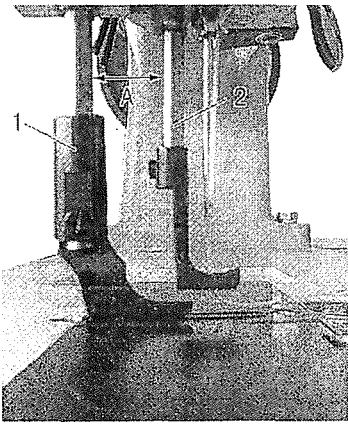

Fig.21

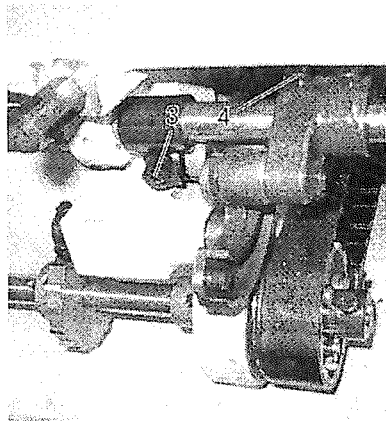

Fig.22

## 15. ADJUSTMENT THE HEIGHT OF THE FEED DOG ( Figs. 23,24 & 25 )

The maximum height of the feed dog from the surface of the needle plate is normally 1.3 mm.

To adjust this height by the screw on the feed lifting cam fork of the feed bar and raise or lower the feed dog, as may be required, and retighten the screw (1) .

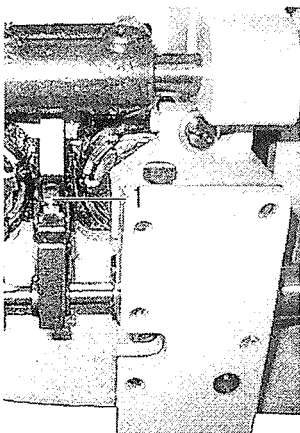

Fig.23

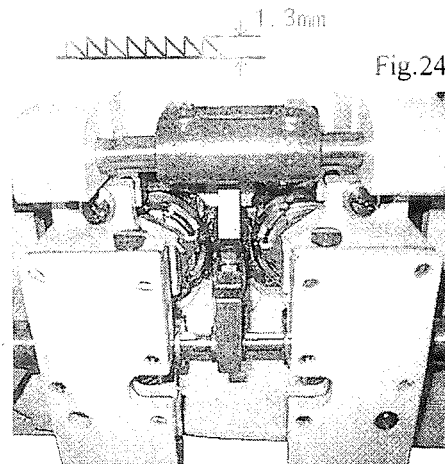

Fig.25

## 16. TIMING BETWEEN THE HOOK AND THE NEEDLE (Fig. 26)

Set the feed eccentric with the button at no feeding position, and confirm the length between vibrating and lifting presser bar should be 15.5 mm.

If the needle bar and sewing hook are correctly timed, the point of the hook will be at the center of the needle when the needle raised 3.8 mm + 0.5 mm from the lowest point.

### 1) Adjustment of the timing

(1) For the adjustment of timing, loosen 2 screws (1) for hook driving gear, and tap this gear to the right or left in clearance of 2 mm on the hook driving shaft until the point of the hook is at the center of the needle.

(2) Tapping to the right gives on earlier hook timing, and to the left gives later hook timing.

(3) Except the above case, to adjust in changing gear condition between hook driving gear (2) and hook shaft gear (3) .

(4) Securely tighten the two set screws for hook driving gear after finished adjustment

### 2) Adjustment of the clearance

Normal clearance between hook point and scarf of the needle is in 0.02 - 0.1 mm

(1) Loosen two screws (4) and (5) for hook saddle.

(2) Move hook saddle to right or left, as may be required, until hook point is as close to needle as possible without striking it.

(3) Then securely tighten two screws.

(4) To check the needle with careful attention free from bent before adjustment.

### 3) Height of the needle bar (Fig. 27)

Normal clearance between top of the eye of the needle and hook point is 2.2 mm .

In case the needle bar is incorrectly set, loose the needle bar connecting stud pinch screw (A) and place the needle bar in correct position as required above, then retighten the screw (A) .

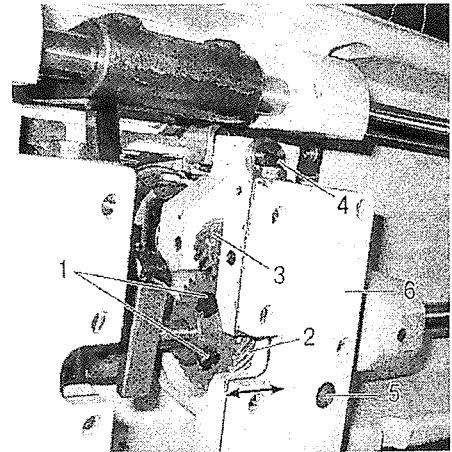

Fig.26

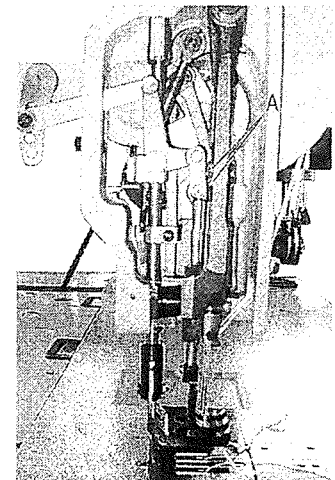
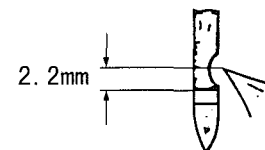

Fig.27



## 17. ADJUSTMENT OF BOBBIN CASE OPENER (Fig. 28)

(1) Turn the machine pulley or hand wheel (GC20698-6,-8 series machine) until the top of the opener is located at the distance from the needle plate.

(2) In this position, adjust it so that the clearance A between the inside edge of the opener and the top of the hook is about 0.3 - 0.8 mm.

(3) Securely tighten the screw B after finished adjustment.

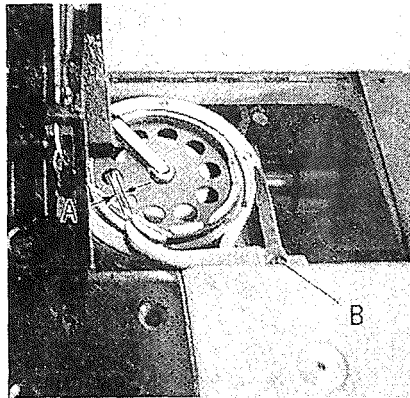

Fig.28

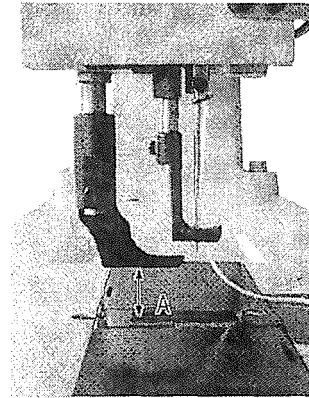

Fig.29

## 18. THE HEIGHT OF THE PRESSER FEET (Figs. 29,30 & 31)

Normal distance between the surface of the needle plate (A) and vibrating presser foot at stopped position of the stop lever (C) is 19 mm.

When step on the lifting pedal, the stop lever (C) will be released by the lifting lever (B).

To change the relative lift of the presser feet, loosen the screw (1) at the above condition.

The height of lift of the presser feet is adjustable by moving the screw of presser bar lifting bracket.

Normal distance between presser bar position guide bracket (3) and presser bar position guide (4) is 7 mm.

Position of the vibrating presser foot to shift in left and right is to be adjusted by the screw (2) for presser bar lifting bracket and the screw (5) for presser bar position guide bracket.

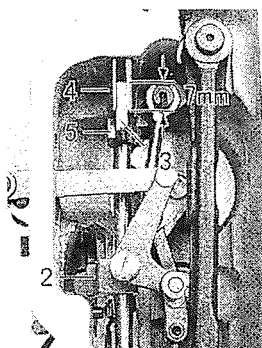

Fig.30

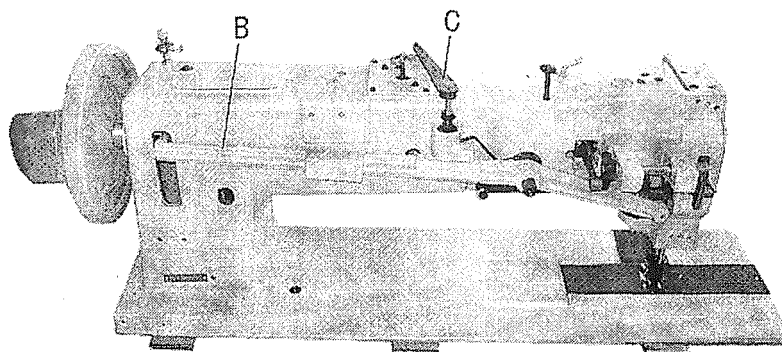

Fig.31

## 19. TIMING OF THE VIBRATING AND LIFTING PRESSER FEET (Fig. 32)

The amount of lift of the vibrating and lifting presser feet should be regulated according to the thickness of materials being sewn.

The feet should lift just enough to clear the materials.

As a rule, the vibrating and lifting presser feet should lift an equal height, but some grades of work may require that they lift an unequal height.

To change the relative lift of the presser feet, loosen the screw (A) for lifting rock shaft crank and move the vibrating presser bar upward or downward as required, then securely tighten the screw (A).

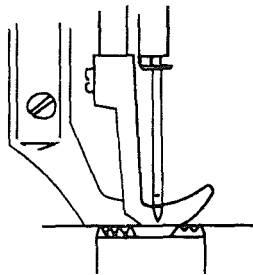

Upper Surface

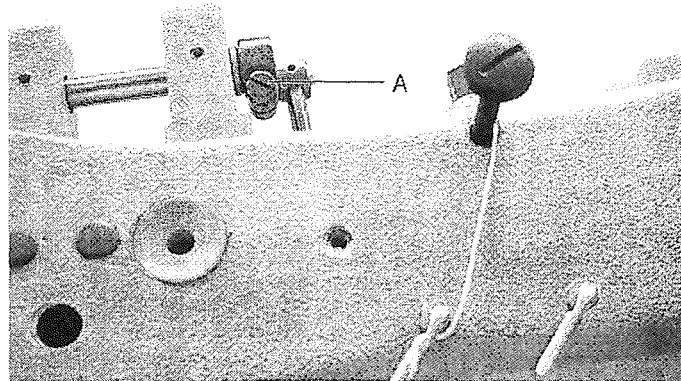

Fig.32

## 20. THE CLEARANCE OF THE VIBRATING AND LIFTING PRESSER

### FEET (Fig. 33)

The amount of the lift of the alternating feed for the vibrating and lifting presser feet are to be adjusted by the lifting bell crank link screw stud (1).

To decrease the movement in setting the stud (1) at the upper position, and to increase the movement in setting the stud (1) at the lower position. After setting to the required position, securely tighten the stud (1) with nut (2).

The clearance for the vibrating and lifting presser feet are being adjusted at maximum, so that the clearance of them should be adjusted according to the materials being sewn.

The timing position for the vibrating and lifting presser feet should be regulated by Fig. 32.

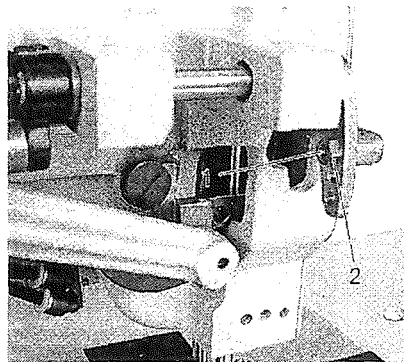

Fig.33

## 21. ADJUSTMENT OF THE THREAD CONTROLLER SPRING (Fig. 34)

For more controller action on the thread, loosen the set screw (1) at the right of the controller and set the stop lever, and for less action set the stop higher.

To strengthen the action of the controller spring on the thread, loosen the spring stud screw (4) at the rear of the stop screw and turn the spring stud (5) slightly to the left with a screwdriver, or lighten its action turn to the right and securely retighten the spring stud screw.

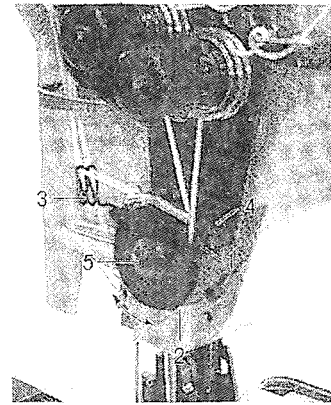

Fig.34

## 22. REPLACEMENT OF THE CONNECTION BELT

### 1) When the connection belt removed from the pulley for adjusting and or replacing purposes of the parts (Figs. 35 & 36)

- (1) Turn the machine pulley toward you so that placed the take-up lever (A) at the highest position.
- (2) Turn the hook shaft with the fingers until the arrow mark (2) on the hook driving shaft bushing collar and the red point mark (1) on the hook driving shaft bushing are directly in line.
- (3) Then replace the belt over the upper and lower pulley.

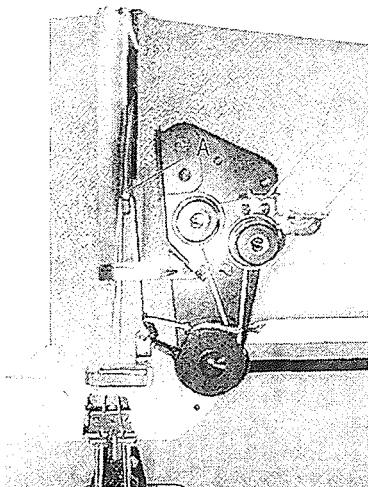

Fig.35

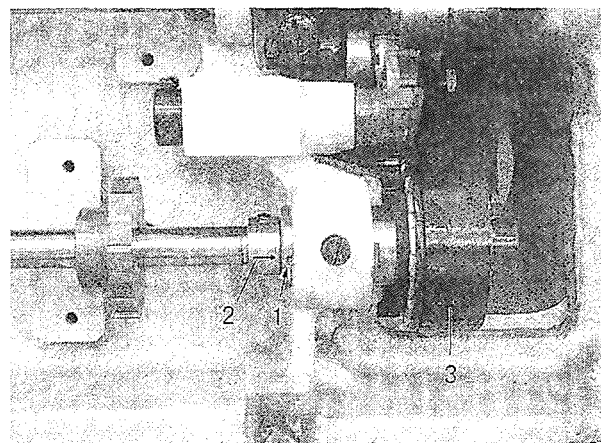

Fig.36

### 2) Replacement of the connection belt when damaged (Figs. 37 & 38)

- (1) Remove the upper arm plate and reservoir.
- (2) Slide the connection belt (A) off from lower and upper belt pulley.
- (3) Loosen the machine pulley adjustment screw (2) and two set-screws for the machine pulley (3), then remove the machine pulley.

(4) Loosen the three screws in the arm shaft bushing (5) and remove the bushing (6) .

(5) Lift the belt up through the arm cap hole after removed the bushing (6) as far as possible and draw it out through the space normally occupied by the bushing.

(6) Replace the connection belt as opposite processes as above for removing it.

(7) Securely tighten all the screws, so as to fit the arm shaft, firmly, free from looseness.

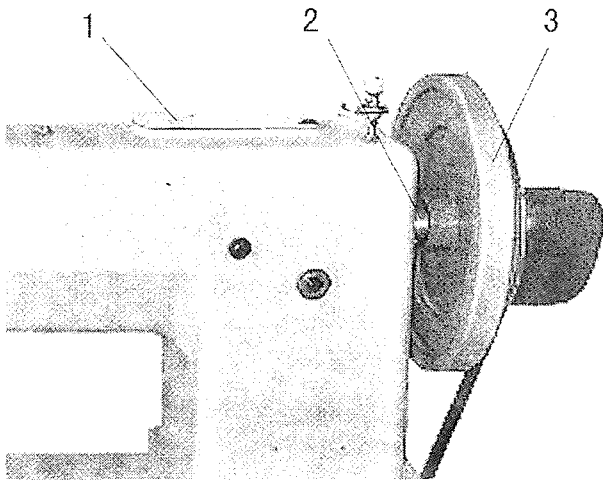

Fig.37

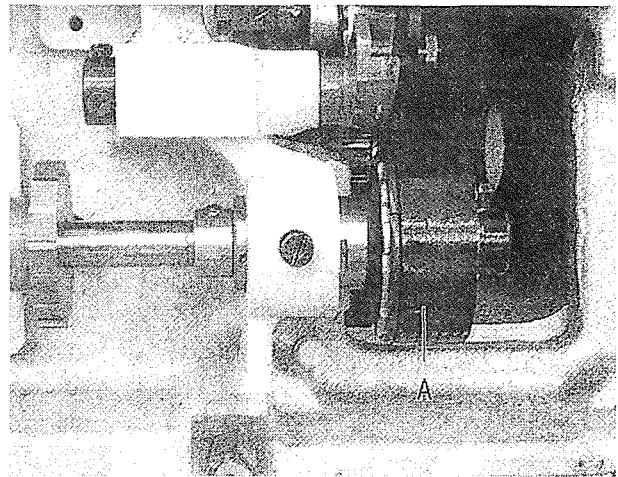

Fig.38

### 23. TO RE-ENGAGE THE SAFETY CLUTCH ( Figs. 39 & 40 )

The hook driving shaft and the shaft of the sewing hook are splined to prevent the hook from getting out of time. The safety clutch located in the lower belt pulley prevents damage in the event of thread jamming in the sewing hook by releasing the locking lever in the pulley.

Take out jammed thread from the hook.

To re-engage the clutch, press down the lock stud (A) , near the base of the arm by left hand and turn the machine pulley backward slowly by right hand, then the safety clutch will be released.

In the case easily releasing the safety clutch, adjust the pressure by the screw (B) for lower belt pulley after removed connection belt (C) .

To increase the pressure in turning the screw (B) to clockwise and to decrease the pressure in turning the screw (B) to counter-clockwise.

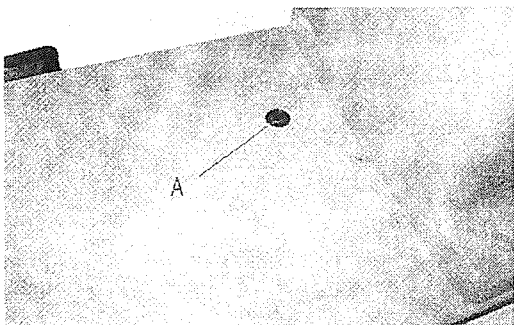

Fig.39

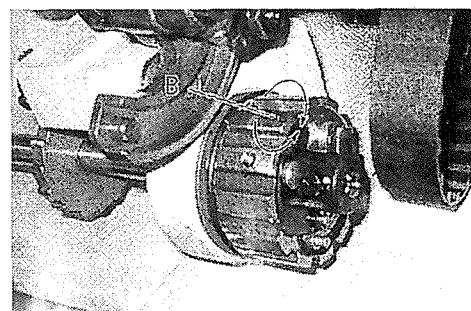

Fig.40



---

## 24. ADJUSTMENT OF THE OILING FOR THE HOOK SADDLE (Fig. 41)

Loosen the screw for the oil adjustment dial (3) and adjust oil supply by turning the oil adjustment dial (2). Maximum oil supply at the directly in line of the point mark (1) on the hook saddle and the center line of the dial (2). Stop the oil supply at the vertical position of the center line of the dial (2).

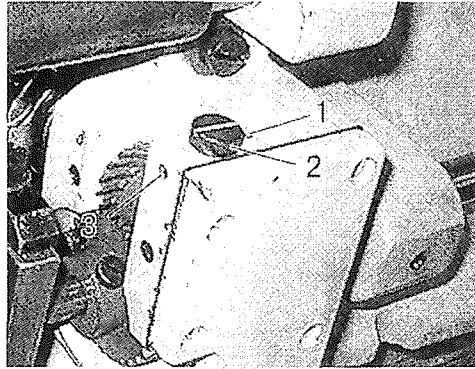
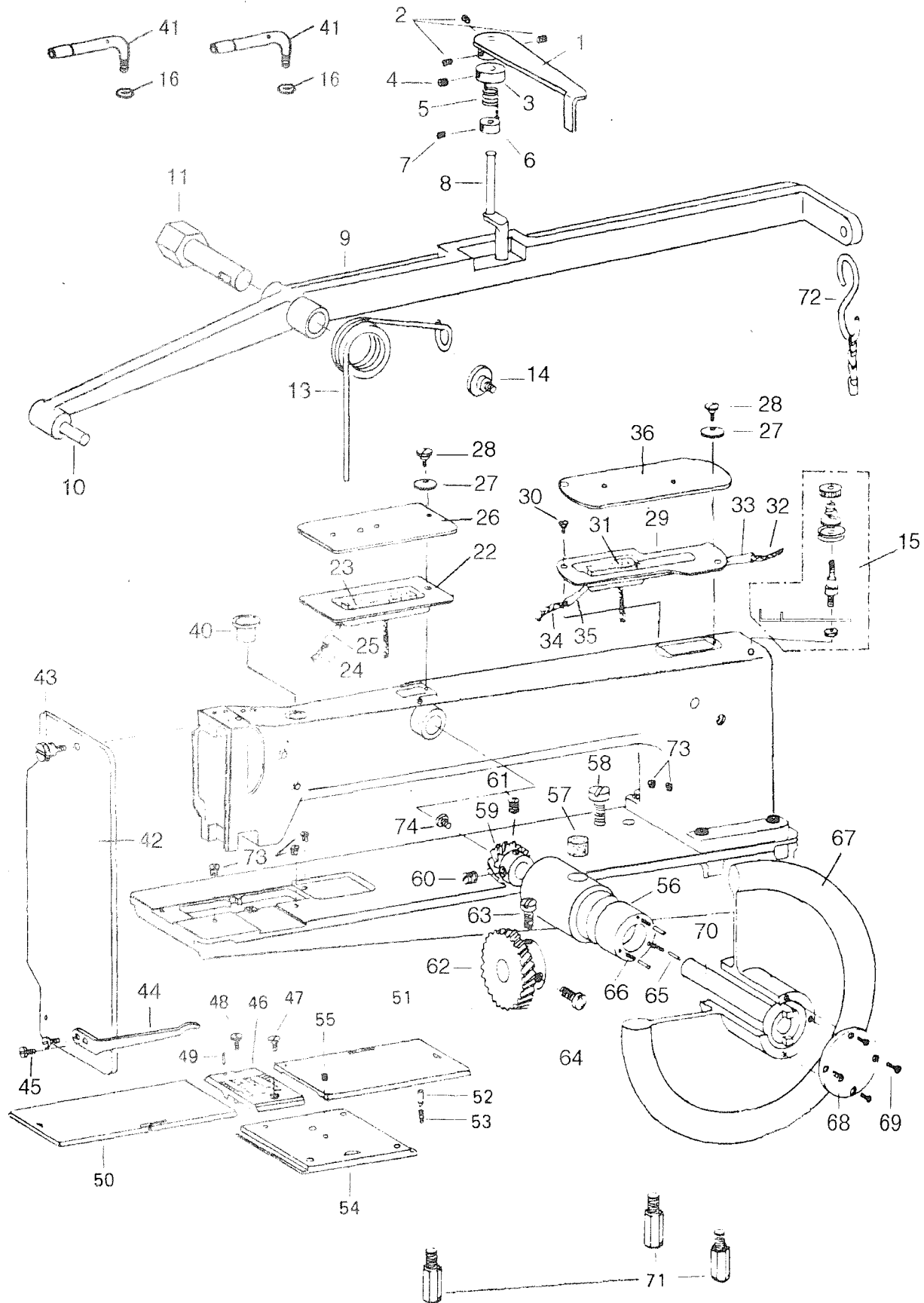

Fig.41

# A. ARM BED AND ITS ACCESSORIES



From the library of: Diamond Needle Corp

## A. ARM BED AND ITS ACCESSORIES

Fig. Nos.	Parts Nos.	Description	GC20698-5	GC20698-6	GC20698-7	GC20698-8	Remarks
A01	HE924B7101	Foot lifter lifting lever latch handle	1	1	1	1	
A02	HA100B2110	Set screw	3	3	3	3	
A03	HE913B8001	Collar (upper)	1	1	1	1	
A04	H7214H8001	screw	1	1	1	1	
A05	HE915B8001	Foot lifter lifting lever latch spring	1	1	1	1	
A06	HE916B8001	Collar (lower)	1	1	1	1	
A07	HA100C2170	Set screw	1	1	1	1	
A08	HE917B8001	Foot lifter lifting lever latch	1	1	1	1	
A09	HE918B8001	Foot lifter lifting lever			1	1	
A10	HE919B8001	Pin	1	1	1	1	
A11	HE920B8001	Foot lifter lifting lever hinge stud	1	1	1	1	
A13	HE921B8001	Foot lifter lifting lever spring	1	1	1	1	
A14	HE048D8001	Screw	1	1	1	1	
A15	H7014D7101	Down-lead complete	1	1	1	1	
A16	HE021B8001	Nut	1	2	1	2	
A22	HE949B8001	Lubricating oil cup (front).			1	1	
A23	HE950B8001	Oil pad			1	1	
A24	HE930B8001	Oil wick (A)			1	1	
A25	HE931B8001	Vinyl tube (A)			1	1	
A26	HE951B8001	Arm cap (front)			1	1	
A27	HE045D8001	Washer	1	1	2	2	
A28	H2015I0065	Stop screw	1	1	2	2	
A29	HE928B8001	Lubricating oil cup	1	1	1	1	
A30	HE111F8001	Set screw		1	1	1	
A31	HE929B8001	Oil pad		1	1		
A32	HE932B8001	Oil wick		1			
A33	HE933B8001	Vinyl tube	1	1		1	
A34	HE930B8001	Oil wick	1	1	1	1	
A35	HE931B8001	Vinyl tube	1	1	1	1	
A36	HE934B8001	Arm cap	1	1	1	1	
A40	H7327B8001	Arm oil plug	1	1	1	1	
A41	HE020B8001	Thread guide	1	2	1	2	
A42	HE937B8001	Face plate	1	1	1	1	
A43	HE938B8001	Face plate thumb screw	1	1	1	1	
A44	HE939B8001	Thread guide (lower)	1	1	1	1	
A45	HE025C8001	Screw	2	2	2	2	
A46	HE940B8001	Throat plate.		1		1	
A47	HE005H8001	Throat plate screw	1	1	1	1	
A48	HE006H8001	Throat plate position screw	1	1	1	1	
A49	H3200B2130	Throat plate stop	1	1	1	1	
A50	HE942B8001	Bed slide (left)		1		1	

## A. ARM BED AND ITS ACCESSORIES

Fig. Nos.	Parts Nos.	Description	GC20698-5	GC20698-6	GC20698-7	GC20698-8	Remarks
A51	HE943B8001	Bed slide (right)		1		1	
A52	HE946B8001	Bed slide stop	1	1	1	1	
A53	HE009H8001	Bed slide stop spring	1	1	1	1	
A54	HE944B8001	Bed plate (front)	1	1	1	1	
A55	HE013H8001	Screw	1	1	1	1	
A56	HE957B8001	Arm cross shaft bushing			1	1	
A57	HE014C8001	Oil wick			1	1	
A58	HE040D8001	Set screw	1	1	1	1	
A59	HE958B8001	Arm cross shaft gear			1	1	
A60	HE017G8001	Position screw			1	1	
A61	HE023C8001	Position screw			1	1	
A62	HE959B8001	Hand wheel driving gear			1	1	
A63	HE022G8001	Set screw			1	1	
A64	HE960B8001	Set screw			1	1	
A65	HE961B8001	Hand wheel disengaging spring plunger			3	3	
A66	HE962B8001	Hand wheel disengaging spring			3	3	
A67	HE963B8001	Hand wheel			1	1	
A68	HE964B8001	Hand wheel engaging plate			1	1	
A69	HA700F2100	Screw			4	4	
A70	HE965B8001	Arm cross shaft			1	1	
A71	HE956B8001	Machine supporting bolt	3	3	3	3	
A72	H8000H2070	Foot lifter lifting lever chain hook	1	1	1	1	
A73	H2000M0090	Ball oiler	5	5	5	5	
A74	HA700F2100	Screw			1	1	

# B. ARM SHAFT MECHANISM

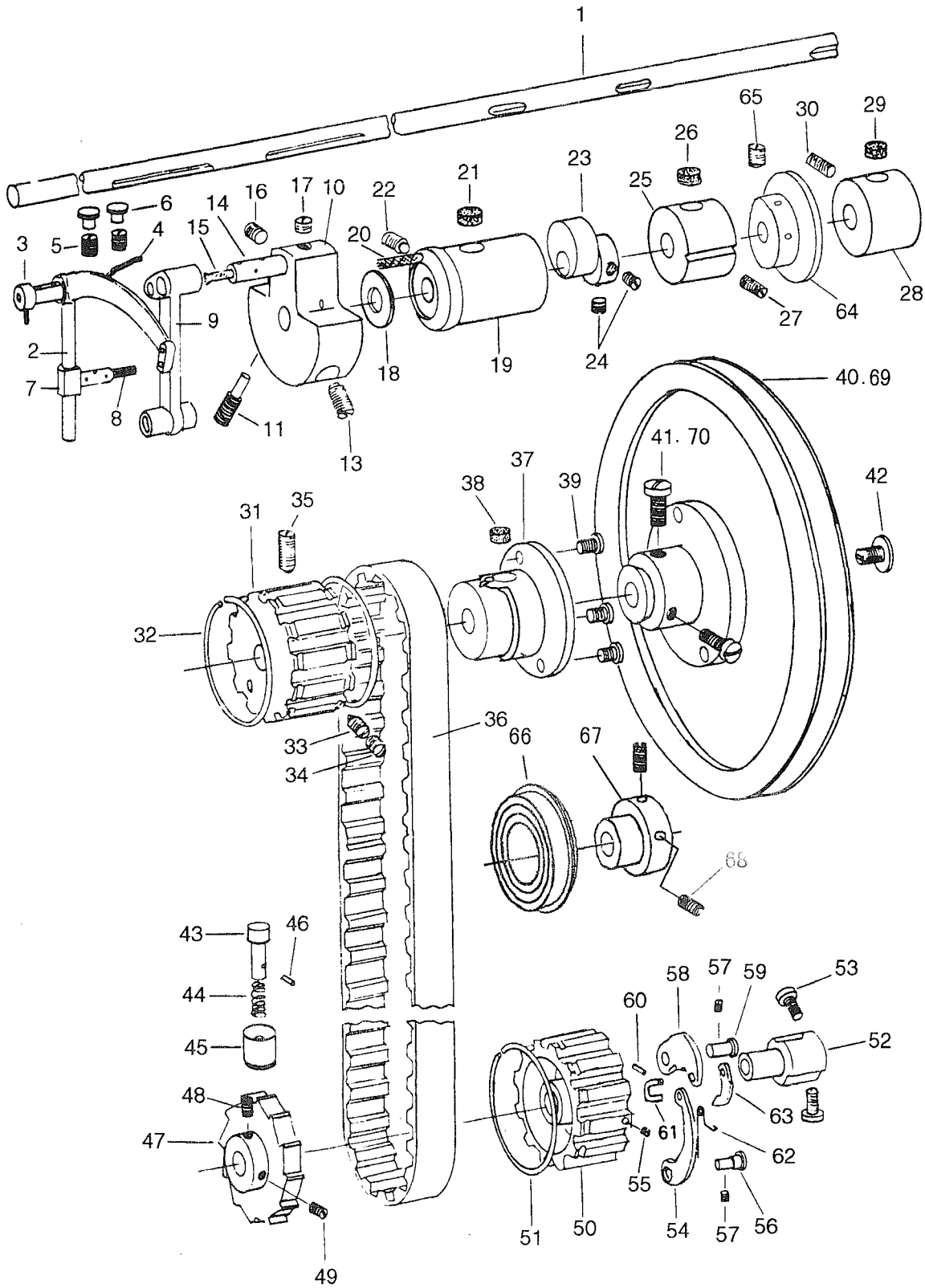

## B. ARM SHAFT MECHANISM

Fig. Nos.	Parts Nos.	Description	GC20698-5	GC20698-6	GC20698-7	GC20698-8	Remarks
B01	HE904C8001	Arm shaft			1	1	
B02	HE905C8001	Take-up lever	1	1	1	1	
B03	HE906C8001	Take-up lever hinge stud	1	1	1	1	
B04	HE907C8001	Oil wick	1	1	1	1	
B05	HE020C8001	Set screw	2	2	2	2	
B06	HA100B2150	Cap	2	2	2	2	
B07	HE908C8001	Take-up lever driving stud	1	1	1	1	
B08	HE035C8001	Oil wick	1	1	1	1	
B09	HE909C8001	Needle bar connecting link	1	1	1	1	
B10	HE910C8001	Needle bar crank	1	1	1	1	
B11	HA100C2070	Position screw	1	1	1	1	
B12	HE013C8001	Set screw	1	1	1	1	
B13	HA100C2060	Set screw	1	1	1	1	
B14	H3100C2070	Needle bar connecting link stud	1	1	1	1	
B15	HE041C8001	Oil wick	1	1	1	1	
B16	HE013C8001	Set screw	1	1	1	1	
B17	HE911C8001	Set screw	1	1	1	1	
B18	HE011C8001	Needle bar crank friction washer	1	1	1	1	
B19	HE912C8001	Arm shaft bushing (front)	1	1	1	1	
B20	HE014C8001	Oil wick	1	1	1	1	
B21	HE010G8001	Oil pad	1	1	1	1	
B22	HE028C8001	Set screw	1	1	1	1	
B23	HE914C8001	Feed driving eccentric	1	1	1	1	
B24	HE023C8001	Set screw	2	2	2	2	
B25	HE915C8001	Arm shaft center bushing (front)	1	1	1	1	
B26	HE014C8001	Oil pad	1	1	1	1	
B27	HE020C8001	Set screw	1	1	1	1	
B28	HE916C8001	Arm shaft center bushing	1	1	1	1	
B29	HE014C8001	Oil pad	1	1	1	1	
B30	HE020C8001	Set screw	1	1	1	1	
B31	HE026C8001	Arm shaft connection belt pulley	1	1	1	1	
B32	H3205C0661	Spring flange	2	2	2	2	
B33	HE006D8001	Set screw	1	1	1	1	
B34	HE030C8001	Check screw	1	1	1	1	
B35	HE028C8001	Position screw	1	1	1	1	
B36	HE917C8001	Connection belt	1	1	1	1	
B37	HE918C8001	Arm shaft bushing			1	1	
B38	HE014C8001	Oil pad			1	1	
B39	HE919C8001	Set screw			3	3	
B40	HE920C8001	Machine pulley			1	1	
B41	HE038E8001	Set screw			2	2	

## B. ARM SHAFT MECHANISM

Fig. Nos.	Parts Nos.	Description	GC20698-5	GC20698-6	GC20698-7	GC20698-8	Remarks
B42	HE007C8001	Machine pulley adjusting screw	1	1	1	1	
B43	HE921C8001	Hook driving shaft lock stud	1	1	1	1	
B44	H4107D0672	Spring	1	1	1	1	
B45	HE922C8001	Socket	1	1	1	1	
B46	H601016100	Stop	1	1	1	1	
B47	HE923C8001	Hook driving shaft lock ratchet	1	1	1	1	
B48	HE035G8001	Set screw	1	1	1	1	
B49	HE034G8001	Set screw	1	1	1	1	
B50	HE924C8001	Safety clutch pulley	1	1	1	1	
B51	H3205C0661	Spring flange	1	1	1	1	
B52	HE021G8001	Driving shaft position collar	1	1	1	1	
B53	HE022G8001	Set screw	2	2	2	2	
B54	HE925C8001	Safety clutch locking lever spring	1	1	1	1	
B55	HE926C8001	Adjusting screw	1	1	1	1	
B56	HE927C8001	Stud	1	1	1	1	
B57	HE028E8001	Stop screw	2	2	2	2	
B58	HE028G8001	Safety clutch locking lever	1	1	1	1	
B59	HE029G8001	Stud	1	1	1	1	
B60	H601012050	Safety clutch throw-in latch pin	1	1	1	1	
B61	HE027G8001	Connecting link	1	1	1	1	
B62	HE026G8001	Spring	1	1	1	1	
B63	HE031G8001	Safety clutch throw-in latch	1	1	1	1	
B64	HE939G8001	Bobbin winder driving gear	1	1	1	1	
B65	H6623C8001	Screw	2	2	2	2	
B66	H3205J0662	Bearing	1	1			
B67	HF405C8001	Arm shaft bushing(right)	1	1			
B68	HA100C2020	Screw	2	2			
B69	HF407C8001	Machine pulley	1	1			
B70	HE038E8001	Screw	2	2			

# C. PRESSER FOOT MECHANISM

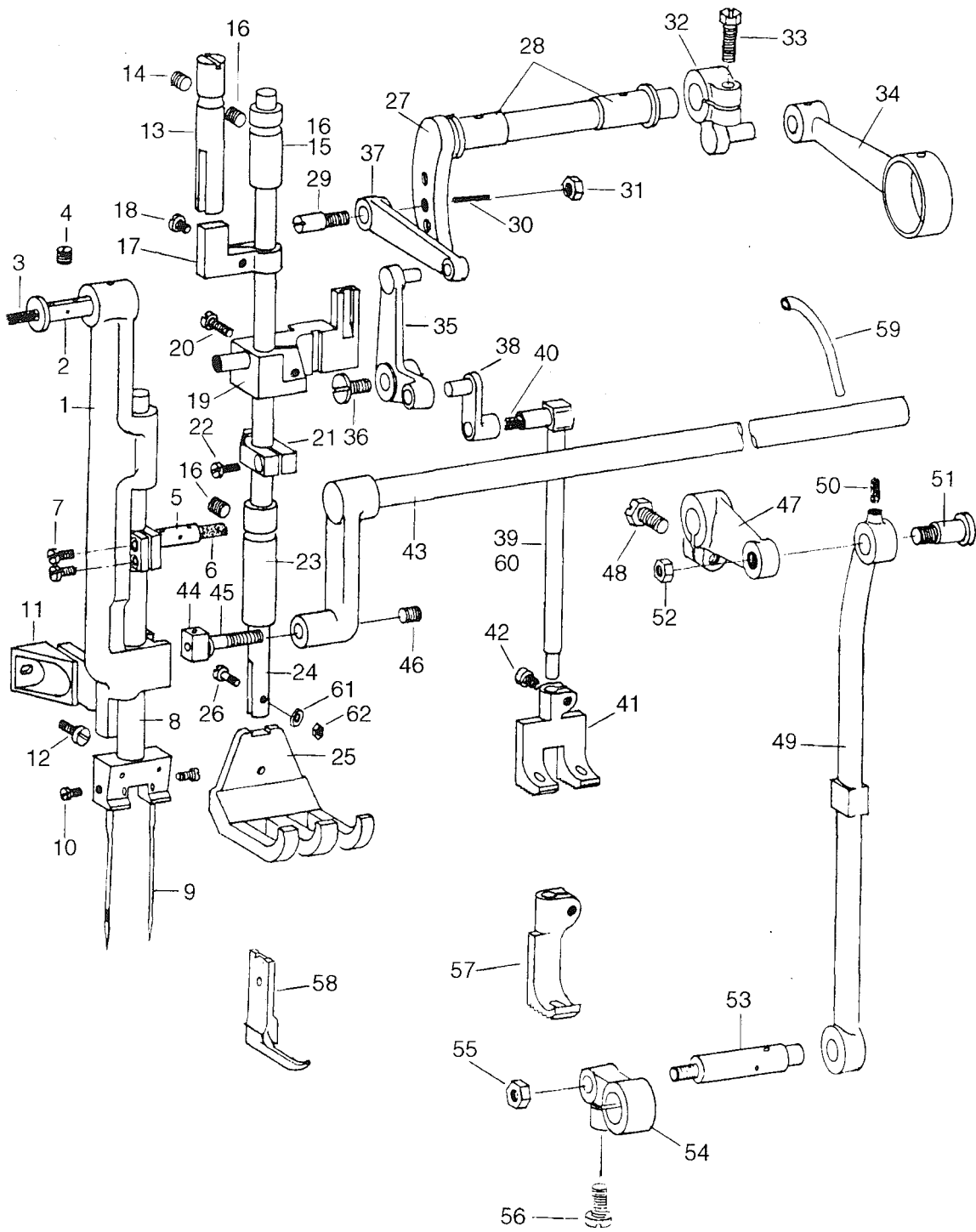

From the library of: Diamond Needle Corp



## C. PRESSER FOOT MECHANISM

Fig. Nos.	Parts Nos.	Description	GC20698-5	GC20698-6	GC20698-7	GC20698-8	Remarks
C01	HE904D8001	Needle bar rock frame		1		1	
C02	HE905D8001	Needle bar rock frame hinge stud	1	1	1	1	
C03	HE035C8001	Oil wick	1	1	1	1	
C04	HE009G8001	Set screw	1	1	1	1	
C05	HE907D8001	Needle bar connection stud	1	1	1	1	
C06	HE041C8001	Oil wick	1	1	1	1	
C07	HE119E8001	Pinch screw for 70022	2	2	2	2	
C08	HE908D8001	Needle bar		1		1	
C09	HE909D8001	Needle	1	2	1	2	
C10	HE910D8001	Needle set screw		2		2	
C11	HE911D8001	Needle bar rock frame position bracket	1	1	1	1	
C12	HE022K8001	Screw	1	1	1	1	
C13	HE912D8001	Presser bar position guide	1	1	1	1	
C14	HE006D8001	Set screw	1	1	1	1	
C15	HE007D8001	Presser bar bushing (upper)	1	1	1	1	
C16	HE006D8001	Set screw	2	2	2	2	
C17	HE913D8001	Presser bar position guide lever	1	1	1	1	
C18	HE009D8001	Pinch screw	1	1	1	1	
C19	HE914D8001	Presser bar lifting bracket	1	1	1	1	
C20	H3107G0661	Pinch screw	1	1	1	1	
C21	HE915D8001	Presser bar spring bracket	1	1	1	1	
C22	HE916D8001	Pinch screw	1	1	1	1	
C23	HE007D8001	Presser bar bushing (lower)	1	1	1	1	
C24	HE918D8001	Presser bar	1	1	1	1	
C25	HE919D8001	Lifting presser foot		1		1	
C26	HE920D8001	Pinch screw for lifting presser foot	1	1	1	1	
C27	HE921D8001	Lifting rock shaft	1	1	1	1	
C28	HE024D8001	Lifting rock shaft bushing	2	2	2	2	
C29	HE025D8001	Screw stud	1	1	1	1	
C30	HE035C8001	Oil wick	1	1	1	1	
C31	H3112F0662	Nut	1	1	1	1	
C32	HE922D8001	Lifting eccentric	1	1	1	1	
C33	HE038E8001	Position screw	1	1	1	1	
C34	HE923D8001	Lifting eccentric connection	1	1	1	1	
C35	HE924D8001	Lifting bell crank	1	1	1	1	
C36	H3107G0662	Set screw	1	1	1	1	
C37	HE925D8001	Lifting bell crank link	1	1	1	1	
C38	HE926D8001	Vibrating presser bar connecting link	1	1	1	1	
C39	HE927D8001	Vibrating presser bar	1	1	1	1	
C40	HE035C8001	Oil wick	1	1	1	1	
C41	HE928D8001	Vibrating presser foot.		1		1	

### C. PRESSER FOOT MECHANISM

Fig. Nos.	Parts Nos.	Description	GC20698-5	GC20698-6	GC20698-7	GC20698-8	Remarks
C42	HE929D8001	Set screw for vibrating presser foot	1	1	1	1	
C43	HE930D7101	Needle bar frame rock shaft			1	1	
C44	H3100F2270	Needle bar rock frame slide block	1	1	1	1	
C45	HE027E8001	Screw stud	1	1	1	1	
C46	HE028E8001	Set screw	1	1	1	1	
C47	HE933D8001	Needle bar rock frame rock shaft crank	1	1	1	1	
C48	HE038E8001	Pinch screw	1	1	1	1	
C49	HE934D8001	Crank connection	1	1	1	1	
C50	HE035C8001	Oil wick	1	1	1	1	
C51	HE935D8001	Hinge screw	1	1	1	1	
C52	HE936D8001	Nut	1	1	1	1	
C53	HE937D8001	Feed reversing crank screw stud	1	1	1	1	
C54	HE938D8001	Feed reversing crank	1	1	1	1	
C55	HE926E8001	Nut	1	1	1	1	
C56	HE038E8001	Stop screw	1	1	1	1	
C57	HF207D8001	Vibrating presser foot	1		1		
C58	HF304D8001	Lifting presser foot	1		1		
C59	HE939D8001	Vinyl tube	1	1	1	1	
C60	HF209D8001	Vibrating presser bar	1	1	1	1	
C61	HE044J8001	Washer	1	1	1	1	
C62	HE940D8001	Nut	1	1	1	1	

# D. STITCH REGULATOR MECHANISM

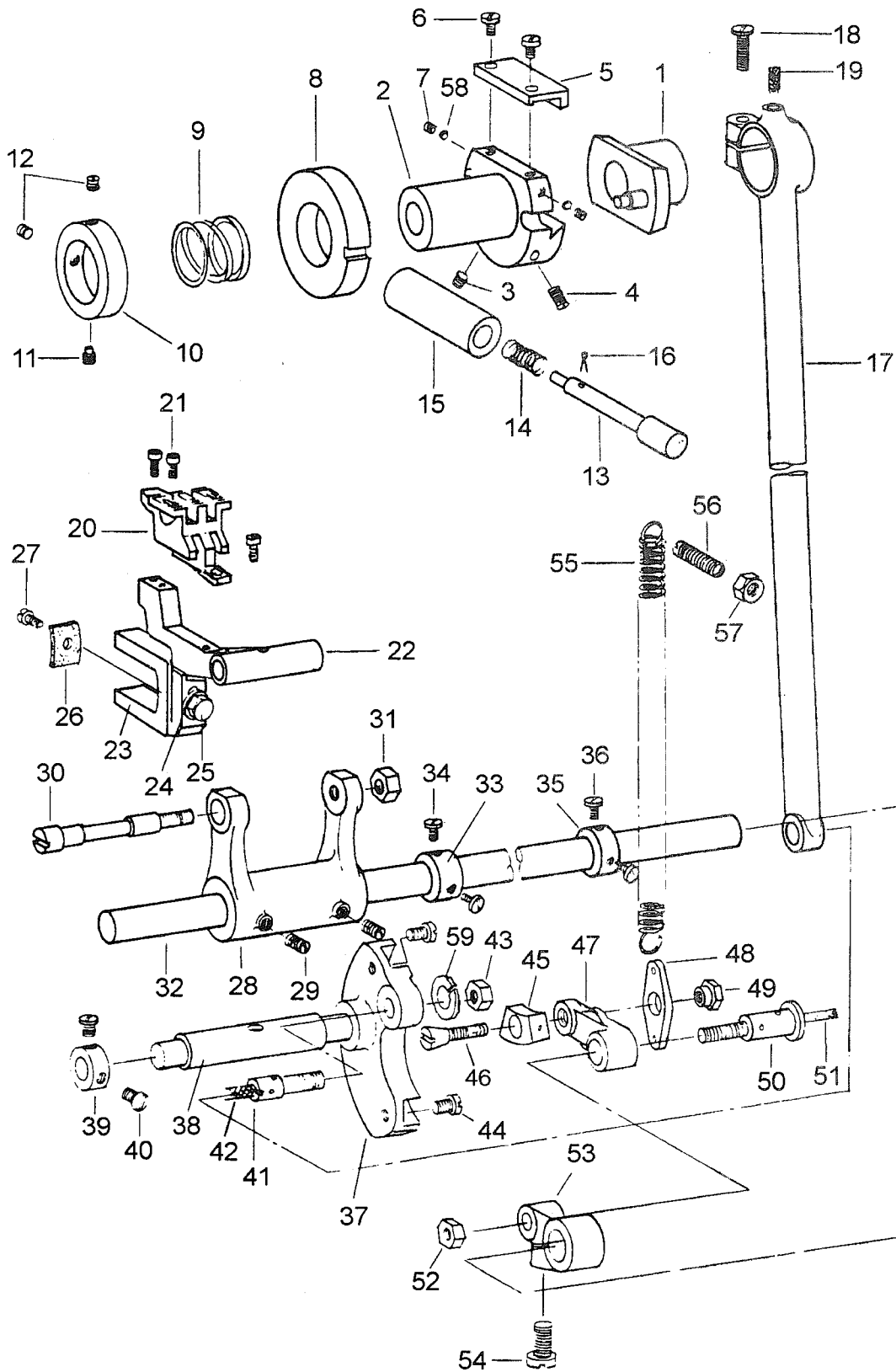

From the library of: Diamond Needle Corp

## D. STITCH REGULATOR MECHANISM

Fig. Nos.	Parts Nos.	Description	GC20698-5	GC20698-6	GC20698-7	GC20698-8	Remarks
D01	HE946E7101	Feed driving eccentric	1	1	1	1	
D02	HE905E8001	Flange	1	1	1	1	
D03	HE906E8001	Set screw	1	1	1	1	
D04	HE907E8001	Set screw	1	1	1	1	
D05	HE908E8001	Friction plate	1	1	1	1	
D06	HE909E8001	Stop screw	2	2	2	2	
D07	HA100B2110	Set screw	2	2	2	2	
D08	HE910E8001	Feed driving eccentric.adjusting disc	1	1	1	1	
D09	HE911E8001	Spring	1	1	1	1	
D10	HE912E8001	Collar	1	1	1	1	
D11	HE035G8001	Position screw	1	1	1	1	
D12	HE023C8001	Set screw	2	2	2	2	
D13	HE913E8001	Feed regulating stud	1	1	1	1	
D14	HE914E8001	Spring	1	1	1	1	
D15	HE915E8001	Bushing	1	1	1	1	
D16	H601016100	Retaining spring	1	1	1	1	
D17	HE916E8001	Feed driving connection	1	1	1	1	
D18	H4753E8001	Pinch screw	1	1	1	1	
D19	HE035C8001	Oil wick	1	1	1	1	
D20	HE917E8001	Feed dog		1		1	
D21	HE918E8001	Feed dog set screw		3		3	
D22	HE919E8001	Feed bar		1		1	
D23	HE920E8001	Feed lifting cam fork	1	1	1	1	
D24	H2013J0065	Washer	1	1	1	1	
D25	HE022H8001	Screw	1	1	1	1	
D26	HE020H8001	Oiling pad	1	1	1	1	
D27	HE025B8001	Screw	1	1	1	1	
D28	HE921E8001	Feed bar crank	1	1	1	1	
D29	HE922E8001	Set screw	2	2	2	2	
D30	HE923E8001	Feed bar hinge screw	1	1	1	1	
D31	HE131E8001	Nut	1	1	1	1	
D32	HE925E8001	Feed driving rock shaft			1	1	
D33	HE033H8001	Feed driving rock shaft stop collar	1	1	1	1	
D34	HE034H8001	Set screw	2	2	2	2	
D35	HE033H8001	Feed driving rock shaft stop collar	1	1	1	1	
D36	HE034H8001	Set screw	2	2	2	2	
D37	HE943E7101	Feed reversing lever	1	1	1	1	
D38	HE928E8001	Feed reversing lever bushing	1	1	1	1	
D39	HE929E8001	Collar	1	1	1	1	
D40	HE012E8001	Set screw	1	1	1	1	
D41	HE930E8001	Hinge screw	1	1	1	1	

# D. STITCH REGULATOR MECHANISM

Fig. Nos.	Parts Nos.	Description	GC20698-5	GC20698-6	GC20698-7	GC20698-8	Remarks
D42	HE035C8001	Oil wick	1	1	1	1	
D43	HE941E8001	Nut	1	1	1	1	
D44	HE931E8001	Stop screw	2	2	2	2	
D45	HE932E8001	Feed reversing lever slide block	1	1	1	1	
D46	HE933E8001	Hinge screw	1	1	1	1	
D47	HE934E8001	Feed reversing link	1	1	1	1	
D48	HE935E8001	Spring and treadle connecting link	1	1	1	1	
D49	HE936E8001	Hinge screw nut	1	1	1	1	
D50	HE937E8001	Hinge screw	1	1	1	1	
D51	HE035C8001	Oil wick	1	1	1	1	
D52	HE926E8001	Nut	1	1	1	1	
D53	HE938E8001	Feed reversing crank	1	1	1	1	
D54	HE939E8001	Bracket screw	2	2	2	2	
D55	HE945E8001	Feed reversing lever slide block spring	1	1	1	1	
D56	HE940E8001	Screw	1	1	1	1	
D57	HE941E8001	Nut	1	1	1	1	
D58	HE942E8001	Lining metal	2	2	2	2	
D59	H005010080	Spring washer	1	1	1	1	

# E. HOOK SADDLE MECHANISM

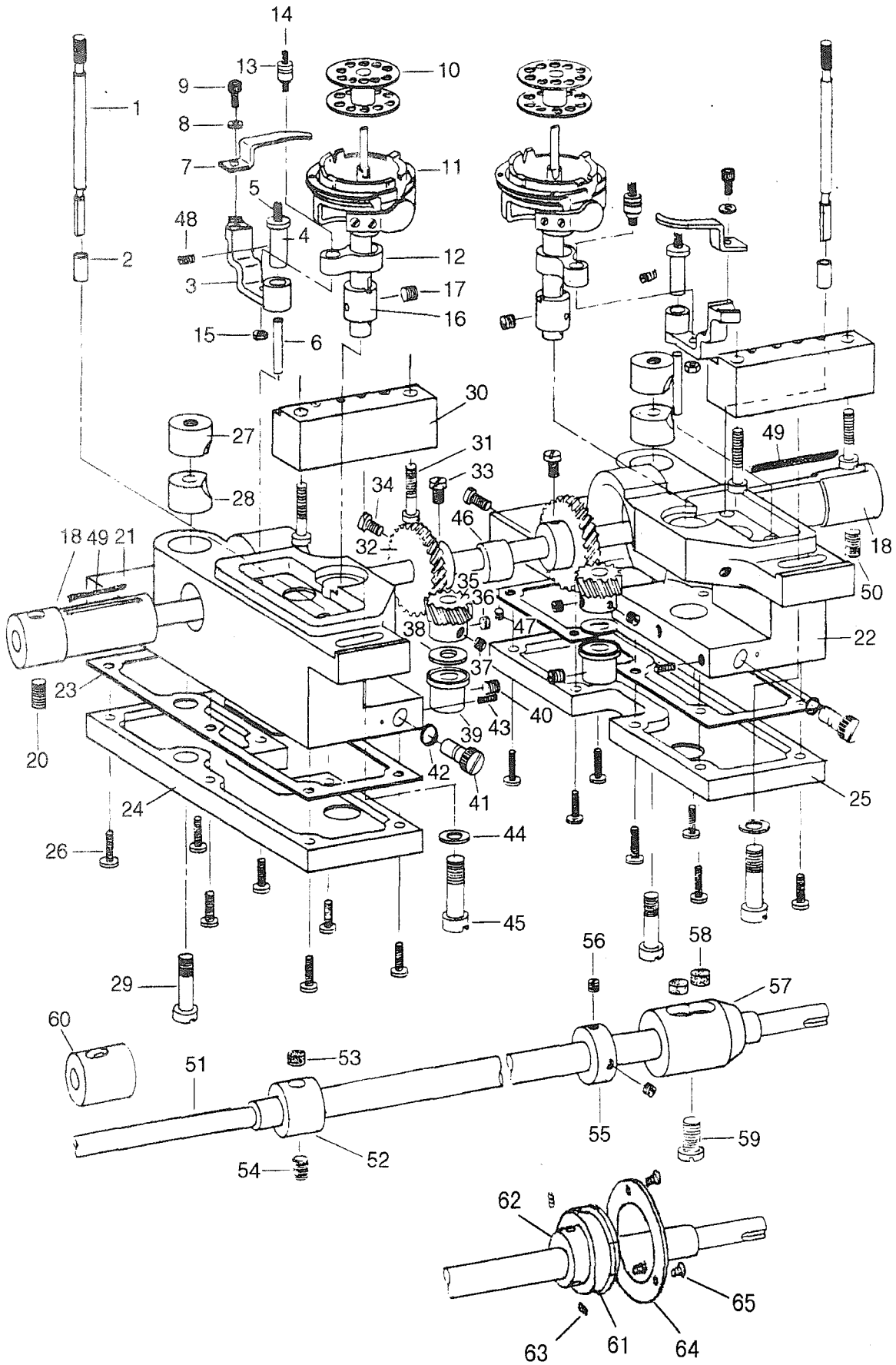

From the library of: Diamond Needle Corp

## E. HOOK SADDLE MECHANISM

Fig. Nos.	Parts Nos.	Description	GC20698-5	GC20698-6	GC20698-7	GC20698-8	Remarks
E01	HE904F8001	Oil gauge	1	2	1	2	
E02	HE039J8001	Oil gauge guide	1	2	1	2	
E03	HE905F8001	Bobbin case opener lever	1	2	1	2	
E04	HE906F8001	Bobbin case opener lever hinge stud	1	2	1	2	
E05	HE018J8001	Oil wick	1	2	1	2	
E06	HE020J8001	Oil wick vinyl tube	1	2	1	2	
E07	HE907F8001	Bobbin case opener	1	2	1	2	
E08	H005004060	Washer	1	2	1	2	
E09	HE909F8001	Screw	1	2	1	2	
E10	HE933F7101	Bobbin	1	2	1	2	
E11	HE911F8001	Hook	1	2	1	2	
E12	HE912F8001	Bobbin case opener lever link	1	2	1	2	
E13	HE017J8001	Stud	1	2	1	2	
E14	HE018J8001	Oil wick	1	2	1	2	
E15	HE019J8001	Nut	1	2	1	2	
E16	HE913F8001	Hook bushing (upper)	1	2	1	2	
E17	HE009J8001	Set screw	1	2	1	2	
E18	HE914F8001	Hook driving shaft bushing (front)		2		2	
E20	HE020C8001	Set screw	2	2	2	2	
E21	HE915F8001	Hook saddle (left)		1		1	
E22	HE916F8001	Hook saddle (right)	1	1	1	1	
E23	HE005J8001	Gasket for hook saddle		2		2	
E24	HE052J8001	Oil reservoir (left)		1		1	
E25	HE006J8001	Oil reservoir (right)	1	1	1	1	
E26	HE017B8001	Screw	7	14	7	14	
E27	HE046J8001	Hook saddle screw collar	1	2	1	2	
E28	HE046J8001	Hook saddle screw collar	1	2	1	2	
E29	HE048J8001	Hook saddle screw	1	2	1	2	
E30	HE918F8001	Bed block	1	2	1	2	
E31	HE919F8001	Bed block screw	2	4	2	4	
E32	HE055G8001	Hook driving gear	1	2	1	2	
E33	HE920F8001	Set screw	1	2	1	2	
E34	HE921F8001	Set screw	1	2	1	2	
E35	HE010J8001	Hook driving pinion	1	2	1	2	
E36	HE017G8001	Set screw	1	2	1	2	
E37	HE012J8001	Set screw	1	2	1	2	
E38	HE013J8001	Washer	1	2	1	2	
E39	HE014J8001	Hook bushing (lower)	1	2	1	2	
E40	HE009J8001	Set screw	1	2	1	2	
E41	HE040J8001	Oil adjusting dial	1	2	1	2	
E42	HE041J8001	O-ring	1	2	1	2	

# E. HOOK SADDLE MECHANISM

Fig. Nos.	Parts Nos.	Description	GC20698-5	GC20698-6	GC20698-7	GC20698-8	Remarks
E43	HE045G8001	Set screw	1	2	1	2	
E44	HE049J8001	Washer	1	2	1	2	
E45	HE050J8001	Hook saddle screw	1	2	1	2	
E46	HE058G8001	Feed lifting cam	1	1	1	1	
E47	HE017G8001	Set screw	1	1	1	1	
E49	HE010G8001	Oil wick		2		2	
E50	HE040D8001	Set screw	1	1	1	1	
E51	HE922F8001	Hook driving shaft			1	1	
E52	HE923F8001	Hook driving shaft bushing (center)	1	1	1	1	
E53	HE007G8001	Oil pad	1	1	1	1	
E54	HE034G8001	Set screw	1	1	1	1	
E55	HE924F8001	Hook driving shaft collar			1	1	
E56	HE034H8001	Position screw			2	2	
E57	HE925F8001	Hook driving shaft bushing (back)			1	1	
E58	HE926F8001	Oil pad			2	2	
E59	HE927F8001	Set screw			1	1	
E60	HE914F8001	Lower shaft front metal	1		1		
E61	HF405F7101	Hook driving shaft bushing complete (back)	1	1			
E62	HF406F8001	Hook driving shaft bushing (back)	1	1			
E63	HA307C0662	Set screw	2	2			SM1/4 (40) × 6
E64	H4727H8001	cover board	1	1			
E65	HA7311C306	set screw	3	3			



# F. THREAD TENSION REGULATOR MECHANISM

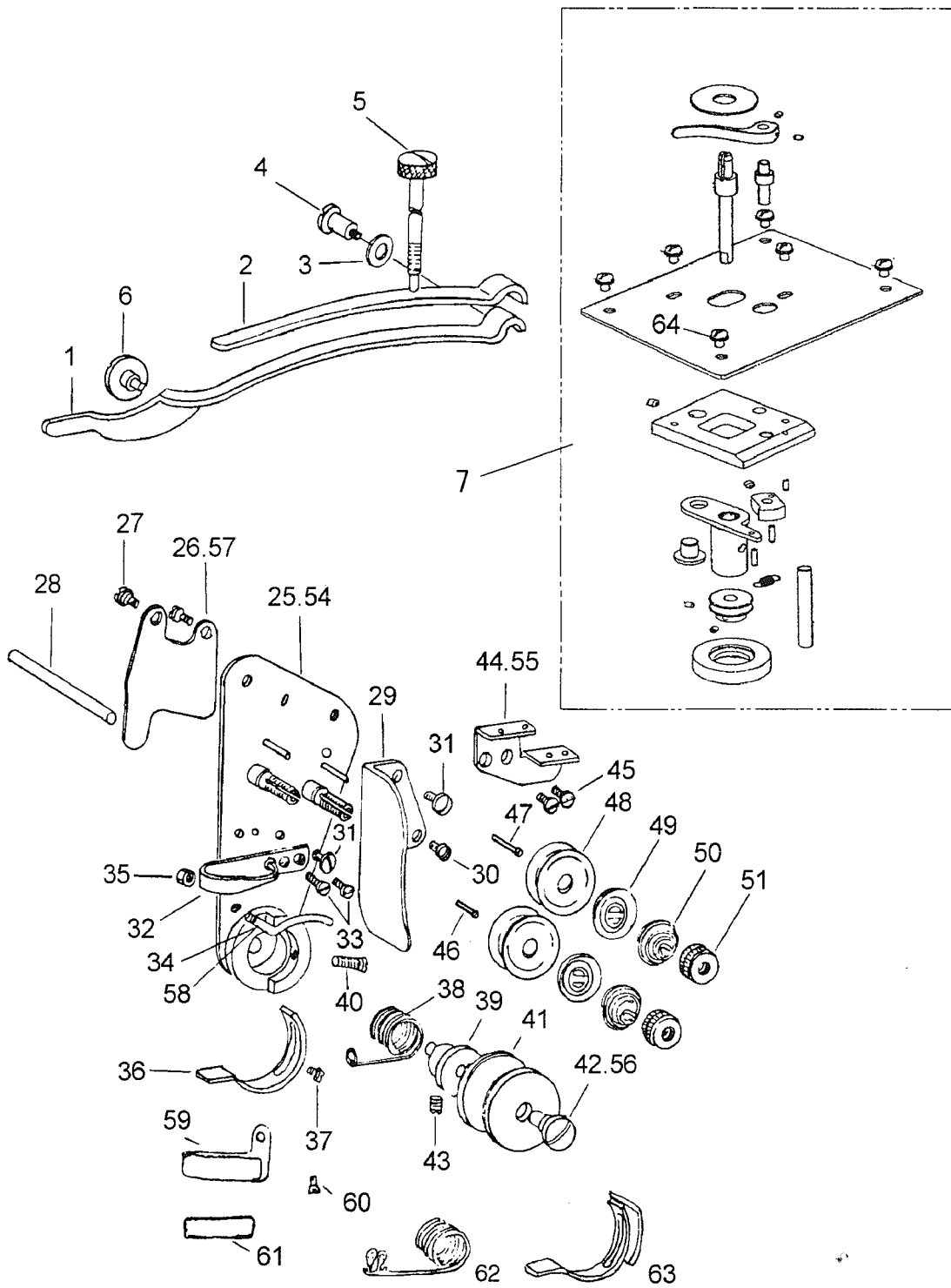

## F. THREAD TENSION REGULATOR MECHANISM

Fig. Nos.	Parts Nos.	Description	GC20698-5	GC20698-6	GC20698-7	GC20698-8	Remarks
F01	HE904G8001	Presser bar spring (flat)	1	1	1	1	
F02	HE905G8001	Presser bar spring (auxiliary)	1	1	1	1	
F03	H005006080	Presser bar spring support screw washer	1	1	1	1	
F04	HE907G8001	Presser bar spring support screw	1	1	1	1	
F05	HE908G8001	Presser bar spring regulating screw	1	1	1	1	
F06	HE048D8001	Presser bar lifting bracket guide screw	1	1	1	1	
F07	HE933G7101	Bobbin complete	1	1	1	1	
F25	HE925G8001	Tension bracket		1		1	
F26	HE910G8001	Tension release lever		1		1	
F27	HE019K8001	Screw for tension release lever	2	2	2	2	
F28	HE912G8001	Tension release plunger	1	1	1	1	
F29	HE913G8001	Thread controller covering plate	1	1	1	1	
F30	HE046C8001	Stop screw	1	1	1	1	
F31	HE012E8001	Stop screw	2	2	2	2	
F32	HE914G8001	Thread guide (lower)	1	1	1	1	
F33	HE915G8001	Screw	2	2	2	2	
F34	HE916G8001	Thread controller thread guide (lower)	1	1	1	1	
F35	HE018H8001	Nut	1	1	1	1	
F36	HE931G8001	Thread controller spring stop		1		1	
F37	HE046C8001	Stop screw	1	1	1	1	
F38	HF205G8001	Thread controller spring		1		1	
F39	HE917G8001	Thread controller spring stud	1	1	1	1	
F40	HE022K8001	Set screw	1	1	1	1	
F41	HE918G8001	Thread controller disc	1	1	1	1	
F42	HE919G8001	Thread controller stud		1		1	
F43	HE920G8001	Set screw for thread controller stud	1	1	1	1	
F44	HE921G8001	Thread controller thread guide		1		1	
F45	HE915G8001	Set screw	2	2	2	2	
F46	HE922G8001	Tension release plunger (short)	1	1	1	1	
F47	HE923G8001	Tension release plunger (long)		1		1	
F48	HA310B0705	Tension disc	2	4	2	4	
F49	HA310B0702	Tension disc	1	2	1	2	
F50	H2206B0671	Tension spring	1	2	1	2	
F51	HA310B0701	Tension thumb nut	1	2	1	2	
F54	HF206G7101	Tension bracket	1		1		
F55	HF208G8001	Thread controller thread guide	1		1		
F56	HF209G8001	Thread controller stud	1		1		
F57	HF210G8001	Tension release lever	1		1		
F58	HF211G8001	Thread controller thread guide (lower)	1	1	1	1	
F59	HE033B8001	Thread guide	1	1	1	1	
F60	HE032B8001	Set screw	1	1	1	1	

# F. THREAD TENSION REGULATOR MECHANISM

Fig. Nos.	Parts Nos.	Description	GC20698-5	GC20698-6	GC20698-7	GC20698-8	Remarks
F61	H3108B0692	Felt	1	1	1	1	
F62	HE929G8001	Thread controller spring	1		1		
F63	HE930G7101	Thread controller spring stop	1		1		

# G. PARTS FOR SINGLE NEEDLE

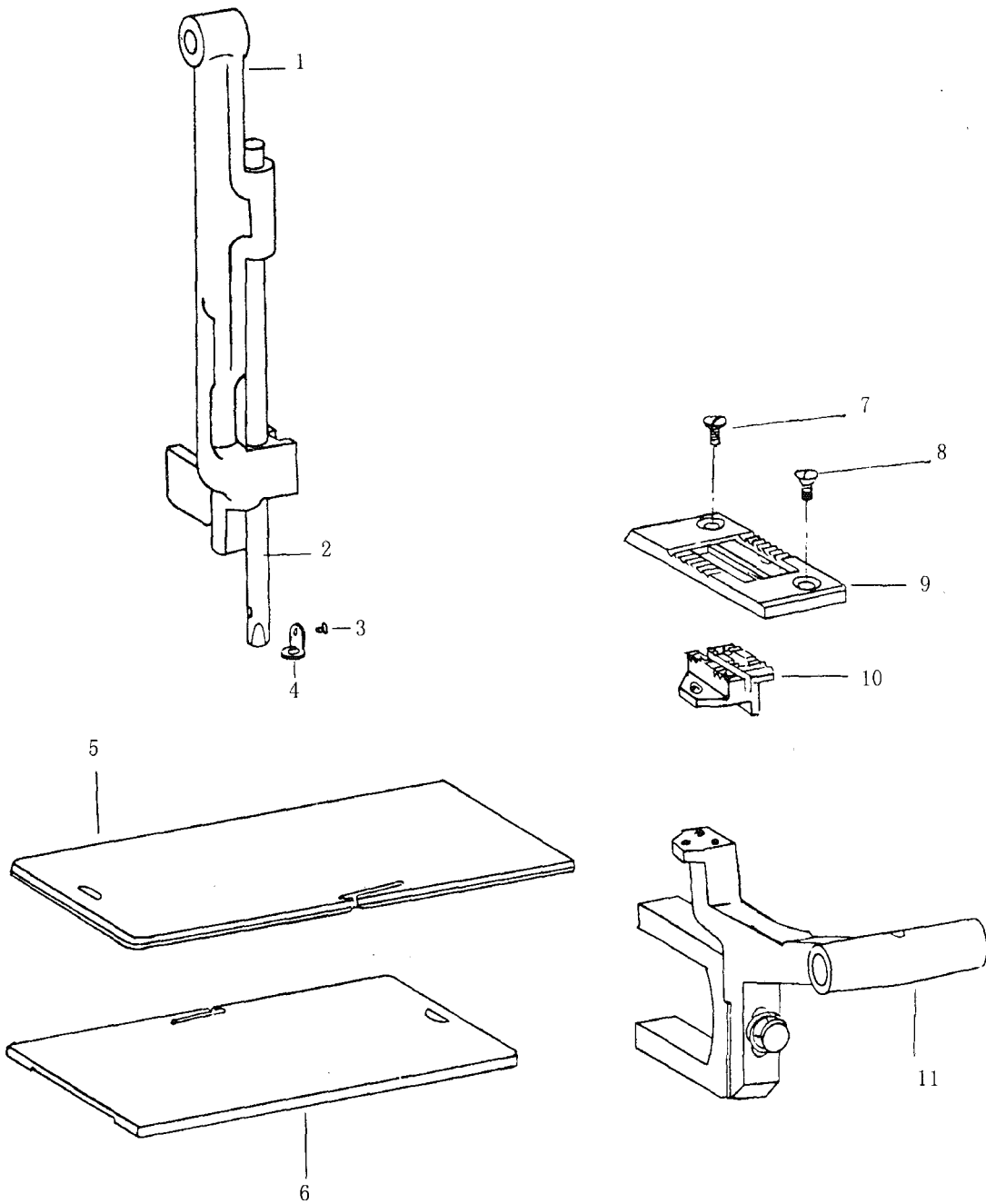









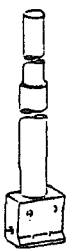
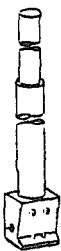
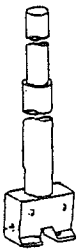
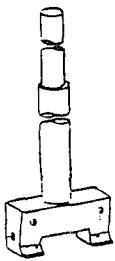
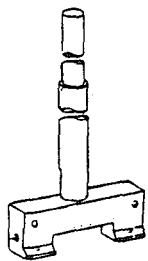



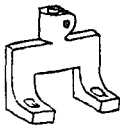
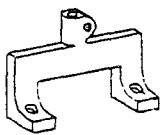

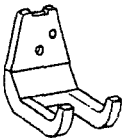
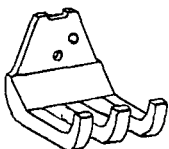
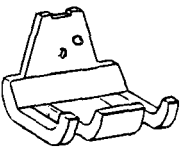
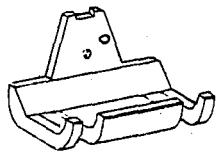

From the library of: Diamond Needle Corp

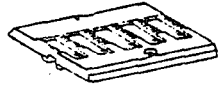
## G. PARTS FOR SINGLE NEEDLE

Fig. Nos.	Parts Nos.	Description	GC20698-5	GC20698-6	GC20698-7	GC20698-8	Remarks
G01	HF204D8001	Needle bar rock frame	1		1		
G02	HF205D8001	Needle bar	1		1		
G03	H4915J8001	Set screw	1		1		
G04	HF206D8001	Thread guide	1		1		
G05	HF210B8001	Bed plate(left)	1		1		
G06	HF211B8001	Bed plate(right)	1		1		
G07	HE005H8001	Throat plate screw	1		1		
G08	HE006H8001	Throat plate position screw	1		1		
G09	HF209B8001	Throat plate	1		1		
G10	HF205E8001	Feed dog	1		1		
G11	HF206E8001	Feed bar	1		1		

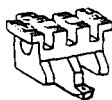
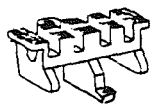
# H. PARTS FOR TWIN NEEDLE

					
1/4"	3/8" 1/2"	3/4" 7/8"	1"      1-1/4"	1-1/2" 1-3/4"	
					
1/4"	3/8" 1/2"	3/4" 7/8"	1"      1-1/4"	1-1/2" 1-3/4"	
					
1/4"	3/8" 1/2"	3/4" 7/8"	1"      1-1/4"	1-1/2" 1-3/4"	
					
1/4"	3/8" 1/2"	3/4" 7/8"	1"      1-1/4"	1-1/2" 1-3/4"	
					
1/4"	3/8" 1/2"	3/4" 7/8"	1"      1-1/4"	1-1/2" 1-3/4"	
					
1/4"	3/4"	1-1/2"	1/2"	3/4"	1-1/4"
1/2"	7/8"	1-1/4"	1/4"	7/8"	1-1/2"
3/8"	1"	1-3/4"	3/8"	1"	1-3/4"

# I. SPECIAL PARTS FOR 20"

---

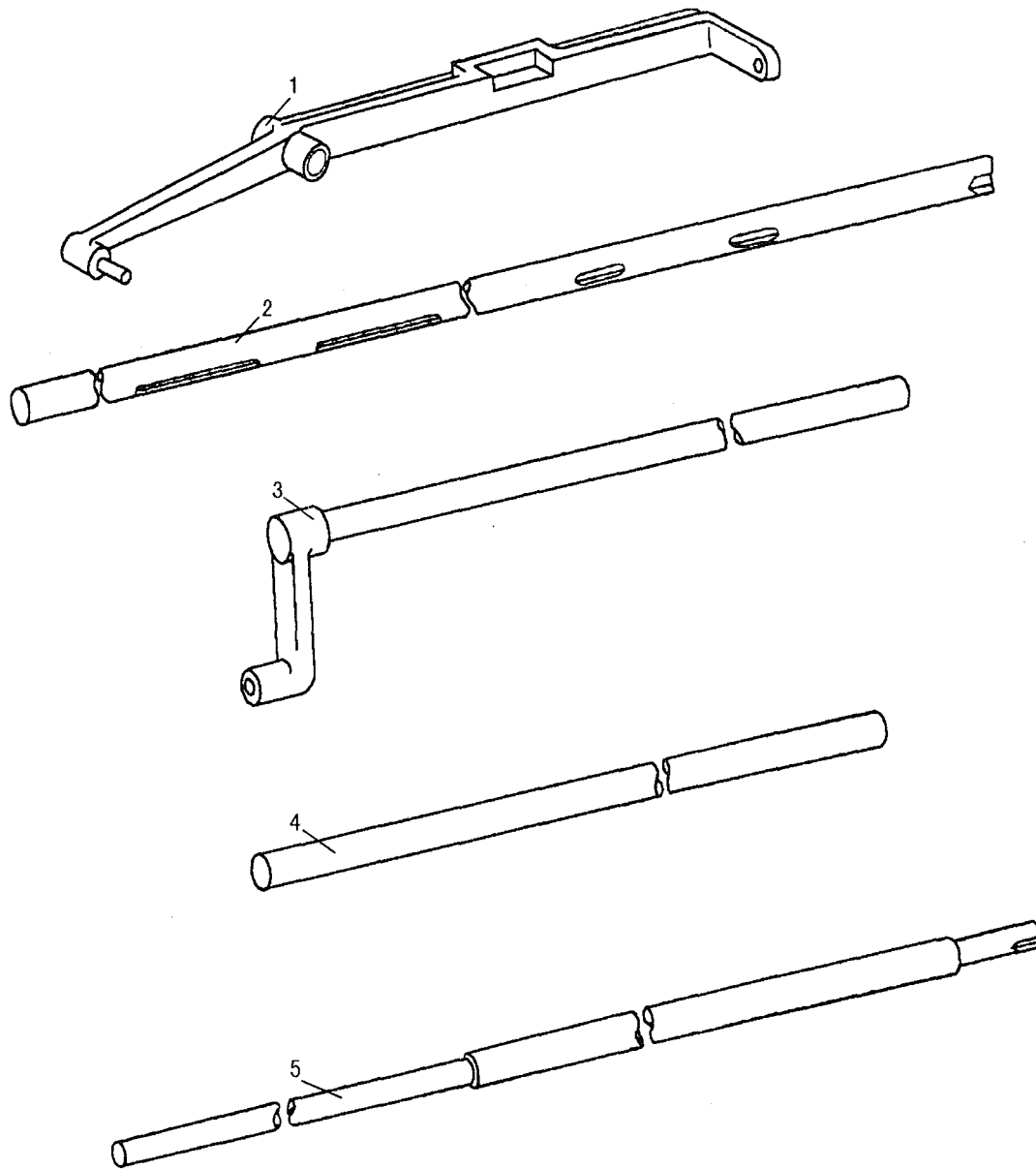

From the library of: Diamond Needle Corp

I. SPECIAL PARTS FOR 20"

Fig. Nos.	Parts Nos.	Description	GC20698-5	GC20698-6	GC20698-7	GC20698-8	Remarks
I01	HF410B8001	Foot lifting lever	1	1			
I02	HF404C8001	Arm shaft	1	1			
I03	HF404D7101	Needle bar frame rock shaft	1	1			
I04	HF404E8001	Feed driving rock shaft	1	1			
I05	HF404F8001	Hook driving shaft	1	1			



# J. ACCESSORIES

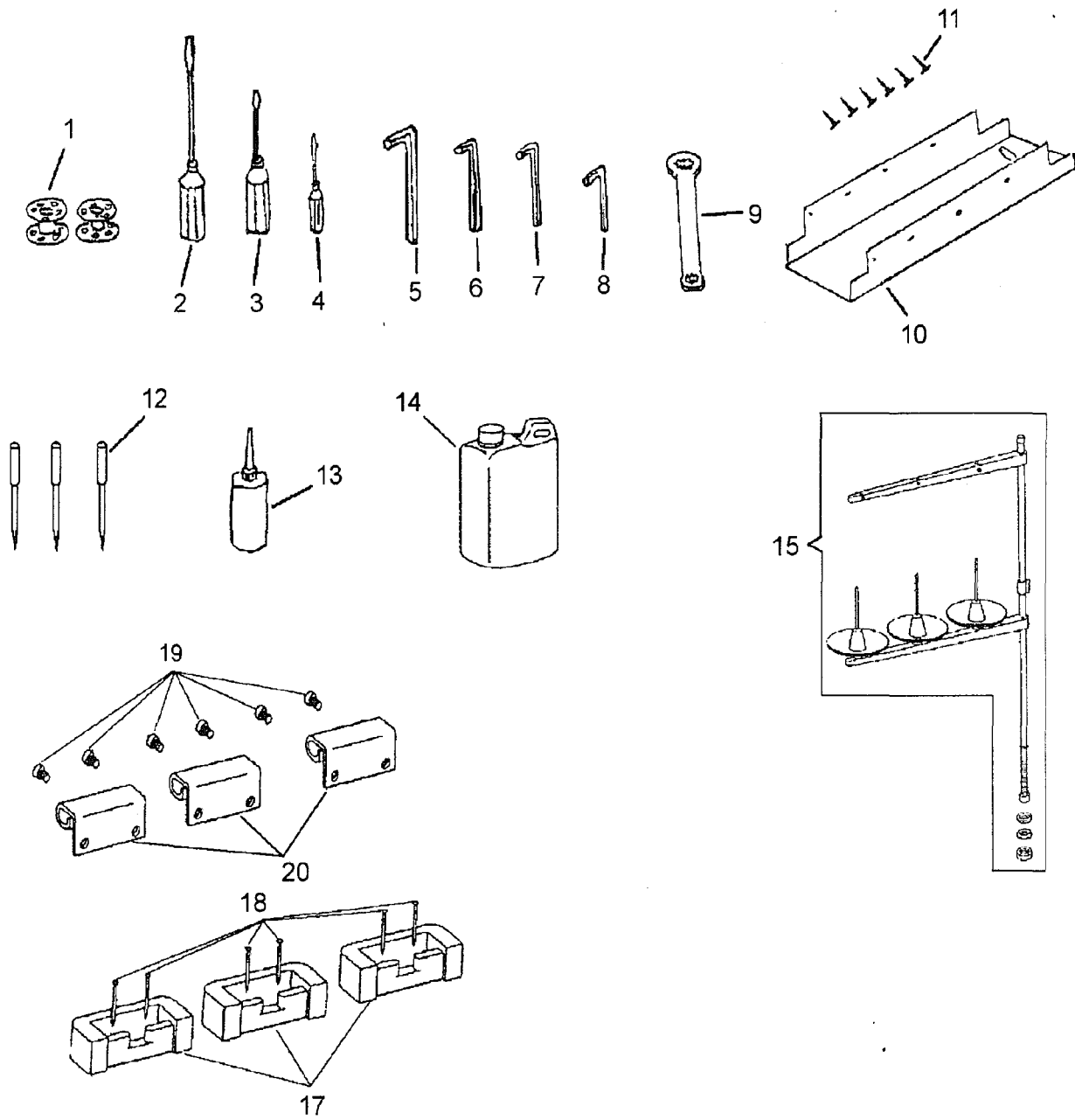

From the library of: Diamond Needle Corp

## J. ACCESSORIES

Fig. Nos.	Parts Nos.	Description	GC20698-5	GC20698-6	GC20698-7	GC20698-8	Remarks
J01	HE933F7101	Bobbin	2	4	2	4	
J02	HA300J2070	Screw driver (large)	1	1	1	1	
J03	HA300J2200	Screw driver (middle)	1	1	1	1	
J04	HA300J2210	Screw driver (small)	1	1	1	1	
J05	HB00001040	Wrench 4.0 mm	1	1	1	1	
J06	HB00001030	Wrench 3.0 mm	1	1	1	1	
J07	HB00001025	Wrench 2.5 mm	1	1	1	1	
J08	HB00001015	Wrench 1.5 mm	1	1	1	1	
J09	HA300J2220	Double head wrench	1	1	1	1	
J10	HE905H8001	Oil pan	1	1	1	1	
J11	016250	Nail	10	10	10	10	
J12	HE909D8001	Needle	3	6	3	6	
J13	H200400069	Oiler	1	1	1	1	
J14	HA300J2170	Oil	1	1	1	1	
J15	H3200L0120	Thread stand	1	1	1	1	
J17	HA307J0671	Vibration preventing rubber	3	3	3	3	
J18	016250	Nail	6	6	6	6	
J19	HE010M8001	Screw	6	6	6	6	
J20	HE009M8001	Bed hinge	3	3	3	3	



**SHANGHAI HUIGONG NO.3 SEWING MACHINE FACTORY**

**ADD: 1418, Yishan Road, Shanghai, China**

**Zip Code: 201103**

**Overseas Business: TEL: 86-21-64853303 FAX: 86-21-64854304**

**E-mail: [highlead@online.sh.cn](mailto:highlead@online.sh.cn) <http://www.highlead.com.cn>**

The description covered in this manual is subject to change for improvement of the commodity without notice

2008.10. Printed