

HIGHLEAD

GC20638-25/-25D

**Long Arm Compound Feed Split Needle Bar Lockstitch
Sewing Machine**

**Instruction Manual
Parts Catalog**

--- CONTENTS ---

Instruction Manual

1. PREPARATION FOR OPERATION	1
1) Lamp leads	1
2) Connection of control box	1
3) Adjustment of needle bar stop position	2
2. CAUTIONS ON USE	2
1) Lubrication (1)	2
2) Lubrication (2)	2
3) Adjustment of oiling to rotating hook	2
4) Condition of oil lubrication	3
5) Cautions on operation	3
3. OPERATION	3
1) How to attach needle	3
2) How to wind the lower thread	3
3) Selection of Thread	3
4) How to route the upper thread	4
5) Adjustment of stitch length and reverse sewing	4
6) Setting bobbin	4
7) Threading of bobbin thread	5
8) Tension adjustment of bobbin threads	5
9) Balance of thread tension	5
10) Needle thread tension	5
11) Adjustment of pressure of presser foot	5
12) Timing between rotating hook motion and needle motion	6
13) Adjustment of Feed dog height	6
14) Adjustment the needle stop position	6
15) Needle bar stop position (left & right)	7
16) Walking foot and presser foot vertical stroke adjustment	7
17) Relationship between rotating hook motion and take-up lever motion	7
18) Relationship between hook motion and opener motion	7
19) Relationship between needle motion and feed dog motion	8
20) Safe clutch device	8

21) Adjustment	9
22) Installation of movable knife	9
23) Adjustment of thread trimmer cam	10
24) Adjustment of threads tension release assembly	11
25) Adjustment of scissoring pressure of movable knife and fixed knife	11
26) Sharpening of fixed knife	12
27) Adjustment for change of needle-to-needle distance	12

Parts Catalog

A、 ARM BED MECHANISM	13
B、 THREAD TENSION REGULATOR MECHANISM	16
C、 ARM SHAFT*LOWER SHAFT MECHANISM	20
D、 PRESSER FOOT MECHANISM.	22
E、 NEEDLE BAR & TAKE-UP LEVER MECHANISM	25
F、 TOP FEED ROCK SHAFT MECHANISM	28
G、 LOWER SHAFT & FEED ROCK SHAFT MECHANISM	30
H、 HOOK SADDLE MECHANISM	33
I、 KNIFT MECHANISM (1)	35
J、 KNIFT MECHANISM (2)	37
K、 TOUCH BACK AND DETECTOR MECHANISM	40
L、 OIL LUBRICATION MECHANISM	42
J、 ACCESSORIES	44

1. PREPARATION FOR OPERATION

1) Lamp Leads

- A. When installing the illuminating lamp (6V, 15-20W), The connecting wire is attached on the back of the Control box. It should be removed and connected by removing the insulating tube from the wire and stripping properly. The wire connections should be, then, insulated by wrapping insulating tape on the wires.

CAUTION: The power switch must be turned off before connecting the lamp.

- B. When the illuminating lamp is not used, the end of the lamp leads must be insulated as (a) or (b) as shown in the figure on right side. If a short circuit occurs failing to insulate, the transformer in the control box will be possibly burned out.

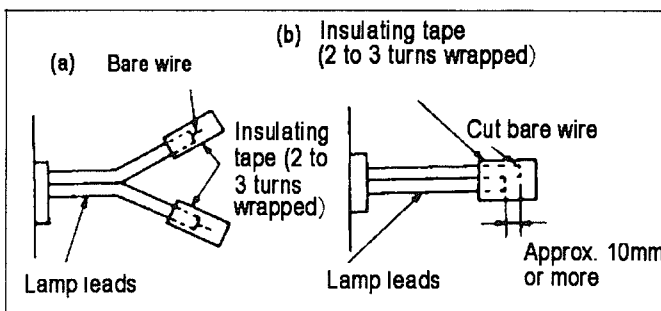

CAUTION: The illuminating lamp must not be connected with any heater, such as a foot warmer and others, in parallel. Otherwise, the load capacity will be exceeded. It may cause transformer winding burned out.

- C. Rotary direction

It is possible to change the rotary direction of the motor by removing the rubber cap from the bottom left side of the front cover on the control box, and push the internal direction selector switch. The built-in lamp in the internal switch is off when the motor is rotating counterclockwise as facing to the motor pulley, and on when rotating clockwise. The rotary direction has been set to counterclockwise as facing to the motor pulley, matching with the machine prior to shipping.

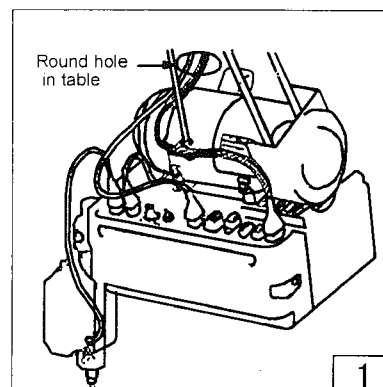

2) Connection of control box(Fig.1)

The control box should be connected as shown to the right.

Note:

- A. Be sure to turn the power switch off for safety before connecting or disconnecting the connectors.
- B. The combination of the machine heads with the motor control panels are specified below. Use special care for the correct combination when replacing the machine head or motor control panel.

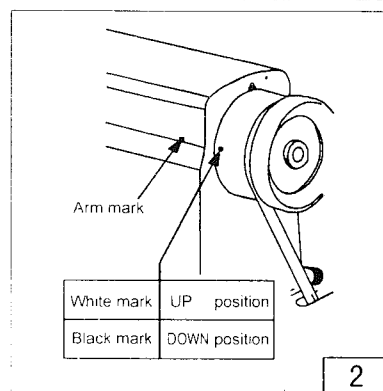

3) Adjustment of needle bar stop position(Fig.2, Fig.3)

- A. Adjust of "UP" position: When the pedal is kicked down by heel, the machine stops at "UP" position. If the marks deviate larger than 3 mm, adjust as follows.
- Disconnect the plug (12 pins) of cable from the machine head.
 - Run the machine and stop at "UP" position.
 - While holding the pulley, insert the "adjusting tool" in the hole "A", then remove the tool.
- B. Adjust of "Down" position: When the pedal is "Neutral" the machine stops at "Down" position. If the marks deviate large than 5 mm, adjust as follows.
- Disconnect the plug (12 pins) of cable from the machine head.
 - Run the machine and stop at "Down" position.
 - While holding the pulley, insert the "adjusting tool" in the hole "B", then remove the tool.
- C. Confirm the stop operation, then set the plug (12 pins) coming from the machine head into the receptacle.

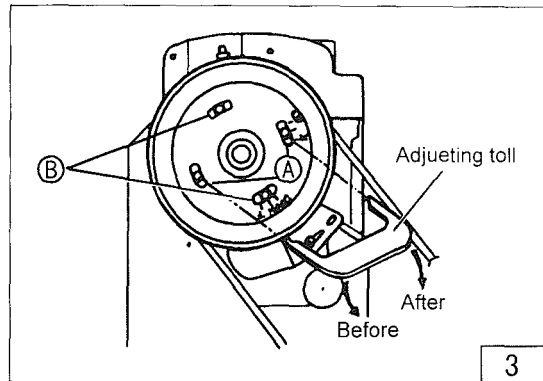

2. CAUTIONS ON USE

1) Lubrication (1)(Fig.4)

Filling the oil to the fount.

Oil level should be periodically checked. If oil level is little, Please replenish oil to enough

For oil, Use white spindle oil1.

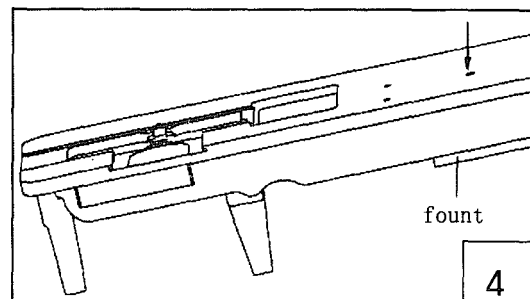

2) Lubrication (2)(Fig.5)

When a new sewing machine is used for the first time, or sewing machine left out of use for a long time is used again, replenish a suitable amount of oil to the portions indicated by arrow in the fig.

Note: Lubricate the Hook Base everyday.

3) Adjustment of oiling to rotating hook(Fig.6)

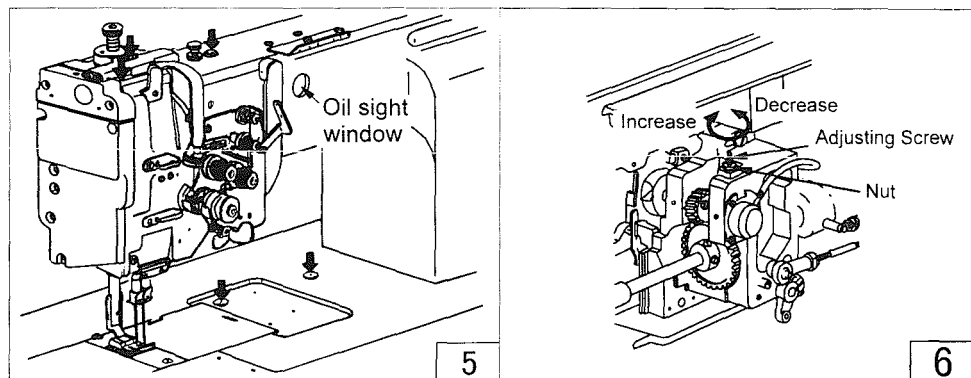

4) Condition of oil lubrication (Fig.5):

While operating the machine, check the condition of oil lubrication through the oil check window.

5) Cautions on operation

- A When the power is turned on or off, keep foot away from the pedal.
- B It should be noted that the brake may not work when the power is interrupted or power failure occurs during sewing machine operation.
- C Since dust in the control box might cause malfunction or control troubles, be sure to keep the control box cover close during operation.
- D Do not apply a multimeter to the control circuit for checking; otherwise voltage of multimeter might damage semiconductor components in the circuit.

3.OPERATION

1) How to attach needle (Fig.7):

Note: Before attach needle, be sure to turn off the power.

Loosen the needle clamping screw; Hold the needles so that the two needles side with the long grooved (faces each other), and insert it as deeply as it will go into the needle clamping holes, tighten screws.

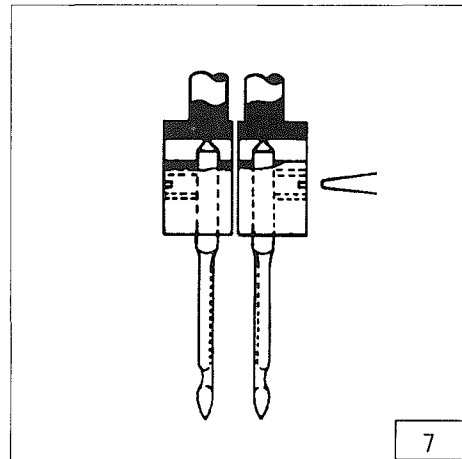

2) How to wind the lower thread (Fig.8):

Strength of winding: Particularly in the case of nylon or polyester thread, wind the bobbin loosely.

Uneven winding: If the bobbin is wound unevenly, slide the thread guide toward the less wound portion of bobbin.

Winding amount: When the bobbin is wound excessively, loosen the adjusting screw. When the bobbin is wound insufficiently, tighten the adjusting screw.

3) Selection of Thread (Fig.9):

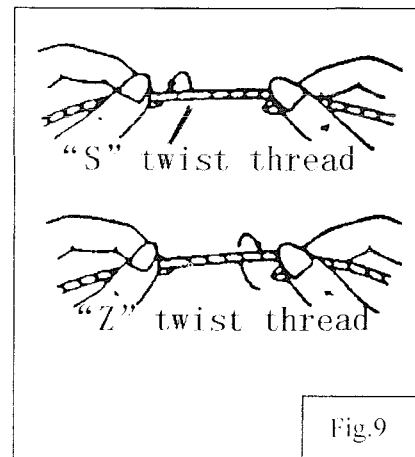
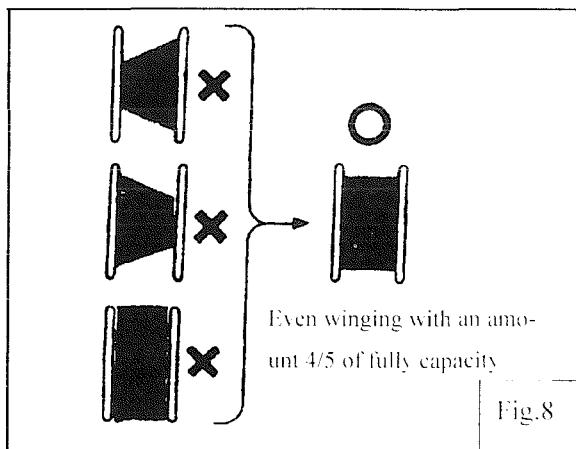

It is recommended to use “S” twist thread in the left needle (Viewed from front), and “Z” twist thread in the right needle.

When discriminate use of needle thread is impossible, use “Z” twist thread in the needle. For bobbin thread, “S” twist thread as well as “Z” twist thread can be used.

4) How to route the upper thread (Fig.10, Fig.11):

A Pass each upper thread through thread guide A

Note: when thin slippery thread (polyester thread for example) is used pass the thread through thread guide B as show in Fig.10

B With the take-up lever located at the upper most position, pass each thread in the order in Fig.11.

Note: Pressing the upper thread loosening button, the upper thread can be pulled out easily.

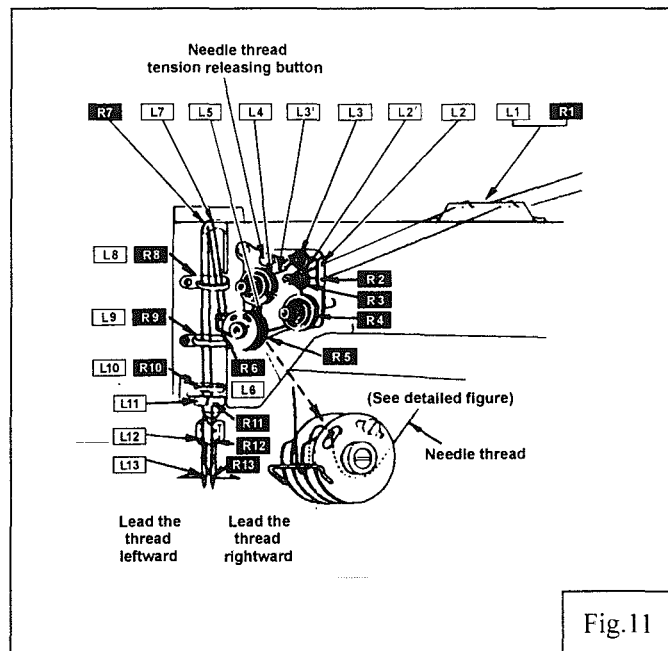
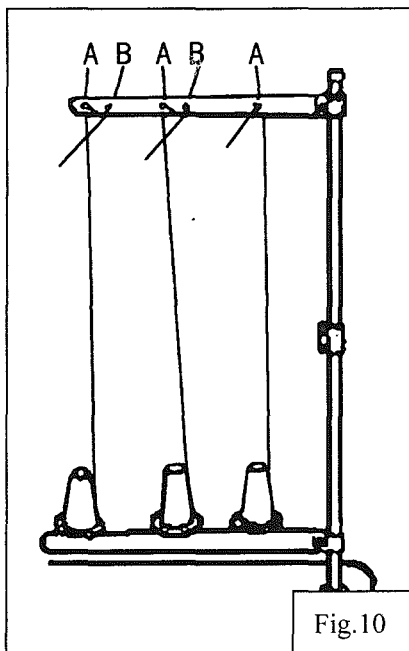

5) Adjustment of stitch length and reverse sewing (Fig.12):

A Rotate the stitch length adjusting dial to change the stitch length

B Pressing the stitch length adjusting lever for reverse stitching.

6) Setting bobbin (Fig.13):

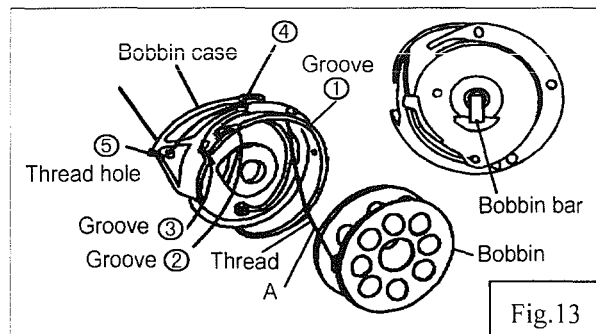
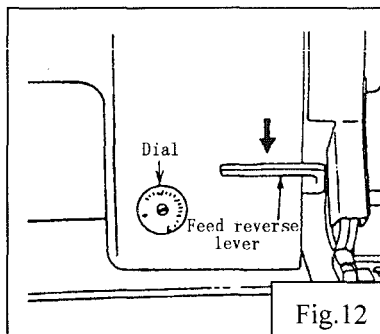

Leading the lower thread and install the bobbin

Pull out thread from side A , then install the bobbin case , Threading following ①~⑤; Put the bobbin case to rotating hook, then replace hook shaft; Press the bobbin bar, leading the lower thread over bedplate.

7) Threading of bobbin threads (Fig.14)

While holding the two needle Threads by left hand, rotate the hand-wheel one turn by right hand. By pulling up the needle threads, as shown in the figure, the bobbin threads will be lifted. Each combination of bobbin thread and needle thread should be aligned and led backward.

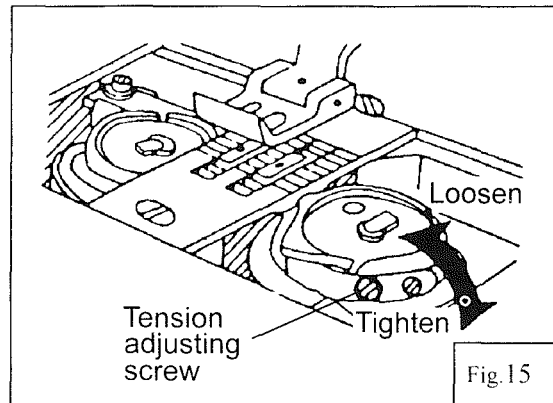
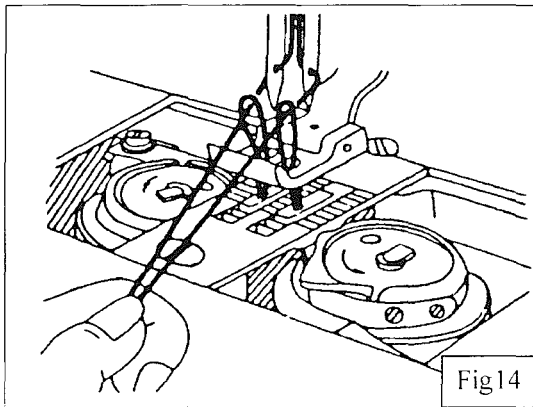

8) Tension adjustment of bobbin threads (Fig.15)

9) Balance of thread tension (Fig.16)

10) Needle thread tension (Fig.17)

Needle thread tension should be adjusted in reference to bobbin thread tension. To adjust needle thread tension, turn

each tension adjusting nut. Needle thread tension can be also adjusted for special fabric and thread by changing intensity and movable range of slack thread adjusting spring.

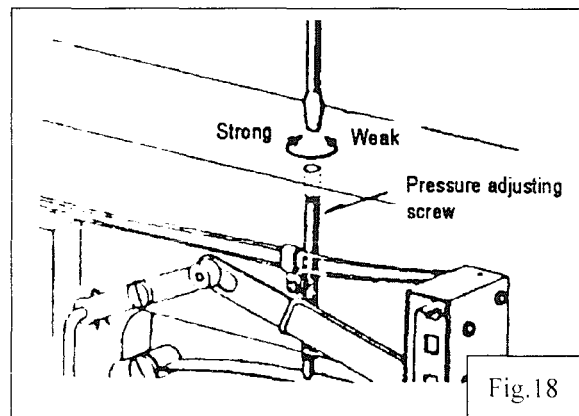
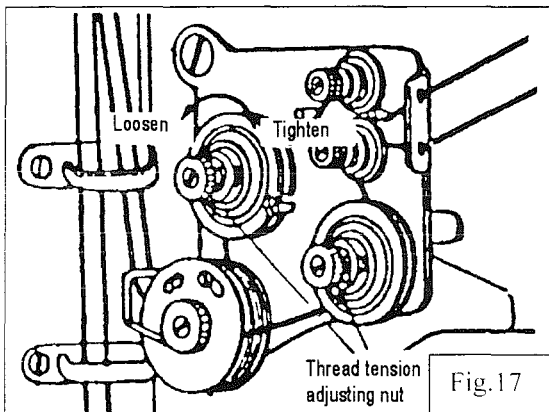
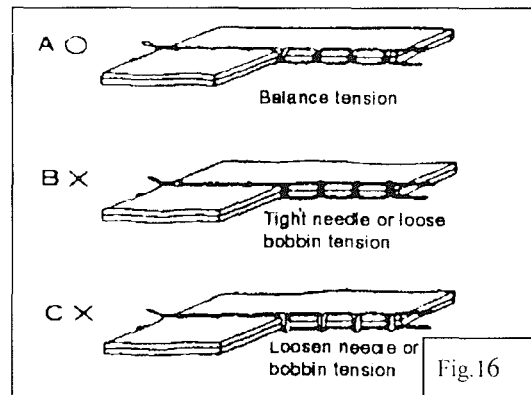

11) Adjustment of pressure of presser foot (Fig.18):

- A Pressure should be adjusted according to the material to be sewn.
- B Turning the pressure adjusting screw to adjust the pressure of presser foot

12) Timing between rotating hook motion and needle motion (Fig.19):

- A Set stitch length to “6”;
- B When needle is lifted 2.4mm from the lower dead point, the following position relationship should be maintained:
 - a. The upper edge of needle eye should be 2.3mm below the hook point
 - b. The hook point should be located at the center of needle axis.
 - c. Gap between the hook point and the side face of needle should be 0.05 mm

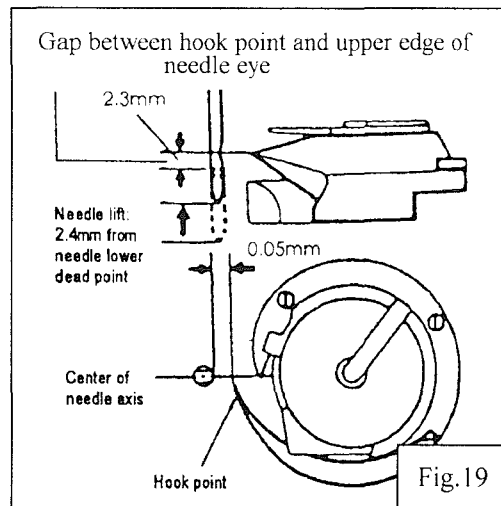

13) Adjustment of Feed dog height (Fig.20):

Height of feed dog should be adjusted for individual fabrics with the following cautions:

- A Fabric will be damaged if the feed dog extends too high or pressure of presser foot is too large
- B Even stitch length cannot be assured if the feed dog is too low or pressure of presser foot is too small
- C Feed dog height should be measured at the point where the needle is at the top position.

For light fabric: Approx 0.8mm
 For usual fabric: Approx 1.0mm
 For heavy fabric: Approx 1.2mm

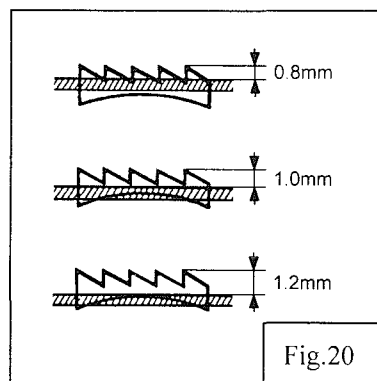

Adjustment procedure:

- A Lay down the machine bed toward the other side;
- B Turn the balance wheel by hand stop when the feed dog is raised to its highest position from the surface of needle plate;
- C Loosen the Screw and adjust the height of the feed dog;
- D After adjusted, tighten the screw.

The feed dog height is factory-adjusted to 1.2mm

14) Adjustment the needle stop position (图 21):

- A Loosen the needle bar Screw A;
- B Rotate the needle clamp B one circuit (amount of Adjustment is 0.6mm), or loosen the needle bar screw C, rotate position screw D

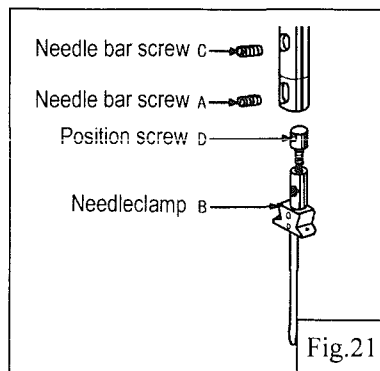

half a circuit (amount of Adjustment is 0.3mm)

C Be sure to make the needle clamp facing left side, tighten needle bar screw C and A

15) Needle bar stop position (left & right) (Fig.19):

- A Stop the motion of left-side needle bar:
Make the stopper wrench to the position L
- B Stop the motion of right-side needle bar:
Make the stopper wrench to the position R
- C Two needles running at the same time:
Return the needle bar of left or right from standstill to running: Press down restore plate, stopper wrench restore to O position automatically

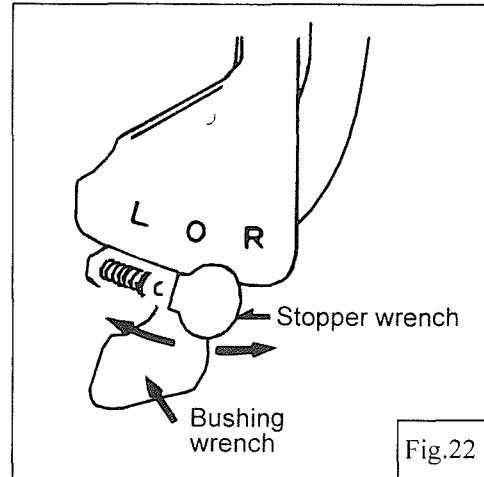

16) Walking foot and presser foot vertical stroke

adjustment (Fig.23):

When fabric with large elasticity is sewn, or when thickness of fabric changes, the vertical stroke (movable range) of the presser feet should be adjusted as follows:

- A Loosen the special bolt;
- B The vertical strokes of presser feet become minimum when the crank rod is moved downward and set;
- C The vertical strokes of presser feet become maximum when the crank rod is moved upward and set;
- D After the adjustment, tighten the special nut.

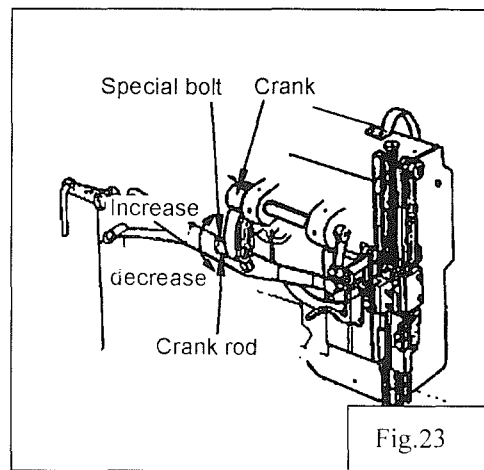

The vertical strokes of presser feet can be adjusted within a range from 2mm to 6mm.

17) Relationship between rotating hook motion and take-up lever motion (Fig.24)

When the timing belt (toothed belt) was removed for its replacement, for example, the relationship between rotating hook motion and take-up lever motion should be adjusted as follows:

- A Turn the balance wheel and stop when the take-up lever is lifted to its upper dead point.
- B Lean the machine head backward and make sure the arrow (timing mark) put on the timing belt is in line with the black line on the boss of lower shaft bearing.
- C If the timing mark is not in line with the black line, remove the timing belt and install it again to adjust.

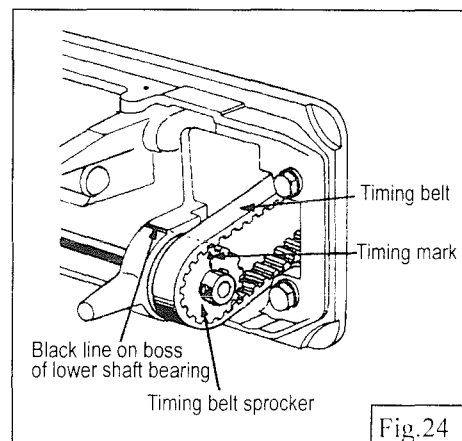

18) Relationship between hook motion and opener motion (Fig.25)

- A Turn the balance wheel by hand and stop when the opener holder is located most remotely from the throat plate.
- B Make sure gap between the bobbin case holder A and the opener is approximately 0.2mm.
- C If the gap is too large or small, loosen the opener holder set screw B and adjust position of the opener.

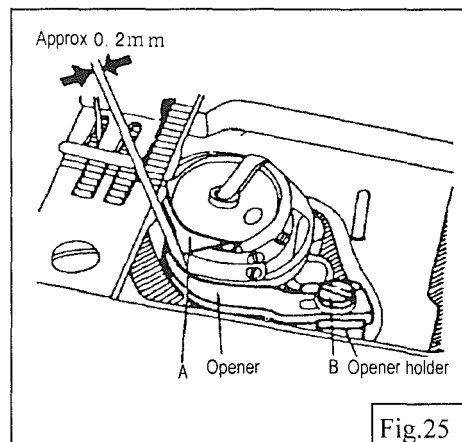

19) Relationship between needle motion and feed dog motion

- A Set feed length to “0” on the feed setting dial
- B Lean the machine head backward. (Fig.26)
- C Loosen the feed lifting rockshaft crank set screws A and B
- D Set the needle at the lowest position. Adjust the distance between presser rod and vibration prevention rod to 9mm and temporarily tighten the feed lifting rockshaft crank set screws A and B.(Fig.27)
- E Check that the right feed lifting rockshaft crank is connected with the link at right angle, as shown in Figure.
- F If the connection is not at right angle, remove the back cover, loosen screw C and move the right link to connect the right feed lifting rock shaft with the link at right angle.(Fig.28)
- G After the completion of adjustment, fully tighten the screws A , B and C.
- ♦ At this time make certain that needle can enter the feed dog needle hole at the center of the hole.

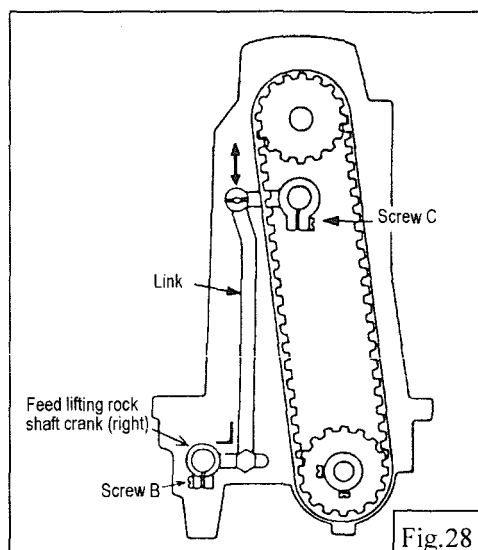
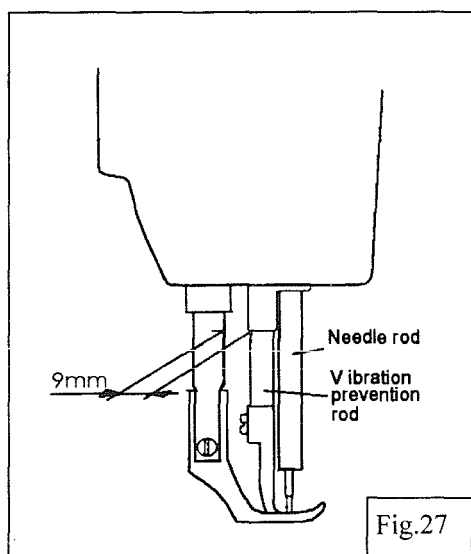
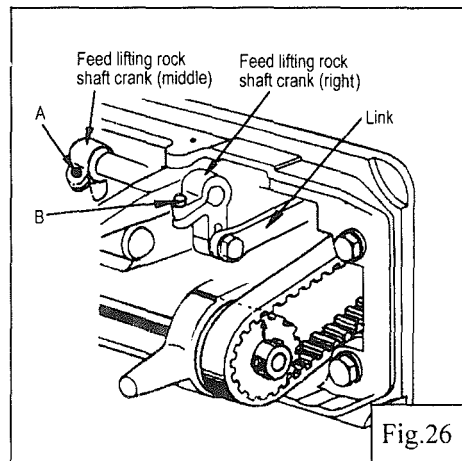

20) Safety clutch device (Fig.21, Fig.22) :

Safety clutch device is installed to prevent the hook and cog belt from damage in case the thread is caught into the hook when the machine is loaded abnormally operation.

A Function of safety clutch:

- When the safety clutch acts, the cog belt pulley will be unloaded. Then the rotation of hook shaft will stop. The arm shaft only will rotate. Stop the operation of machine.
- Clean the thread thoroughly which is caught into the hook.
- Turn the cog belt hub by hand, and check whether the hook shaft rotates lightly and properly, place the clutch device as follows.

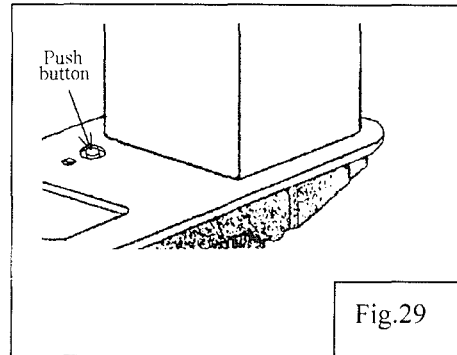

B How to set the safety clutch (Fig.29)

- While pressing down the push button on the opposite side of bed by left hand, turn the balance wheel slowly by right hand away from you;
- The balance wheel will stop by the gear plate, but turn the balance wheel more firmly;
- Release the push button, the safety clutch device is set.

C Force applied to the safety clutch (Fig.30)

- The force applied to the safety clutch is the smallest when the mark of eccentric pin faces the center of the lower shaft. The force proportionally increases as the mark faces the outside;
- To adjust the force slide the timing belt, loosen the set screw, and turn the eccentric pin;
- After the adjustment, tighten the set screw.

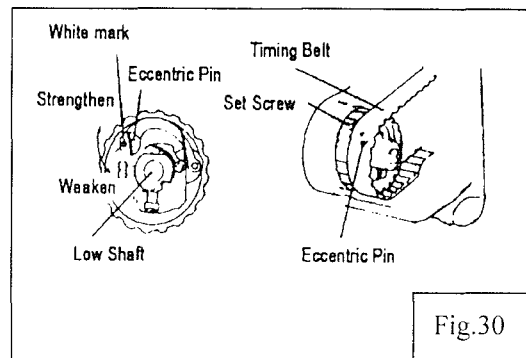

21) Adjustment

Screwing the pin that connects the link of back-sewing with the crank of back-sewing (down) can adjust the tolerance of between the stitches. Screwing the pin in clockwise can increase the stitch of forward sewing; otherwise, the stitch of back-sewing will be increased.

22) Installation of movable knife

A Installation of movable knife (Fig.31)

- Turn the balance wheel and lower the needle bar to the lowest position.
- Push the cam follower crank so that the cam roller enters into the thread trimmer cam groove.
- Turn the balance wheel until the black mark point on the arm meets the white mark point on the

balance wheel. Set the cam follower crank at this position with a screwdriver temporarily preventing the cam roller coming out from the cam groove.

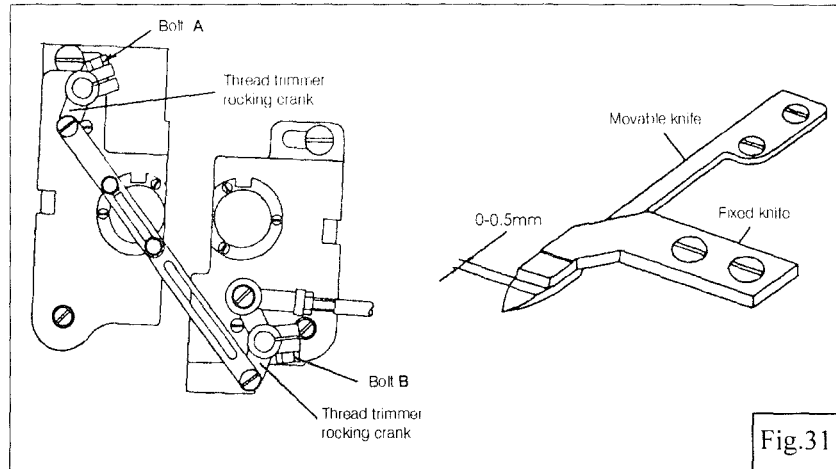

- d. Loosen the thread trimmer rocking crank clamp bolts A and B.
- e. Adjust the movable knife so that the movable knife end slant portion protrudes 0-0.5 mm from the fixed knife, as shown in Figure and tighten the bolts A and B.

B Gap between movable knife and bobbin case holder stopper (Fig.32)

- a. Turn the balance wheel by hand until needle reaches the Lowest position.
- b. With the needle at the lowest position, depress cam follower crank, turn the balance wheel until the movable knife reaches the extremity of its stroke.
- c. Manually rotate the inner hook in the direction indicated by arrow in Figure and adjust gap between the movable knife and the inner hook stopper to about 0.5 mm (the screws A and B should be loosened for this adjustment).

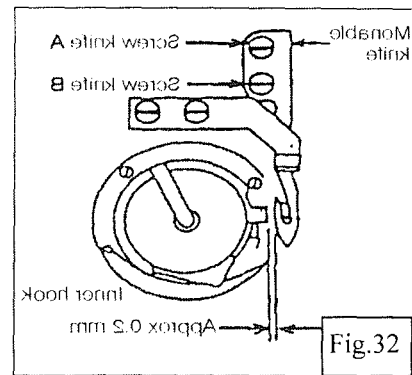

23) Adjustment of thread trimmer cam

- A Turn the balance wheel by hand until the needles reach the lowest position.
- B Maintaining the needle position, depress the cam follower crank and put the cam roller into the groove of thread trimmer cam.
- C Turning the balance wheel by hand, adjust

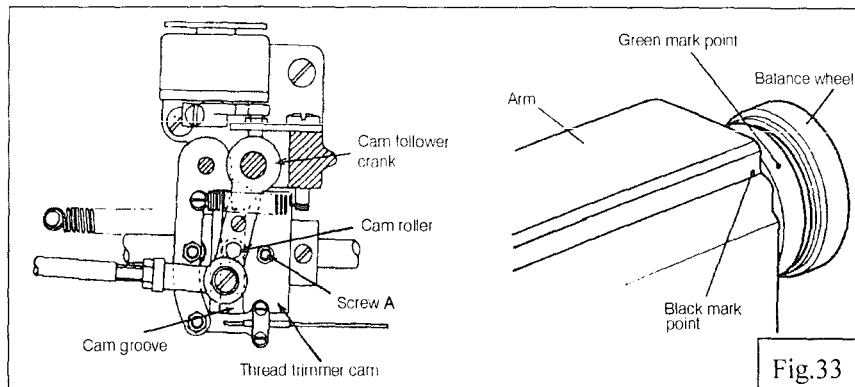

the thread trimmer cam so that the movable knife starts moving when the green mark point on the balance wheel comes in line with the black mark point on the arm.

Note: To adjust, Loosen two thread trimmer cam clamp screws A.

24) Adjustment of needle threads tension release assembly (Fig.34)

- A Turn the balance wheel by hand until the needles reach the lowest position.
- B Maintaining the needle position, depress the cam follower crank and put the cam roller into the groove of thread trimmer cam.
- C Turning the balance wheel by hand, adjust the thread tension release cam so that the tension disc close when the white mark point on the balance wheel comes in line with the black mark point on the arm.
- D To adjust, loosen two tension release cam clamp screws A.
- E Opening degree of tension disc should be adjusted with the tension release roller B mounted on the convex portion of thread release cam, as shown in Fig. To adjust, loosen the screws C and draw the wire.
- F Make fine adjustment by loosening the nut D.
- G Loosen the nut D and make the outer casing approach rightward to increase the opening value.

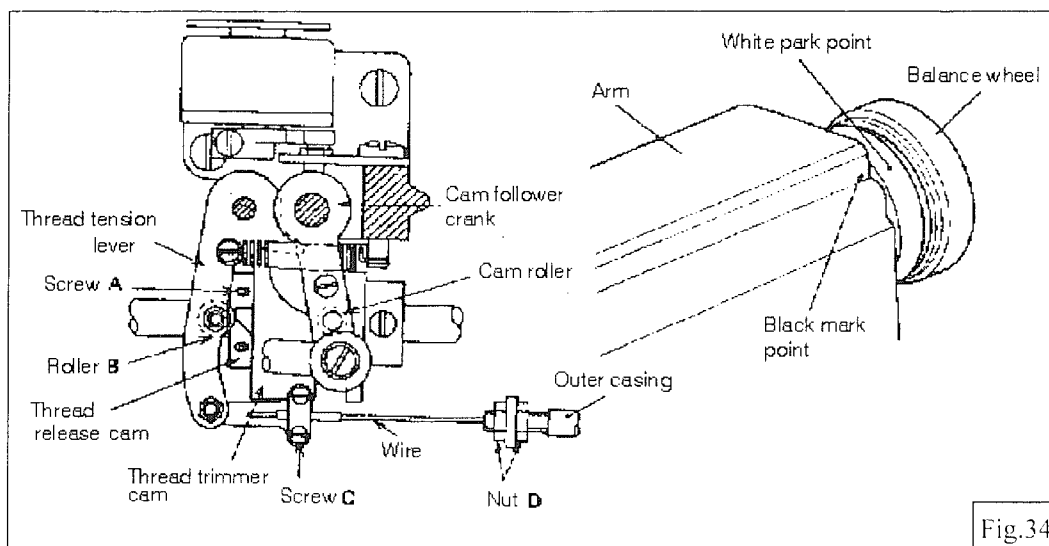

25) Adjustment of scissoring pressure of movable knife and fixed knife (Fig.35)

- A Loosen the fixed knife bracket clamp bolt A.
- B Turn the vertical position adjusting screw B to adjust meshing pressure and then tighten the hexagon socket head cap screw A.

Note: Since excess pressure causes large torque to the thread trimming mechanism and trimming failure, adjust it so

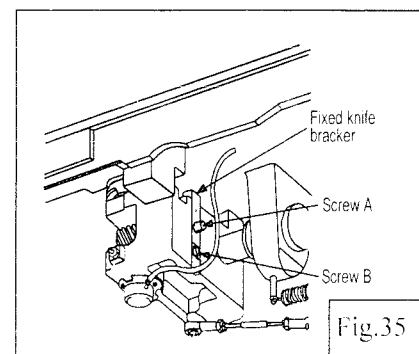

that thread can be trimmed with minimum pressure.

- C Move the movable knife and check that the thread can be sharply trimmed.

26) Sharpening of fixed knife

When the knives dull, the fixed should be sharpened as illustrated in Fig. Since it is very difficult to sharpen the movable knife, replace it with a new one when it dulls (Fig.36).

27) Adjustment for change of needle-to-needle distance (Fig.37)

- A Replace the throat plate, feed dog and needle clamp. (Since the throat plate and feed dog are special parts designed for thread trimming machine, be sure to use those specified by us.)

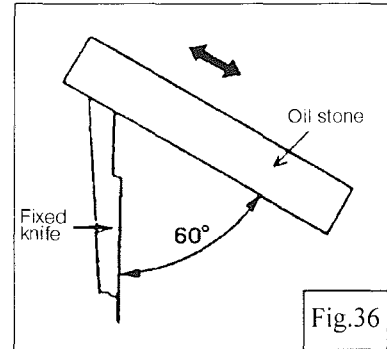

- B Lean the machine head backward.
- C Loosen two connecting link clamp bolts J.
- D Remove the spring M.
- E Loosen the hook bracket clamp screws A and B and adjust gap

between each needle and hook.

- F When the needles and hooks have been adjusted, install the spring M.

- G Contact the rocking cranks C and D to the stopper pins E and F and tighten the connecting link clamp bolt J.

- H Turn the balance wheel by band until the needles reach the lowest position.

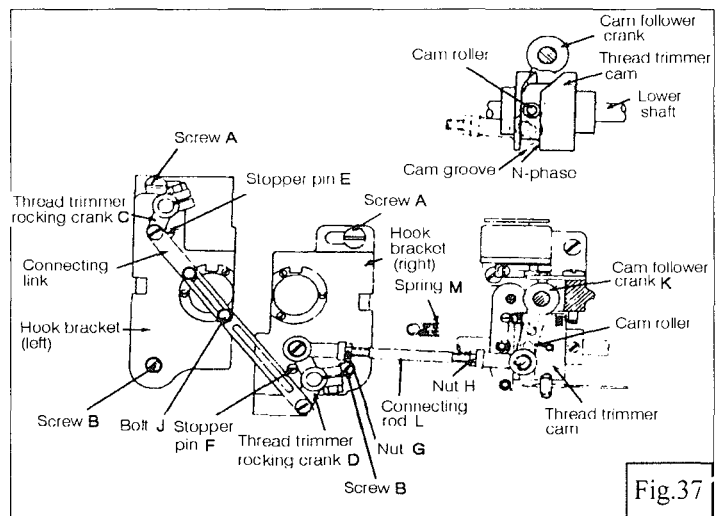

- I Loosen the nuts G and H.

- J Depress the cam follower crank K and adjust the connecting rod L so that the cam roller can smoothly enter the groove of thread trimmer cam.

Adjustment of the cam groove and the cam roller

- A Push the cam follower crank K so that the cam roller enters into the cam groove.
- B Turn the connecting rod L and adjust the clearance between the cam roller and the cam groove surface L as small as possible, and tighten the nuts G and H.
- C Push the cam follower crank K again and check that the cam roller enters into the thread trimmer cam groove smoothly.

A. ARM BED AND ITS ACCESSORIES

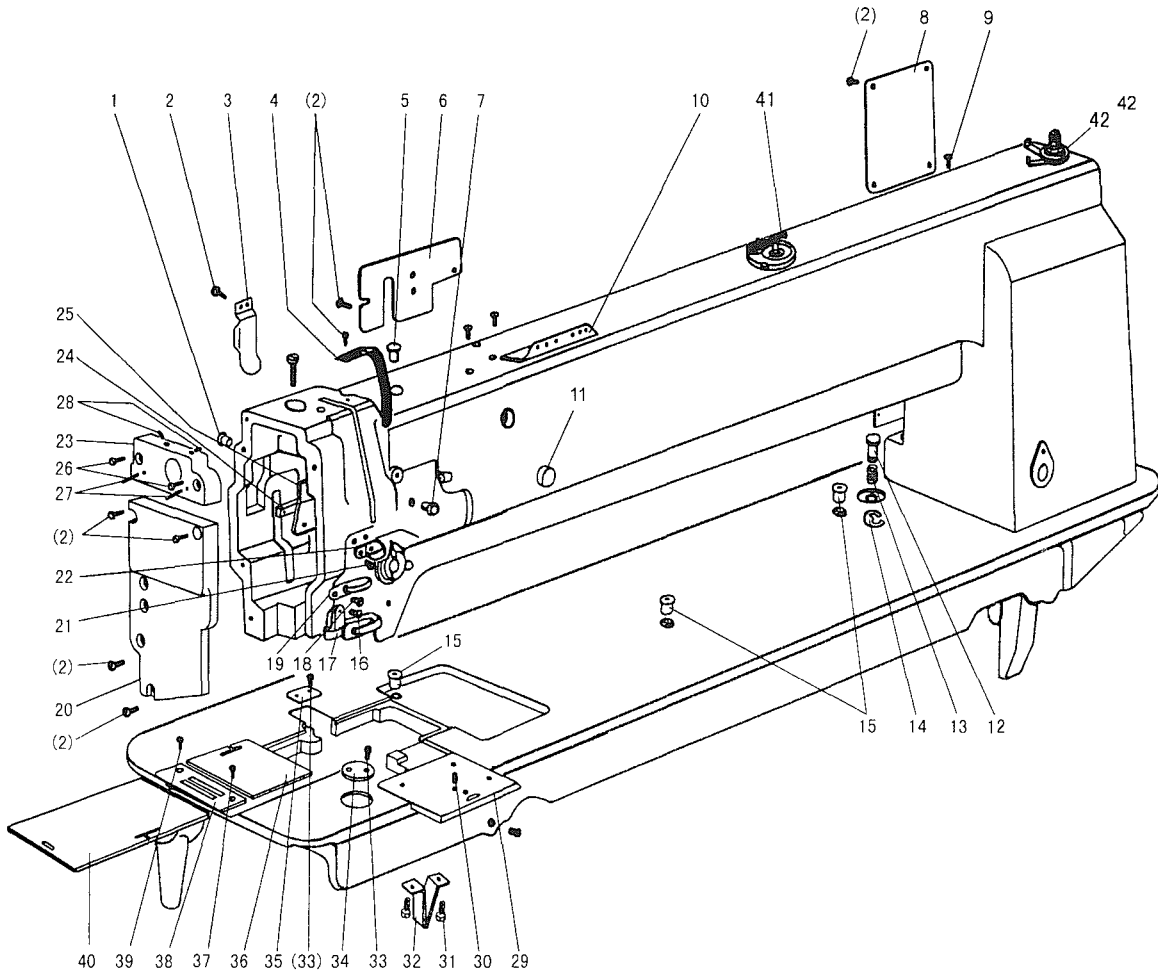

From the library of: Diamond Needle Corp

A.ARM BED AND ITS ACCESSORIES

Fig. No.	Part No.	Description	GC20638-25	GC20638-25D	Remarks
A01	HA300B2090	Rubber plug	2	2	
A02	HA300B2170	Screw	15	15	SM11/64 (40) ×9
A03	H4716B8001	Oil guide plate	1	1	
A04	H4717B8001	Thread take-up cover	1	1	
A05	H4715B8001	Rubber plug	1	1	
A06	H4718B8001	Arm side cover (left)	1	1	
A07	H2000B2010	Rubber plug	1	1	
A08	H4719B8001	Arm side cover (right)	1	1	
A08	H4919B8001	Side cover (right)	1	1	
A09	HA700B2060	Screw	2	2	SM11/64 (40) ×8
A10	H2400B2100	Thread guide	1	1	
A11	HA307B0673	Rubber plug	1	1	
A12	H4715H8001	Push button	1	1	
A13	H4714H8001	Spring	1	1	
A14	H007013050	E-type ring	1	1	
A15	H2000M0090	Cap	3	3	
A16	H3200B2100	Screw	1	1	SM9/64 (40) ×6.5
A17	H3212B0066	Thread guide	1	1	
A18	H3000D2160	Screw	1	1	SM9/64 (40) ×4.5
A19	H4726B8001	Thread guide	1	1	
A20	H0213B8001	Face plate	1	1	
A21	H2400B2080	Screw	2	2	SM3/16 (28) ×12.1
A22	H2400B2070	Thread guide	1	1	
A23	H0212B8001	Shaft supporter	1	1	
A24	H2400B2060	Spacer	1	1	
A25	H3200B2060	Oil guide plate	1	1	
A26	HA7311C606	Screw	2	2	SM11/64(40)×15
A27	H602030200	Pin	2	2	A
A28	HA100B2110	Screw	2	2	SM11/64(40)×5.5
A29	H3219B0067	Slide plate complete		1	
A30	H3200B2170	Screw		1	SM13/64 (32) ×4.8
A31	H4912B8001	Screw		2	SM1/4 (24) ×9
A32	H4913B8001	Supporter		1	
A33	H4914B8001	Screw		4	SM9/64 (40) ×6
A34	H4915B8001	Cover		1	
A35	H4911B8001	Cover	1	1	
A36	H4733B8001	Slide plate(right)	1	1	
A37	HA300B2190	Screw	1	1	SM11/64 (40) ×8
A38	H4740B8001	Needle plate	1		
A38	H4741B8001	Needle plate	1		
A38	H4940B8001	Needle plate		1	
A38	H4941B8001	Needle plate		1	
A39	H3200B2120	Screw	1	1	SM9/64 (36) ×6.5

A.ARM BED AND ITS ACCESSORIES

Fig. No.	Part No.	Description	GC20638-25	GC20638-25D	Remarks
A40	H4746B8001	Slide plate(left)	1	1	
A41	H7007D7101	Bobbin winder	1	1	
A42	H7014D7101	Down-lead complete	1	1	

B. THREAD TENSION REGULATOR MECHANISM

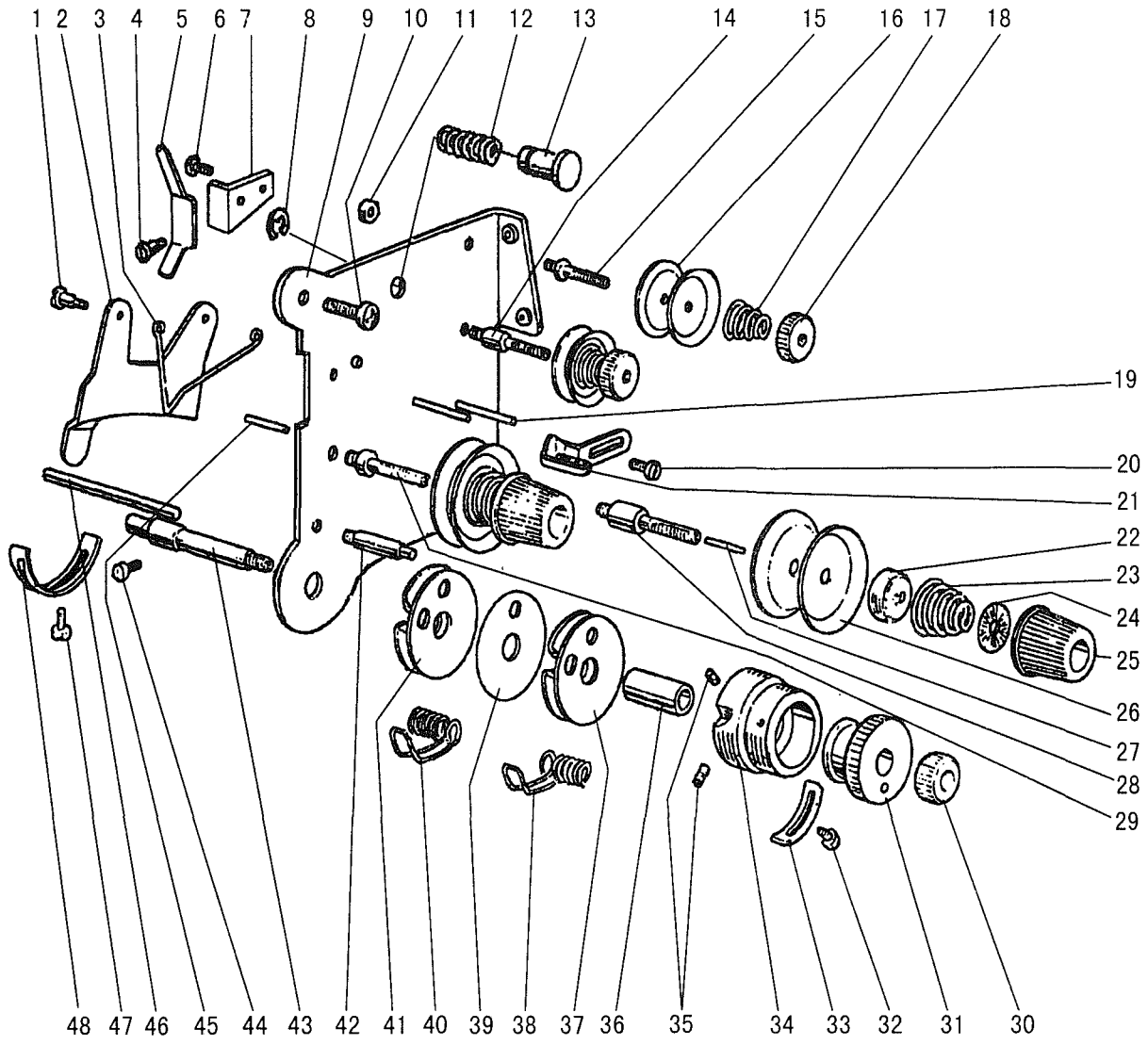

From the library of: Diamond Needle Corp

B. THREAD TENSION REGULATOR MECHANISM

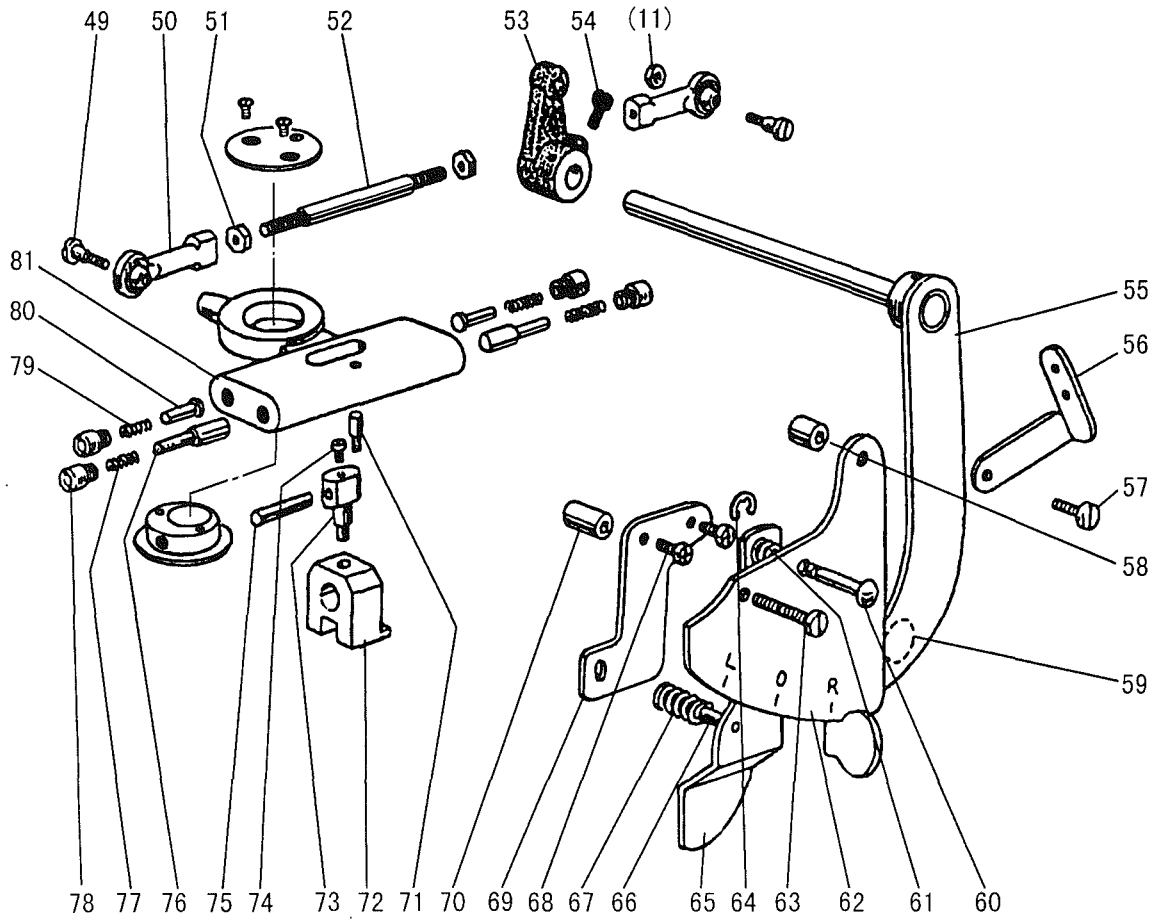

B.THREAD TENSION REGULATOR MECHANISM

Fig. No.	Part No.	Description	GC20638-25	GC20638-25D	Remarks
B01	H2504C6510	Screw	2	2	SM9/64 (40) ×3
B02	H3221B3142	Tension releasing plate	1	1	
B03	H3221B6812	Tension releasing spring	1	1	
B04	H4705C8001	Screw	1	1	SM9/64 (40) ×5.5
B05	H4706C8001	Lever	1	1	
B06	HA7311C306	Screw	1	1	SM9/64 (40) ×7
B07	H4707C8001	Mounting plate	1	1	
B08	H007013050	E-type ring	1	1	
B09	H3221B6820	Mounting plate	1	1	
B10	HA300C2030	Screw	2	2	SM11/64 (40) ×8
B11	H3221B6810	Nut	2	2	
B12	H4708C8001	Spring	1	1	
B13	H4709C8001	Push button	1	1	
B14	H3221B0685	Thread tension stud	1	1	SM11/64 (40) ×14
B15	H3221B0683	Thread tension stud	1	1	SM11/64 (40) ×14
B16	HA112B0693	Thread tension disc	4	4	
B17	H3300B2040	Spring	2	2	
B18	HA710B0671	Thumb nut	2	2	
B19	H3221B0682	Pin	3	3	
B20	HA106B0676	Screw	1	1	SM9/64 (40) ×6
B21	H3306B0661	Thread guide	1	1	
B22	HA310B0702	Tension releasing disc	2	2	
B23	H4710C8001	Spring	2	2	
B24	HA115B7010	Thumb nut revolution stopper	2	2	
B25	HA310B0701	Thumb nut	2	2	
B26	HA310B0705	Thread tension disc	4	4	
B27	H3221B6816	Pin	1	1	
B28	H3221B0689	Thread tension stud	1	1	SM1/4 (40) ×23
B29	H3221B0686	Thread tension stud	1	1	SM1/4 (40) ×23
B30	H32481B721	Thumb nut	1	1	
B31	H32481B621	Take-up spring guide	1	1	
B32	H32481BC21	Screw	1	1	SM9/64 (40) ×6
B33	H32481BB21	Stopper	1	1	
B34	H32481B921	Thread tension post	1	1	
B35	H32481B521	Screw	2	2	SM1/8 (44) ×3.9
B36	H32481B821	Bushing	1	1	
B37	H32481BF21	Plate complete	1	1	
B38	H4712C8001	Thread take-up spring	1	1	
B39	H32481BE21	Plate complete	1	1	
B40	H4713C8001	Thread take-up spring	1	1	
B41	H32481BD21	Plate complete	1	1	
B42	H32481B421	Thread tension stud	1	1	SM9/64 (40) ×2.9
B43	H32481B121	Thread tension stud	1	1	SM1/4 (40) ×38.5

B.THREAD TENSION REGULATOR MECHANISM

Fig. No.	Part No.	Description	GC20638-25	GC20638-25D	Remarks
B44	H3230K0751	Screw	1	1	SM11/64 (40) ×10
B45	H3221B6817	Pin	1	1	
B46	H4769E8001	Pin	1	1	
B47	H3200B2100	Screw	1	1	SM9/64 (40) ×6.5
B48	H3221B6819	Stopper	1	1	
B49	H3400D2030	Screw	2	2	SM11/64(40)×9.5
B50	H3405D0663	Link	2	2	JKM5
B51	H003057050	Nut	2	2	M5
B52	H3405D0661	Screw bar	1	1	
B53	H0207C8001	Crank	1	1	
B54	HE512D8001	Screw	1	1	SM11/64 (32) ×12
B55	H0204C7101	Stop motion control lever complete	1	1	
B56	H3400L0050	Thread guide	1	1	
B57	HA7311C606	Screw	1	1	SM11/64(40)×15
B58	H3400D2060	Cannulation	1	1	L=7.7
B59	H3407D0671	Pin	1	1	
B60	H3408D0681	Pin	1	1	
B61	H3408D0682	Spring	1	1	
B62	H3408D0686	Tension bracket	1	1	
B63	H0210C8001	Screw	1	1	SM11/64(40)×22
B64	H007013040	E-type ring	1	1	GB/T896 4
B65	H3408D0684	Lever	1	1	
B66	H3408D0685	Pin	1	1	
B67	H3400D2100	Spring	1	1	
B68	HA300C2030	Screw	2	2	SM11/64(40)×8
B69	H0208C8001	Plate	1	1	
B70	H0209C8001	Cannulation	1	1	L=15.2
B71	H3400D2110	Screw	1	1	SM9/64(40)×5
B72	H3210C3021	Crank	1	1	
B73	H3404D0652	Pin	1	1	
B74	HA7311CC06	Screw	1	1	SM9/64 (40) ×6.5
B75	H3404D0653	Pin	1	1	
B76	H3404D0655	Pin	2	2	
B77	H3404D0657	Spring	2	2	
B78	H3404D0656	Screw	4	4	SM5/16 (28) ×4
B79	H3404D0658	Spring	2	2	
B80	H3404D0654	Pin	2	2	
B81	H3404D0651	Guide	1	1	

C. ARM SHAFT MECHANISM

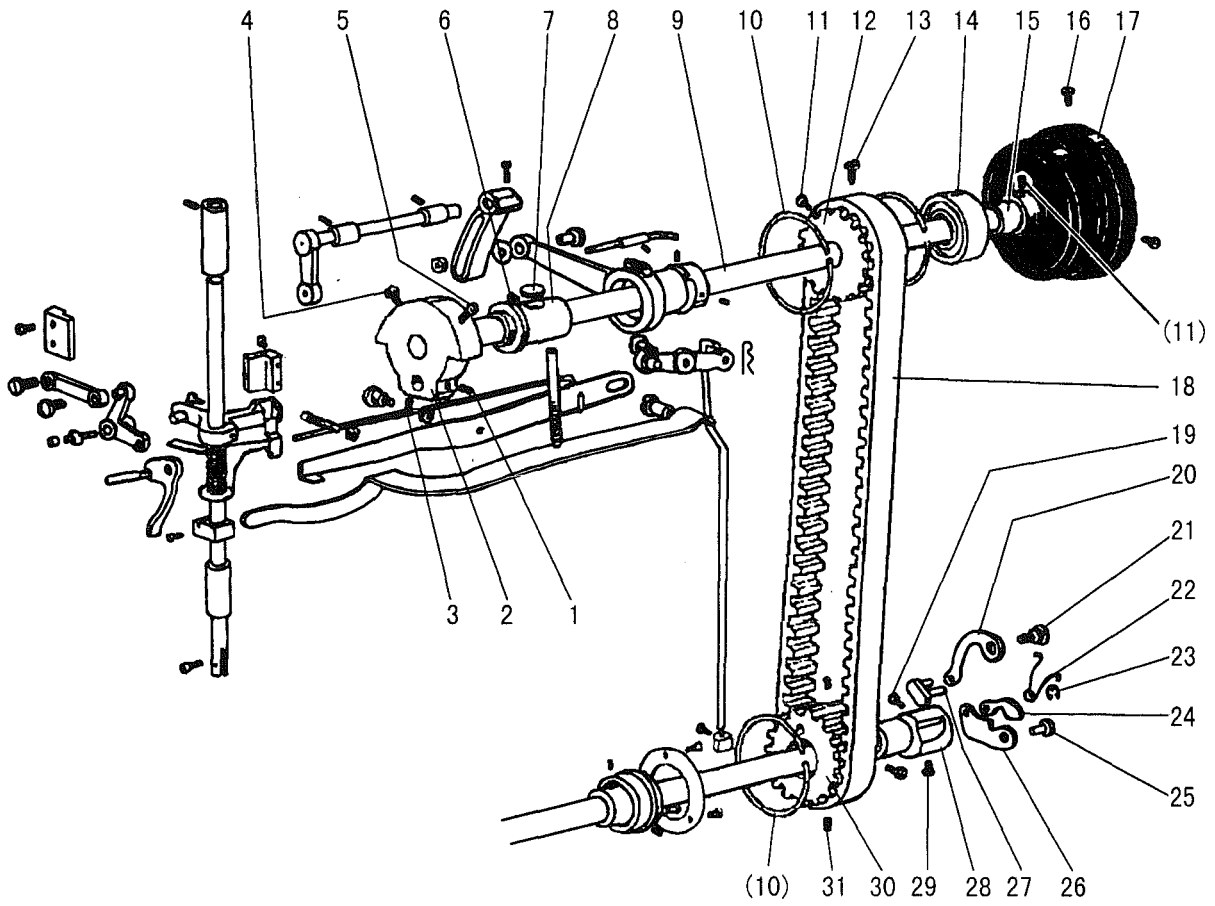

From the library of: Diamond Needle Corp

C.ARM SHAFT MECHANISM

Fig. No.	Part No.	Description	GC20638-25	GC20638-25D	Remarks
C01	HA307C0662	Set screw	1	1	SM1/4 (40) ×6
C02	H3404B0011	Crank	1	1	
C03	HA105D0662	Set screw	1	1	SM1/4 (40) ×4
C04	HA100C2060	Screw	1	1	SM9/32 (28) ×13
C05	HA100C2070	Screw	1	1	SM9/32 (28) ×14
C06	H4708D8001	Set screw	1	1	SM1/4(24)×13
C07	H32111B104	Felt	1	1	
C08	H32111B204	Arm shaft bushing (left)	1	1	
C09	H4709D8001	Arm shaft	1	1	
C10	H3205C0661	Spring flange	3	3	
C11	HA113F0684	Screw	3	3	SM15/64 (28) ×8.5
C12	H3205C1021	Pulley	1	1	
C13	HA100F2130	Screw	1	1	SM15/64 (28) ×14.5
C14	H3205J0662	Bearing	1	1	
C15	H3205J0661	Collar	1	1	
C16	HA110D0672	Screw	2		SM15/64 (28) ×12
C17	H4100C2040	Pulley	1		
C18	H3200C2030	Cog belt	1	1	
C19	HA104F0654	Screw	1	1	SM15/64 (28) ×10
C20	H4713D8001	Link	1	1	
C21	H4714D8001	Pin	1	1	
C22	H4716D8001	Spring	1	1	
C23	H007013025	E-type ring	1	1	
C24	H4717D8001	Link	1	1	
C25	H4718D8001	Pin	1	1	
C26	H4719D8001	Link	1	1	
C27	H4715D8001	Pin	1	1	
C28	H4720D8001	Bushing	1	1	
C29	H4721D8001	Screw	1	1	SM15/64(28)×10.5
C30	H4722D8001	Pulley	1	1	
C31	H4723D8001	Screw	2	2	SM15/64(28)×4.5

D. UPPER SHAFT & PRESSER FOOT MECHANISM

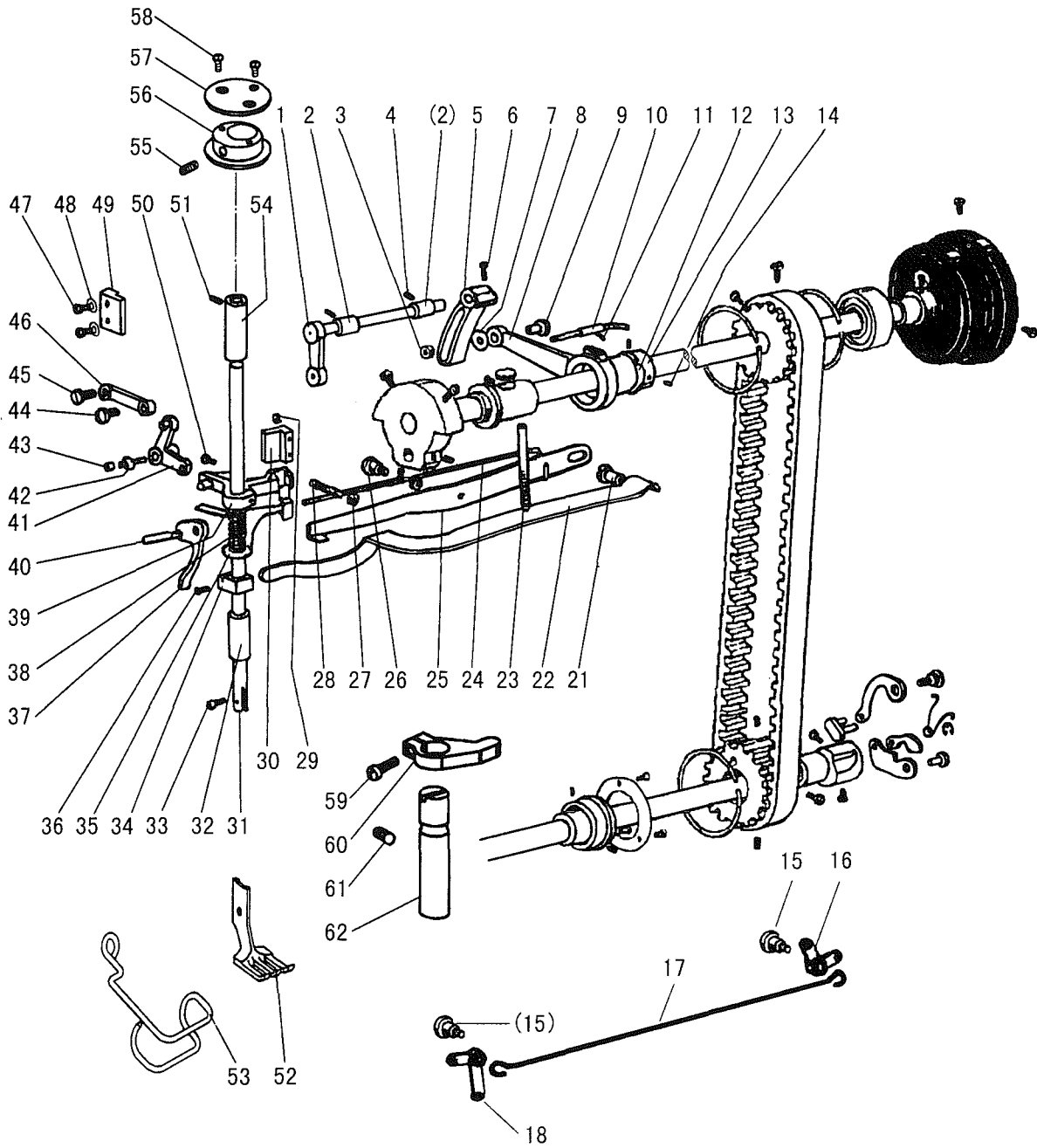

From the library of: Diamond Needle Corp

D.UPPER SHAFT & PRESSER FOOT MECHANISM

Fig. No.	Part No.	Description	GC20638-25	GC20638-25D	Remarks
D01	H4705E8001	Feed lifting rock shaft	1	1	
D02	H4707E8001	Bushing	2	2	
D03	H0030550608	Nut	1	1	(M6×0.75)
D04	H4706E8001	Set screw	2	2	SM1/4 (24)×7
D05	H4709E8001	Crank	1	1	
D06	H3115F0671	Screw	1	1	SM1/4 (28) ×16
D07	H2013J0065	Washer	1	1	
D08	H2014J0066	Connecting rod	1	1	
D09	H2000J2100	Screw	1	1	M6(0.75)×24
D10	H4713E8001	Oil wick	1	1	
D11	H20111C106	Holder	1	1	
D12	H007009250	C-type ring	1	1	
D13	H4714E8001	Eccentric	1	1	
D14	HA307C0662	Screw	2	2	SM1/4 (40) ×6
D15	H7008E8001	Screw	2	2	SM1/4 (24) ×14
D16	H7009E8001	Plate (B)	1	1	
D17	H7007E8001	Plate	1	1	
D18	H7005E8001	Plate (A)	1	1	
D21	H3100G2170	Screw	1	1	SM1/4 (24) ×17
D22	H4730E8001	Lever spring	1	1	
D23	H4729E8001	Screw	1	1	SM15/64 (28) ×79
D24	H4727E8001	Twist spring	1	1	
D25	H4728E8001	Knee lifting lever	1	1	
D26	H3100G2130	Screw	1	1	SM1/4 (24) ×7
D27	H4726E8001	Nut	1	1	
D28	H4725E8001	Screw	1	1	SM1/4 (24) ×19
D29	HA111G0683	Screw	2	2	SM11/64(40)×12
D30	H4723E8001	Guide	1	1	
D31	H4754E8001	Presser bar	1	1	
D32	H4744E8001	Bushing	1	1	
D33	H3200E2020	Screw	1	1	SM1/8(44)×9
D34	H4746E8001	Spring bracket	1	1	
D35	H4768E8001	Thread releasing plate	1		
D36	H2404I0034	Screw	1	1	SM9/64 (40) ×8.5
D37	H4748E8001	Lift lever	1	1	
D38	H4767E8001	Spring	1		
D39	H4752E8001	Bracket	1	1	
D40	H4749E8001	Screw	1	1	SM11/64 (40) ×8.5
D41	H0207E8001	Bell crank	1	1	
D42	H2004J0655	Screw	1	1	SM3/16 (28) ×10
D43	H4717E8001	Roller	1	1	
D44	H4718E8001	Screw	1	1	SM11/64(32)×6
D45	H2004J0662	Screw	1	1	SM1/4(40)×5

D. UPPER SHAFT & PRESSER FOOT MECHANISM

Fig. No.	Part No.	Description	GC20638-25	GC20638-25D	Remarks
D46	H4719E8001	Link	1	1	
D47	HA100E2150	Screw	2	2	SM11/64 (40) ×10
D48	H4722E8001	Washer	2	2	
D49	H4721E8001	Bell crank guide	1	1	
D50	H4753E8001	Screw	1	1	SM11/64 (40) ×17.5
D51	H4708D8001	Set screw	2	2	SM1/4(24)×13
D52	HE504D8001	Lifting presser	1	1	5/16
D52	HE304E8001	Lifting presser	1	1	3/8
D53	HE013N8001	Finger gusrd	1	1	
D54	H0205E8001	Bushing	1	1	
D55	H3210F0681	Screw	1	1	M5×6
D56	HE510D8001	Bushing	1	1	
D57	HE511D8001	Cover	1	1	
D58	HE106F8001	Screw	2	2	SM1/8(44)×6
D59	HE512D8001	Screw	1	1	
D60	HE507D8001	Crank	1	1	
D61	H4708D8001	Screw	1	1	SM1/4(24)×13
D62	H0206E8001	Presser bar position guide	1	1	

E. TAKE-UP THREAD AND ARM SHAFT MECHANISM

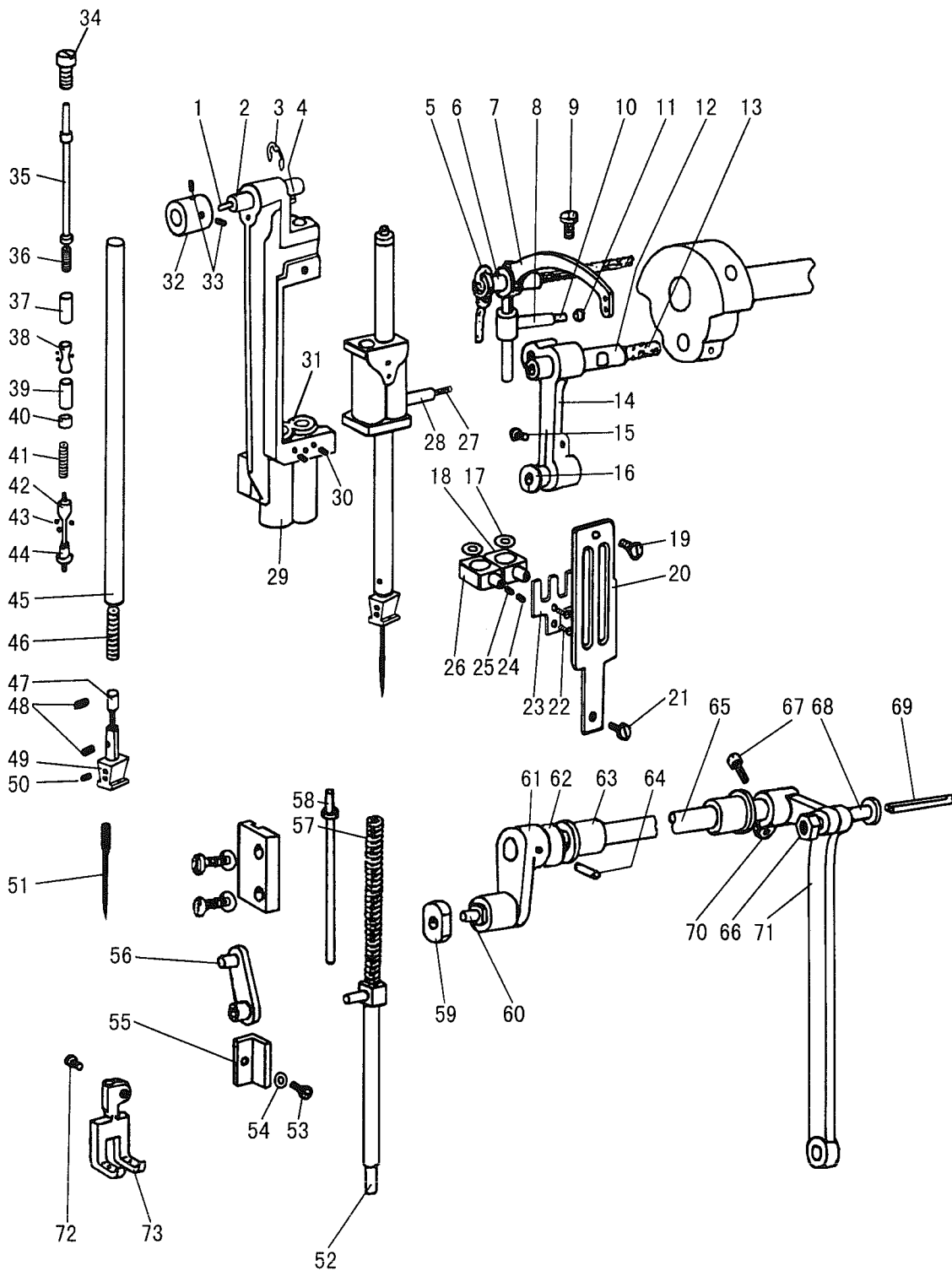

From the library of: Diamond Needle Corp

E.TAKE-UP THREAD AND ARM SHAFT MECHANISM

Fig. No.	Part No.	Description	GC20638-25	GC20638-25D	Remarks
E01	H3410C3023	Oil wick	1	1	
E02	H3410C3022	Shaft	1	1	
E03	H007013070	E-type ring	1	1	GB/T896 7
E04	H609030220	Pin	1	1	GB/T879.1 3×22
E05	H24211DN05	Oil wick	1	1	
E06	H24211DM05	Shaft	1	1	
E07	HE033C8001	Thread take-up lever	1	1	
E08	HE034C8001	Thread take-up slide brock	1	1	
E09	HA110D0672	Screw	1	1	SM15/64(28)×12
E10	H24211D405	Oil wick	1	1	
E11	H24211D305	Plug	1	1	
E12	H2405D0662	Needle bar crank pin	1	1	
E13	H4716F8001	Oil wick	1	1	
E14	H3409C0671	Needle bar connecting link	1	1	
E15	HA100H2050	Screw	1	1	SM9/64(40)×11
E16	H3409C0672	Bushing	1	1	
E17	H3410C3016	Washer	4	4	
E18	H3410C3015	Needle bar holder	1	1	
E19	H3410C301K	Screw	1	1	SM9/64(40)×6.5
E20	HE523E8001	Guide plate	1	1	
E21	HA7121N304	Screw	1	1	
E22	H3410C301C	Screw	1	1	SM3/32(56)×4.2
E23	H3410C301B	Needle bar supporter	1	1	
E24	H3410C3019	Screw	1	1	SM9/64(40)×3.5
E25	H3410C3018	Needle bar holding stopper	1	1	
E26	H3410C3017	Needle bar holder	1	1	
E27	H3204D6513	Felt	1	1	
E28	H3410C3014	Needle bar holder	1	1	
E29	HE505E8001	Needle bar rock frame	1	1	
E30	H34411C410	Screw	2	2	SM9/64(40)×4
E31	H34411C310	Bashing for needle bar supporter	2	2	
E32	H3410C3025	Bashing	1	1	
E33	HA605E0662	Screw	2	2	
E34	H34412C810	Screw	2	2	M5.5×5
E35	H34412C510	Pin	2	2	
E36	H34412C110	Spring	2	2	
E37	H34412C210	Sleeve	2	2	
E38	H34412C310	Pin	2	2	
E39	H3410C1261	Nut	2	2	SM5/64(64)×6
E40	H3410C1262	Nut	2	2	SM5/64(64)×2
E41	H3410C1265	Spring	2	2	
E42	H3410C1263	Stud	2	2	
E43	H3410C301I	Steel ball	12	12	

E.TAKE-UP THREAD AND ARM SHAFT MECHANISM

Fig. No.	Part No.	Description	GC20638-25	GC20638-25D	Remarks
E44	H3410C1264	Triangle pin	2	2	SM5/64(64)×8
E45	HH807F8001	Needle bar	2	2	
E46	H34412C410	Spring	2	2	
E47	HH808F8001	Stopper for needle clamp	2	2	
E48	H34412C710	Screw	4	4	SM1/8(44)×6
E49	HE516E8001	Needle clamp	2	2	5/16
E49	HE524E8001	Needle clamp	2	2	3/8
E50	H32481B521	Screw	2	2	
E51	H4740F8001	Needle	2	2	
E52	HE505D8001	Vibrating presser bar	1	1	
E53	H3400C2020	Bolt	1	1	SM11/64(40)×12
E54	H3200I2030	Washer	1	1	
E55	H3400C2010	Needle bar guide	1	1	
E56	H0206F8001	Vibrating presser bar link	1	1	
E57	H3100F2060	Spring	1	1	
E58	HE506D7101	Vibrating presser spring guide	1	1	
E59	H3410C301P	Square block	1	1	
E60	H3406C0671	Screw	1	1	SM15/64(28)×10
E61	H3406C0672	Needle bar vibrating crank(left)	1	1	
E62	H3400C2050	Washer	1	1	
E63	H3204B0652	Bushing	2	2	
E64	H602040200	Taper pin	1	1	GB/T117 4X20
E65	H7004F8001	Needle bar vibrating shaft	1	1	
E66	H32311D506	Nut	1	1	
E67	H2012N0652	Screw	1	1	
E68	H32311D306	Screw	1	1	
E69	H32311D406	Oil wick	1	1	
E70	H3407C0661	Needle bar vibrating crank(right)	1	1	
E71	H3407C0662	Connecting link	1	1	
E72	HE009D8001	Screw	1	1	
E73	HE508D8001	Vibrating presser foot	1	1	5/16
E73	HE305E8001	Vibrating presser foot	1	1	3/8

F. STITCH REGULATOR MECHANISM

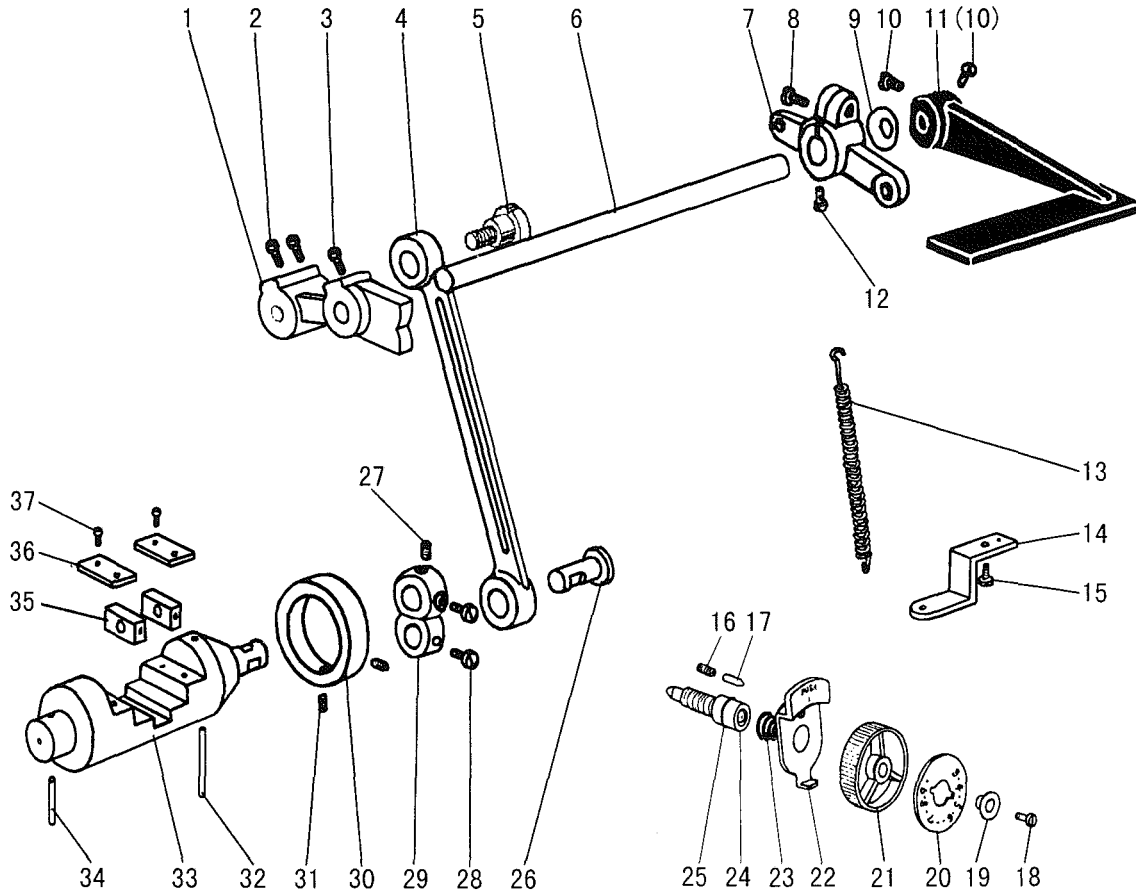

F.STITCH REGULATOR MECHANISM

Fig. No.	Part No.	Description	GC20638-25	GC20638-25D	Remarks
F01	H4706G8001	Feed regulator cam	1	1	
F02	HA113F0684	Screw	2	2	SM15/64 (28) ×8.5
F03	H3200F2020	Screw	1	1	SM15/64 (28) ×12
F04	H4707G8001	Link	1	1	
F05	HA100G2070	Eccentric shaft	1	1	
F06	H4709G8001	Reverse stitch shaft (upper)	1		
F06	H4909G8001	Reverse stitch shaft (upper)		1	
F07	H3207F0671	Arm	1		
F07	H4905G8001	Arm		1	
F08	HA800F2020	Screw	1	1	
F09	HA100F2110	Spring Washer	1		
F10	HA113F0684	Screw	2		
F11	H4711G8001	Reverse sewing lever	1		
F11	H4906G8001	Reverse sewing lever		1	
F12	H3207F0672	Screw	1	1	SM11/64 (40) ×8.5
F13	H4710G8001	Spring	1	1	
F14	H3200F2050	Guide plate	1		
F15	HA300C2030	Screw	1		SM11/64 (40) ×8
F16	H3200F2110	Spring	1	1	
F17	HA700F2030	Pin	1	1	
F18	HA720F0686	Screw	1	1	SM3/16(28)×18
F19	HA720F0685	Bushing	1	1	
F20	H4910G8001	Stitch length indicating plate	1	1	
F21	HA7421F120	Dial	1	1	
F22	HA720F0683	Stopper pin releasing lever	1	1	
F23	HA720F0687	Coil spring	1	1	
F24	HA109F0671	Screw bar	1	1	
F25	HA109F0674	O-ring	1	1	
F26	H3206F0662	Pin	1	1	
F27	H415050200	Screw	1	1	GB/T70.1 M5×20
F28	H428050060	Screw	2	2	GB/T77 M5×6
F29	H4714G8001	Reverse sewing crank	1	1	
F30	H4715G7101	Collar	1	1	
F31	HA3411D308	Screw	2	2	SM15/64(28)×7
F32	H4719G8001	Felt	1	1	
F33	H4720G8001	Rverse block	1	1	
F34	H4721G8001	Felt	1	1	
F35	H4722G8001	Square block	2	2	
F36	H4723G8001	Guide plate	2	2	
F37	HA300C2030	Screw	4	4	SM11/64 (40) ×8

G. LOWER SHAFT & FEED ROCK SHAFT MECHANISM

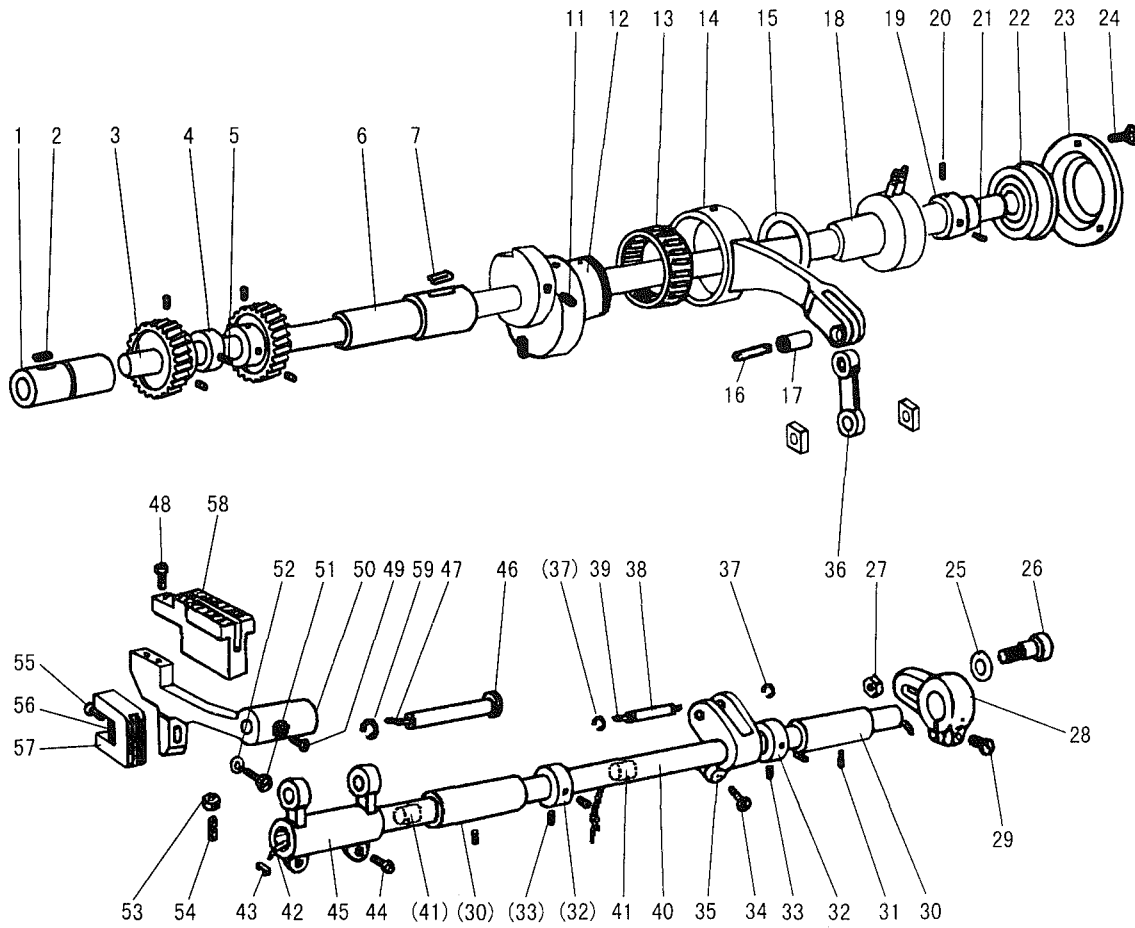

From the library of: Diamond Needle Corp

G.LOWER SHAFT & FEED ROCK SHAFT MECHANISM

Fig. No.	Part No.	Description	GC20638-25	GC20638-25D	Remarks
G01	H4706H8001	Lower shaft bushing (left)	1	1	
G02	H4707H8001	Oil wick	1	1	
G03	H7004H8001	Lower shaft	1	1	
G04	H4710H8001	Feed eccentric cam	1	1	
G05	H3205H0654	Screw	1	1	SM1/4(40)×5
G06	H4712H8001	Lower shaft bushing (right)	1	1	
G07	H4713H8001	Oil wick	1	1	
G11	H2405D0664	Screw	2	2	SM15/64(28)×14
G12	H4717H8001	Feed eccentric	1	1	
G13	H4719H8001	Needle bearing	1	1	
G14	H4718H8001	Feed connecting rod	1	1	
G15	H007009260	C-type stop ring	1	1	GB/T894.1 26
G16	H4720H8001	Oil wick	1	1	
G17	H4721H8001	Shaft	1	1	
G18	H7006H7101	Lower shaft bushing complete (middle)	1	1	
G19	H4725H8001	Bushing	1	1	
G20	HA105D0662	Screw	1	1	SM1/4 (40) ×4
G21	H3205H0654	Screw	1	1	SM1/4(40)×5
G22	H4723H8001	Ball bearing	1	1	
G23	H4727H8001	Bearing holder	1	1	
G24	HA7311C306	Screw	3	3	SM9/64 (40) ×7
G25	H4728H8001	Washer	1	1	
G26	H4729H8001	Screw	1	1	M6
G27	H003055060	Nut	1	1	GB52008 M6
G28	H4731H8001	Feed connection crank (right)	1	1	
G29	H2012N0652	Screw	1	1	SM1/4(24)×16
G30	HA100G2120	Feed rock shaft bushing	2	2	
G31	H4708D8001	Screw	2	2	SM1/4(24)×13
G32	HA108G0661	Collar	2	2	
G33	HA105D0662	Screw	4	4	1/4(40)×4
G34	H2012N0652	Screw	1	1	SM1/4(24)×16
G35	H4736H8001	Feed connection crank (middle)	1	1	
G36	H4737H8001	Link	1	1	
G37	H007013050	E-type stop ring	2	2	GB/T896 5
G38	H4738H8001	Pin	1	1	
G39	H4739H8001	Oil wick	1	1	
G40	H7005H8001	Feed rock shaft	1	1	
G41	H4740H8001	Felt	2	2	
G42	H3204G0031	Oil wick	1	1	
G43	H3200G2030	Clip	1	1	
G44	HA104G0012	Screw	2	2	SM3/16 (28) ×12
G45	H3205G1032	Feed connection crank (left)	1		
G45	H4905H8001	Feed connection crank (left)		1	

G.LOWER SHAFT & FEED ROCK SHAFT MECHANISM

Fig. No.	Part No.	Description	GC20638-25	GC20638-25D	Remarks
G46	H32243G205	Feed bar shaft	1	1	
G47	H3205G0662	Oil wick	1	1	
G48	H32211G205	Bolt	2	2	SM1/8(40)×7
G49	H429050050	Bolt	1	1	GB/T78 M5×5
G50	H32211GC05	Feed bar	1		
G50	H4942H8001	Feed bar		1	
G51	H3200H2040	Screw	1	1	SM15/64(28)×17
G52	H2013J0065	Washer	1	1	
G53	H003002030	Nut	1	1	GB/T6170 M3
G54	H429030140	Screw	1	1	GB/T78 M3×14
G55	H3205H0653	Screw	1	1	SM1/8 (44) ×4
G56	H3205H0652	Felt	1	1	
G57	H4743H8001	Feed bar forked connection	1	1	
G58	H4748H8001	Feed dog	1		5/16
G58	H4749H8001	Feed dog	1		3/8
G58	H4948H8001	Feed dog		1	5/16
G58	H4949H8001	Feed dog		1	3/8
G59	H007009070	C-type stop ring	1	1	

H. HOOK SADDLE MECHANISM

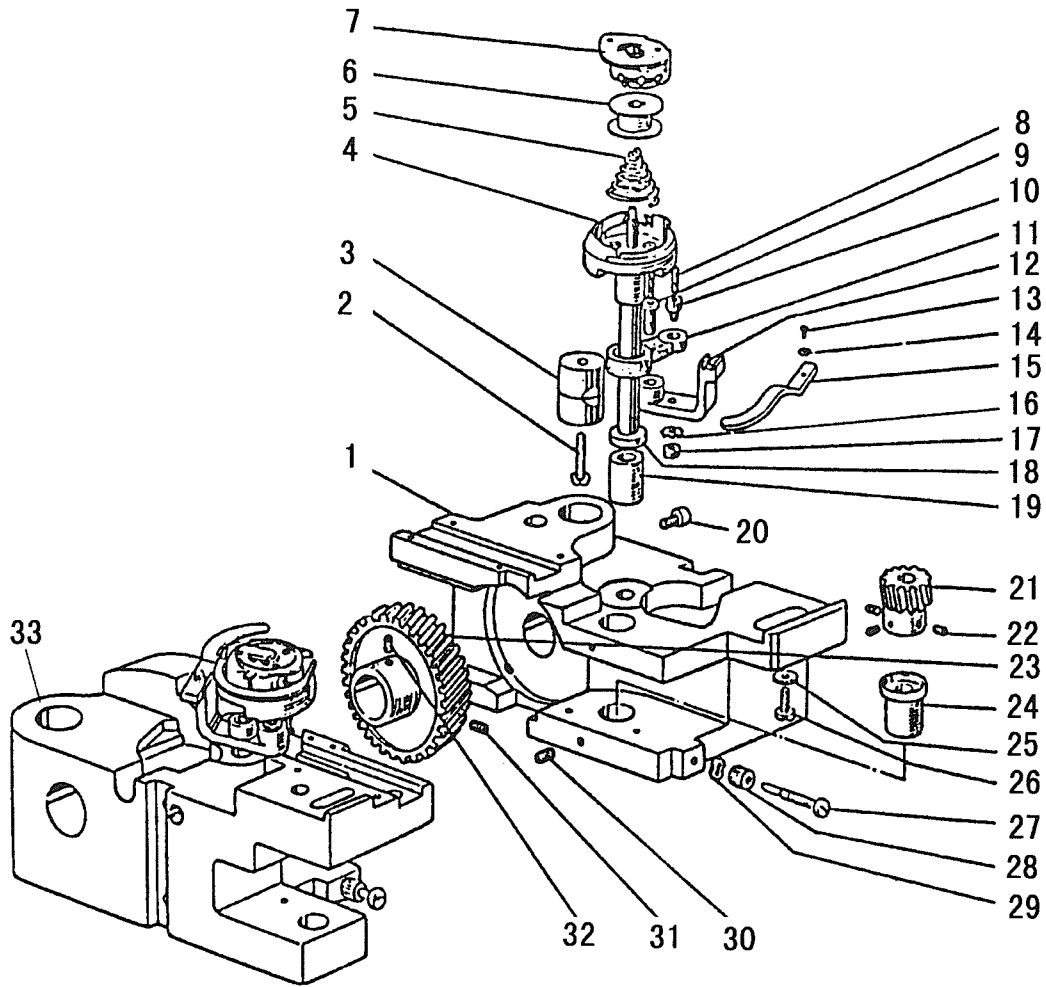

From the library of: Diamond Needle Corp

H.HOOK SADDLE MECHANISM

Fig. No.	Part No.	Description	GC20638-25	GC20638-25D	Remarks
H01	H3304I0651	Hook saddle (right)	1		
H01	H4906I8001	Hook saddle (right)		1	
H02	H3207I0661	Screw	2	2	SM15/64(28)×30
H03	H3207I0066	Bushing	2	2	
H04	H3500I2010	Hook complete	2		
H04	H9304J7101	Hook complete		2	HSH-12MC (3)
H05	H4922I8001	Spring		2	
H06	H3306I0067	Bobbin	2		
H06	H9305J8001	Bobbin		2	BO-112 (A) M
H07	H3505I0651	Bobbin case	2		
H07	H9306J8001	Bobbin case		2	CP-12MC (3)
H08	H3204I0656	Oil wick	2	2	2.5×15
H09	H32153I504	Bobbin case opener holder pin	2	2	
H10	H32153I204	Screw	2	2	SM3/16(32)×7.8
H11	H33131I204	Link	2	2	
H12	H33131I104	Bobbin case opener holder	2	2	
H13	H2004J0067	Screw	2	2	SM9/64 (40) ×7
H14	H3200I2030	Washer	2	2	
H15	H3305I0066	Opener	2	2	
H16	H005008050	Spring washer	2	2	GB/T93 5
H17	HA104G0658	Nut	2	2	SM3/16(32)
H18	H33121I204	Spacer	2	2	
H19	H33121I104	Hook shaft bushing (upper)	2	2	
H20	H3204I0657	Screw	2	2	SM3/16(28)×14.5
H21	H4705I8001	Gear (small)	2	2	
H22	HA105D0662	Screw	6	6	SM1/4 (40) ×4
H23	H4706I8001	Gear (large)	2	2	
H24	H3204I0653	Hook shaft bushing (lower)	2	2	
H25	H2013J0065	Washer	2	2	
H26	H3200I2050	Screw	2	2	SM1/4(24)×23
H27	H3204I0658	Screw	2	2	SM3/16(28)×43
H28	H3204I0659	Nut	2	2	SM3/16(28)
H29	H005014050	Spring washer	2	2	GB/T955 5
H30	HA305E0662	Screw	4	4	SM15/64 (28) ×4.5
H31	HA307C0662	Screw	2	2	SM1/4 (40) ×6
H32	H4707I8001	Screw	2	2	SM1/4(40)×6.5
H33	H3307I0681	Hook saddle (left)	1		
H33	H4917I8001	Hook saddle (left)		1	

I. THREAD TRIMMER MECHANISM

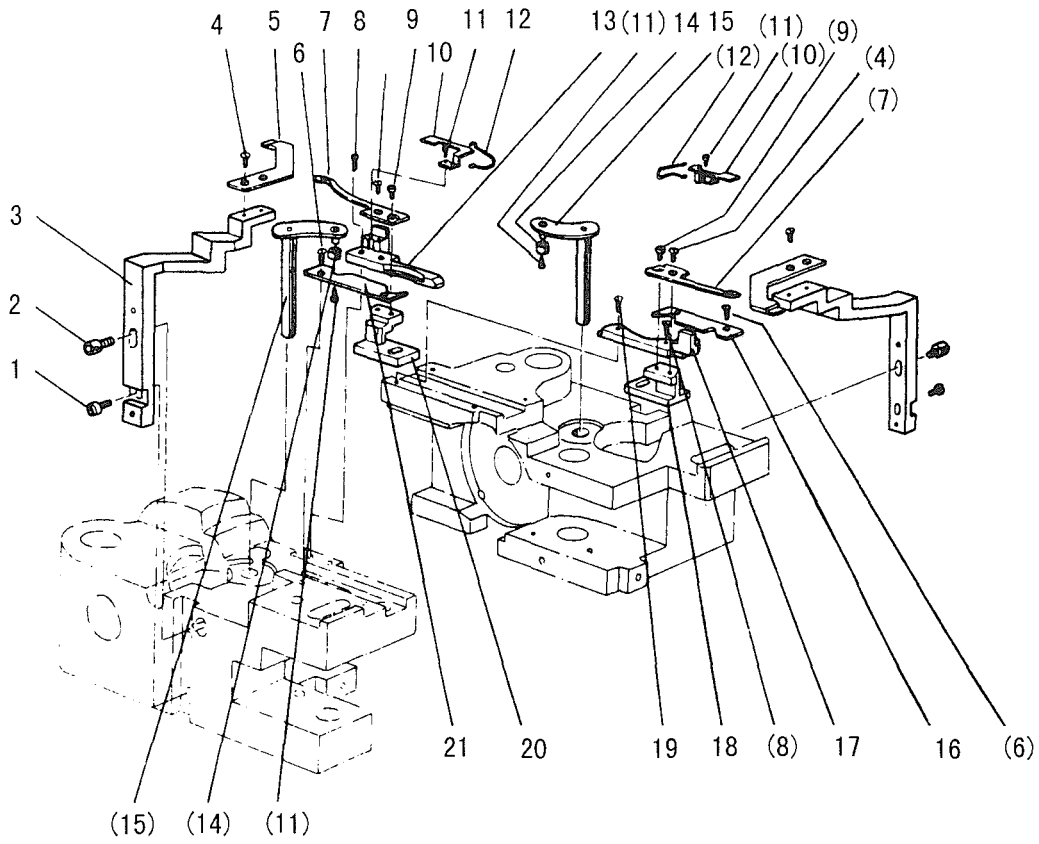

From the library of: Diamond Needle Corp

I.THREAD TRIMMER MECHANISM

Fig. No.	Part No.	Description	GC20638-25	GC20638-25D	Remarks
I01	H4905J8001	Screw		2	
I02	H4906J8001	Bolt		2	SM11/64 (40) ×12
I03	H4907J8001	Trimming knife holder		2	
I04	H4908J8001	Screw		6	SM9/64 (40) ×4
I05	H4909J8001	Fixed blade		2	
I06	H4914B8001	Screw		4	SM9/64 (40) ×4
I07	H4911J8001	Moved knife		2	
I08	H4912J8001	Screw		2	SM1/8 (44) ×9.2
I09	H4913J8001	Screw		2	SM9/64 (40) ×4.5
I10	H4914J8001	Spring plate		2	
I11	H4915J8001	Screw		6	SM3/32 (56) ×3.8
I12	H4916J8001	Reversing spring		2	
I13	H4917J8001	Guide		1	
I14	H4920J8001	Roller		2	
I15	H4921J8001	Lever		2	
I16	H4922J8001	Cover		1	
I17	H4923J8001	Guide (right)		1	
I18	H4924J8001	Knife pad (right)		1	
I19	H4925J8001	Screw		1	SM9/64 (40) ×9.5
I20	H4926J8001	Knife pad (left)		1	
I21	H4927J8001	Cover		1	

J. THREAD TRIMMER MECHANISM

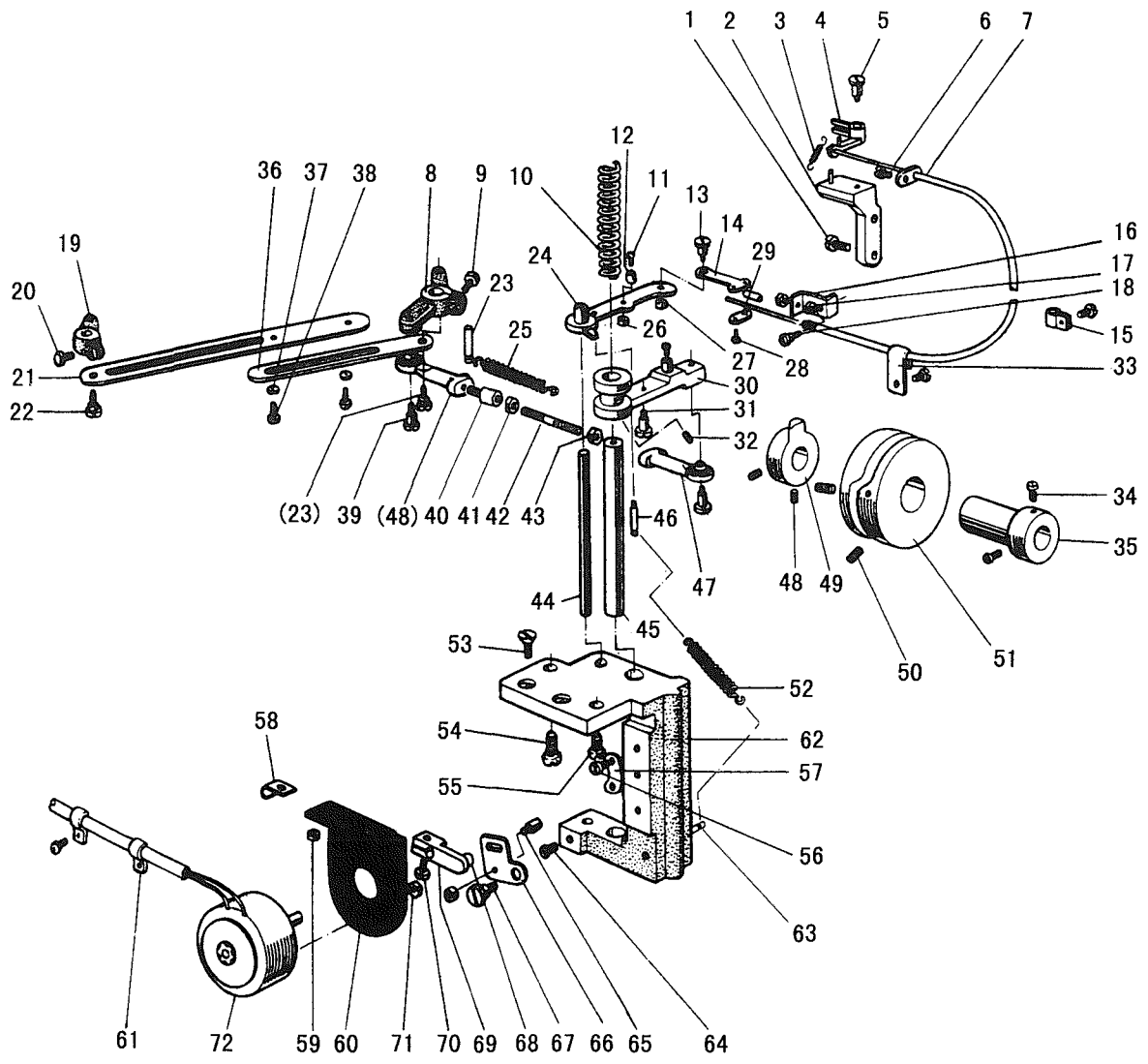

From the library of: Diamond Needle Corp

J.THREAD TRIMMER MECHANISM

Fig. No.	Part No.	Description	GC20638-25	GC20638-25D	Remarks
J01	HA300C2030	Screw		2	SM11/64 (40) ×8
J02	H4915K7101	Thread releading bracket		1	
J03	H4918K8001	Spring		1	
J04	H4919K7101	Thread releading plate		1	
J05	H2400I2040	Screw		1	SM11/64 (40) ×5
J06	HA300B2170	Screw		4	SM11/64 (40) ×8
J07	H0604K7101	Flexible wire complete		1	
J08	H4912K8001	Arm		1	
J09	H4913K8001	Bolt		1	SM15/64 (28) ×12.5
J10	H4945K8001	Spring		1	
J11	H4950K8001	Screw		1	SM11/64 (40) ×3.6
J12	H4949K8001	Roller		1	
J13	H4952K8001	Screw		1	SM3/16 (28) ×5
J14	H4953K8001	Mounting plate		1	
J15	HA700Q0030	Nylon clip		1	
J16	H4925K8001	Mounting plate		1	
J17	H003002050	Nut		2	GB/T6170 M5
J18	HA300C2030	Screw		1	SM11/64 (40) ×7
J19	H4908K8001	Arm		1	
J20	H4907K8001	Bolt		1	SM15/64 (28) ×12.5
J21	H4906K8001	Link		1	
J22	H4905K8001	Screw		2	M5(0.5)×7.5
J23	HA100H2080	Pin type		1	
J24	H4946K7101	Thread releasing lever		1	
J25	H4943K8001	Spring		1	
J26	H4951K8001	Nut		1	SM11/64 (40)
J27	H4954K8001	Nut		1	SM3/16 (28)
J28	H4956K8001	Screw		2	SM1/8 (44) ×7
J29	H4955K8001	Bushing		1	
J30	H4957K7101	Vibrating crank		1	
J31	H4944K8001	Screw		1	SM11/64 (40) ×5.5
J32	H3205G1114	Screw		2	M5×5
J33	HA708P0668	Nylon clip		1	
J34	HA113F0684	Screw		2	SM15/64 (28) ×8.5
J35	H4931K8001	Bushing		1	
J36	H4909K8001	Link		1	
J37	H005001050	Washer		1	GB/T97.1 5
J38	H4911K8001	Bolt		2	
J39	H4936K8001	Screw		2	M5(0.5)×8.5
J40	H4987K8001	Bolt		1	
J41	H4940K8001	Nut (left)		1	M5(left)
J42	H4939K8001	Bolt		1	
J43	H003002050	Nut (right)		1	GB/T6170 M5

J.THREAD TRIMMER MECHANISM

Fig. No.	Part No.	Description	GC20638-25	GC20638-25D	Remarks
J44	H4964K8001	Shaft		1	
J45	H4963K8001	Shaft		1	
J46	H4985K8001	Screw		1	SM11/64 (40) ×4
J47	H3405D0663	Ball joint (right)		2	
J48	H3205G1114	Screw		4	M4×4
J49	H4934K8001	Cam		1	
J50	HA710E0692	Screw		2	SM1/4 (40) ×9.5
J51	H4932K8001	Cam		1	
J52	H4986K8001	Spring		1	
J53	H411050160	Screw		2	GB/T819.1 M5×16
J54	H2012N0652	Screw		1	SM1/4 (24) ×16
J55	H4983K8001	Screw		1	SM1/4 (24) ×13
J56	H4967K8001	Screw		3	SM11/64 (40) ×7
J57	H4966K8001	Stopper		1	
J58	H4981K8001	Holder		1	
J59	H003008050	Nut		2	GB/T6172.1 M5
J60	H4977K8001	Mounting plate		1	
J61	H4980K8001	Holder		2	
J62	H4965K8001	Set plate		1	
J63	H3700E2080	Pin type		1	
J64	H4969K8001	Screw		1	SM11/64 (40) ×8.5
J65	H4970K8001	Screw		1	SM11/64 (40) ×6
J66	H4971K8001	Lever		1	
J67	H4972K8001	Screw		1	SM11/64 (40) ×6.8
J68	H4973K8001	Pin		1	
J69	H4974K8001	Arm		1	
J70	HA111G0683	Screw		1	SM11/64 (40) ×12
J71	HA7111N304	Nut		1	SM11/64 (40)
J72	H4979K8001	Solenoid complete		1	

K. TOUCH BACK AND DETECTOR MECHANISM

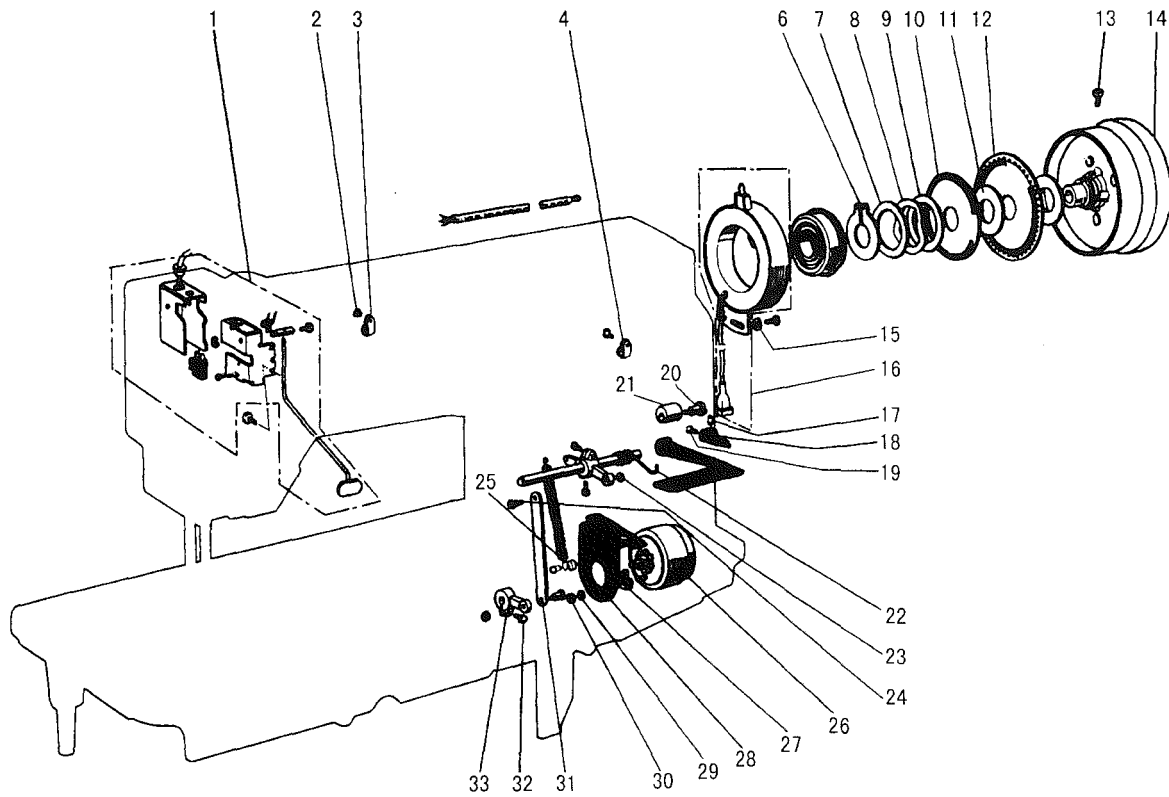

From the library of: Diamond Needle Corp

K.TOUCH BACK AND DETECTOR MECHANISM

Fig. No.	Part No.	Description	GC20638-25	GC20638-25D	Remarks
K01	HE10K57101	Touth switch complete		1	
K02	H4918L8001	Screw		4	M5
K03	HA700Q0030	Holder		2	
K04	H4922L8001	Holder		1	
K06	H007009300	Retaining ring C-type		1	GB/T894.1 30
K07	HA700R0060	Washer		1	
K08	HA700R0050	Support spring		1	
K09	HA700R0040	Spacer B		1	
K10	H4928L8001	Speed command disk F20 (up)		1	
K11	HA700R0030	Spacer A		2	
K12	H4930L8001	Speed command disk F11 (down)		1	
K13	HA110D0672	Screw		2	SM15/64 (28) ×12
K14	H4931L8001	Pulley (complete)		1	
K15	HA703R0067	Washer		1	
K16	HA703R0065	Detector bracket (complete)		1	
K17	HA3411D308	Screw		1	SM15/64 (28) ×7
K18	H4936L8001	Lever		1	
K19	HA113F0684	Screw		1	SM15/64 (28) ×7.5
K20	H4937L8001	Screw		1	SM15/64 (28) ×6
K21	H4938L8001	Rubber ring		1	
K22	H4939L8001	Spring		1	
K23	H4940L8001	Nut		2	
K24	H4941L8001	Screw		2	SM15/64 (28) ×14
K25	H4942L8001	Nut		1	
K26	H4943L8001	Solenoid (complete)		1	
K27	H102080120	Blot		2	GB/T5781 M8×12
K28	H4945L8001	Set plate		1	
K29	H005008060	Spring washer		2	GB/T93 6
K30	H003002060	Nut		2	GB/T6170 M6
K31	H4948L8001	Link		1	
K32	H4949L8001	Blot		1	SM15/64 (28) ×13
K33	H4950L8001	Arm		1	
K34	HA300C2030	Screw		2	SM11/64 (40) ×8

L. OIL LUBRICATION MECHANISM

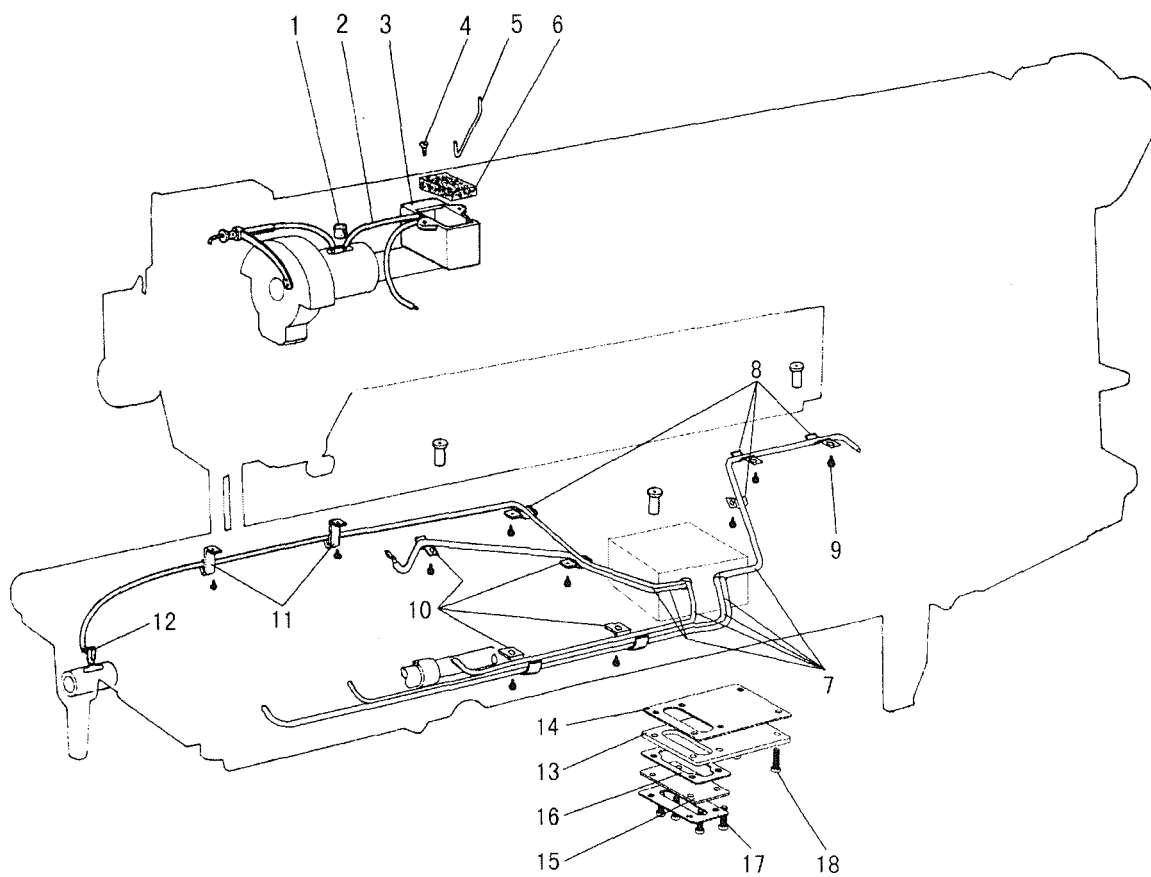

From the library of: Diamond Needle Corp

L.OIL LUBRICATION MECHANISM

Fig. No.	Part No.	Description	GC20638-25	GC20638-25D	Remarks
L01	H32175B304	Felt	1	1	
L02	H4705J7101	Oil pipe complete	1	1	
L03	H3204K0011	Oil reservoir complete	1	1	
L04	H411040160	Screw	2	2	GB/T819.1 M4×16
L05	H4707J8001	Holder	1	1	
L06	H7005J8001	Felt	1	1	
L07	H7007J7101	Oil pipe complete	6	6	
L08	H32311D606	Holder	4	4	
L09	HA106B0676	Screw	10	10	SM9/64 (40) ×4.5
L10	H3200K0170	Holder	4	4	
L11	H3200K0160	Holder	2	2	
L12	H3200K0180	Oil wick $\Phi 2.5 \times 35$	3	3	
L13	H7020J8001	Pressing plate	1	1	
L14	H7021J8001	Sealed cushion	1	1	
L15	H2000M0180	The oil amount observes window	1	1	
L16	H2000M0190	Sealed cushion	1	1	
L17	H2000M0200	Sealed cushion	1	1	
L18	H3107G0661	Screw	6	6	

M. ACCESSORIES

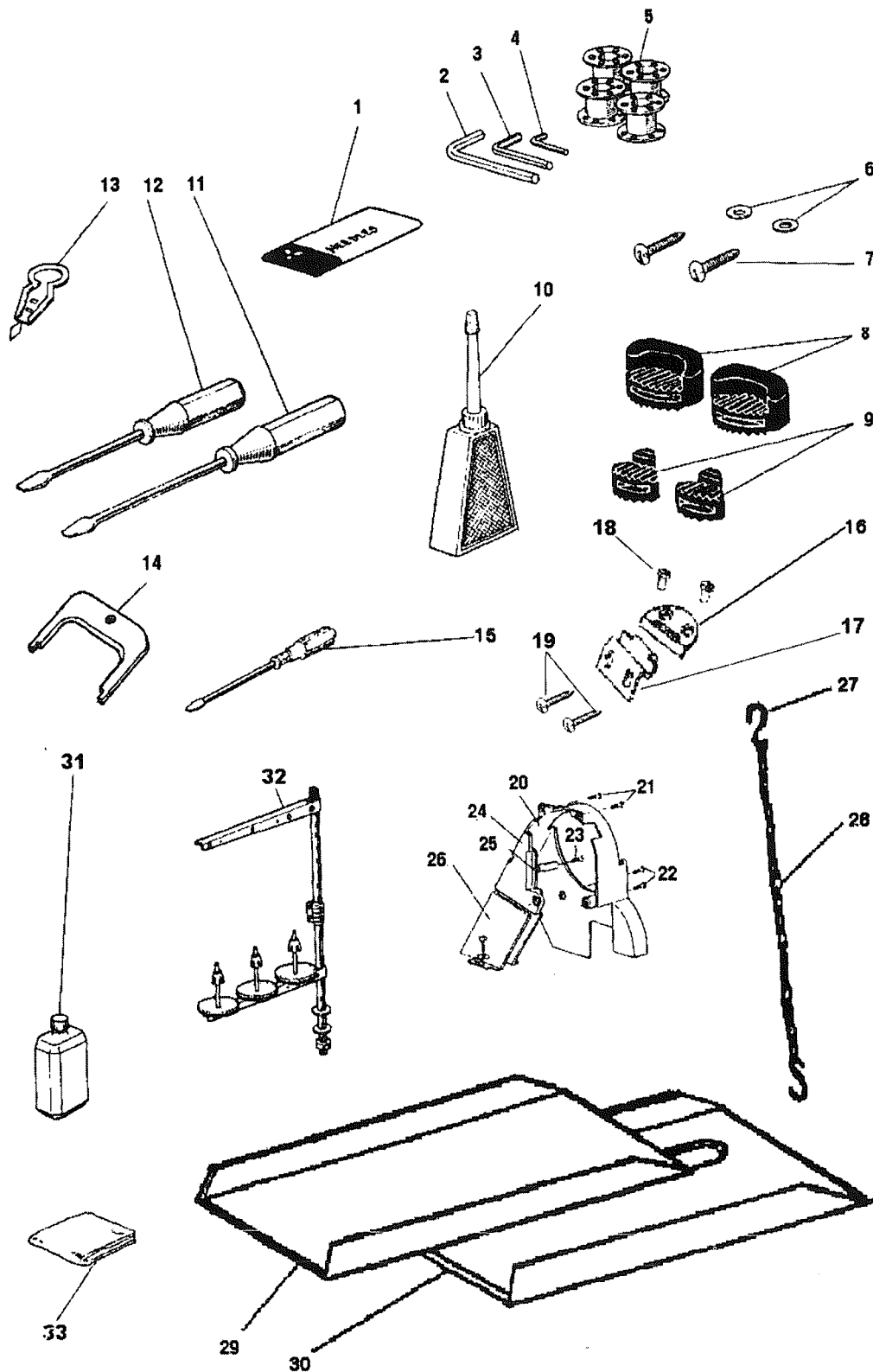

M.ACCESSORIES

Fig. No.	Part No.	Description	GC20638-25	GC20638-25D	Remarks
M01	H4740F8001	Needle DP×17-23	6	6	
M02	H3209L8001	Socket wrench	1	1	
M03	H3208L8001	Socket wrench	1	1	
M04	H4905N8001	Socket wrench	1	1	
M05	H4912I8001	Bobbin	4	4	B0-B872 (A)
M06	H3200L0050	Washer	2	2	
M07	H801045200	Screw	4	4	GB/T99 4.5×20
M08	H4700K0020	Vibration preventing rubber	2	2	
M09	H4700K0030	Vibration preventing rubber	2	2	
M10	HA100J2110	Oiler	1	1	
M11	HA100J2140	Screw driver (middle)	1	1	
M12	HA100J2150	Screw driver (small)	1	1	
M13	H3207L0065	Thread a needle kit	1	1	
M14	HA704S0654	Adjusting plate for speed command disk	1	1	
M15	HA300J2070	Screw driver (large)	1	1	
M16	H2404K0654	Hinge complete	2	2	
M17	H2404K0655	Hinge complete	2	2	
M18	H2404K0656	Screw	4	4	
M19	H802080350	Screw	4	4	GB/T100 8×35
M20	H2008O0068	Belt cover	1	1	
M21	HA300C2170	Screw	2	2	SM11/64 (40) ×8
M22	HA300J2280	Screw	2	2	SM11/64 (28) ×8
M23	HA300J2250	Screw	1	1	M4×8
M24	H4708K7101	Belt cover complete	1	1	
M25	H003008040	Nut	1	1	GB/T6172.1 M4
M26	HA305J0665	Belt cover	1	1	
M27	HPG100E202	Pothead	2	2	
M28	HPG100E203	Chain	1	1	
M29	H7013K8001	Oil check	1	1	
M30	H7014K8001	Oil check	1	1	
M31	H3200L0130	Oil box	1	1	
M32	H3200L0120	Knee lift shaft	1	1	
M33	H7009K8001	Vinyl cover	1	1	

SHANGHAI HUIGONG NO.3 SEWING MACHINE FACTORY

ADD: 1418, Yishan Road, Shanghai, China

Zip Code: 201103

Overseas Business: TEL: 86-21-64853303 FAX: 86-21-64854304

E-mail: highlead@online.sh.cn <http://www.highlead.com.cn>

The description covered in this manual is subject to change for improvement of the commodity without notice

2008.5. Printed