



海菱
® **HIGHLEAD**

GC188-M-D

高速平缝机

使用说明书

零件样本

上海惠工缝纫机三厂
SHANGHAI HUIGONG NO.3 SEWING MACHINE FACTORY

安全、安装操作说明 SAFETY OPERATION INSTRUCTION

为了您安全进行工作，在安装、调试机器前，或进行更换零部件、维修等工作之前，请认真阅读使用说明书。若不按照使用说明书操作，可能造成人身事故。

为了您充分理解机器上粘贴的警示标识，特做如下说明。

In order to operate machine safety, please read the INSTRUCTION MANUAL carefully before installing, operating machine or exchanging parts and making maintenance. If not, it will cause personal injuries.

To make you kown well, explain the machine's warning marks as follows:

一、警告标识表示及指示标识 WARNING FIGURES AND MARKS

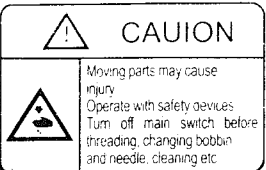
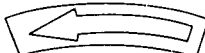
警告标识 Warning Figure	表示内容 Meaning	指示标识 Warning Mark	标识内容 Meaning
	运动部位，谨防工作事故 Motion section, Be cautious of injuries		指示正确旋转方向 Showing right rotation direction

二、安全装置警告标识 WARNING MARK OF SAFETY DEVICE

1. 为了防止因安全装置的缺欠而造成的事故，在实际操作前，请确认安全装置（如皮带罩、护指安全框、护眼安全板，详见附图一、二）是否正确安装在其相应位置上，然后才能进行操作。
2. 为了防止人身事故，在安全装置被拆下的场合，请将其恢复原位，并确认其可以起到安全防护的作用，方可操作机器。
3. 为了防止人身事故，机器上所粘贴的警示标识，要经常保持清晰可见。

1. In order to avoid the accident occuring which caused by the deficits of safety device, before operation, make sure the safety device at itis right position, for example the belt, the finger guard and the safety plate.
2. Before operation, make sure the removed safety device has been installed well and ascertain itis effects.
3. Keep the warning marks clean and clear.

重要安全事项

此缝纫机在有的国家(设置场所)由于该国的安全规定而被禁止使用。同时, 技术服务也同样被禁止。

1. 使用此缝纫机时, 必须遵守包括如下项目的基本安全措施。
2. 使用此缝纫机之前, 请阅读本使用说明书在内的所有指示文件, 同时应将此使用说明书妥善保管, 以便能够随时查阅。
3. 此缝纫机应与贵国的有关安全规定一起使用。
4. 使用此缝纫机和缝纫机动作中, 所有的安全装置应安装到规定的位置。没有安装规定的安全装置的缝纫机禁止使用。
5. 此缝纫机应由接受过培训的操作人员来操作。
6. 使用缝纫机时, 建议戴安全防护眼镜。
7. 发生下列情况时, 应及时关掉电源开关, 或拔下电源线插头。
 - 7-1机针、弯针、分离器等穿线和更换旋梭时。
 - 7-2更换机针、压脚、针板、弯针、分离器、送布牙、护针器、支架、布导向器等时。
 - 7-3修理时。
 - 7-4工作场所无人了或离开工作场所时。
 - 7-5使用离合马达时, 请等待马达完全停止之后再行。
8. 缝纫机以及附属装置使用的机油、润滑脂等液体流入眼睛或沾到皮肤上时, 或被误饮时, 应立即清洗有关部份并去医院治疗。

9. 禁止用手触摸打开了缝纫机开关通电的零件或装置。
10. 有关缝纫机的修理、改造、调整应由受过专门训练的技术人员或专家来进行。
11. 一般的维修保养应由受过训练的人员来进行。
12. 有关缝纫机的电气方面的修理、维修应由有资格的电气技术人员或专家的监督和指导下进行。
13. 修理、保养有关空气、气缸等压缩空气的零件时, 应切断空气压缩机供气源后再进行。

如有残留压缩空气时, 应放掉压缩空气。
但, 受过相当训练的技术人员或专家进行有关调整或确认动作时除外。
14. 缝纫机的使用期间应定期进行清扫。

15. 为了正常安全运转, 应安装地线。同时应在不受高频焊接机等强噪音源影响的环境下使用。
16. 电源插头应用具有电气专门知识的人来安装。电源插头必须连接到接地插座上。

17. 缝纫机指定用途以外不能使用。
18. 对缝纫机的改造、变更应符合安全规格, 并采取有效的安全措施。另外, 对于有关改造和变更, 发利市公司概不负责。

19. 本使用说明书上采用以下2个警告符号。





有损伤操作人员、维修人员的危险。



安全上需要特别加以注意的事项。

为了安全地使用缝纫机的注意事项

 <p>危险</p>	<ol style="list-style-type: none">1. 为了防止发生触电事故，请不要在打开电源的状态下，打开电气箱盖及触摸电气箱内的零件。
 <p>注意</p>	<ol style="list-style-type: none">1. 为了防止人身事故的发生，请不要在卸下皮带防护罩、手指防护器等安全装置的状态下运转缝纫机。2. 为了防止被卷入机器的人身事故，缝纫机运转中请不要将手指、头发、衣服靠近皮带轮、V形皮带、马达，也不要东西放到机器上面。3. 为了防止人身事故的发生，打开电源时以及缝纫机运转中，请不要把手指放到机针的附近。4. 为了防止人身事故的发生，缝纫机运转中请不要把手指放到挑线杆外罩内。5. 缝纫机操作中，旋梭高速地旋转。为了防止手受到伤害，运转中请绝对不要把手靠近旋梭。6. 为了防止人身事故的发生，放倒缝纫机或返回原来位置时，要注意不要夹住手。7. 为了防止突然的起动造成人身事故，放倒缝纫机时，或卸皮带罩和V形皮带时，请一定关掉电源。8. 使用伺服马达时，缝纫机停止马达无声音。为了防止意外的起动造成人身事故，请注意不要忘记关电源。9. 为了防止触电事故，卸下电源地线的状态，请不要运转缝纫机。10. 为了防止触电和损坏电气零件，拔电源的插头时，请先关掉机器电源开关。

IMPORTANT SAFETY INSTRUCTIONS

Putting sewing systems into operation is prohibited until it has been ascertained that the sewing systems in which these sewing machines will be built into, have conformed with the safety regulations in your country. Technical service for those sewing systems is also prohibited.

1. Observe the basic safety measures, including, but not limited to the following ones, whenever you use the machine.
2. Read all the instructions, including, but not limited to this Instruction Manual before you use the machine. In addition, keep this Instruction Manual so that you may read it at anytime when necessary.
3. Use the machine after it has been ascertained that it conforms with safety rules/standards valid in your country.
4. All safety devices must be in position when the machine is ready for work or in operation. The operation without the specified safety devices is not allowed.
5. This machine shall be operated by appropriately-trained operators.
6. For your personal protection, we recommend that you wear safety glasses.
7. For the following, turn off the power switch or disconnect the power plug of the machine from the receptacle.
 - 7-1 For threading needle(s), looper, spreader etc. and replacing bobbin.
 - 7-2 For replacing part(s) of needle, presser foot, throat plate, looper, spreader, feed dog, needle guard, folder cloth guide etc
 - 7-3 For repair work.
 - 7-4 When leaving the working place or when the working place is unattended.
 - 7-5 When using clutch motors without applying brake, it has to be waited until the motor stopped totally.
8. If you should allow oil, grease, etc. use with the machine and devices to come in contact with your eyes or skin or swallow any of such liquid by mistake, immediately wash the contacted areas and consult a medical doctor.

9. Tampering with the live parts and devices, regardless of whether the machine is powered, is prohibited.
10. Repair, remodeling and adjustment works must only be done by appropriately trained technicians or specially skilled personnel. Only spare parts designated by JUKI can be used for repairs.
11. General maintenance and inspection works have to be done by appropriately trained personnel.
12. Repair and maintenance works of electrical components shall be conducted by qualified electric technicians or under the audit and guidance of specially skilled personnel.
Whenever you find a failure of any of electrical components, immediately stop the machine.
13. Before making repair and maintenance works on the machine equipped with pneumatic parts such as an air cylinder, the air compressor has to be detached from the machine and the compressed air supply has to be cut off.
Existing residual air pressure after disconnecting the air compressor from the machine has to be expelled.
Exceptions to this are only adjustments and performance checks done by appropriately trained technicians or specially skilled personnel.
14. Periodically clean the machine throughout the period of use.

15. Grounding the machine is always necessary for the normal operation of the machine. The machine has to be operated in an environment that is free from strong noise sources such as high-frequency welder
16. An appropriate power plug has to be attached to the machine by electric technicians. Power plug has to be connected to a grounded receptacle.

17. The machine is only allowed to be used for the purpose intended. Other used are not allowed.
18. Remodel or modify the machine in accordance with the safety rules/standards while taking all the effective safety measures. Falishi Co., Ltd. assumes to responsibility for damage caused by remodeling or modification of the machine

19. Warning hints are marked with the two shown symbols



Danger of injury to operator or service staff



Items requiring special attention

FOR SAFE OPERATION



- 1 To avoid electrical shock hazards, neither open the cover of the electrical box for the motor nor touch the components mounted inside the electrical box.



1. To avoid personal injury, never operate the machine with any of the belt cover, finger guard or safety devices removed.
2. To prevent possible personal injuries caused by being caught in the machine, keep your fingers, head and clothes away from the handwheel, V belt and the motor while the machine is operation. In addition, place nothing around them.
3. To avoid personal injury, never put your hand under the needle when you turn "ON" the power switch or operate the machine.
4. To avoid personal injury, never put your fingers into the thread take-up cover while the machine is in operation.
5. The hook rotates at a high speed while the machine is in operation, To prevent possible injury to hands, be sure to keep your hands away from the vicinity of the hook during operation. In addition, be sure to turn OFF the power to the machine when replacing the bobbin.
6. To avoid possible personal injuries, be careful not to allow your fingers in the machine when tilting/raising the machine head
7. To avoid possible accidents because of abrupt start of the machine, turn OFF the power to the machine when tilting the machine head or removing the belt cover and the V belt.
8. If your machine is equipped with a servo-motor, the motor does not produce noise while the machine is at rest. To avoid possible accidents due to abrupt start of the machine, be sure to turn OFF the power to the machine.
9. To avoid electrical shock hazards, never operate the sewing machine with the ground wire for the power supply removed.
10. To prevent possible accidents because of electric shock or damaged electrical components(s), turn OFF the power switch in prior to the connection/disconnection of the power plug.

目 录

Contents

使用说明	
Operation Manual	1
零件样本	
Parts Book	25
GC188-M-D型(中厚料用)	
Model GC188-M-D (For Medium Heavy Materials)	26
1、机壳分组件	
Arm Bed components	26
2、上轴、挑线分组件	
Main Shaft & Thread Take-up Components	28
3、针杆、夹线分组件	
Needle Bar & Thread Tension Components	30
4、压料、松线分组件	
Presser & Tension Release Bar Components	32
5、勾线分组件	
Hook Priving Shaft Components	34
6、送料分组件	
Feed Mechanism Components	36
7、送料调节分组件	
Feed Regulating Components	38
8、剪线分组件	
Thread Trimmer Components	40
9、拨线分组件	
Wiper Components	42
10、润滑分组件	
Lubrication Components	44
11、油盘、膝抬压脚分组件	
Oil Reservoir & Knee Lifter Components	46
12、机头附件(1)	
Machine Head Accessories(1)	48
机头附件(2)	
Machine Head Accessories(2)	50
13、机架、台板、电器分组件	
Machine Stand, Table & Electric Appliance Components	52

开车前的注意事项:
BEFORE OPERATION



注意

为了防止机械的错误协作或损伤，请确认如下项目。



CAUTION:

To avoid malfunction and damage of the machine, confirm the following

1. 油盘内未加油绝不能开车。
 2. 机器运转时，从上轮外侧看转向应为逆时针方向。注意，不能倒转。
 3. 在第一月中，不要选用大尺寸的电动机皮带轮。
 4. 确认电动机标牌上所标电压及相位是否正确。
1. Never operate the machine unless its oil pan has been filled with oil.
 2. After setting up the machine, check the direction of motor rotation. To check it, turn the handwheel by hand to bring the needle down, and turn the power switch ON while observing the handwheel. (The handwheel should turn counterclockwise as observed from the handwheel side.)
 3. Do not use a larger motor pulley for the first one month.
 4. Confirm that the voltage and phase (single or 3-phase) are correct by checking them against the ratings shown on the motor nameplate.

使用注意事项:
OPERATION PRECAUTIONS



注意

为了防止意外的起动造成的事故，请关掉电源后再进行。



WARNING:

Turn OFF the power before starting the work so as to prevent accidents caused by abrupt start of the sewing machine.

1. 接通电源开关或机器运转时，请勿将手放到针的下部。
 2. 机器运转时，请勿将手指伸入挑线杆护罩内。
 3. 机头翻动及拆三角皮带时，一定要切断电机开关。
 4. 操作者离开机器时，必须切断电源。
 5. 机器运转期间，注意不允许任何人的头或手以及任何东西靠近上轮“V”形皮带，绕线轮和电动机。
 6. 装拆皮带罩、防护罩、或者其它保护装置时，请勿开动机器。
 7. 不要用香蕉水等油漆稀释剂擦洗机头表面。
 8. 定期清除机器的灰尘、布屑、线头，做好保养工作。
1. Keep your hands away from the needle when you turn the power switch ON or while the machine is operating.
 2. Do not put your fingers into the thread take-up cover while the machine is operating.
 3. Be sure to turn the power switch OFF before tilting the machine head or removing the V belt.
 4. When an operator leaves from the machine, make sure to turn off the power.
 5. During operation, be careful not to allow your or any other person's head or hands to come close to the handwheel, V belt, bobbin winder or motor. Also, do not place anything close to them. Doing so may be dangerous.
 6. If your machine is provided with a belt cover, finger guard or any other protectors, do not operate your machine with any of them removed.
 7. Don't clean the face of machine head with thinner.
 8. Periodically clear dust and lint from the machine, and do the maintenance work.

1. 机器的安装(图1、图2、图3、图4)

1. INSTALLATION (Fig.1, Fig.2, Fig.3, Fig.4)

* 油盘安装:

- 1) 油盘应搁在工作台凹槽的四角。
- 2) 如图所示, 将两只油盘支座①用油盘座钉②固定在A一边(朝操作者一边), 将两只油盘座垫③用油盘座钉②固定在B一边(用机头连接钩接合一边), 最后把油盘④放在其上。(图1、图2)
- 3) 将机头连接钩①放入底板孔内, 与台板的机头连接钩座②相嵌合, 再将机头放到四只角的机头座垫③上。(图3、图4)

* Installing the oil pan

- 1) The oil pan should rest on the four corners of the machine table groove.
- 2) Fix two rubber seats ① on side A (operator's side) using nails ② as illustrated above. Fix two cushion seats ③ on side B (hinged side) using nails ②. Then place oil pan ④ on the fixed seats. (Fig.1, Fig.2)
- 3) Fit hinge ① into the opening in the machine bed, and fit the machine head to table rubber hinge ② before placing the machine head on cushions ③ on the four corners. (Fig.3, Fig.4)

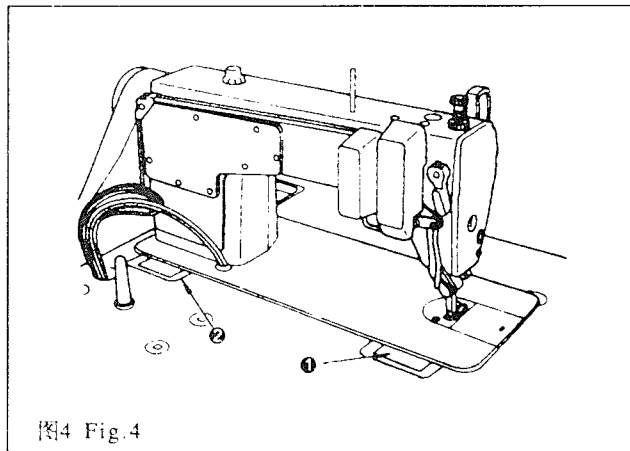
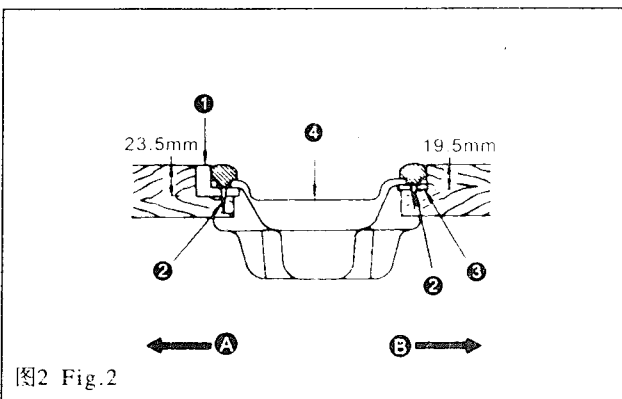
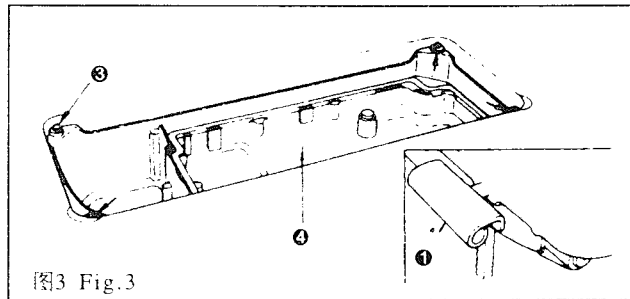
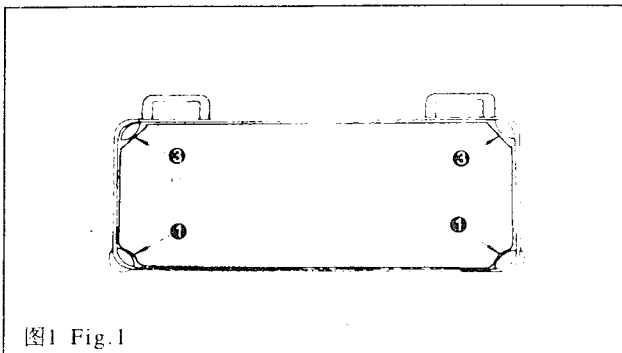

1. 机器的润滑(图5、图6)

1. LUBRICATION (Fig.5, Fig.6)

1. 润滑须知: (图5)

* 开车前:

- 1) 向油盘①内加缝纫机油(10号白油)至HIGH记号部位A。(图5)
- 2) 当油面低于LOW记号B, 应再加油。
- 3) 加油后, 开动机器, 应看到油液飞溅到油窗②上, 说明润滑正常。
- 4) 至于飞溅的油量多少与总润滑油量多少无关。

* 注意:

使用新机器或者长期未使用过的机器时, 应在每分钟3000~3500针的状态下使机器进行十分钟左右的适应性运转。

2. 调节面部油量: (图6)

- 1) 转动油量调节销①, 可以调节挑线曲柄②的供油量。
- 2) 油量调节销朝B方向转动, 刻点A靠近挑线曲柄时, 油量达到最小值。
- 3) 油量调节销朝C方向转动, 刻点A背离挑线曲柄时, 油量达到最大值。

3. 调节旋梭油量: (图6)

- 1) 将下轴前轴套上的油量调节螺钉③朝+方向A转动时, 油量将增大。
- 2) 当油量调节螺钉③朝-方向B转动时, 油量将减小。

1. Information on lubrication (Fig.5)

* Before starting the machine

- 1) Fill oil pan ① with sewing machine oil (10 white oil) up to HIGH mark A.
- 2) When the oil level lowers below LOW mark B, refill the oil pan with the specified oil.
- 3) When you operate the machine after lubrication, you will see splashing oil through oil sight window ② if the lubrication is adequate.
- 4) Note that the amount of the splashing oil is unrelated to the amount of the lubricating oil.

* Precaution

When you first operate your machine after set up or after an extended period of disuse, run your machine at 3,000 s.p.m. To 3,5000 s.p.m for about 10 minutes for the purpose of break-in.

2. Adjusting the amount of oil supplied to the face plate parts (Fig.6)

- 1) Adjust the amount of oil supplied to the thread take-up and needle bar crank ② by turning adjust pin ①.
- 2) The minimum amount of oil is reached when marker dot A is brought close to needle bar crank ② by turning the adjust pin in direction B.
- 3) The maximum amount of oil is reached when marker dot A is brought to the position just opposite from the needle bar crank by turning the adjust pin in direction C.

3. Adjusting the amount of oil supplied to the the hook (Fig.6)

- 1) More oil is supplied as oil amount adjust screw ③ mounted on the hook driving shaft is turned toward + (in direction A).
- 2) As the oil amount adjust screw ③ is turned toward - (in direction B), the amount of oil supplied will be decreased.



图5 Fig.5



图6 Fig.6

3. 机针的装法(图7)

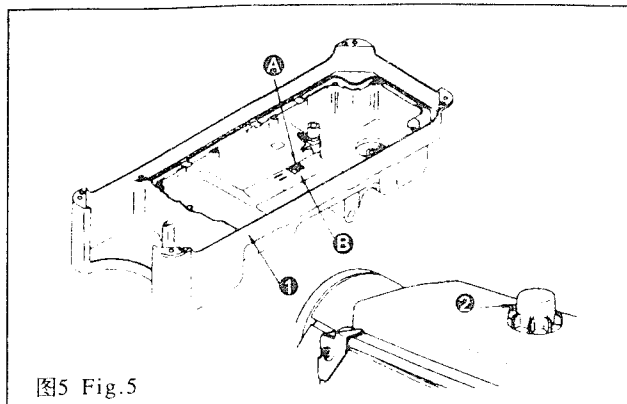
3. ATTACHING THE NEEDLE (Fig.7)

* 在装机针前，必须切断电动机电源。

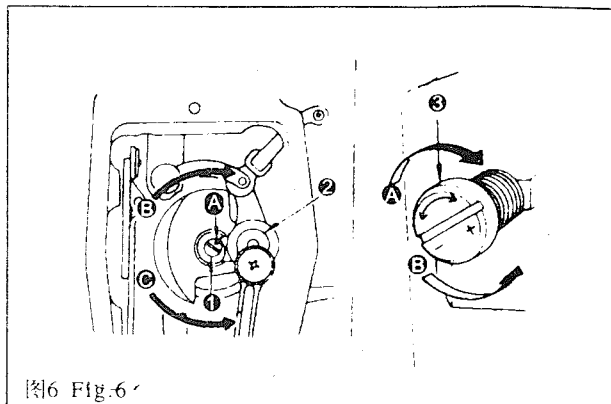
标准用针为DB×1#14。机针有各种编号，根据使用线的粗细和缝料来选择适当的机针。

- 1) 转动上轮使针杆上升到最高位置。
- 2) 旋松支针螺钉②，使机针①的凹弧部分A正对右方向B。
- 3) 将机针朝箭头方向插入针孔的底部，直至插不进为止。
- 4) 旋紧支针螺钉②。
- 5) 务必使机针的长槽C正对左方向D。

* Turn the motor power OFF before starting to attach the needle.

A needle of DB×1#14 should be used. Select a proper needle size according to the count of thread and the type of material used.

- 1) Turn the handwheel until the needle bar reaches the highest point of its stroke.
- 2) Loosen screw ②, and hold needle ① with its indented part A facing exactly to the right in direction B.
- 3) Insert the needle in the direction of the arrow until it will go no further.
- 4) Securely tighten screw ②.
- 5) Check that long groove C of the needle is facing exactly to the left in direction D.



图7 Fig.7

4. 梭心的装法(图8)

4. SETTING THE BOBBIN INTO THE BOBBIN CASE (Fig.8)

- 1) 拿住梭子, 将梭心装入梭子内。
 - 2) 把线从梭子上的线槽A中穿过, 朝B方向拉出。这样, 线通过夹线簧下从线孔B处引出。
 - 3) 拉底线C时, 梭心应按箭头方向转动。
- 1) Hold the bobbin in a way that the thread open end is directed to the left as observed from you, and set the bobbin into the bobbin case.
 - 2) Pass the thread through thread slit A, and pull the thread in direction B. BY so doing, the thread will pass under the tension spring and come out from notch B.
 - 3) Check that the bobbin rotates in the direction of the arrow when thread C is pulled.

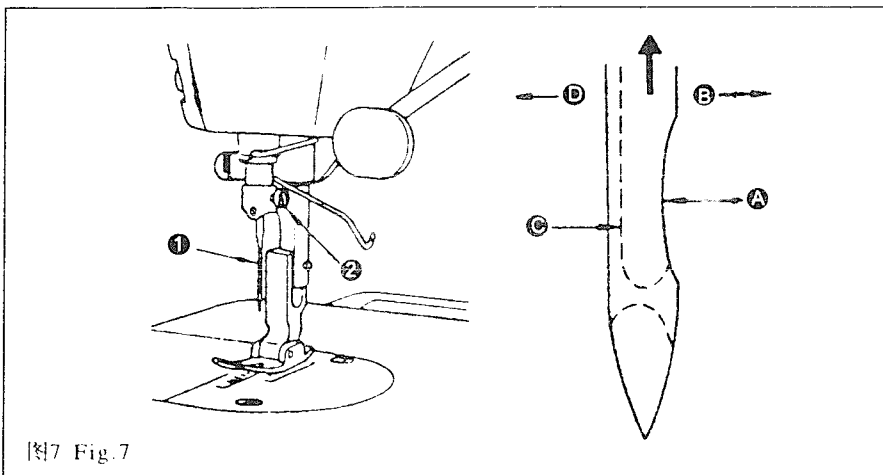
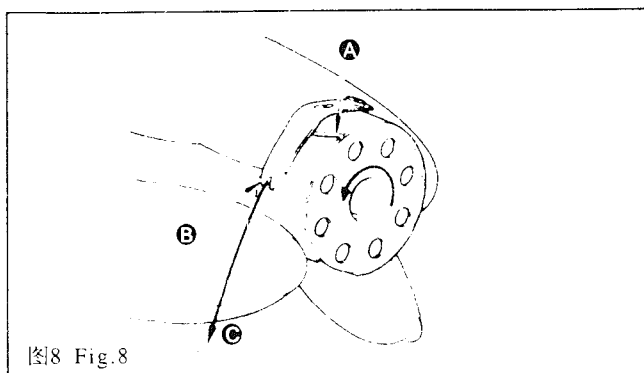

5. 面线的穿法(图9)

5. THREADING THE MACHINE HEAD (Fig.9)

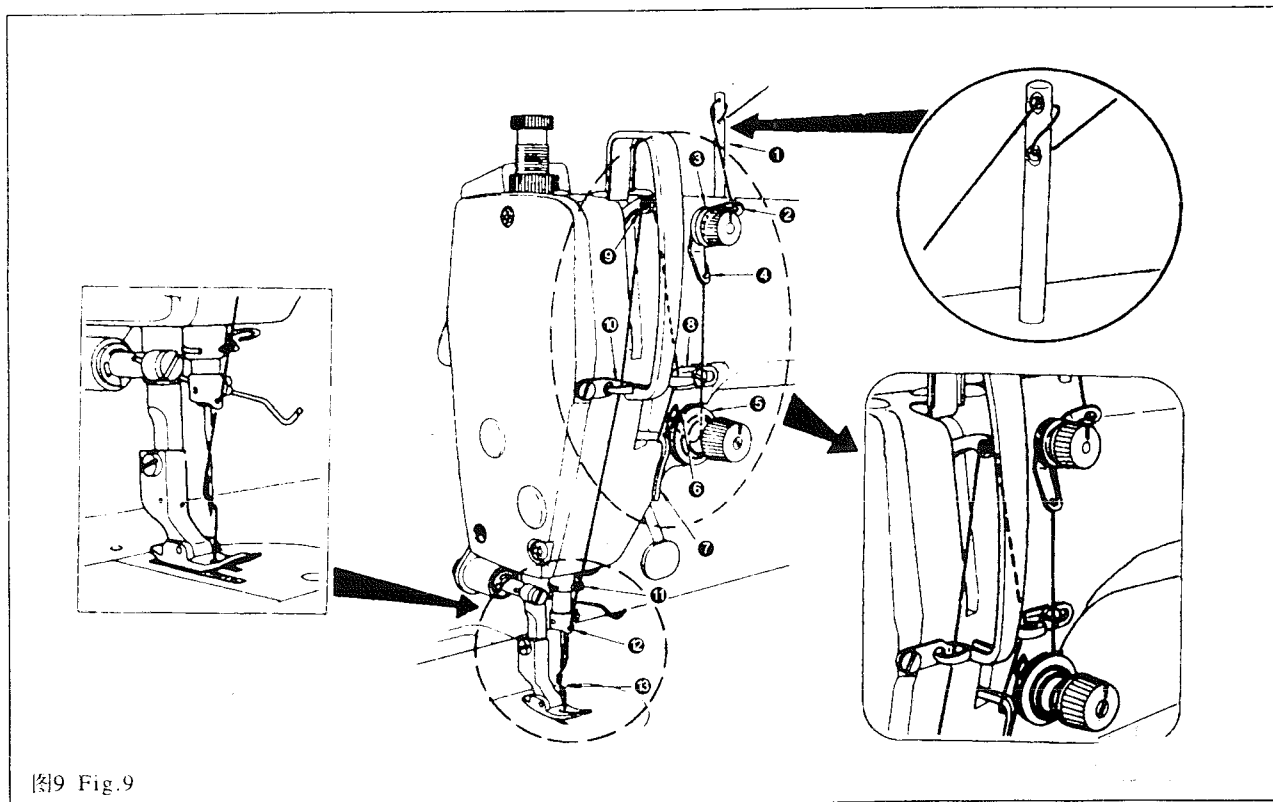

6. 针距的调节(图10)

6. ADJUSTING THE STITCH LENGTH (Fig.10)

- 1) 将送料距旋钮①朝箭头方向转动，旋至所需数字对准机壳上的刻点A。
 - 2) 旋钮上的刻度数字用毫米表示。
 - 3) 当你想缩短线迹长度时，把倒送料扳手②朝箭头方向压的同时，转动送料距旋钮。
- 1) Turn stitch length dial ① in the direction of the arrow, and align the desired number to marker dot A on the machine arm.
 - 2) The dial calibration is in millimeters.
 - 3) When you want to decrease the stitch length, turn stitch length dial ① while pressing feed lever ② in the direction of the arrow.

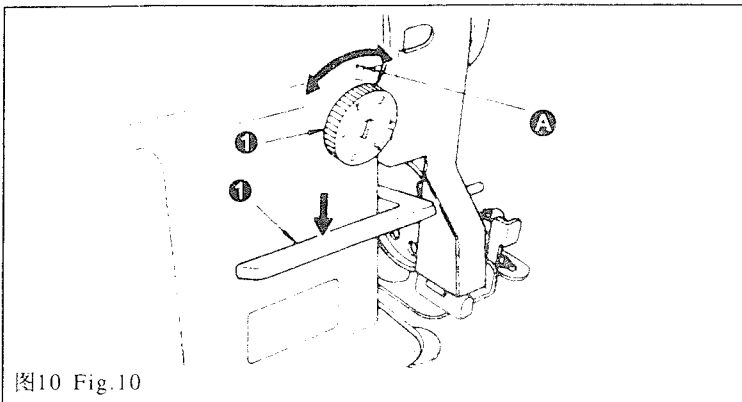

7. 夹线器(图11)

7. THREAD TENSION (Fig.11)

1. 面线张力的调节:

- 1) 若将上夹线螺母①朝顺时针方向(即A方向)转动时，剪线后，留在针孔处线的长度就会短些。
- 2) 若朝逆时针方向(即B方向)转动时，则线将会长些。
- 3) 若将夹线螺母②朝顺时针方向(即C方向)转动时，面线张力将增大。
- 4) 若朝逆时针方向(即D方向)转动时，面线张力将减小。

2. 底线张力的调节:

- 1) 若将梭子上底线张力调节螺钉③朝顺时针方向(即E方向)转动时，底线张力将增大。
- 2) 若朝逆时针方向(即F方向)转动时，底线张力将减小。

1. Adjusting the needle thread tension

- 1) As you turn thread tension No.1 nut ① clockwise (in direction **A**), the thread remaining on the needle after thread trimming will be shorter.
- 2) As you turn nut counterclockwise (in direction **B**), the thread length will be longer.
- 3) As you turn thread tension No.2 nut ② clockwise (in direction **C**), the needle thread tension will be increased.
- 4) As you turn nut ② counterclockwise (in direction **D**), the needle thread tension will be decreased.

2. Adjusting the bobbin thread tension

- 1) As you turn tension adjust screw ③ clockwise (in direction ⑤), the bobbin thread tension will be increased.
- 2) As you turn screw ③ counterclockwise (in direction ⑥), the bobbin thread tension will be decreased.

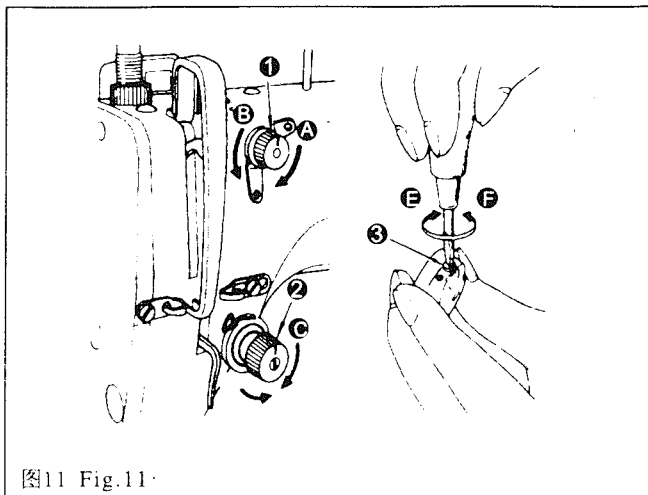

8. 挑线簧(图12) 8. THREAD TAKE-UP SPRING (Fig.12)

1. 改变挑线簧①的摆动量:
 - 1) 旋松定位螺钉②。
 - 2) 把夹线螺钉③朝顺时针方向(即A方向)转动时,挑线簧的摆动量将增大。
 - 3) 把夹线螺钉朝逆时针方向(即B方向)转动时,挑线簧的摆动量将减小。
 2. 改变挑线簧①的张力:
 - 1) 旋松定位螺钉②,并转动夹线螺钉③。
 - 2) 旋松定位螺钉④。
 - 3) 把夹线螺钉③朝顺时针方向(即A方向)转动时,挑线簧的张力将增大。
 - 4) 把夹线螺钉③朝逆时针方向(即B方向)转动时,挑线簧的张力将减小。
1. Changing the stroke of thread take-up spring①
 - 1) Loosen setscrew ②。
 - 2) As you turn tension post ③ clockwise (in direction A), the stroke of the thread take-up spring will be increased.
 - 3) As you turn the knob counterclockwise (in direction B), the stroke will be decreased.
 2. Changing the pressure of thread take-up spring①
 - 1) Loosen setscrew ②, and remove tension post ③。
 - 2) Loosen setscrew ④。
 - 3) As you turn tension post ③ clockwise (in direction A), the pressure will be increased.
 - 4) As you turn the post counterclockwise (in direction B), the pressure will be decreased.



图12 Fig.12

9. 压脚扳手(图13)

9. HAND LIFTER (Fig.13)

- 1) 停车后，将压脚扳手①朝A方向转动，使压脚抬起。
 - 2) 压脚的抬起量约为5.5毫米。
 - 3) 当压脚扳手①朝B方向转动时，压脚将放回原来位置。
 - 4) 对膝提压脚而言，压脚的抬起量约为10毫米，最大抬起量约为13毫米。
- 1) To stop the machine with its presser foot up, turn hand lifter ① in direction A.
 - 2) The presser foot will go up about 5.5mm and stop.
 - 3) The presser foot will go back to its original position when hand lifter ① is turned down in direction B.
 - 4) Using the knee lifter, you can get the standard presser foot lift of about 10mm and a maximum lift of about 13mm.

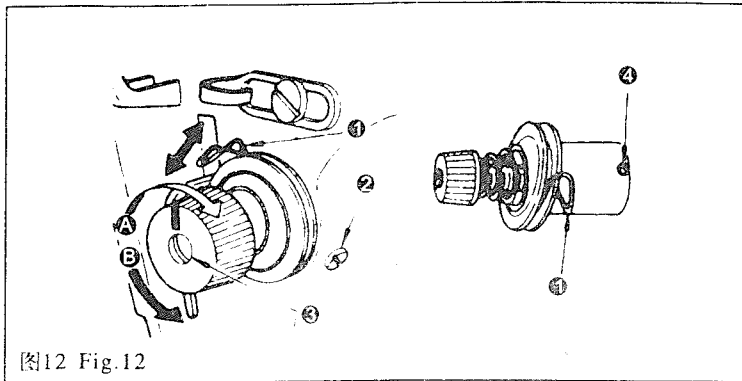

图13 Fig.13

10. 压脚压力的调节(图14)

10. PRESSER FOOT PRESSURE (Fig.14)

- 1) 旋松调压螺母②，顺向(即A方向)转动压脚调节螺钉，压力将增强。
 - 2) 逆向(即B方向)转动压脚调节螺钉，压力将减弱。
 - 3) 调节后，旋紧调压螺母②。
 - 4) 对一般布料而言，压脚调节螺钉的标准高度为29-32毫米(5公斤)左右。
- 1) Loosen nut ②, As you turn presser spring regulator ① clockwise (in direction A), the presser foot pressure will be increased.
 - 2) As you turn the presser spring regulator counterclockwise (in direction B), the pressure will be decreased.
 - 3) After adjustment, tighten nut ②.
 - 4) For general fabrics, the standard height of the presser spring regulator is 29 to 32 mm (5kg).

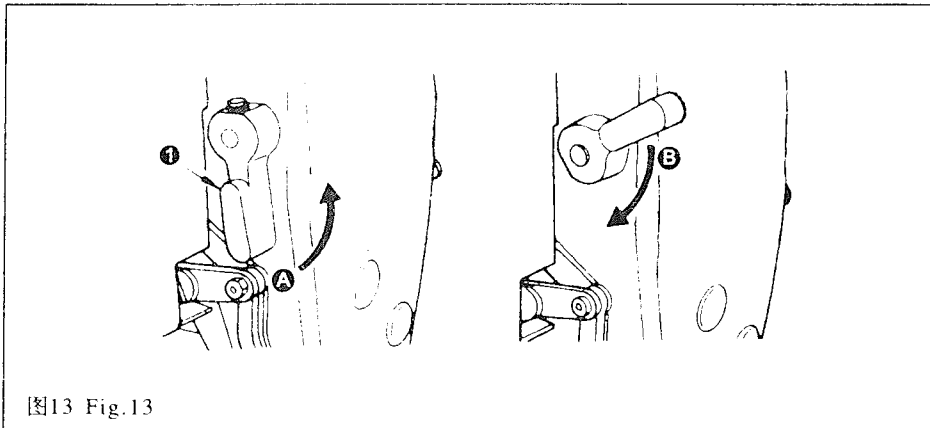
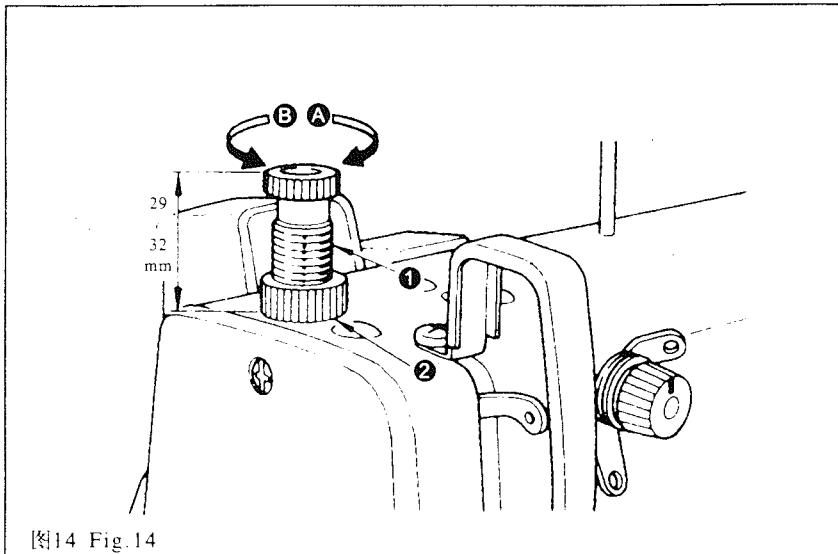

11. 送料牙的高度(图15)

11. HEIGHT OF THE FEED DOG (Fig. 15)

- 1) 送料牙应比针板高出0.8-0.9毫米。
 - 2) 在缝薄料的情况下，如果送料牙过分凸出会导致缝料起皱。(推荐送料牙突出量：0.7-0.8毫米)
 - 3) 调节送料牙的高度：
 - ①旋松抬牙叉形曲柄①的坚固螺钉②。
 - ②上下移动牙架进行调节。
 - ③旋紧曲柄螺钉②。
- A 送料牙 b 针板
- 1) The feed dog is factory-adjusted so that it juts out from the throat plate surface 0.8mm to 0.9mm.
 - 2) If the feed dog juts out too much, puckering may result when sewing light-weight materials. (Recommended protrusion: 0.7mm to 0.8mm)

- 3) To adjust the height of the feed dog:
- (1) Loosen screw ② of crank ①.
 - (2) Move the feed bar up or down to make adjustment.
 - (3) Securely tighten screw ②.
- a Feed dog b Throat plate



图15 Fig.15

12. 针与旋梭的关系(图16)

12. NEEDLE-TO-HOOK RELATIONSHIP (Fig.16)

1. 针与旋梭的关系应配合如下:

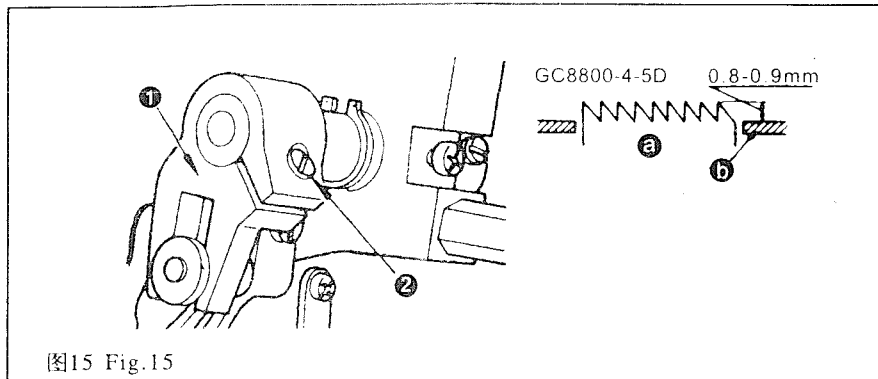
- 1) 转动上轮, 使针杆位于最低点, 再旋松针杆连接柱定位螺钉①。
- * 针杆高度的确定
- 2) 使针杆②上的刻线A对准针杆下衬套③的下端, 然后旋紧针杆连接柱定位螺钉①。
- * 旋梭位置的确定
- 3) 旋松两只旋梭定位螺钉, 并转动上轮, 使针杆②的下刻线B对准针杆下衬套③的下端。
- 4) 在上述状态下, 使旋梭的勾线尖⑤对准机针④的中心, 针与旋梭的间隙为0.04-0.1mm, 然后拧紧旋梭坚固螺钉。
- * 旋梭原来用什么型号, 调换后, 也请使用原来的型号。

1. Adjust the timing between the needle and the hook as follows:

- 1) Turn the handwheel to bring the needle bar down to the lowest point of its stroke, and loosen setscrew ①.
- * Adjusting the needle bar height.
- 2) Align marker line A on needle bar ② with the bottom end of needle bar lower bushing ③, then tighten setscrew ①.
Adjusting position @ of the hook
- 3) Loosen the two hook setscrews, turn the hand wheel, and align marker line B on ascending needle bar ② with the bottom end of needle bar lower bushing ③.
- 4) After making the adjustments mentioned in the above steps align hook blade point ⑤ with the center of needle ④. Provide a clearance of 0.04mm to 0.1mm between the needle and the hook. Then securely, tighten the hook setscrews.

* Note that the type of hook to be substituted for, when replacing the hook, Shall be in conformity with the very type of the hook installed in the sewing machine of original assemblage.

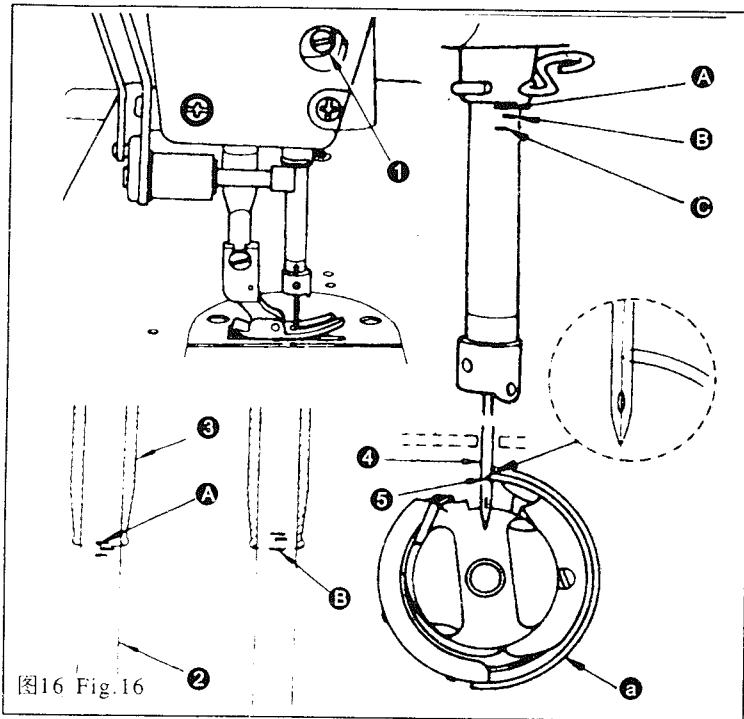

13. 压杆高度的调节(图17)

13. ADJUSTING THE HEIGHT OF THE PRESSER BAR (Fig.17)

1) 旋松压杆导架紧固螺钉①，调节压杆高度与压脚角度。

2) 调节后，拧紧紧固螺钉。

1) Loosen setscrew ①, and adjust the presser bar height and the angle of the presser foot.

2) After adjustment, securely tighten the setscrew.

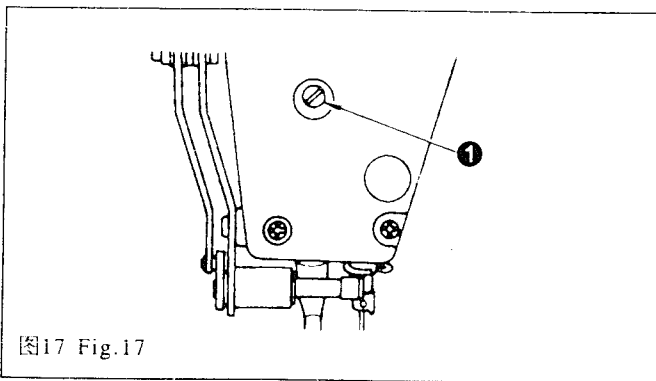

14. 挑线杆挑线量的调节(图18)

14. ADJUSTING THE THREAD TAKE-UP STROKE (Fig.18)

- 1) 缝制厚料时, 应将右线钩①朝左方向A移动, 以增大挑线量。
- 2) 缝制薄料时, 应将右线钩①朝右方向B移动, 以减小挑线量。
- 1) When sewing heavy-weight materials, move thread guide ① to the left in direction A to increase the length of thread pulled out by the thread take-up.
- 2) When sewing light-weight materials, move thread guide ① to the right in direction B to decrease the length of thread pulled out by the thread take-up.

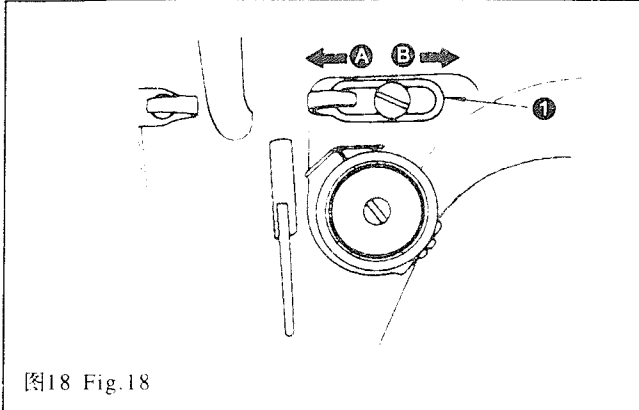

15. 皮带罩和绕线器的装法(图19、图20)

15. INSTALLING THE BELT COVER AND THE BOBBIN WINDER (Fig.19, Fig.20)

1. 安装程序:

- 1) 在台板上钻四只木螺钉导孔A、B、C、D。
- 2) 将罩壳支柱①装入机壳的螺孔内。
- 3) 将上轮前罩壳③从后斜方装入, 使上轮套进上轮前罩壳③的孔内。
- 4) 将上轮后罩壳②放置在导孔C D上。
- 5) 用螺钉和垫圈④⑤⑥, 将上轮前罩壳③固定在车壳上。此时的螺钉紧固扭矩请控制在螺钉④为30kgfcm, 螺钉⑤为25kgfcm, 即使紧固扭矩超过以上程度, 也无效果。
- 6) 盖上上轮前罩壳盖板⑦。
- 7) 将上轮后罩壳②向后方移动, 在上轮后罩壳②的橡胶部份碰到上轮前罩壳③时, 再移动0.5-1mm, 将其用木螺钉和垫圈固定。
- 8) 用木螺钉将绕线器⑧固定在导孔A和B上。

1. Installing procedure

- 1) Drill four wooden screw guide holes, A, B, C and D in the machining table.
- 2) Insert support ① in the tapped hole in the arm.
- 3) Install the front belt cover ③, get the hand wheel in the middle of the hole.
- 4) Install the back belt cover ② at C and D.
- 5) Using the screws ④, ⑤ and washer ⑥, fix, the front belt cover ③ on the support the tightening torque for the screw ④ is about 30 kgfcm, for the screw ⑤ is about 25 kgfcm.

- 6) Fix the civer ⑦.
- 7) Move the back belt cover ② backward until its rubber touches the front belt cover ③, then move further more 0.5-1 mm, fix it using the wooden screws and washers.
- 8) Fix bobbin winder ⑧ at A and B using the wooden screws.

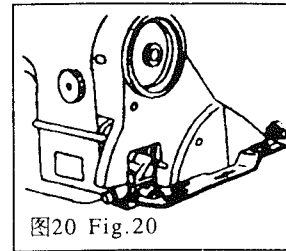
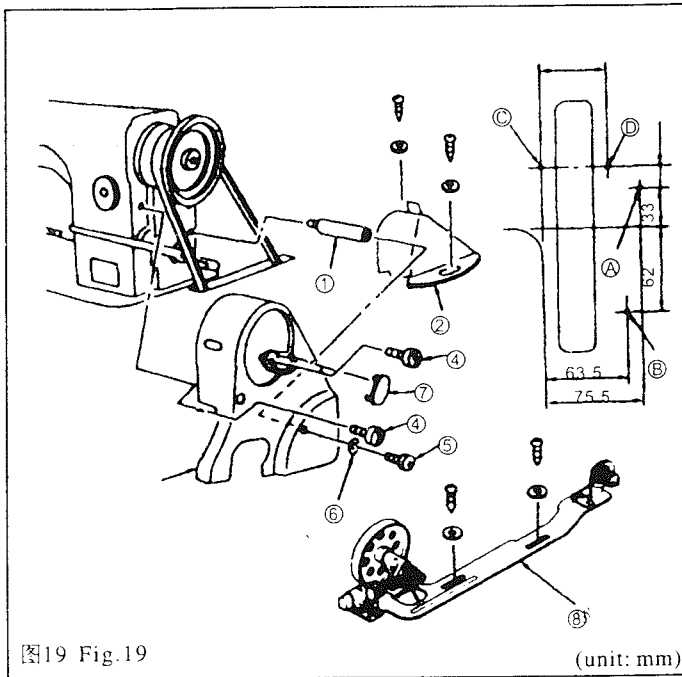

16. 膝提高度的调节(图21、图22) 16. ADJUSTING THE HEIGHT OF THE KNEE LIFTER (Fig.19, Fig.20)

- 1) 用膝提时的标准压脚高度是10毫米。
- 2) 用膝提调整螺钉①可以调节压脚提升量至13毫米。
- 3) 当压脚提升量超过10毫米时，不能使处于最低位置的针杆②的底端与压脚③相碰。
- 1) The standard height of the presser foot lifted using the knee lifter is 10mm.
- 2) You can adjust the presser foot lift up to 13mm using knee lifter adjust screw①.
- 3) When you have adjusted the presser foot lift to over 10mm, be sure that the bottom end of needle bar ② in its lowest position does not hit presser foot ③.

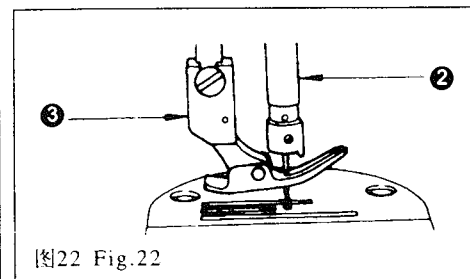
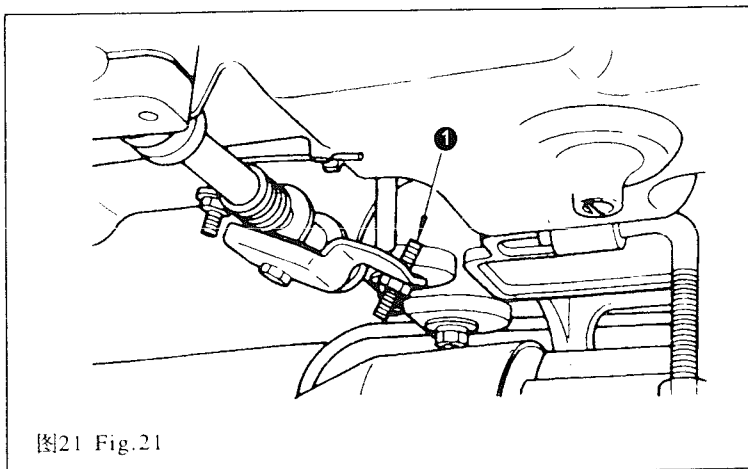

17. 线架的装法(图23)

17. INSTALLING THE THREAD STAND (Fig.23)

- 1) 安装线架部件，并将它插入缝纫机台板孔里。
 - 2) 旋紧线架杆下节螺母①固定线架装置。
- 1) Assemble the thread stand unit, and insert it in the hole in the machine table.
 - 2) Tighten locknut ① to fix the thread stand.

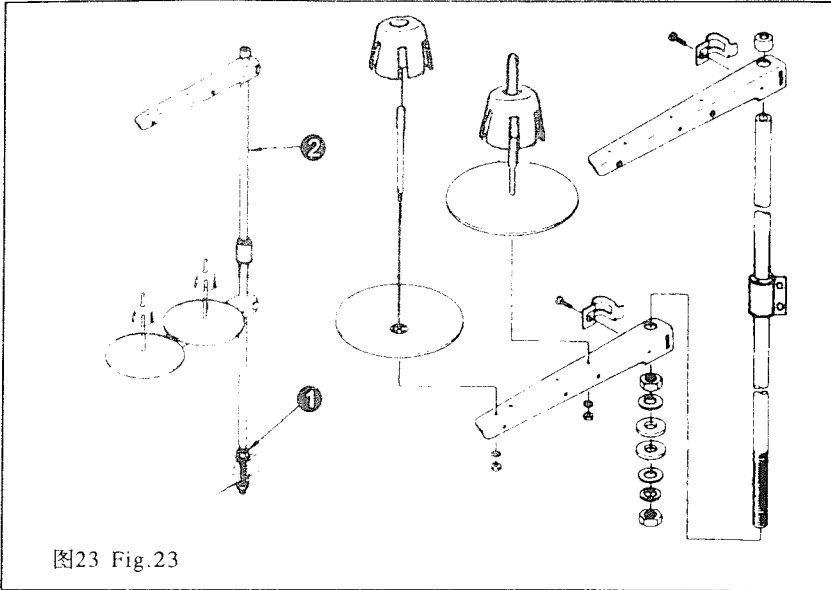

18. 踏板操作(图24)

18. PEDAL OPERATION (Fig.24)

1. 踏板分四个阶段操作:
 - 1) 将踏板朝前轻踏，则低速缝纫。(图示B)
 - 2) 进一步朝前踏，就是高速缝纫。(图示A)(如果有起始倒回缝模式时，则待起始倒回缝结束后，开始高速缝纫。)
 - 3) 当踏板恢复到原始状态时，机器停止运转(上停针或下停针)。(图示C)
 - 4) 将踏板朝后踏，执行剪线动作。(图示E)
- * 如果机器装有自动抬压脚，那么踏板位置应在机器停止和剪线动作间的一档。当你轻轻朝后踏，压脚将会上升(图示D)，并且只有将踏板再朝后踏，才会执行剪线动作。
 - * 在起始倒回缝中，将踏板回复到中间位置，机器完成倒回缝后停止。
 - * 在执行高速缝纫或低速缝纫时，将踏板朝后踏，剪线动作能正常执行。
 - * 机器开始剪线后，即使将踏板回复到中间位置，剪线动作也能完成。
 - * 当机器停止，针处于下针位状态时，如果要使针处于上针位，请将踏板朝后踏一次。

1. The pedal is operated in the following for steps:

- 1) The machine runs at low sewing speed when you lightly depress the front part of the pedal. (B)
 - 2) The machine runs at high sewing speed when you further depress the front part of the pedal. (A) (If the automatic reverse feed stitching has been preset, the machine runs at high speed after in completes reverse feed stitching.)
 - 3) The machine stops (with its needle up or down) when you reset the pedal to its original position. (C)
 - 4) The machine trims threads when you fully depress the back part of the pedal. (E)
- * If your machine is provided with the Auto-lifter (AK-31), an addition step is given between the machine stop and thread trimming step.

The presser foot goes up when you lightly depress the back part of the pedal (D), and if you further depress the back part, the thread trimmer is actuated.

- If you reset the pedal to its neutral position during the automatic reverse feed stitching at seam start, the machine stops after it completes the reverse feed stitching.
- The machine will perform normal thread trimming even if you depress the back part of the pedal immediately following high or low speed sewing.
- The machine will completely perform thread trimming even if you reset the pedal to its neutral position immediately after the machine started thread trimming action.
- When the machine stops with its needle down, and if you want to bring the needle up, depress the back part of the pedal once.

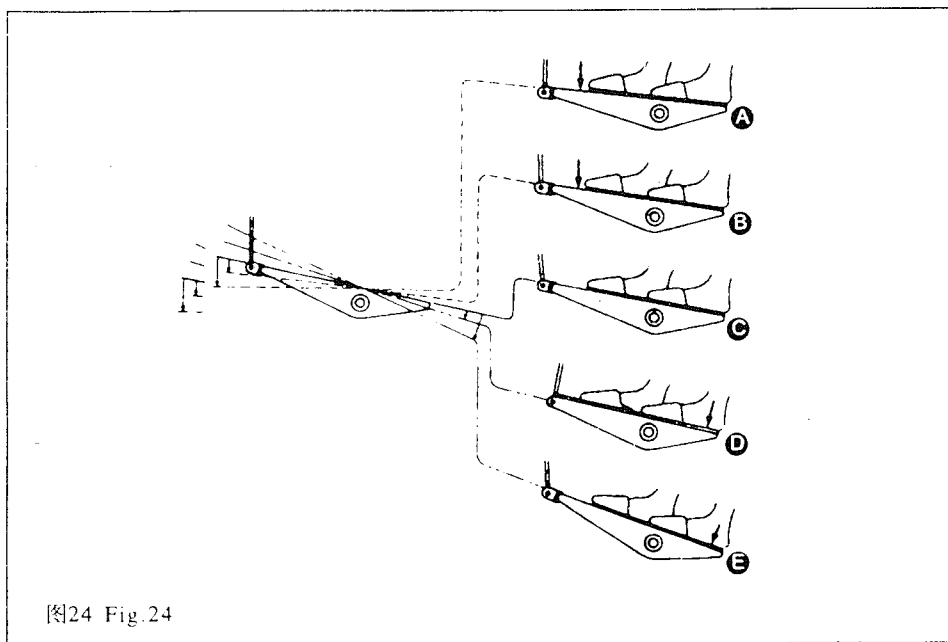

19. 送料相位的调节(图25)

19. ADJUSTING THE FEED TIMING (Fig.25)

- 1) 在标准相位情况下，将送料偏心轮①上的定位螺钉A与上轴挡圈②的定位螺钉B对齐。
 - 2) 调整时，旋松送料偏心轮上两个定位螺钉③，将送料偏心轮调到适当的位置上，然后拧紧定位螺钉。
 - 3) 为了防止缝料的潜移，要加快送料相位，可将送料偏心轮朝箭头方向调整。
 - 4) 为了增大线迹的紧密度，要减慢送料相位，可将送料偏心轮朝箭头相反方向移动。
 - 5) 千万小心不要将送料偏心轮移动得太多，不然的话，会造成断针现象。
- 1) To obtain the standard feed timing, align setscrew (A) on feed eccentric cam (1) with setscrew (B) on main shaft thrust collar (2).
 - 2) To make adjustment, loosen two setscrews (3) to release the feed eccentric cam, properly position the eccentric cam. Then retighten the setscrews.
 - 3) To advance the feed timing in order to prevent uneven material feed, move the feed eccentric cam in the direction of the arrow.
 - 4) To delay the feed timing in order to increase stitch tightness, move the feed eccentric cam in the opposite direction from the arrow.
 - 5) Be careful not to move the feed eccentric cam too far, or else needle breakage may result.

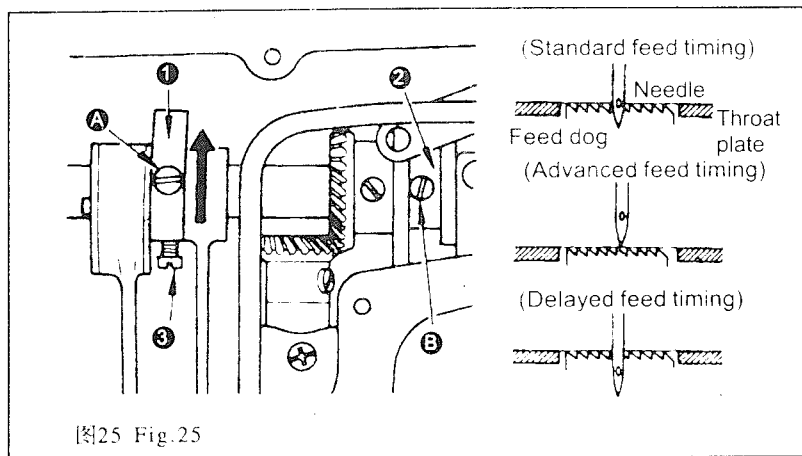

20. 送料牙的倾斜(图26)

20. TILT OF THE FEED DOG (Fig.26)

- 1) 标准的倾斜，是牙架销上的刻点A与牙架座①上的刻点B对齐。
 - 2) 为了防止浮线，要送料方向高，则旋松固定螺钉，用螺丝刀把牙架销朝箭头方向转动90°。
 - 3) 为了防止缝料的潜移，要送料方向向低，则牙架销朝箭头相反方向转动90°。
- * 注意：
无论什么时候，调节送料牙的倾斜，送料牙的高度将会变化。所以，在调整之后，请再次确认送料牙的高度。

- 1) The standard tilt (horizontal) of the feed dog is obtained when marker dot (A) on the feed bar shaft is aligned with marker dot (B) on feed rocker (I).
- 2) To tilt the feed dog with its front up in order to prevent puckering, loosen the setscrew, and turn the feed bar shaft 90 degrees in the direction of the arrow.
- 3) To tilt the feed dog with its front down in order to prevent uneven material feed, turn the feed bar shaft 90 degrees in the opposite direction from the arrow.

* Precaution

Whenever the feed dog tilt is adjusted, the feed dog height will be changed. So, it is necessary to check the height after tilt adjustment.

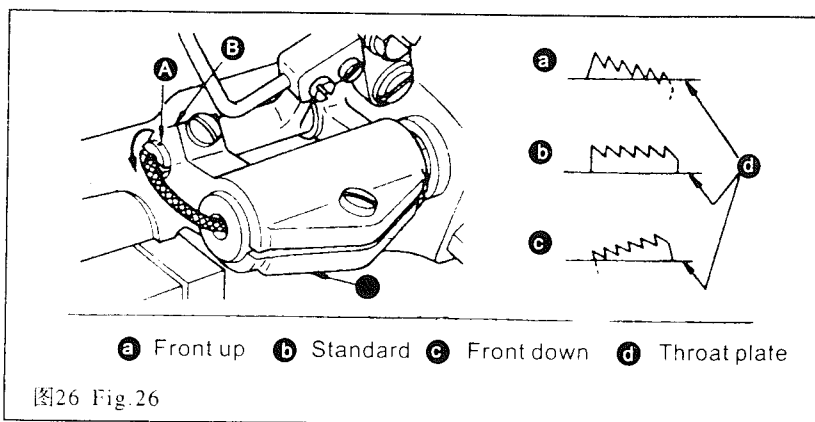

21. 定刀装置(图27)

21. COUNTER KNIFE (Fig.27)

1. 定刀刃口磨损时，要尽快拆下定刀①研磨修整，按图示C的标准正确安装。
 - 1) 如果将定刀从标准位置朝A方向移动，剪线后线的长度就比标准的长。
 - 2) 如果朝B方向移动，剪线后线的长度就比标准的短。
 - a. 动刀 b. 机针中心 c. 标准距离: 4.0mm
1. When the knife sharpness has deteriorated, sharpen counter knife (I) as illustrated in Fig. (C), and properly reinstall it.
 - 1) If the mounting position of the counter knife is moved in direction (A) from the standard mounting position, the thread length after thread trimming will be increased accordingly.
 - 2) If the mounting position is moved in direction (B), the thread length will be decreased accordingly.
 - a. Moving knife
 - b. Center of needle
 - c. Standard: 4.0mm



图27 Fig.27

22. 停针位置的调整(图28、图29)

22. ADJUSTING THE NEEDLE STOP POSITION (Fig.28, Fig.29)

1. 剪线后的上停针位置

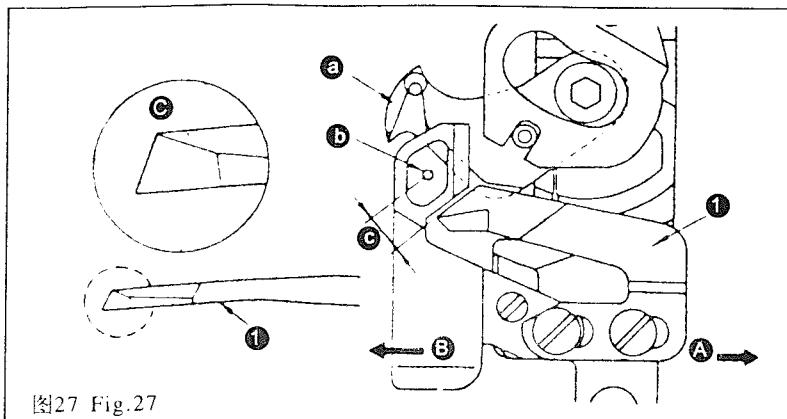
1. 标准的上停针位置是车壳上的红刻点A与上轮上的白刻点B对齐。
- 2) 要使上停针位置有所变化，旋松螺钉①，就可在长槽范围内调整。

①若螺钉朝C方向移动，则停针快。

②若螺钉朝D方向移动，则停针慢。

* 注意：

在旋松螺钉①的时候，请不要起动机器。此外，螺钉①只要旋松即可，不要拆下。

2. 下停针位置

1. 当踏板从前踏状态回到中间位置时，针杆处于下停针位置，可按下列方法调整：

要使下停针位置有所变化，旋松螺钉②，就可在长槽范围内调整。

螺钉朝A方向移动，停针快。螺钉朝B方向移动，停针慢。

* 注意：

在旋松螺钉②的时候，请不要起动机器。此外，螺钉②只要旋松即可，不要拆下。

1. Stop position after thread trimming

1. The standard needle stop position is obtained by aligning red marker dot (A) on the machine arm with white marker dot (B) on the handwheel.

- 2) Stop the needle in its highest position, loosen screw ① to perform adjustment within the slot of the screw.

① The needle stop timing is advanced if you move the screw in direction (C).

② The needle stop timing is delayed if you move the screw in direction (D).

Precaution

Do not operate the machine with screw ① loosened. Just loosen the screw, and do not remove it.

2. Lower stop position

- 1) The lower needle stop position when the pedal is returned to the neutral position after the front part of the pedal is depressed can be adjusted as follows:

Stop needle ① in its lowest position, loosen screw ②, and make adjustment within the slot of the screw.

Moving the screw in direction ①, advances the needle stop timing. Moving the screw in direction ② delays the timing.

* Precaution

Do not operate the machine with screw ② loosened. Just loosen the screw, and do not remove it.



图28 Fig.28



图29 Fig.29

23. 踏板压力与行程(图30)

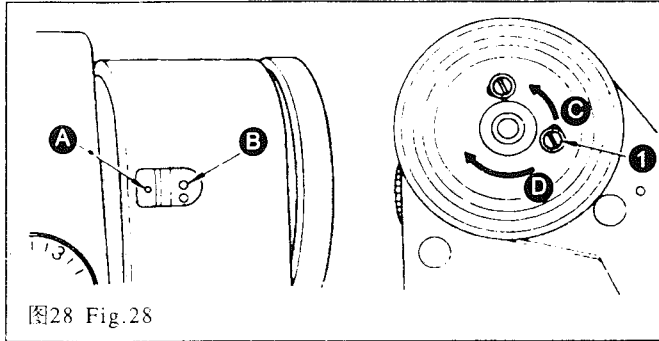
23. PEDAL PRESSURE AND PEDAL STROKE (Fig.30)

1. 踏板前踏压力的调整:

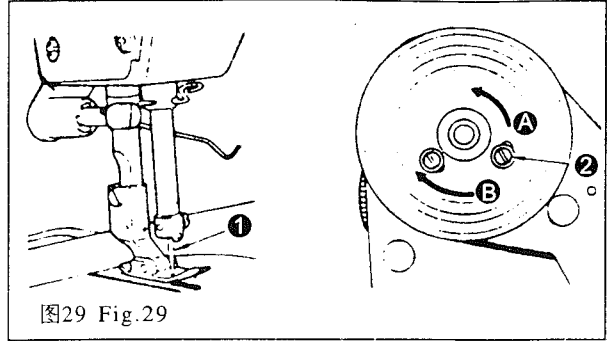
- 1) 调换踏板调节弹簧①的位置就能进行调整。
- 2) 挂在左侧，压力减小。
- 3) 挂在右侧，压力增大。

2. 踏板后踏压力的调整:

- 1) 用后踏调节螺钉②能进行调整。
- 2) 拧紧调节螺钉，压力增大。
- 3) 旋松调节螺钉，压力减小。

3. 踏板行程的调整:

- 1) 将拉杆③换到左侧孔内，行程减小。

1. Adjusting the pressure required to depress the front part of the pedal

- 1) This pressure can be changed by altering the mounting position of pedaling pressure adjust sping ①.
- 2) This pressure decreases when you hook the spring on the left side.
- 3) The pressure increases when you hook the spring on the right side.

2. Adjusting the pressure required to depress the back part of the pedal

- 1) This pressure can be adjusted using regulator screw ②.
- 2) The pressure increases as you turn the regulator screw in.
- 3) The pressure decreases as you turn the screw out.

3. Adjusting the pedal stroke

- 1) The pedal stroke decreases when you insert connecting rod ③ into the left hole.



图30 Fig.30

24. 踏板的调整(图31) 24. ADJUSTMENT OF THE PEDAL (Fig.31)

1. 拉杆位置的调整:

1) 左右移动踏板调节板③，将踏板曲柄①和拉杆部件②垂直连接。

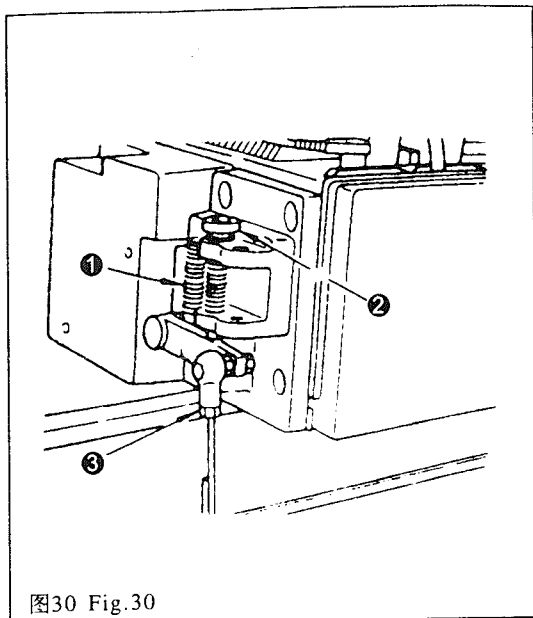
2. 踏板角度的调整:

1) 踏板的倾斜，可以根据拉杆长度的调节自由改变。

2) 旋松螺钉④，就可以调节拉杆②的长度。

1. Installing the connection rod

1) Move pedal ③ to the right or left as illustrated by the arrows so that motor control lever ① and connecting rod ② are straightened.

2. Adjusting the pedal angle

1) The pedal tilt can be freely adjusted by changing the length of the connecting rod.

2) Loosen adjust screw ④, and adjust the length of connecting rod ②.



图31 Fig.31

25. 手触倒缝装置(图32)

25. ONE-TOUCH TYPE REVERSE FEED STITCHING MECHANISM (Fig.32)

1. 使用方法:

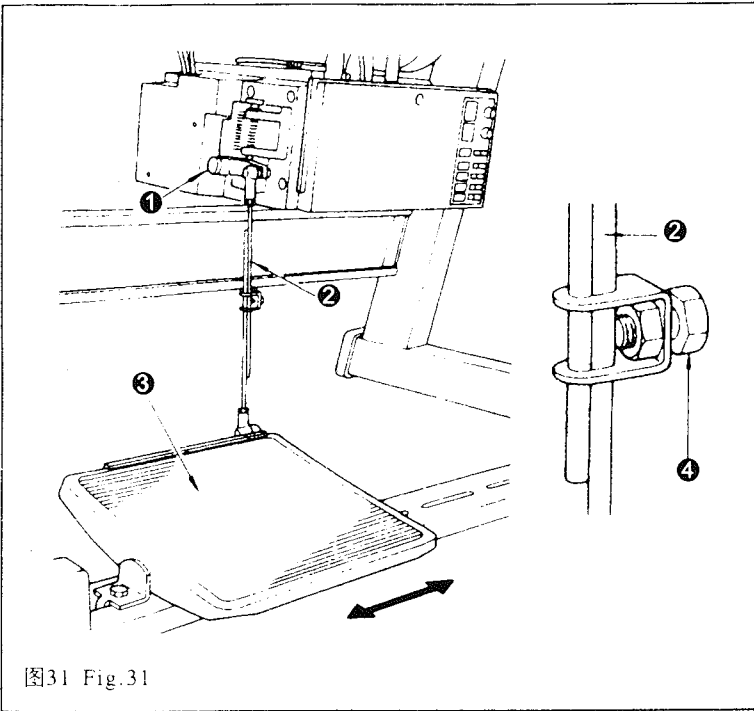
- 1) 手按手触倒缝开关①, 机器执行倒缝动作。
- 2) 机器执行自动倒缝与手按着开关按钮的时间同步。
- 3) 手离开开关按钮, 机器又重新恢复到顺缝状态。

2. 手触倒缝开关的高度

- 1) 调节手触倒缝开关①的高度, 使之便于操作。
- 2) 旋松螺钉②, 上下移动开关杆就可调整它的高度。

1. How to operate

- 1) The moment switch lever ① is pressed, the machine performs reverse feed stitching.
- 2) The machine performs reverse feed stitching as long as the switch lever is held depressed.
- 3) The machine resumes normal feed stitching the moment the switch lever is released.

2. Height of the switch lever

- 1) Adjust the height of switch lever ① so that it can be easily operated.
- 2) Loosen screw ②, and move the switch lever up or down to adjust its height.



图32 Fig.32

26. 拨线器(图33、图34、图35)

26. WIPER (Fig.33, Fig.34, Fig.35)

1. 拨线器位置

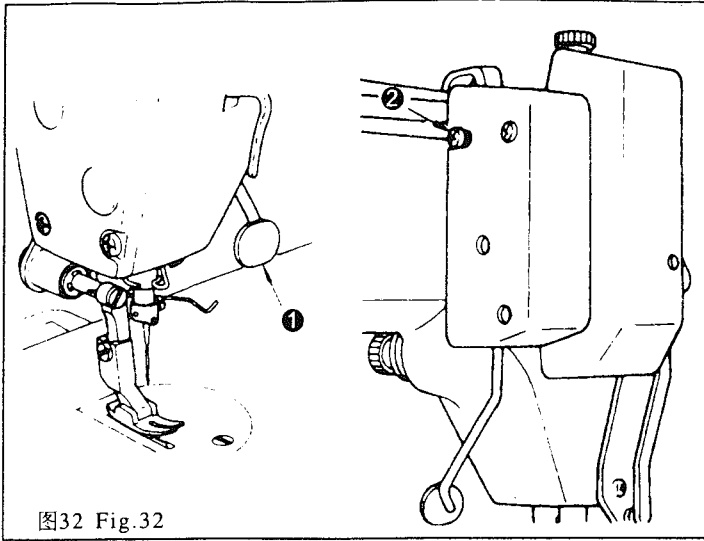
根据缝料厚薄来调整拨线器的位置。调整顺序如下:

- 1) 朝顺缝方向转动上轮, 使上轮上的白刻点①对准车壳上的红刻点②。
- 2) 拨线器杆垂直部位与机针中心的距离为1毫米。
调整完以后拧紧固定螺钉⑤通过螺钉套圈⑥以固定拨线器杆。
- 3) 不需要使用拨线器时, 请切断拨线器开关。

1. Positioning the wiper

Adjust the position of the wiper according to the thickness of the material sewn. The adjustment procedure is as follows:

- 1) Turn the handwheel in the normal direction of rotation to align white marker dot ① on the handwheel with red market dot ② on the machine arm.
- 2) Adjust the distance between the flat part of the wiper and the center of the needle to 1mm.
Tighten wiper adjust screw ⑤ so that the wiper is pressed and fixed by wiper collar ⑥.
- 3) When the wiper is unnecessary, turn wiper switch ⑦ OFF.



图33 Fig.33



27. 规格
27. SPECIFICATIONS

	GC188-M-D型		Model GC188-M-D
缝料	中厚料用	Application	For medium-weight materials
缝速	最大每分钟5000针	Sewing speed	Max.5000 s.p.m.
线迹长度	4mm (最大)	Stitch length	Max.4mm
压脚提升高度 (膝提)	10mm (标准) 13mm (最大)	Presser foot lift (by knee lifter)	100mm (Standard) 13mm (max.)
机针	DB×1#14	Needle	DB×1#14
润滑油	10号白油	Lubrication oil	10 white oil

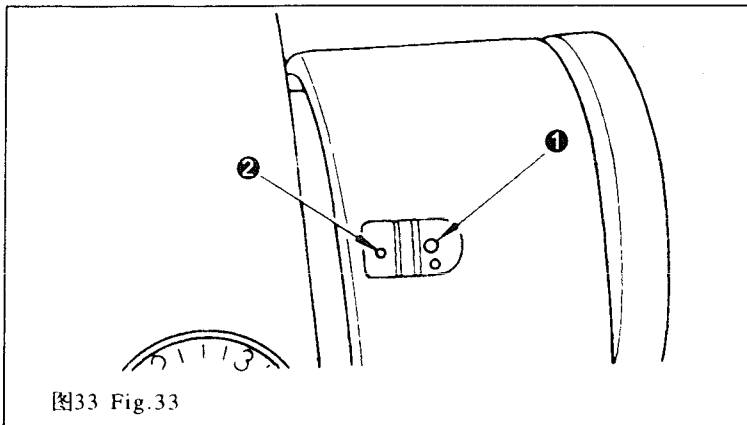
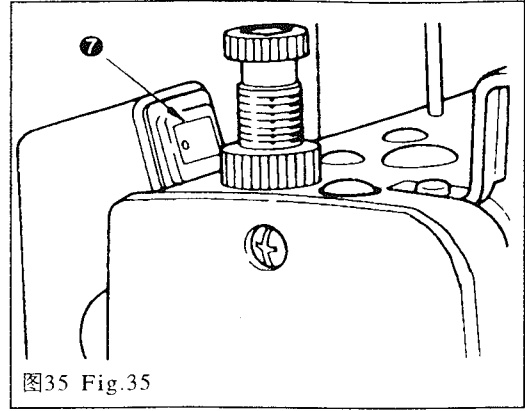
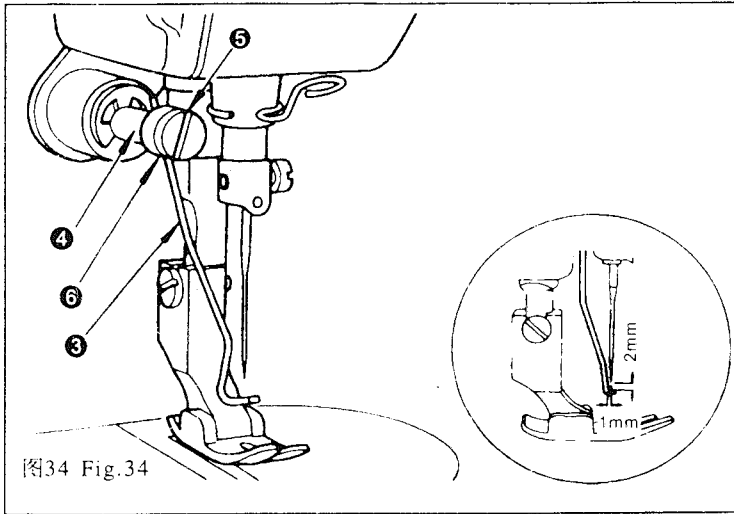
零件样本

Parts Book

GC188-M-D型 (中厚料用)

Model GC188-M-D (For Medium heavy Material)

1、机壳分组件

1.Arm bed components

序号	件号	名 称	Description	数量
Ref.No.	Part No.			Amt.
1	GQ228	型号牌	Model plate	1
2	GX565	型号牌铆钉	Model plate rivet	2
3	GS0548	底板支柱	Bed screw stud	4
4	GK239	后窗板	Side plate	1
5	GR3340	后窗板垫	Gasket	1
6	GS053	后窗板螺钉12/64-28 L=9	Screw 12/64-28 L=9	8
7	GR5685	面板	Face plate arm	1
8	GQ277	面板装饰板	Decorative Plate	1
9	GR5686	面板垫	Gasket	1
10	GS053	面板螺钉12/64-28 L=9	Screw 12/64-28 L=9	3
11	GR1458	面板调节螺孔塞	Rubber plug	2
12	GR1463	针杆曲柄螺孔塞	Rubber plug	1
13	GR3344	挑线连杆销螺孔塞	Rubber plug	2
14	GR3345	送料调节器孔塞	Rubber plug	1
15	GR1464	下轴盲孔塞	Rubber plug	1
16	GR2045	电线过线圈	Rubber bushing	1

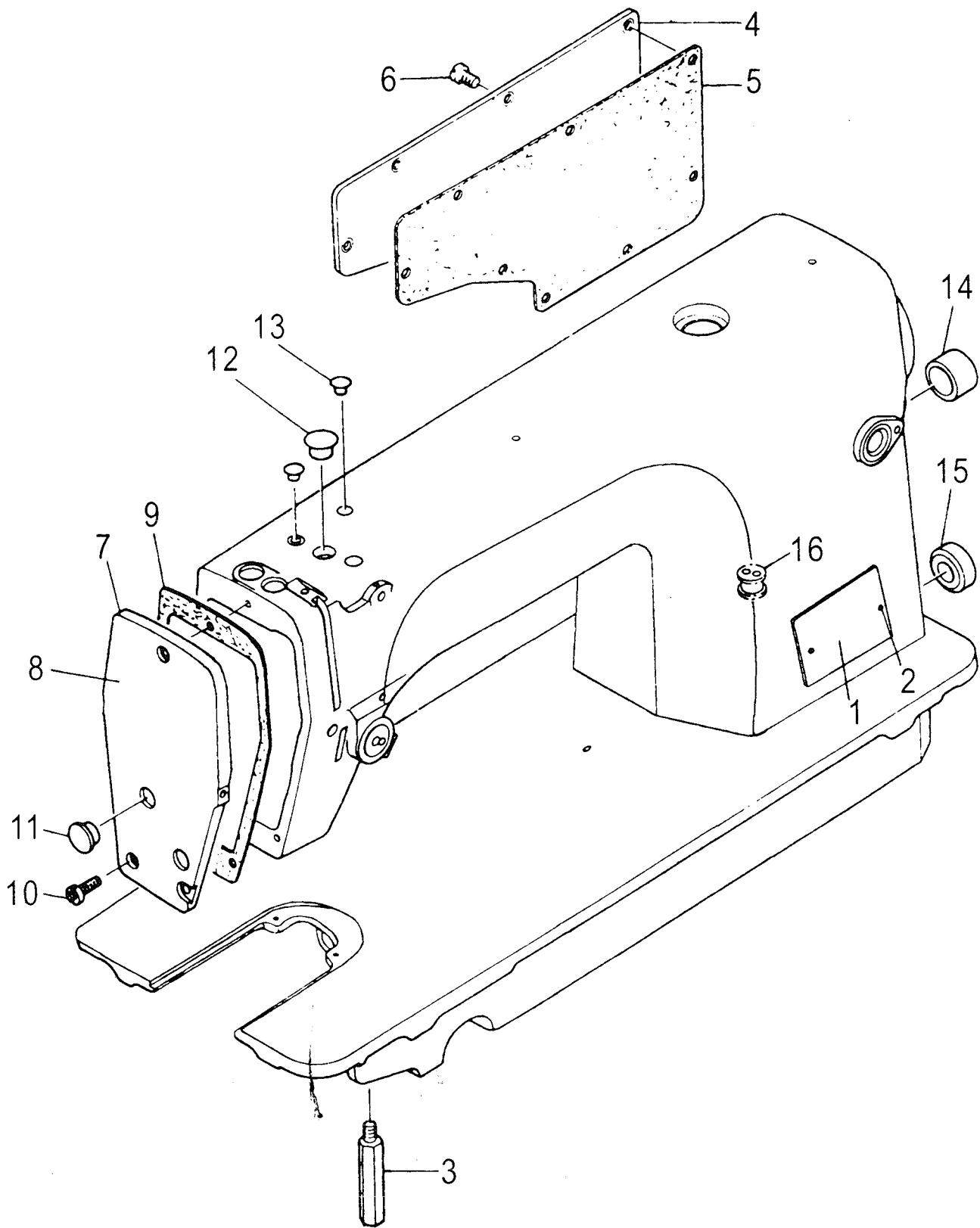

2、上轴、挑线分组件

2.Main shaft & thread take-up components

序号	件号	名 称	数量
Ref.No.	Part No.	Description	Amt
1	GP144	上轮	1
2	GD302	磁钢	2
3	GR2406	磁钢支承架	2
4	GS0219	支承架螺钉11/64-40 L=12	2
5	GR2407	螺钉垫圈	2
6	GS03	上轮螺钉15/64-28 L=15	2
7	GD303/2	上轴传感器部件	1
8	GS0220	上轴传感器安装螺钉	2
9	GR2409	安装螺钉垫圈	2
10	GR2410	电线安装导架	1
11	GS0551	电线安装导架螺钉3/16-28 L=6	1
12	GZ431	上轴	1
13	GR3346	上轴油封	1
14	GO462	上轴后轴套	1
15	GR1469	上轴挡圈	1
16	GS39	上轴挡圈螺钉1/4-40 L=6	1
17	GO463	上轴中轴套	1
18	GS0549	上轴中轴套螺钉15/64-28 L=9	1
19	GO464	上轴前轴套	1
20	GR1470	曲柄油量限制毡	1
21	GX334	曲柄油量调节销	1
22	GO269	曲柄油量调节销套	1
23	GR1471	曲柄油量调节销O形圈	1
24	GH561	针杆曲柄	1
25	GS06	针杆曲柄定位螺钉1/4-40 L=6	1
26	GR1472	定位螺钉O形圈	1
27	GS0550	针杆曲柄紧固螺钉9/32-28 L=16	1
28	GR1473	针杆曲柄护板	1
29	GH563	挑线曲柄	1
30	GS39	挑线曲柄定位螺钉1/4-40 L=6	2
31	GH564/4	挑线杆分部件	1
32	GR3349	挑线杆防油套	1
33	GO270	挑线杆滚针轴承	1
34	GH566	挑线连杆	1
35	GX566	挑线连杆销	1
36	GR3350	挑线连杆销油线	1
37	GS04	挑线连杆销螺钉15/64-28 L=10.5	1
38	GS09	挑线曲柄左旋螺钉9/64-40 L=4.8	1
39	GK240	挑线杆护罩	1
40	GS0551	挑线杆护罩螺钉3/16-28 L=6	1

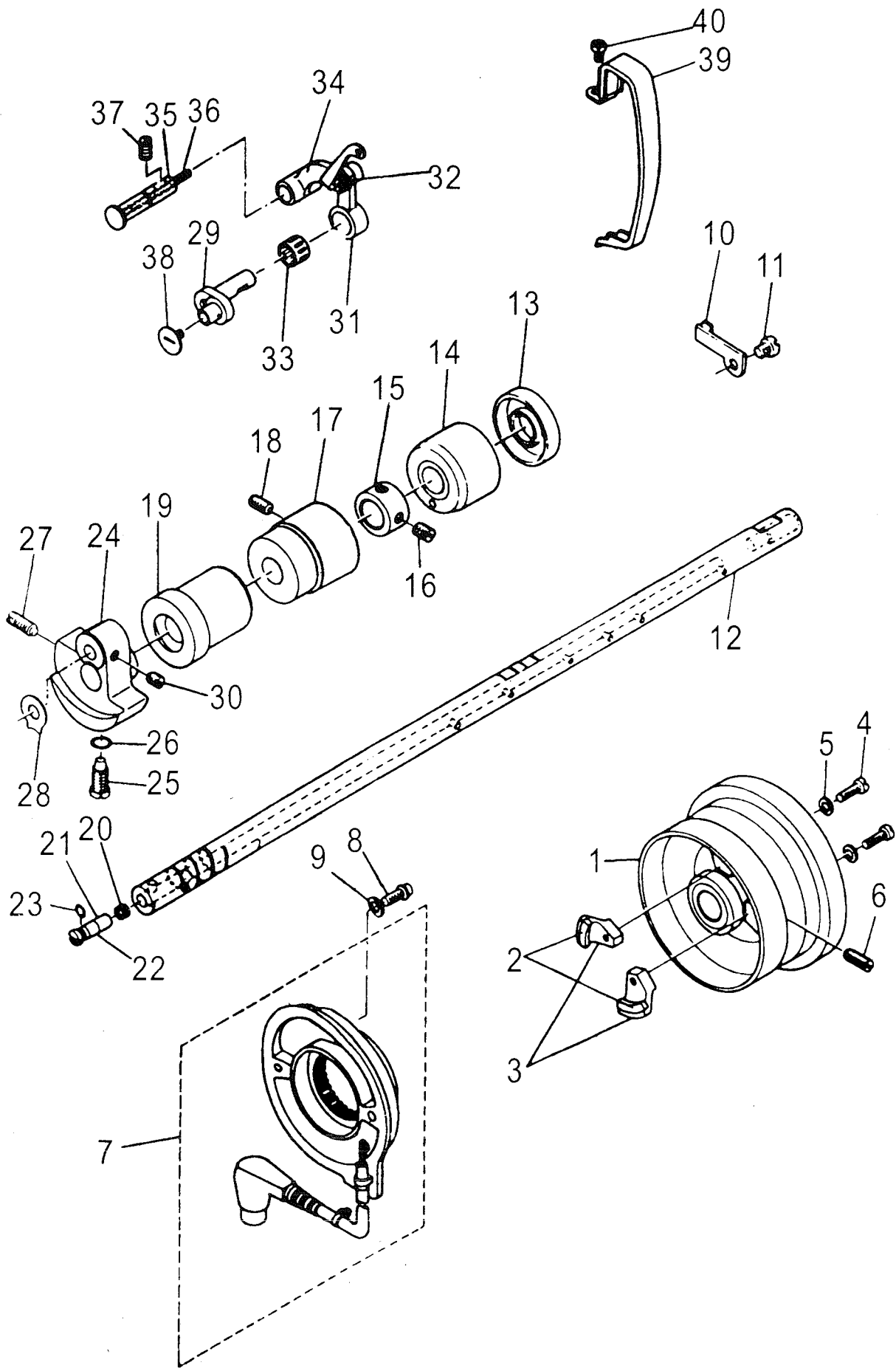

3、针杆、夹线分组件

3.Needle bar & thread tension components

序号	件号	名 称	Description	数量
Ref.No.	Part No.			Amt.
1	GH334	针杆连杆	Needle bar carnk rod	1
2	GO270	针杆连杆滚针轴承	Needle bearing	1
3	GR1478	针杆连接柱	Needle bar connection asm	1
4	GS011	针杆连接柱螺钉9/64-40 L=6	Screw 9/64-40 L=6	1
5	GU168	针杆连接柱滑块	Slide block	1
6	GO271	针杆上衬套	Needle bar bushing, upper	1
7	GR1479	针杆上衬套孔塞	Cap	1
8	GO272	针杆下衬套	Needle bar bushing, Lower	1
9	GR3351	针杆下衬套线勾	Needle bar thread guide	1
10	GZ342/2	针杆部件	Needle bar asm.	1
11	GR2403	针杆线钩	Needle bar thread guide	1
12	GS071	支针螺钉1/8-44 L=4.5	Screw 1/8-44 L=4.5	1
13	GV15	机针(DB×1 14 [#])	Needle (Db×1 14 [#])	1
14	GS5053	上夹线螺钉	First tension post	1
15	GR2413	上过线板	Thread tension guide	1
16	GR1659	上夹线板	Bobbin winder tension disc	2
17	GW332	上夹线簧	Thread ension spring	1
18	GL47	上夹线螺母	Thread tension nut	1
19	GS0551	上夹线器安装螺钉	Screw	1
20	GR3354	右线钩	Frame thread guide, right	1
21	GS0552	右线钩螺钉11/64-40 L=6	Screw 11/64-40 L=6	1
22	GR3355	左线钩	Frame thread guide, left	1
23	GS0552	左线钩螺钉11/64-40 L=6	Screw 11/64-40 L=6	1
24	GR1635	挑线簧调节座	Tension post socket	1
25	GW250	挑线簧	Take-up spring	1
26	GS015	夹线螺钉	Screw	1
27	GS016	夹线螺钉紧固螺钉9/64-40 L=5.5	Set screw 9/64-40L=5.5	1
28	GX567	松线钉	Thread release pin	1
29	GR1488	夹线板	Tension disc	2
30	GR1489	松线板	Tension disc holder	1
31	GW251	夹线簧	Tension spring	1
32	GR1490	夹线制动板	Tension disc stopper	1
33	GL0133	夹线螺母	Tension nut	1
34	GS48	夹线器螺钉15/64-28 L=7	Screw 15/64-28 L=7	1
35	GX568	松线辅钉	Tension release supporting pin	1
36	GR1717	松线辅钉挡圈	Snap ring	1
37	GR3357	松线辅钉垫片	Washer plate	1
38	GW432	松线辅钉弹簧	Tension release pin spring	1
39	GR1664	过线柱	Needle thread guide pin	(1)

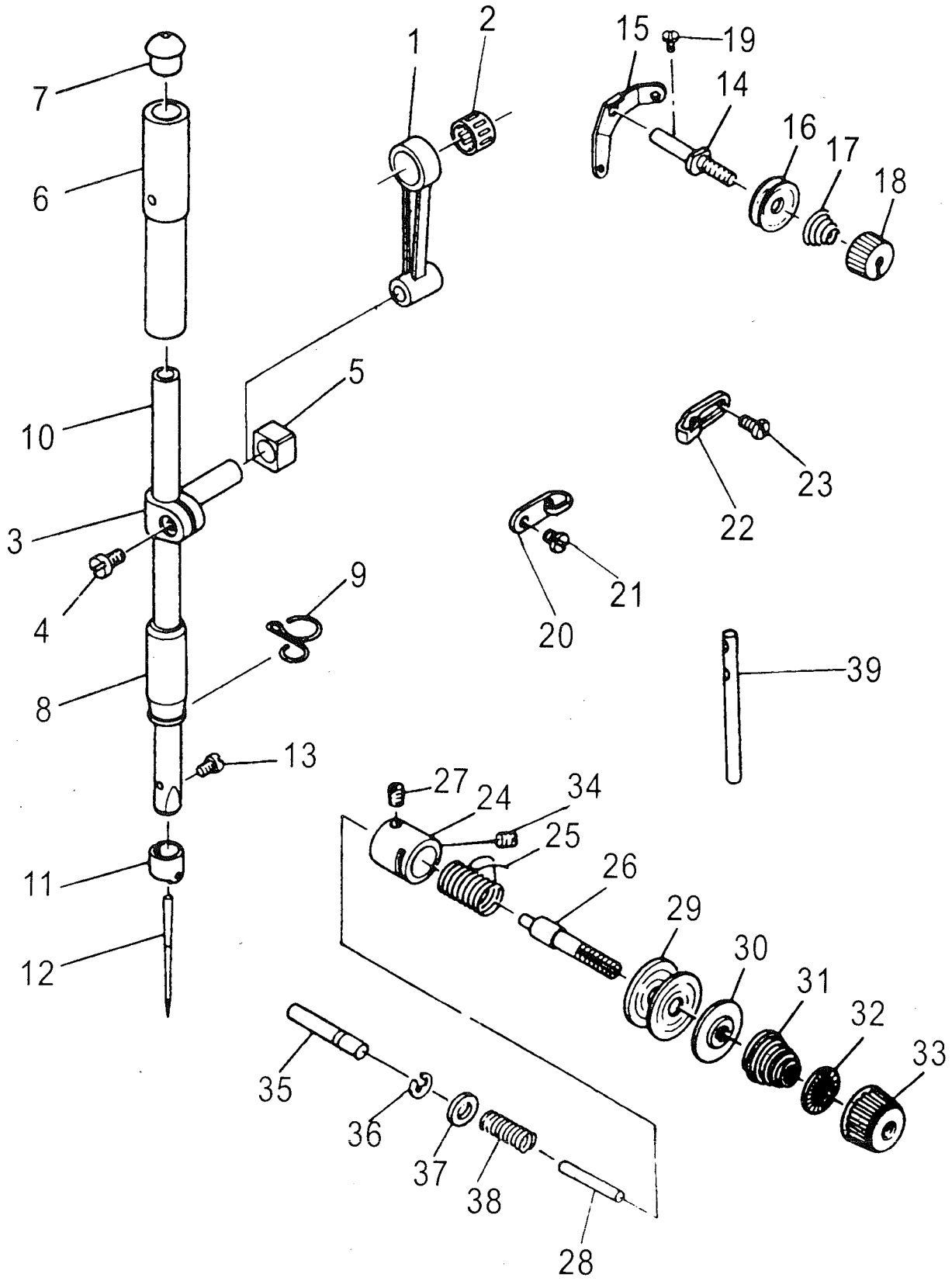

4、压料、松线分组件

4.Presser bar & tension release components

序号	件号	名 称	数量
Ref.No.	Part No.	Description	Amt.
1	GS0553	调压螺钉	1
2	GL0114	调压螺母1/2-28	1
3	GR1494	调压导杆	1
4	GW253	调压簧	1
5	GZ275	压杆	1
6	GR3358	压杆导架	1
7	GS033	压杆导架螺钉1/4-40 L=8	1
8	GR3359	缓线调节钩	1
9	GS0100	缓线调节钩螺钉9/64-40 L=8.5	2
10	GO273	压杆衬套	1
11	GM214/5	活压脚部件	1
12	GS020	活压脚螺钉9/64-40 L=10.5	1
13	GR3360	压脚扳手	1
14	GS0554	压脚扳手螺钉9/64-40 L=9.5	1
15	GR3361/2	压脚扳手凸轮部件	1
16	GR1503	压脚扳手轴O形圈	1
17	GR3363	压脚升降板	1
18	GR3364/3	抬压脚前杠杆部件	1
19	GS0161	前杠杆螺纹销	2
20	GR2035	螺纹销垫圈	2
21	GR1510	螺纹销开口挡圈	3
22	GR3366	升降板连接特制开口挡圈	1
23	GR3367	松线顶板	1
24	GS0162	松线顶板螺纹销	1
25	GR2035	螺纹销垫圈	1
26	GR1510	螺纹销开口挡圈	2
27	GW433	松线顶板复位簧	1
28	GR3368	抬压脚拉杆	1
29	GR1510	拉杆开口挡圈	1
30	GR3369	抬压脚后杠杆	1
31	GS0557	后杠杆轴位螺钉	1
32	GS0558	抬压脚拉杆螺钉	1
33	GR3370	抬压脚顶杆	1
34	GR2416	松线拉丝	1
35	GR2418	松线拉丝软管	1
36	GS078	松线拉丝调节螺钉	1
37	GL19	松线拉丝调节螺母	2
38	GR2419	软管支承板	1
39	GR2420	支承外压板	1
40	GS080	支承外压板螺钉11/64-40 L=7	1
41	GS0551	软管支承板螺钉3/16-28 L=6	1
42	GR2421	软管侧面定位板	1
43	GS0551	定位板螺钉3/16-28 L=6	1
44	GR2422	软管下支承板	1
45	GR2420	下支承外压板	1
46	GS010	下支承外压板螺钉11/64-40 L=5	1

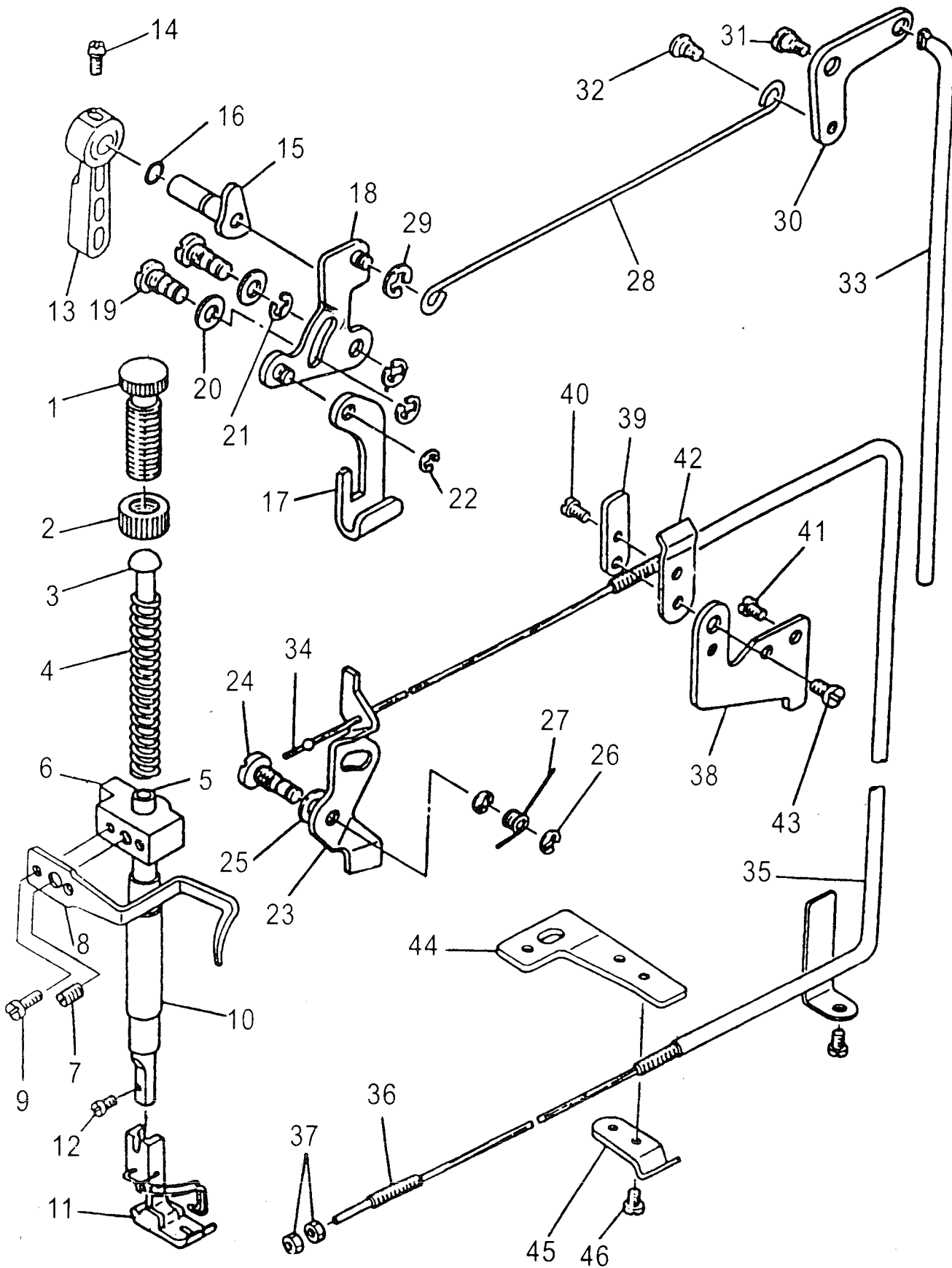

5、勾线分组件

5.Hook driving shaft components

序号	件号	名 称	数量
Ref.No.	Part No.	Description	Amt.
1	GN177	旋梭	Hook asm. 1
2	GN162	梭子	Bobbin case asm. 1
3	GN163	梭心	Bobbin 1
4	GS029	旋梭紧固螺钉	Screw 2
5	GR1685	旋梭定位钩	Positioning finger 1
6	GS030	旋梭定位钩螺钉11/64-40 L=9.5	Screw 11/64-40 L=9.5 1
7	GZ434	下轴	Hook driving shaft 1
8	GS031	下轴限油螺钉	Oil seal screw asm. 1
9	GR1515	下油限油芯	Oil wick 1
10	GR3372	下轴挡油圈	Thrust collar 1
11	GS032	下轴挡油圈螺钉11/64-40 L=3.5	Screw 11/64-40 L=3.5 2
12	GO468	下轴前轴套	Bushing front 1
13	GS0559	下轴前轴套螺钉12/64-28 L=4	Screw 12/64-28 L=4 1
14	GO470	下轴前轴套	Bushing, rear 1
15	GS053	下轴后轴套螺钉12/64-28 L=9	Screw 12/64-28 L=9 1
16	GR1519	下轴挡圈	Thrust collar asm. 1
17	GS082	下轴挡圈螺钉11/64-40 L=4.8	Screw 11/64-40 L=4.8 2
18	GC165	下轴伞齿轮(小)	Pinion asm. 1
19	GS033	伞齿轮螺钉1/4-40 L=8	Screw 1/4-40 L=8 8
20	GC166	竖轴下伞齿轮(大)	Gear asm. large 1
21	GO471	竖轴下轴套	Upright shaft bushing, lower 1
22	GO472	竖轴上轴套	Bushing, upper 1
23	GS053	竖轴上轴套螺钉12/64-28 L=9	Screw 11/64-28 L=9 1
24	GZ435	竖轴	Upright shaft 1
25	GC167	竖轴上伞齿轮(小)	Pinion asm. 1
26	GC168	上轴伞齿轮(大)	Gear asm. 1

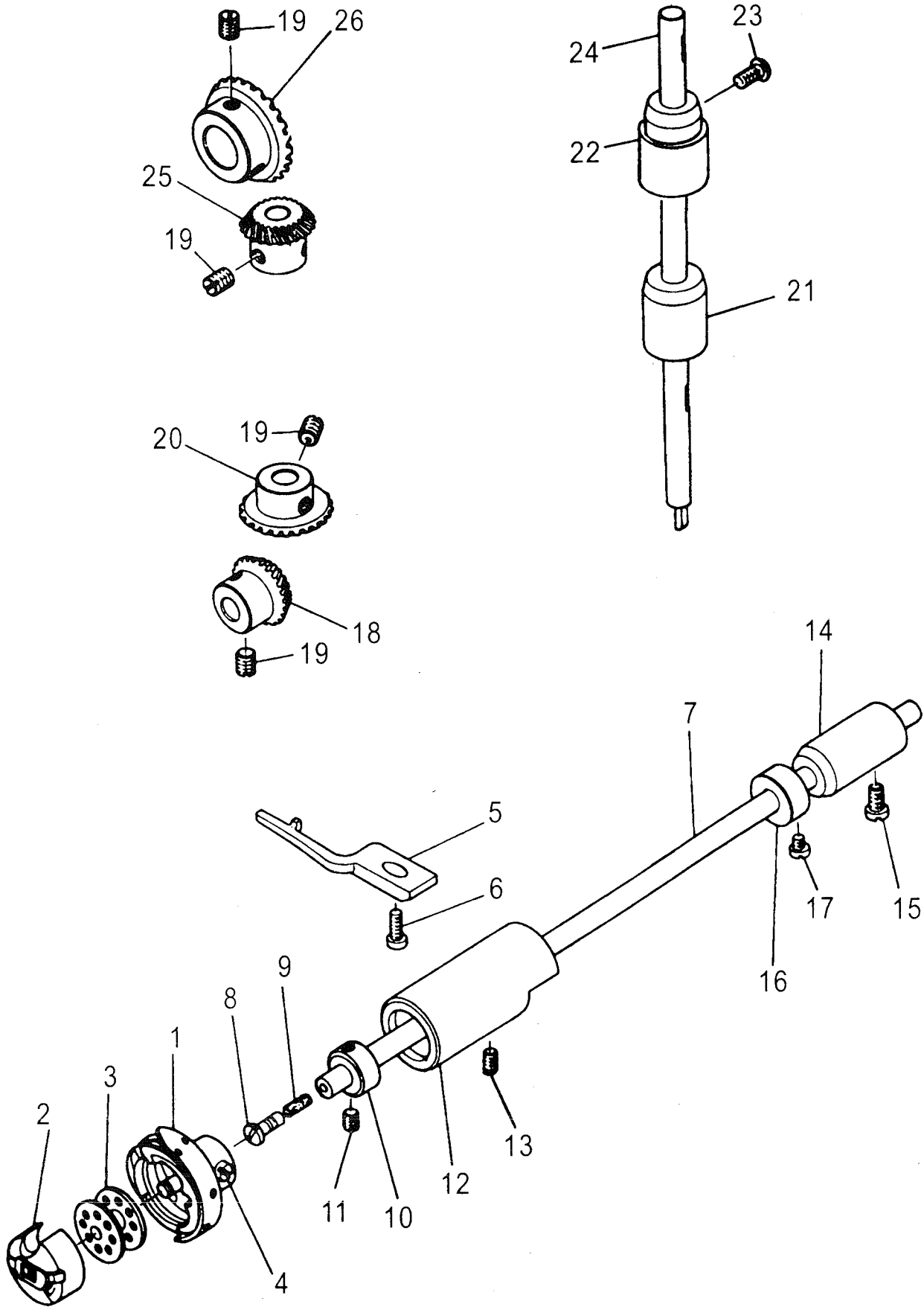

6、送料分组件

6.Feed mechanism components

序号	件号	名称	Description	数量
Ref.No.	Part No.			Amt.
1		送料偏心轮部件	Feed drive eccentric cam asm.	1
2	GT198	送料偏心轮	Feed drive eccentric cam	(1)
3	GS034	送料偏心轮螺钉1/4-40 L=11	Screw 1/4-40 L=11	(2)
4	GR3373	送料偏心轮盖板	Thrust collar	(1)
5	GS011	偏心轮盖板螺钉9/64-40 L=6	Screw 9/64-40 L=6	(2)
6	GH568	送料连杆	Rocker shaft connecting rod	1
7	GX570	送料连杆销	Walking foot pin	1
8	GS0560	送料连杆销螺钉9/64-40 L=6	Screw 9/64-40 L=6	1
9	GR3374	送料长摆动板	Walking foot link	2
10	GR3375	送料短摆动板	Connecting link	2
11	GX571	短摆动板连接销	Walking foot pin	2
12	GS0560	连接销螺钉9/64-40 L=6	Screw 9/64-40 L=6	2
13	GR2423/3	送料摆动板座部件	Walking foot adjust link	1
14	GX573	送料摆动板座左销	Adjusting link fulcrum shaft	1
15	GS48	左销螺钉15/64-28 L=7	Screw 15/64-28 L=7	1
16	GX573	送料摆动板座右销	Adjusting link fulcrum shaft	1
17	GS48	右销螺钉15/64-28 L=7	Screw 15/64-28 L=7	1
18	GH569	送料曲柄	Feed rocker shaft crank asm.	1
19	GX574	送料曲柄销	Walking foot pin	1
20	GS0560	曲柄销螺钉9/64-40 L=6	Screw 9/64-40 L=6	1
21	GS0561	送料曲柄螺钉3/16-28 L=14	Screw 3/16-28 L=14	1
22	GZ436	送料轴	Feed rocker shaft	1
23	GR1524	送料轴轴用挡圈	Retaining ring	1
24	GR1469	送料轴挡圈	Thrust collar asm.	1
25	GS39	送料轴挡圈螺钉1/4-40 L=6	Screw 1/4-40 L=6	2
26	GO473	送料轴前轴套	Feed rocker shaft bushing	1
27	GR3378	送料轴油线	Oil wick	1
28	GR2425	牙架座	Feed rocker asm.	1
29	GS69	牙架座螺钉3/16-28 L=14	Screw 3/16-28 L=14	1
30	GR1528	牙架座螺钉垫圈	Washer	1
31	GR2426/5	牙架部件	Feed bar asm.	1
32	GX418	牙架销	Feed bar shaft	1
33	GS092	牙架销螺钉11/64-40 L=7	Screw 11/64-40 L=7	1
34	GM206	送料牙	Feed dog	1
35	GS072	送料牙螺钉1/8-44 L=6	Screw 1/8-44 L=6	2
36	GM207	针板	Throat plate	1
37	GS044	针板螺钉11/64-40 L=8.5	Screw 11/64-40 L=8.5	2
38	GM340/4	推板部件	Bed slide asm.	1
39	GM204	推板	Slide plate	(1)
40	GW434	推板簧	Bred slide spring	(1)
41	GS045	推板簧螺钉3/32-56 L=1.9	Screw 3/32-56 L=1.9	(2)
42	GH570	抬牙叉形曲柄	Driving shaft crank asm. front	1
43	GS037	抬牙叉形曲柄螺钉11/64-40 L=10.5	Screw 11/64-40 L=10.5	1
44	GZ437	抬牙轴	Feed driving shaft	1
45	GR1524	抬牙轴轴用挡圈	Retaining ring	1
46	GO473	抬牙轴前轴套	Feed rocker shaft bushing	1
47	GH571	抬牙后曲柄	Rear crank asm.	1
48	GS0561	抬牙后曲柄螺钉3/16-28 L=12	Screw 3/16-28 L=12	1
49	GH572	抬牙连杆	Connecting rod	1
50	GS0562	抬牙连杆轴位螺钉	Hinge screw	1
51	GL7	抬牙连杆螺母9/32-28	Nut 9/32-28	1
52	GR1535	抬牙连杆轴用挡圈	Snap ring	1
53	GR1469	抬牙轴挡圈	Thrust collar asm.	1
54	GS39	抬牙轴挡圈螺钉1/4-40 L=6	Screw 1/4-40 L=6	2

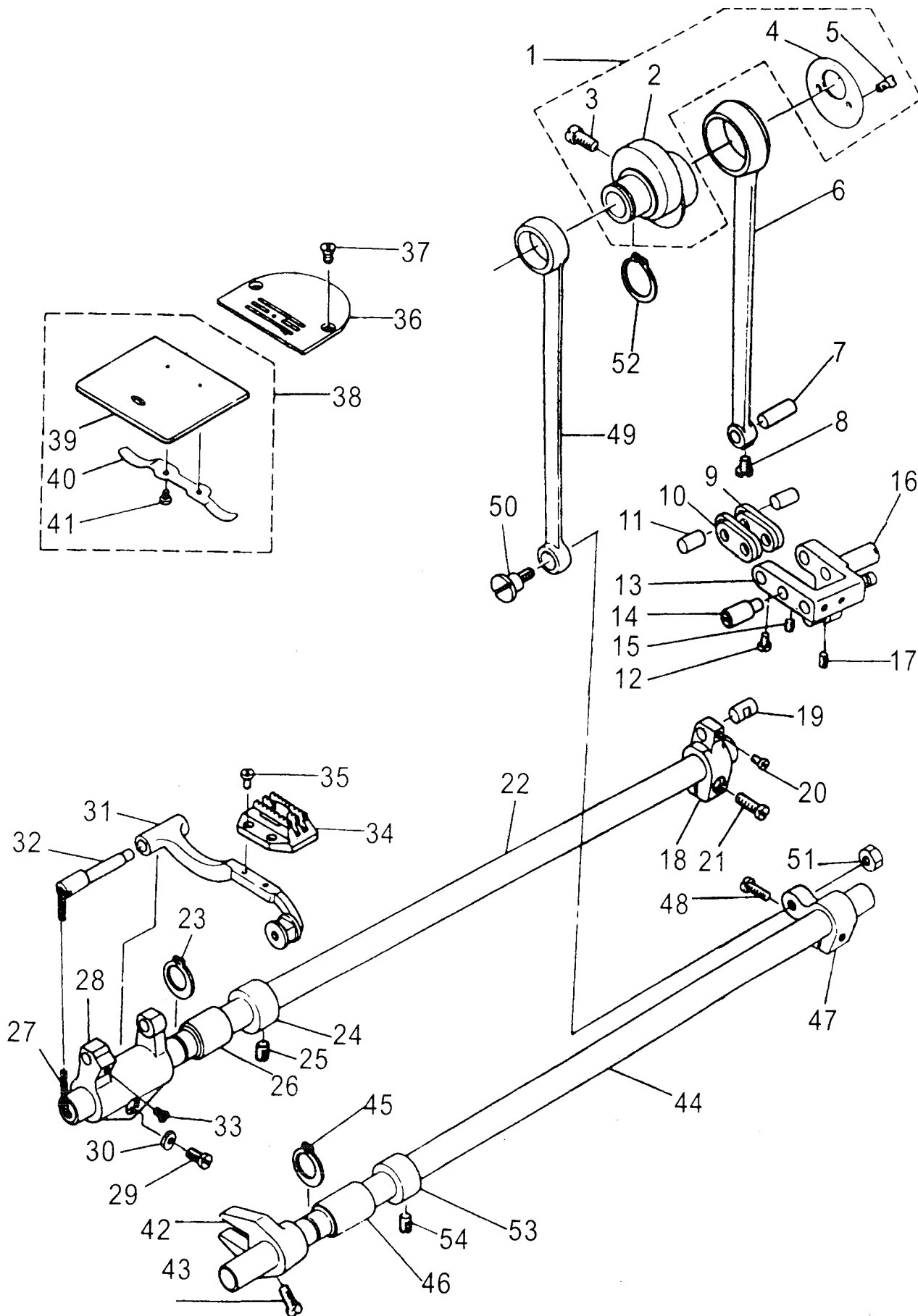

7、送料调节分组件

7.Feed regulating components

序号	件号	名 称	数量
Ref.No.	Part No.	Description	Amt.
1	GR3429	送料距旋钮	1
2	GS0563	送料距旋钮螺钉3/16-28 L=18	1
3	GS0167	送料调节螺柱	1
4	GR3383	送料调节螺柱O形圈	1
5	GX576	送料距锁合销	1
6	GW257	送料距锁合簧	1
7	GR3384	送料调节器	1
8	GO474	送料调节器轴套	1
9	GS0565	送料调节器轴端螺钉	1
10	GX577	倒送料连杆销	1
11	GS011	连杆销螺钉9/64-40 L=6	2
12	GH453	倒送料连杆	1
13	GR1510	倒送料连杆挡圈	2
14	GZ438	倒送料轴	1
15	GR3385	倒送料轴O形圈	1
16	GO475	倒送料轴轴套	1
17	GR3386	倒送料扳手	1
18	GS050	倒送料扳手定位螺钉1/4-40 L=10	1
19	GS033	倒送料扳手螺钉1/4-40 L=8	1
20	GR2428	倒送料扳手挡圈	1
21	GS0222	挡圈螺钉3/16-28 L=18	1
22	GH574/2	倒送料曲柄部件	1
23	GS0566	倒送料曲柄螺钉	1
24	GW435	倒送料拉簧	1
25	GR3387	拉簧固定板	1
26	GR3388	摆动板座复位板	1
27	GS0567	复位板螺钉11/64-40 L=5	2
28	GW436	摆动板座复位簧	1
29	GD305	倒送料电磁铁	1
30	GS0223	安装螺钉15/64-28 L=12	2
31	GX419	铁芯连接销	1
32	GR1717	连接销挡圈	2
33	GR1695	铁芯橡皮垫	1
34	GR2429	铁芯垫	1
35	GR1697	铁芯止动挡圈	1
36	GH454	铁芯连杆	1
37	GH455/3	自动倒送料曲柄部件	1
38	GR1717	曲柄短销挡圈	1
39	GR1510	曲柄长销挡圈	1
40	GR2402	曲柄挡圈	1
41	GR2430	自动倒送料拉杆	1
42	GR1510	拉杆挡圈	1
43	GR2432	开关支承架	1
44	GS053	支承架安装螺钉3/16-28 L=9	2
45	GD306	微动开关	1
46	GR2433	微动开关安装板	1
47	GS571	安装板螺钉M3×16	2
48	GX422	开关安装销	1
49	GW333	安装销复位簧	1
50	GS0224	开关杆定位螺钉	1
51	GR2434/2	开关杆部件	1
52	GR2436	手触倒送料开关罩	1
53	GS81	开关罩安装螺钉11/64-40 L=6	1

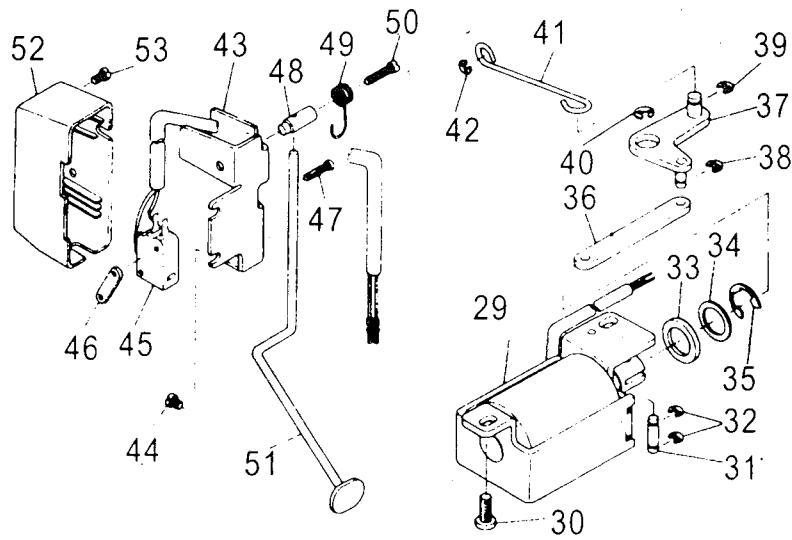
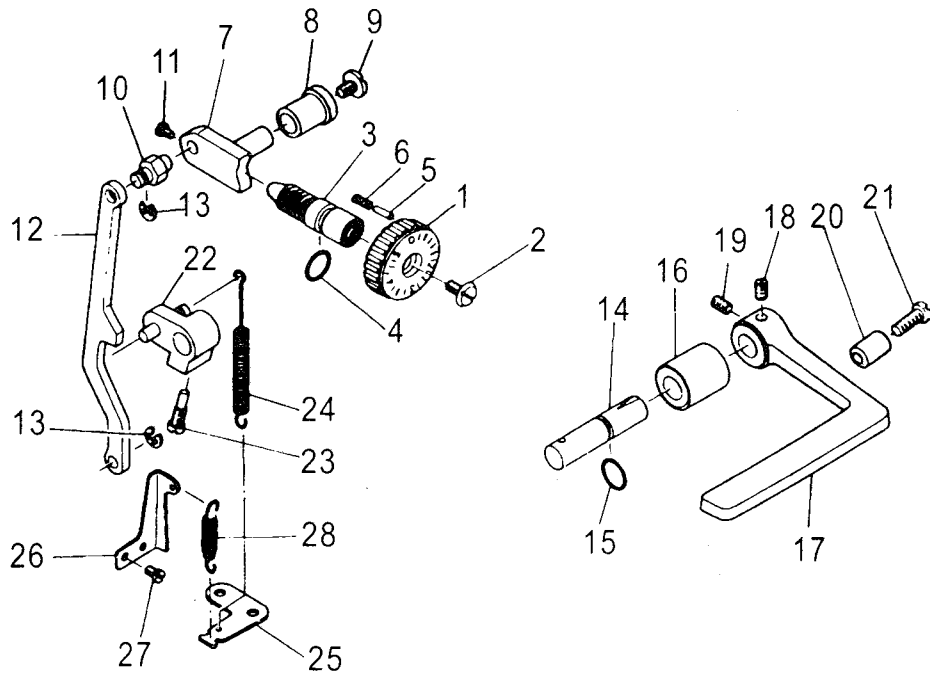

8、剪线分组件

8.Thread trimmer components

序号	件号	名称	数量
Ref.No.	Part No.	Description	Amt.
1	GR2437/11	剪线刀部件	1
2	GH457	动力摆动叉	(1)
3	GS093	摆动叉轴位螺钉	(1)
4	GR2438/2	动刀部件	(1)
5	GS0225	动刀轴位螺钉	(1)
6	GR1705	定刀	(1)
7	GS072	定刀螺钉1/8-44 L=6	(2)
8	GR1706	剪线导线钩	(1)
9	GS095	剪线导线钩螺钉3/32-56 L=2.3	(1)
10	GR2440	剪线刀座	(1)
11	GR1708	定刀安装板	(1)
12	GS81	剪线刀座螺钉11/64-40 L=7	1
13	GR2441/4	挡线器安装座部件	1
14	GR2442/4	挡线器部件	(1)
15	GH458	挡线器座	(1)
16	GS096	挡线器杆螺钉9/64-40 L=5	(2)
17	GT172	剪线凸轮	1
18	GS0226	剪线凸轮螺钉1/4-40 L=6	2
19	GR2444	剪线凸轮挡圈	1
20	GS032	挡圈螺钉11/64-40 L=4.5	1
21	GR2445/3	剪线驱动座部件	1
22	GS062	驱动座安装螺钉15/64-28 L=9	2
23	GR2447/2	驱动曲柄定位板组件	1
24	GS81	定位板螺钉11/64-40 L=7	1
25	GR2450	剪线保护板	1
26	GS81	保护板螺钉11/64-40 L=7	1
27	GW334	剪线驱动曲柄复位簧	1
28	GH459/2	剪线驱动曲柄部件	1
29	GR1507	驱动曲柄定位挡圈	1
30	GR2451	托板支架	1
31	GS0560	托板支架安装螺钉9/64-40 L=6	1
32	GX426	托板支架销	1
33	GW335	托板复位簧	1
34	GR1717	托板支架销挡圈	2
35	GR2452/4	凸轮滚柱托板部件	1
36	GR2456	动力驱动拉杆	1
37	GS0227	摆动叉驱动轴位螺钉	1
38	GX428	拉杆连接销	1
39	GR1599	连接销垫圈	1
40	GL21	连接销螺母	1
41	GR1510	连接销挡圈	1
42	GR2457/2	剪线离合架部件	1
43	GR1507	离合架挡圈	1
44	GW336	离合架复位簧	1
45	GR2460	挡线器拉杆	1
46	GS022	拉杆轴位螺钉	1
47	GX429	挡线器拉杆连接销	1
48	GR2461	挡线器拉杆连接销挡圈	1
49	GR1599	垫圈	1
50	GL21	垫圈螺母	1
51	GR2462	挡油块	1
52	GD307	剪线电磁铁	1
53	GR2463	剪线电磁铁支架	1
54	GR1672	支架连接垫圈	2
55	GL110	支架连接螺母	2
56	GS0223	支架安装螺钉15/64-28 L=12	2
57	GR2464	剪线电磁铁节头	1
58	GS81	节头螺钉11/64-40 L=7	1
59	GR2465	剪线电磁铁拉杆	1
60	GR1510	节头挡圈	1
61	GS0228	拉杆轴位螺钉	1
62	GR3400	电磁铁电线压板	1

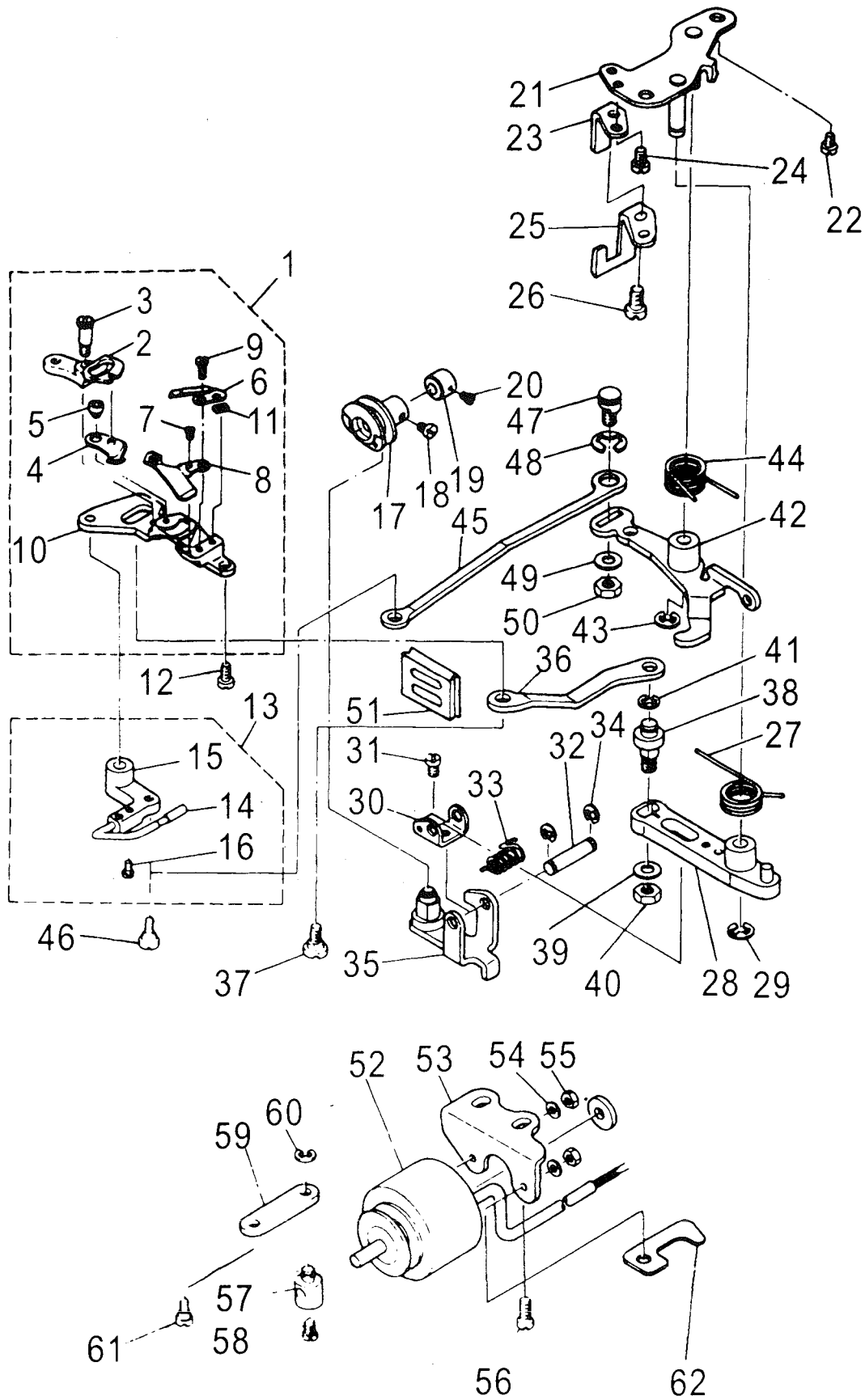

9、拨线分组件

9.Wiper components

序号	件号	名 称	Description	数量
Ref.No.	Part No.			Amt.
1	GR2466/2	拨线电磁铁支架部件	Wiper base asm.	1
2	GS053	支架安装螺钉3/16-28 L=9	Screw 3/16-28 L=9	1
3	GD308	拨线器开关	Power source switch asm	1
4	GD309	拨线电磁铁	Wiper solenoid	1
5	GS304	拨线电磁铁安装螺钉M3×0.5 L=6	Screw M3×0.5 L=6	3
6	GD254	安装螺钉垫圈	Spring washer	3
7	GR2468	铁芯橡皮垫	Wiper rubber	1
8	GR2469	铁芯复位垫	Wiper rubber	1
9	GX430	铁芯传动销	Wiper solenoid pin	1
10	GR2470	传动销定位圈	Thrust collar asm.	1
11	GS0229	定位圈螺钉1/8-44 L=2.5	Screw 1/8-44 L=2.5	2
12	GR2471	传动销滚柱	Wiper link collar	1
13	GR2472	拨线传动板	Wiper link	1
14	GS0230	传动板轴位螺钉	Hinge screw	1
15	GR2473	轴位螺钉定位套	Wiper hinge screw collar	1
16	GL31	轴位螺钉螺母	Nut	1
17	GW337	传动板复位簧	Wiper spring	1
18	GR2474	拨线拉杆	Connecting Link	1
19	GS0231	拉杆轴位螺钉	Wiper link hinge screw	1
20	GL48	拉杆轴位螺钉螺母	Nut	1
21	GZ344/3	拨线驱动轴部件	Wiper driving shaft asm.	1
22	GR1662	驱动轴挡圈	Snap ring	1
23	GR1510	拨线轴挡圈	Snap ring	1
24	GR2475	拨线杆	Wiper	1
25	GS0232	拨线杆紧固螺钉9/64-40 L=5	Screw 9/64-40 L=5	1
26	GR2476	螺钉套圈	Bracket installing collar	1
27	GK203	拨线器罩	Wiper cover	1
28	GS304	拨线器罩螺钉M3×0.5 L=6	Screw M3×0.5 L=6	1
29	GR2477	电线压板	Cord holder	1
30	GR1721	电线夹	Cord holder	1
31	GS053	电线夹螺钉3/16-28 L=9	Screw 3/16-28 L=9	1

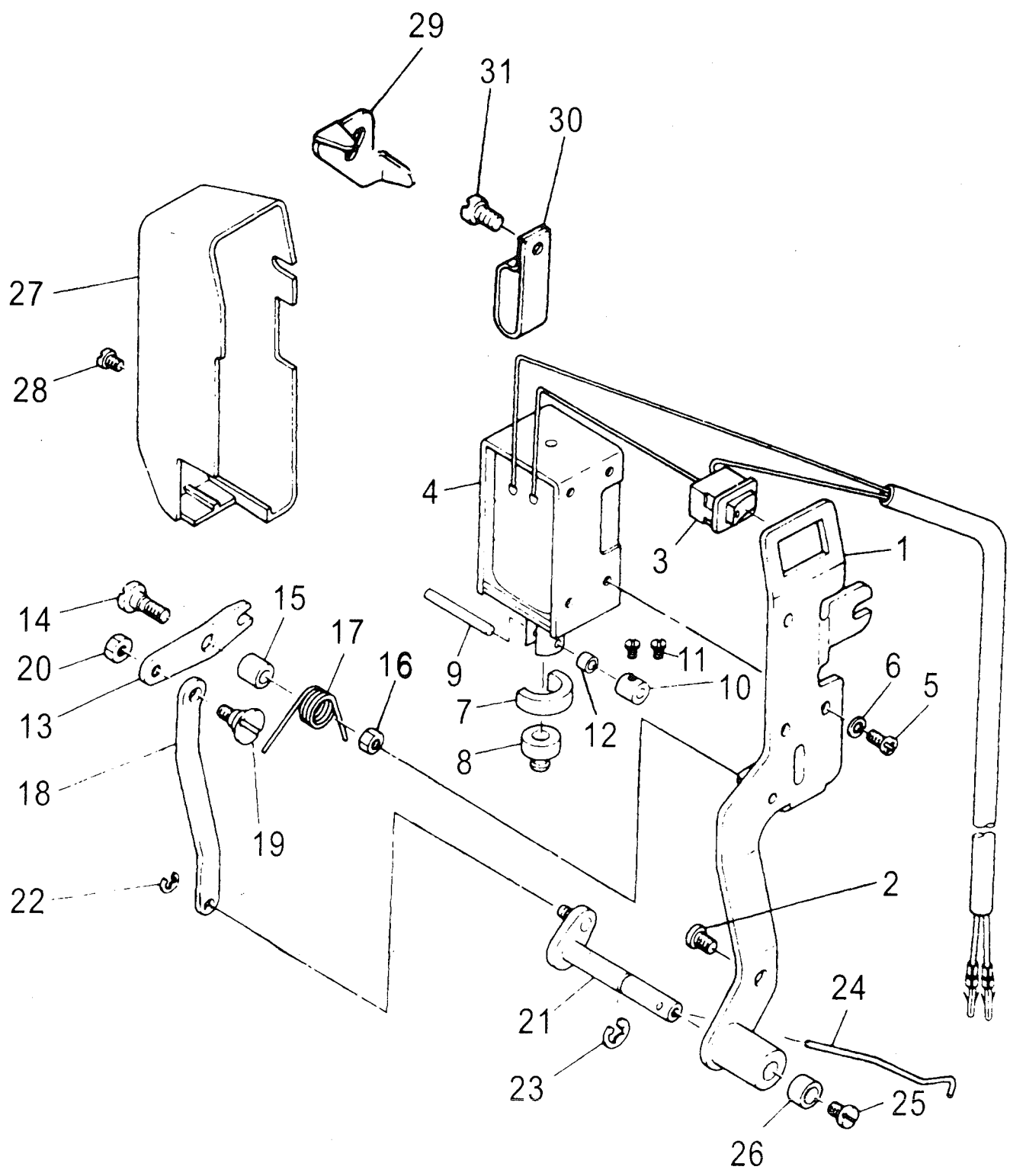

10、润滑分组件

10.Lubrication components

序号	件号	名称	Description	数量
Ref.No.	Part No.			Amt.
1	GR3389/12	油泵部件	Lubricating oil pump asm.	1
2	GR3390	油泵安装板	Oil pump installing base	(1)
3	GS062	油泵螺钉15/64-28 L=8	Screw 15/64-28 L=8	(1)
4	GR3391	油泵体	Oil pump	(1)
5	GO476	油泵体衬套	Oil pmup bushing	(1)
6	GR3392	油泵叶轮	Oil pump impeller	(1)
7	GR3393	油泵叶轮托板	Oil pump impeller cover	(1)
8	GR3394	油泵盖	Lubricating oil pmup cover	(1)
9	GS554	油泵盖螺钉	Screw	(3)
10	GR3395	下轴供油管	Hook driving shaft oil tube	(1)
11	GR3396	回油柱塞	Plunger	(1)
12	GW437	柱塞簧	Plunger spring	(1)
13	GS0569	柱塞螺钉	Plunger screw	(1)
14	GS0568	油泵安装螺钉M3×8 L=7	Screw	(3)
15	GR2478	油泵螺钉垫圈	Washer	1
16	GS0233	油泵连接螺钉	Oil pump support	1
17	GS030	螺柱连接螺钉11/64-40 L=9.5	Screw 11/64-40 L=9.5	1
18	GR3397	供油管接头	Rubber joint	1
19	GR3398	上轴供油管	Main shaft oil tube	1
20	GR3399	旋梭供油管	Oil tube	1
21	GS054	旋梭油量调节螺钉	Oil adjusting screw	1
22	GW259	旋梭油量调节簧	Spring	1
23	GK204	下轴前轴套挡油罩	Oil shield guard	1
24	GR2480	油窗	Oil sight window	1
25	GR1562	油窗O形圈	Rubber ring	1
26	GR3401	回油管	Oil return tube	1
27	GR1566	回油管夹	Oil return tube holder	1
28	GS0551	回油管夹螺钉3/16-28 L=6	Screw 3/16-28 L=6	1
29	GR1567	回油除尘毡	Anti-dust oil felt	1
30	GR1568	回油毡	Oil felt	1
321	GR1569	回油毡夹	Oil felt presser	1
32	GR3403	面部防油板	Arm oil shield	1
33	GR3404	防油板油线	Oil wick	1
34	GS44	防油板螺钉1/8-44 L=4	Screw 1/8-44 L=4	1

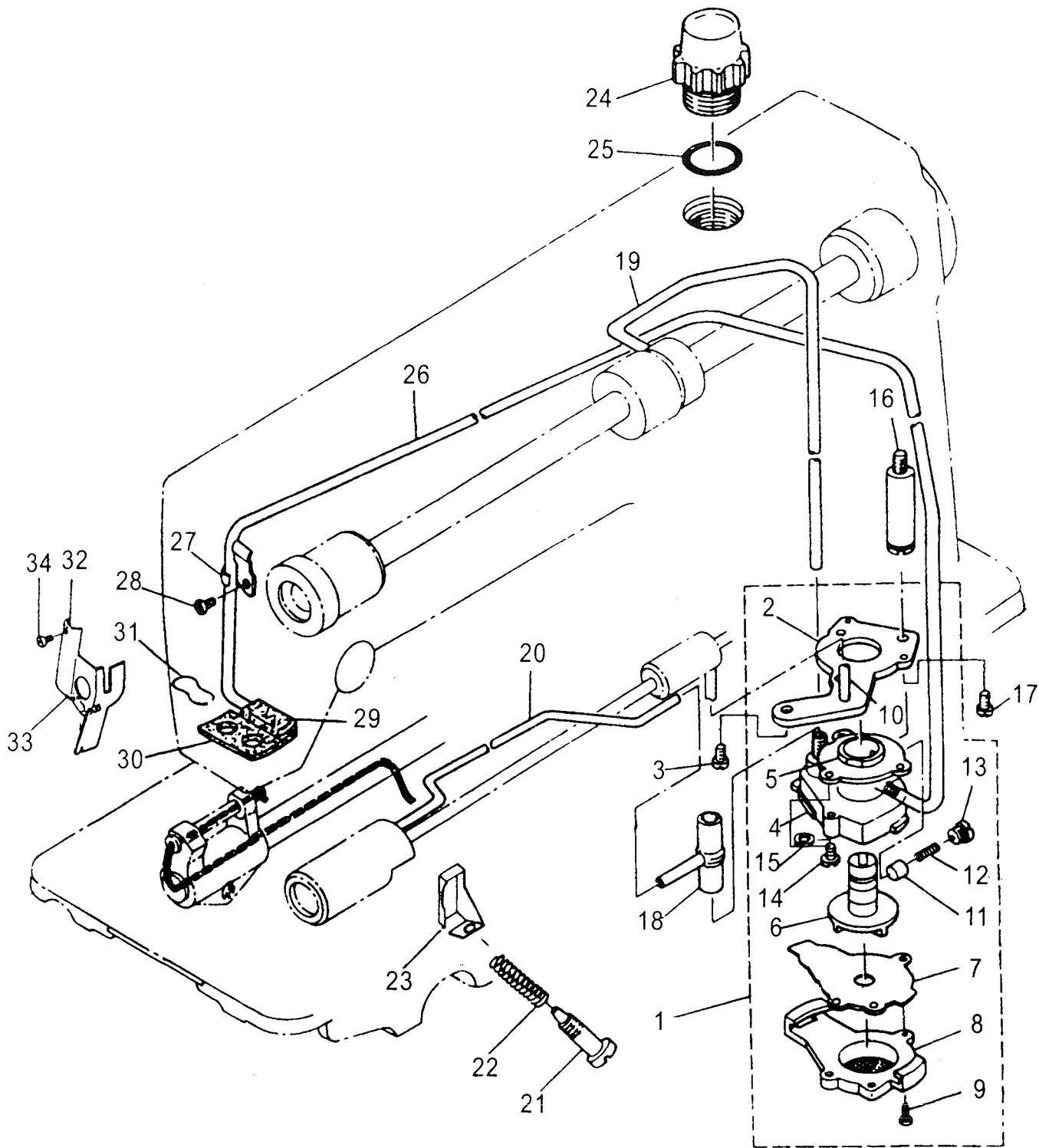

11、油盘、膝抬压脚分组件

11.Oil reservoir & knee lifter components

序号	件号	名 称	Description	数量
Ref.No.	Part No.			Amt.
1	GR3405/17	油盘部件	Oil reservoir asm	1
2	GR3406	油盘	Oil reservoir	(1)
3	GR3407	油盘垫	Gasket	(1)
4	GR3408	机关座垫	Rubber cushion	(4)
5	GS0571	排油孔螺钉	Screw	(2)
6	GR3409	排油孔螺钉O形圈	Rubber ring	(2)
7	GR1576	油盘磁铁	Oil reservoir magnet	1
8	GR1578	油盘座垫	Oil reservoir felt cushion	2
9	GR3956	油盘支座	Oil reservoir rubber cushion	2
10	GBX108	油盘座钉	Nail	4
11	GH579	抬压脚顶销	Knee press lifter rod	1
12	GH576	抬压脚双向曲柄	Connecting rod, vertical	1
13	GS0572	双向曲柄螺钉15/64-28 L=6	Screw 15/64-28 L=6	1
14	GS057	双向曲柄限位调节螺钉15/64-28 L=30	Screw 15/64-28 L=30	2
15	GL21	双向曲柄限位调节螺母15/64-28	Nut 15/64-28	2
16	GW438	双向曲柄扭簧	Spring	1
17	GZ439	抬压脚轴	Knee press rod	1
18	GR1583	抬压脚轴开口挡圈	Snap ring	1
19	GR3410	抬压脚操纵杆节头	Bearing bracket	1
20	GS0573	操纵杆节头螺钉9/32-20 L=20	Screw 9/32-20 L=20	2
21	GR3411/6	操纵杆部件	Knee press plate asm.	1
22	GZ1586	操纵杆	Knee lifter plate rod	1
23	GR3412	操纵板	Knee press plate	1
24	GKR13	操纵板软垫	Knee press plate cover	1
25	GR3413	操纵杆垫	Rubber	1
26	GR3414	操纵杆节头	Knee press plate holder	1
27	GS584	节头螺钉M6×12	Screw M6×12	1

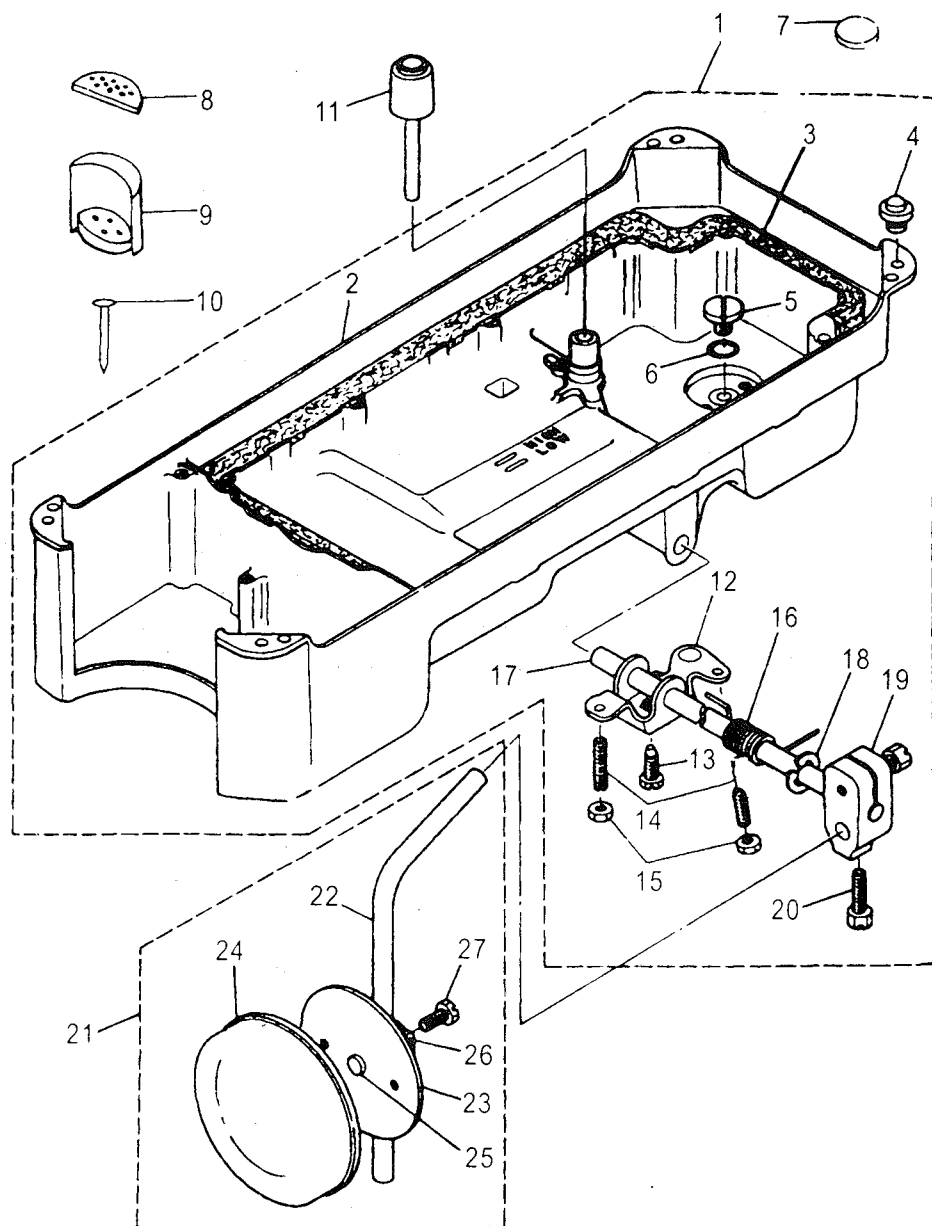

12、机头附件(1)

12.Machine head accessories(1)

序号	件号	名 称	数量
Ref.No.	Part No.	Description	Amt
1	GR1509/2	机头连接钩部件	Machine hinge plate asm. 2
2	GR1593	机头连接钩座	Machine hinge plate 2
3	GBX105	机头连接钩座钉	Nail 4
4	GK241	上轮前罩壳	Beltcover 1
5	GK243	上轮后罩壳	Beltcover 1
6	GK244/2	后罩壳盖部件	Beltcover, B cover asm. 1
7	GBS120	后罩壳安装木螺钉	Wood screw D=4.5 L=20 2
8	GBR147	木螺钉垫圈	Washer 2
9	GB0574	前罩壳紧固螺钉	Beltcover, A screw 2
10	GS0575	后罩壳支柱	Beltcover 1
11	GS0576	支柱螺钉	Screw 3/6-28 L=14 1
12	GR3417	螺钉垫圈	Washer 1
13	DB×1	机针	Needle 2
14	GR1610	螺丝刀(大)	Screw driver, large 1
15	GR1602	螺丝刀(中)	Screw driver, medium 1
16	GR1603	螺丝刀(小)	Screw driver, small 1
17	GR749	内六角扳手	Wrench 1
18	GR544	双头扳手	Double-head wrench 1
19	GN163	梭心	Bobbin 3
20	GF424	机头罩	Machine head cover 1
21	GBR148	机头支柱	Machine rest pin 1
22	GR1604/3	油箱部件	Oil reservoir asm. 1

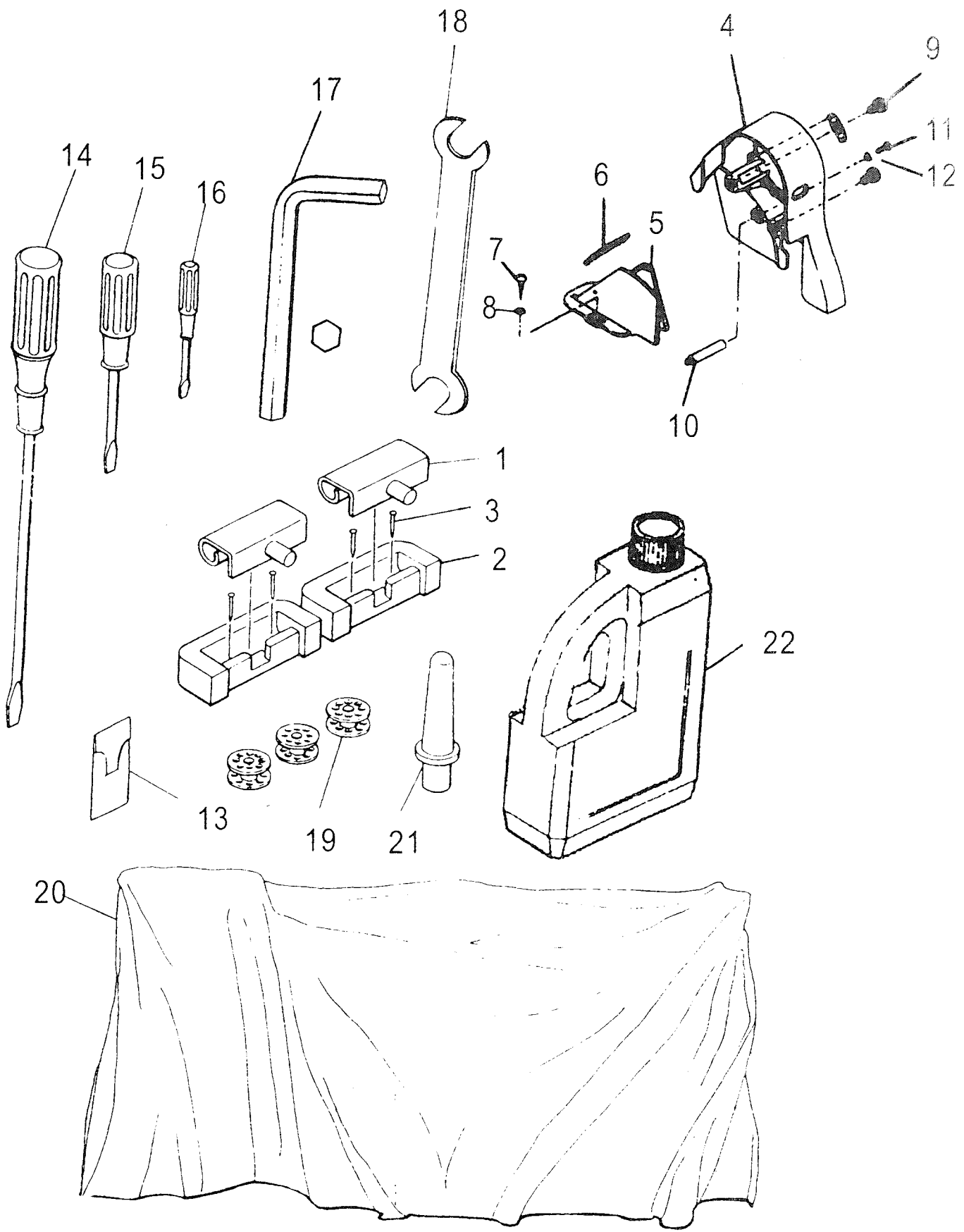

机头附件(2)

7.Feed regulating components

序号	件号	名 称	数量
Ref.No.	Part No.	Description	Amt.
1	GR3419	绕线座	1
2	GR3420	绕线架	1
3	GP167	绕线轮	1
4	GS013	绕线轮螺钉	1
5	GZ284	绕线轴	1
6	GR3421	绕线座连杆	1
7	GX347	绕线座连杆销	1
8	GR3422	绕线架连杆	1
9	GX347	绕线架连杆销	1
10	GS063	绕线架连杆轴位螺钉 1/8-44 L=12.5	1
11	GX348	绕线架销	1
12	GW263	绕线架簧	1
13	GR1613	绕线轮制动垫	1
14	GR3423	制动垫夹	1
15	GS064	制动垫夹螺钉 11/64-40 L=3	1
16	GW439	满线跳板簧	1
17	GS065	满线跳板簧螺钉	1
18	GR3425	过线架座	1
19	GS0577	过线螺钉	1
20	GR1617	过线夹线板挡圈	1
21	GR1488	过线夹线板	2
22	GW265	过线夹线簧	1
23	GL22	过线夹线螺母	1
24	GS0578	过线架紧固螺钉 11/64-40 L=7.8	1
25	GBS120	绕线器木螺钉	2
26	GBR147	绕线器木螺钉垫圈	2
27	GR1744	线架杆顶防护橡皮	1
28	GZ315	线架杆下节	1
29	GZ316	线架杆上节	1
30	GR1932	线架杆接头	1
31	GR1825	线架过线杆	2
32	GR1745	线架过线线夹	2
33	GS558	线架过线夹螺钉	2
34	GR1748	过线圈	2
35	GS0767	线盘钉	2
36	GR1625	线盘钉弹簧垫圈	2
37	GR1626	线盘钉垫圈	2
38	GL23	线盘钉螺母	2
39	GR1811	线盘	2
40	GR4014	线团防松垫	2
41	GR1696	线架杆紧固螺母垫圈	2
42	GR1751	紧固螺母弹簧垫圈	1
43	GL158	线架杆紧固螺母	1
44	GR1753	线架杆防震橡皮圈	2

From the library of: Diamond Needle Corp

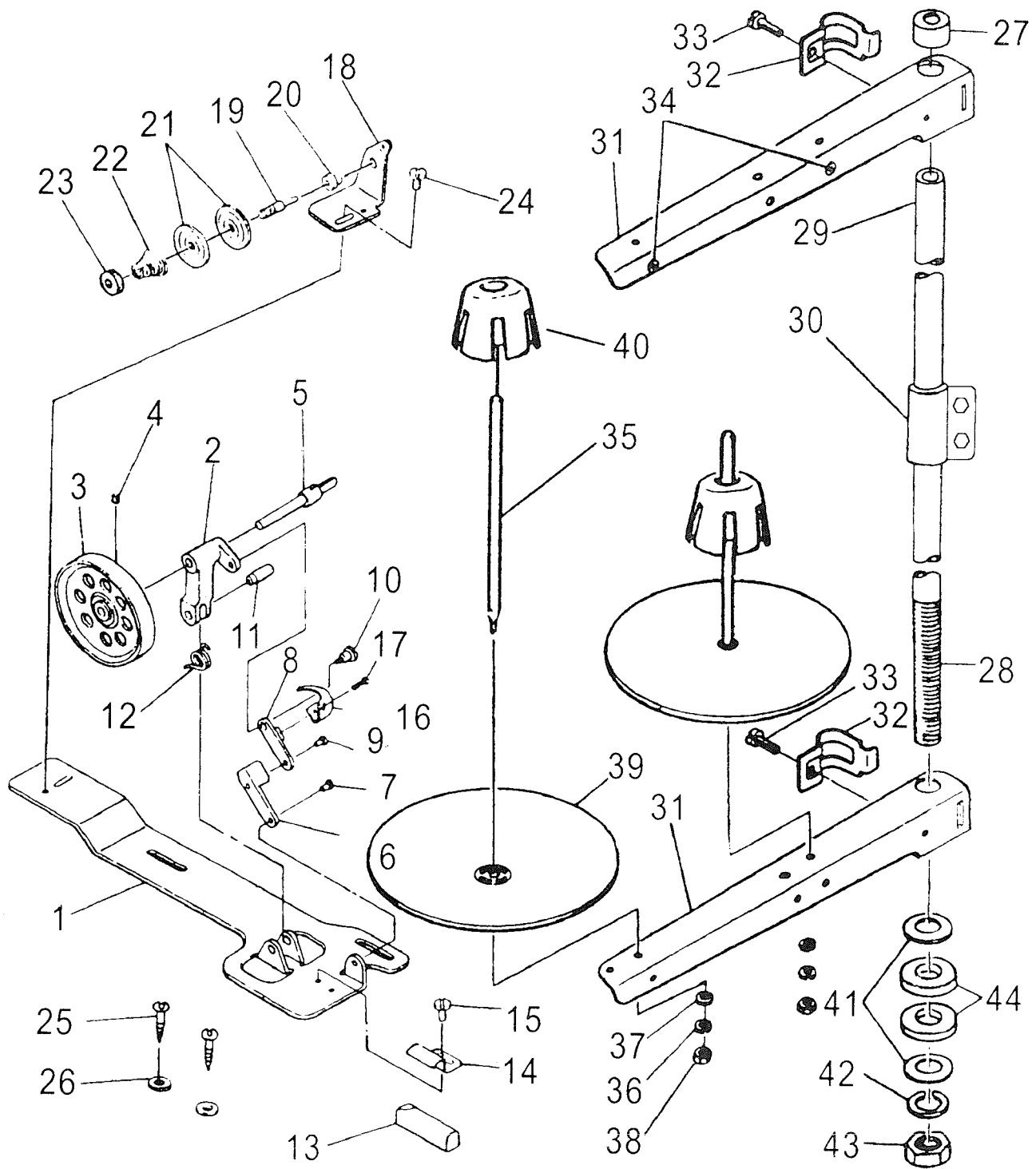

13、机架、台板、电器分组件 13. Machine stand, table & electric appliance components

序号	件号	名称	Description	数量
Ref.No.	Part No.			Amt.
1	GKR302/5	边架部件(左)	Stand side asm. left	1
2	GKR305/5	边架部件(右)	Stand side asm. right	1
3	GKR318	边架座套	Rubber cushion	4
4	GKL104	调节座螺母	Nut	4
5	GKR196/2	调节座	Screw	4
6	GKR198	调节座胶垫	Space ring	4
7	GKR309	横档	Sstand side support asm.	1
8	GKS110	横档连接螺钉	Screw	4
9	GKR106	边架柱弹簧垫圈	Spring washer	4
10	GKR122	边架柱垫圈	Washer	8
11	GKL101	横档固定螺母	Nut	4
12	GKR310	踏板轴档	Treadle brace asm.	1
13	GKS110	踏板轴档螺钉	Screw	2
14	GKR122	踏板轴档垫圈	Washer	2
15	GKR106	踏板轴档弹簧垫圈	Spring washer	2
16	GKR311	踏板轴档定位螺母板	Treadle brace locknut plate	2
17	GKX301	踏板轴	Treadle shaft	1
18	GKR317	踏板轴座	Treadle bracket	2
19	GKS110	踏板轴座螺钉	Screw	2
20	GKR122	踏板轴座垫圈	Washer	4
21	GKR106	踏板轴座弹簧垫圈	Spring washer	2
22	GKL101	踏板轴座螺母	Nut	2
23	GKR312	踏板	Treadle	1
24	GKS313	踏板垫	Gask ket	1
25	GKR314	踏板衬套	Collar	2
26	GKR315	踏板杠杆	Treadle pitman	1
27	GKS102	踏板杠杆螺钉	Screw	2
28	GKR112	踏板杠杆垫圈	Wahser	4
29	GKL102	踏板杠杆螺母	Nut	2
30	GKR183	拉杆接头	Connecting rod joint	1
31	GKS110	拉杆接头螺钉	Screw	1
32	GKL101	拉杆螺钉螺母	Nut	1
33	GZ296	拉杆	Connecting rod	2
34	GR1741	拉杆连接球	Connecting ball joint	2
35	GR1742	连接球支承体	Supporting plate	2
36	GW280	支承体弹簧	Supporting spring	2
37	GKR113	弹簧垫圈	Spring washer	2
38	GL156	连接球螺母	Nut	4
39	GBS114	台板木螺钉	Table wood screw	4
40	GKR112	台板木螺钉垫圈	Table wood screw washer	4
41	GKR186	台板垫	Table washer	4
42	GBR185	台板	Table	1
43	GBR187	抽斗	Drawer	1
44	GBR188	抽斗导轨	Drawer rail	2
45	GBS135	抽斗导轨木螺钉	Drawer rail wood screw	6
46	GBR153	抽斗限位	Drawer limit plate	1
47	GKS122	电机台板连接螺钉	Motor & table connecting screw	3
48	GKR209	电机台板连接垫圈	Motor & table connecting washer	3
49	GKR106	电机台板连接弹簧垫圈	Motor & table connecting spring washer	3
50	GKL101	电机台板连接螺母	Motor & table connecting nut	3
51	GP142	电动机带轮	Motor pulley	1
52	GE123	机头传动带	Machine driving belt	1

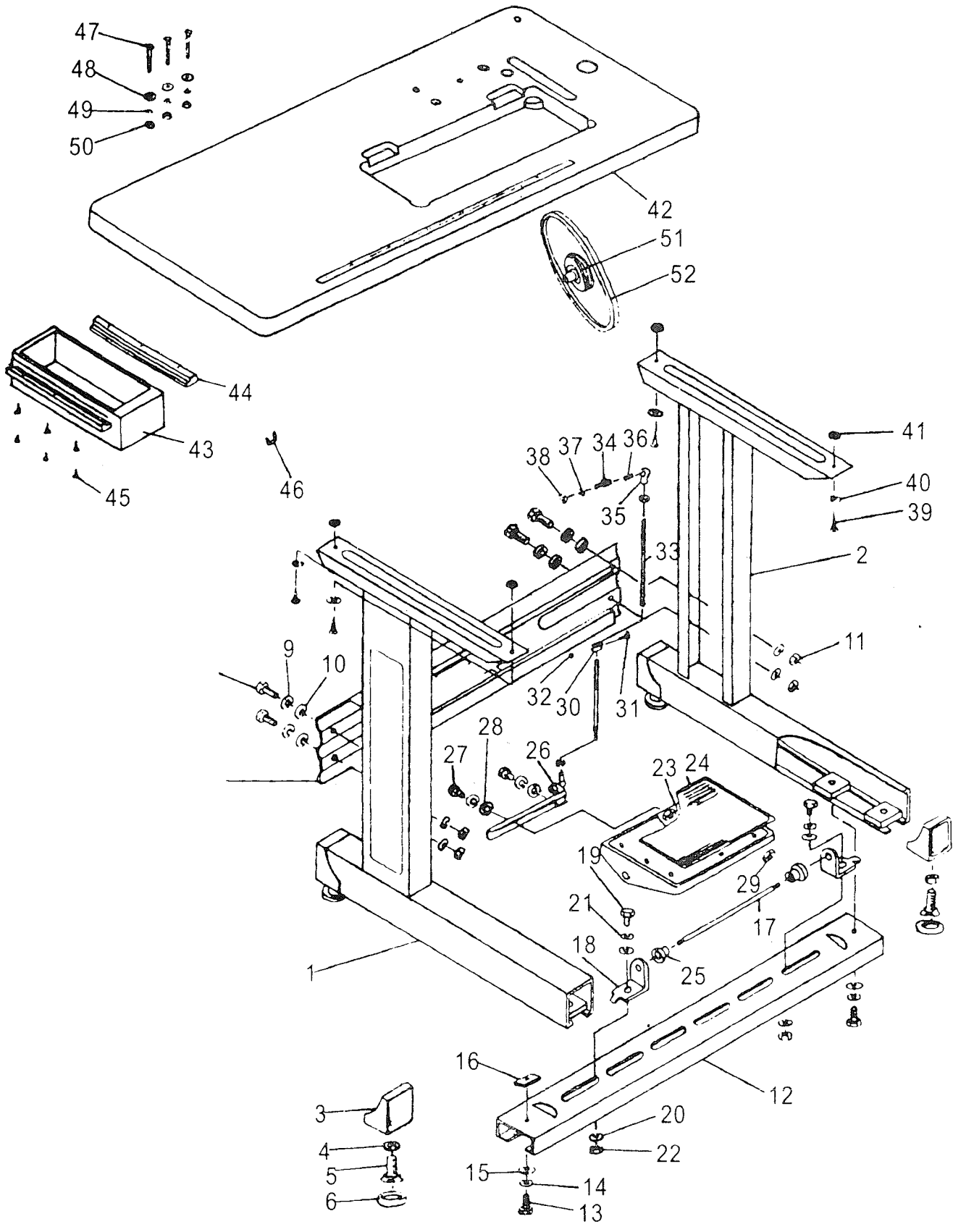

From the library of: Diamond Needle Corp

上 海 惠 工 缝 纫 机 三 厂
SHANGHAI HUIGONG NO.3 SEWING MACHINE FACTORY

地址: 上海市宜山路1418号

ADD: 1418, Yishan Road, Shanghai, China

邮编: 201103

Zip Code: 201103

内销业务: 电话: 86-21-64061284 传真: 86-21-64462799

零件服务: 电话: 86-21-64069792 传真: 86-21-64069792

Overseas Business: TEL: 86-21-64853303 FAX: 86-21-64854304

E-mail: highlead@highlead.com.cn <http://www.highlead.com.cn>

制造商保留因技术改进而更改内容的权利, 恕不另行通知

2005年8月印制