

Purchasing Dept
Copy

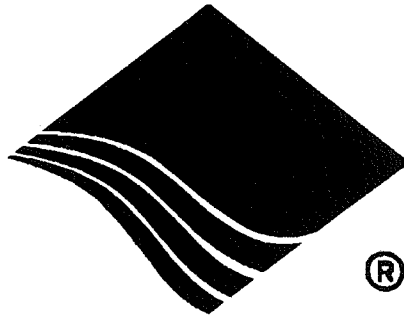

HIGHLEAD

GC0518 SERIES

**HIGH SPEED NEEDLE BAR FEED LOCKSTITCHER
WITH AUTOMATIC THREAD TRIMMER**

**Instruction Manual
Parts Catalog**

From the library of: Diamond Needle Corp

SHANGHAI HUIGONG NO.3 SEWING MACHINE FACTORY

CONTENTS

1. PRECAUTIONS BEFORE STARTING OPERATION.....	2
2. MAIN SPECIFICATIONS.....	2
3. INSTALLING THE BELT.....	3
4. ADJUSTMENT OF NEEDLE BAR STOP POSITION.....	3
5. LUBRICATION.....	4
6. CONDITION OF OIL LUBRICATION.....	4
7. LUBRICATION ADJUSTMENT.....	4
8. ADJUSTMENT OF OIL PUMP.....	4
9. REGULAR CLEANING.....	5
10. WINDING ADJUSTMENT.....	5
11. REPLACE NEEDLES.....	5
12. THREADING.....	6
13. SET STITCH LENGTH AND REVERSE FEEDING.....	6
14. ADJUSTING THE THREAD TENSION.....	6
15. UPPER THREAD TENSION.....	7
16. LOWER THREAD TENSION.....	7
17. ADJUSTMENT OF FEED DOG INCLINATION.....	7
18. ADJUSTMENT OF THREAD TRIMMER MECHANISM.....	8
PARTS CATALOG	
A. ARM BED AND IT'S ACCESSORIES.....	9
B. UP SHAFT MECHANISM.....	12
C. FEEDING NEEDLE MECHANISM.....	15
D. ROTATING HOOK SHAFT MECHANISM.....	17
E. STITCH LENGTH REGULATOR MECHANISM.....	20
F. PRESSER FOOT MECHANISM.....	23
G. KNIFE ACTUATING MECHANISM.....	25
H. WIPER MECHANISM.....	28
I. TOUCH BACK MECHANISM.....	30
J. OIL LUBRICATION MECHANISM.....	33
K. ACCESSORIES.....	35

1. PRECAUTIONS BEFORE STARTING OPERATION

1) Safety Precautions:

- (1) When turning the power on, keep your hands and fingers away from the area around/under the needle and the area around the balance wheel.
- (2) Power must be turned off when the machine is not in use, or when the operator leaves the seat.
- (3) Power must be turned off when tilting the machine head, installing or removing the "V" belt, adjusting the machine, or when replacing.
- (4) Avoid placing fingers, hairs, bars etc., near the balance wheel, "V" belt, bobbin winder balance wheel, or motor when the machine is in operation.
- (5) Do not insert fingers into the thread take-up cover, under/around the needle, or balance wheel when the machine is in operation.
- (6) If a belt cover, finger guard, eye guard are installed, do not operate the machine without these safety devices.

2) Precautions before Starting Operation:

- (1) If the machine's oil pan has an oil sump, never operate the machine before filling it.
- (2) If the machine is lubricated by a drop oiler, never operate the machine before lubricating.
- (3) When a new sewing machine is first turned on, verify the rotational direction of the balance wheel with the power on. (The balance wheel should rotate counter-clockwise when viewed from the balance wheel)
- (4) Verify the voltage and (single or three) phase with those given on the machine nameplate.

3) Precautions for Operating Conditions:

- (1) Avoid using the machine at abnormally high temperature (35°C or higher) or low temperature (5°C or lower) .
- (2) Avoid using the machine in dusty conditions.

2. MAIN SPECIFICATIONS

Item	GC0518	GC0518-H	GC0518-B	GC0518A-D3	GC0518-H-D	GC0518-B-D
Material	Light-Medium heavy		Heavy	Light-Medium heavy		Heavy
Max.sewing speed	5000rpm	3500rpm	3000rpm	5000rpm	3500rpm	3000rpm
Max.Stitch length	4 mm	5 mm	5 mm	4 mm	5 mm	5 mm
Needle bar stroke	31.8 mm	33 mm	35 mm	31.8 mm	33 mm	35 mm
Needle	DB×1#14	DP×5 #18	DP×5 #22	DB×1 #14	DP×5 #18	DP×5 #22
Presser	By hand	5 mm				
	By knee	11 mm				
Touchback mechanism				●		
Lubrication	automatism					
Trimming mechanism				●		
Reversing mechanism				●		
Rotating hook	Auto lubrication hook		Big hook	Auto lubrication hook (Thread trimming)		Big hook
Motor	370W clutch motor			Speed adj. Motor		

3. INSTALLING THE BELT (Fig.1)

- 1) Use a V-belt for sewing machine use, type M
- 2) To adjust the belt tension, change the motor height by turning the tension adjust nuts so that the belt sinks about 15 mm when depressed by hand at the center of the belt span. If the tension is too low, the speed may not be consistent in the low or medium range, or the needle may not stop in the proper position. If the tension is too high, the motor bearings will deteriorate more rapidly.

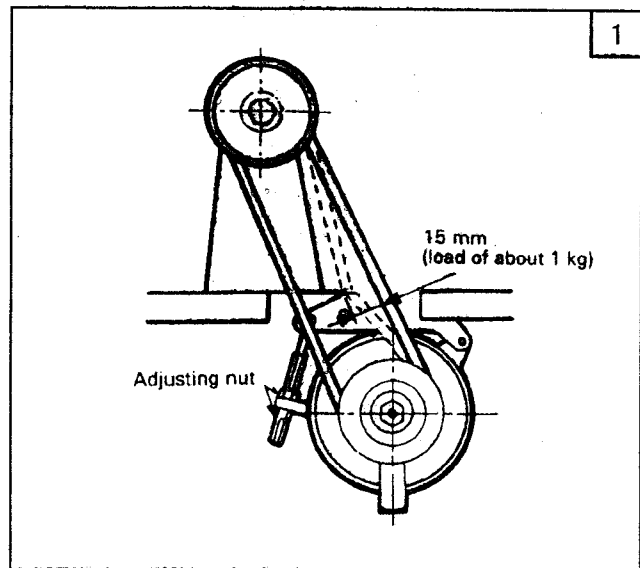

4. ADJUSTMENT OF NEEDLE BAR

STOP POSITION (Fig. 2, 3)

1) Adjusting of "Up" position

When the pedal is kicked down by heel, the machine stops at "UP" position. If the marks deviate larger than 3 mm adjust as follows:

- (1) Disconnect the plug (12 pins) of cable from the machine head.
- (2) Run the machine and stop at "UP" position.
- (3) While holding the balance wheel insert the "adjusting tool" in the hole A, then remove the tool.

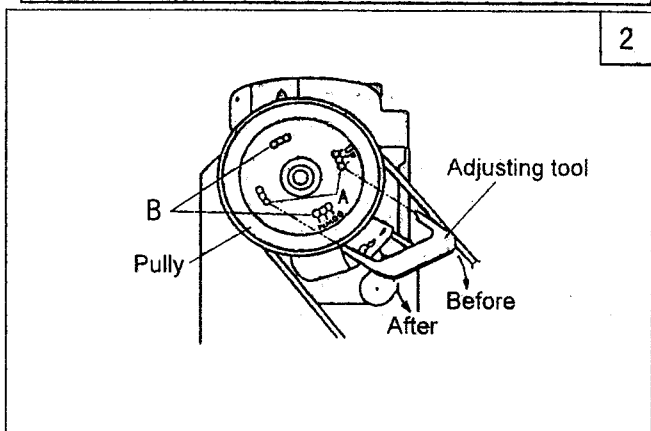

2) Adjusting of "DOWN" position

Set the machine stops at "DOWN" position. When the pedal is kicked down by hell, the machine stops as "DOWN" position. If the marks deviate larger than 3 mm adjust as follows:

- (1) Disconnect the plug (12 pins) of cable from the machine head.
- (2) Run the machine and stop at "DOWN" position.
- (3) While holding the balance wheel insert the "adjusting tool" in the hole B, then remove the tool.

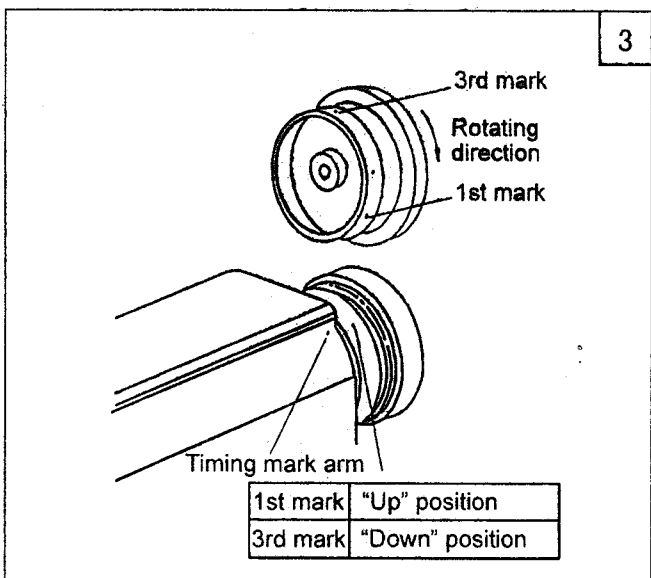

- 3) Confirm the stop operation then the plug (12 pins) coming from the machine head into the receptacle.

5. LUBRICATION (Fig.4)

Pour oil up to position A of the oil tank.

During operation, check the oil level periodically, and in cases where the oil level is below position B replenish the oil supply up to position A.

Use white spindle oil.

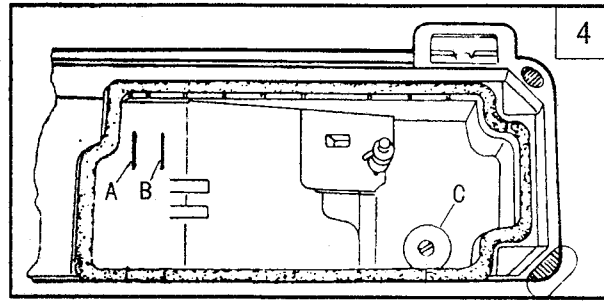

6. CONDITION OF OIL LUBRICATION (Fig.5)

While operating the machine, check the condition of oil lubrication through the oil check window.

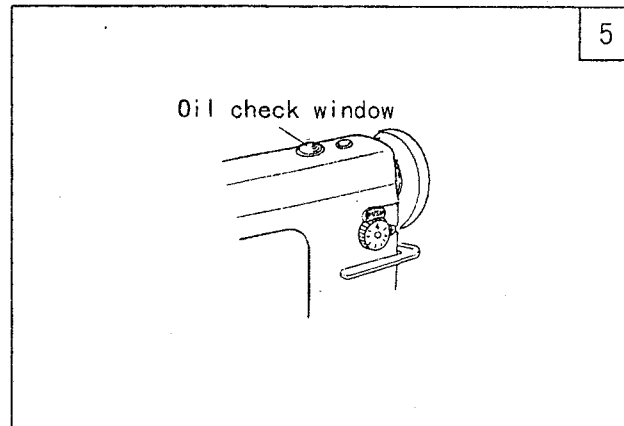

7. LUBRICATION ADJUSTMENT (Fig.6)

Adjusting the lubrication of rotating hook.

Oil adjusting screw (A) can adjust the lubrication of the rotating hook as follows:

(1) Turn oil-adjusting screw (A) clockwise to increase oil and turn oil-adjusting screw (A) counter-clockwise to decrease oil.

(2) Oil adjusting screw (A) adjusts oil amount within 5 turns. When oil-adjusting screw (A) is fully tightened, oil amount is maximum.

(3) Readjustment depends on temperature, sewing speed and the like. In practice, oil amount can be judged as follows: remove the throat plate and place a piece of paper on instead, run the machine for about 20 seconds, then check the oil splashed on the paper.

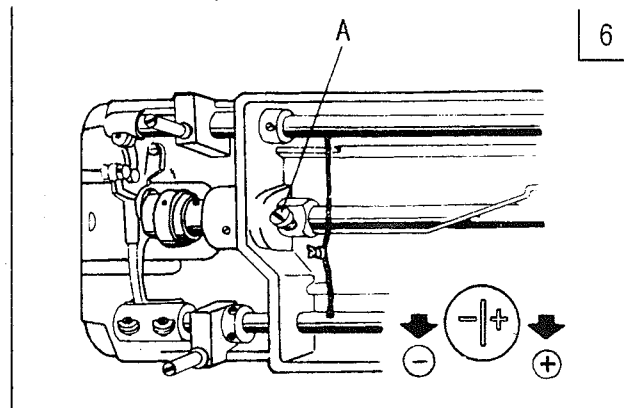

8. ADJUSTMENT OF OIL PUMP (Fig.7)

(Fig.7)

The standard adjustment is as follows: The adjusting plate keeps the bypass hole fully closed. To decrease splashing, open the bypass hole appropriately.

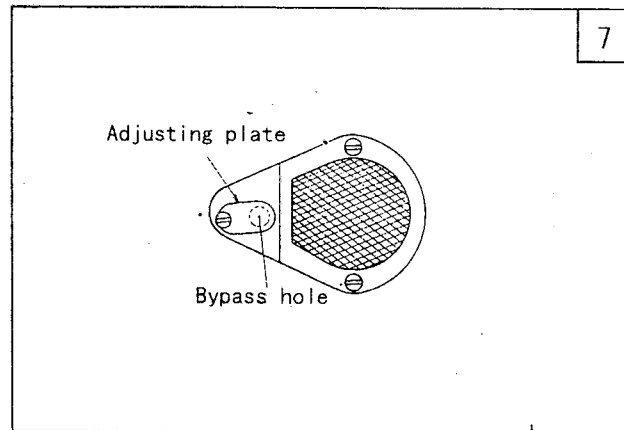

9. REGULAR CLEANING (Fig.8)

1) Cleaning feed dog

Remove the throat plate and clear off the dust and lint between feed dog tooth slots.

2) Cleaning rotating hook

Swing out the machine head and clean the hook. Wipe the bobbin case with soft cloth.

3) Cleaning oil pump, screen

Swing out the machine head and clear off the dust and dirt on oil pump screen.

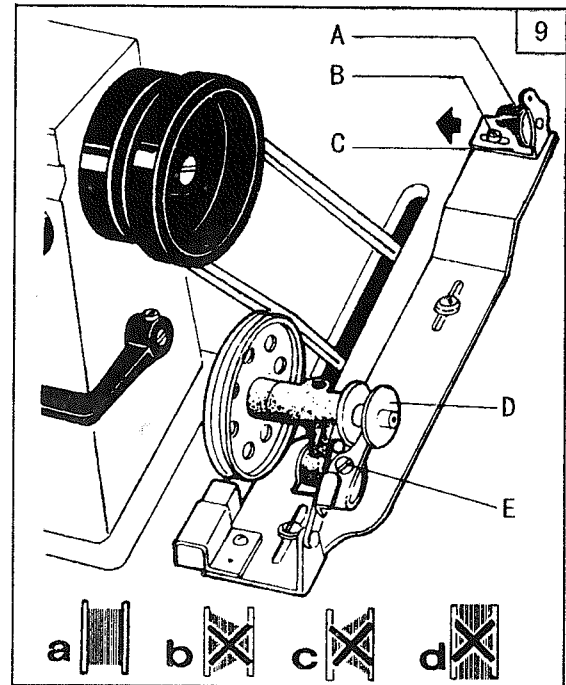
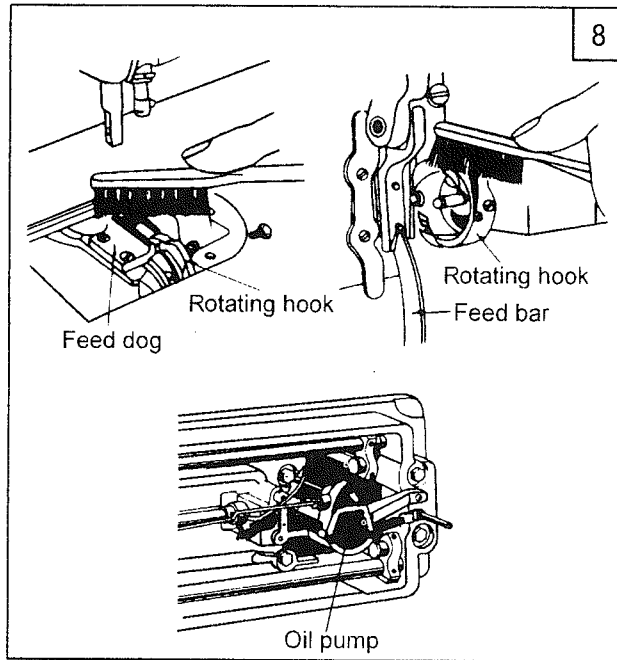

10. WINDING ADJUSTMENT (Fig.9)

1) The wound bobbin thread should be neat and tight, if not, adjust the winding tension by turning tension stud nut (A) of bobbin winder tension bracket.

Note: nylon or polyester thread should be wound with little tension; otherwise, bobbin (D) might break or deform.

2) When the wound thread layer does not present a cylindrical shape as shown in Fig.9 (a), loosen set screw (B) of bobbin winder tension bracket and slide bracket (C) leftward or rightward. If thread is wound as shown in Fig.9 (b), move the bracket rightward, but if thread is wound as shown in Fig.9 (c), move the bracket leftward.

After adequately positioning the bracket, tighten set screw (B).

3) Do not overfill the bobbin. The optimum length of thread will fill about 80% of bobbin capacity. This can be adjusted by adjusting screw (E) of bobbin winder stop latch.

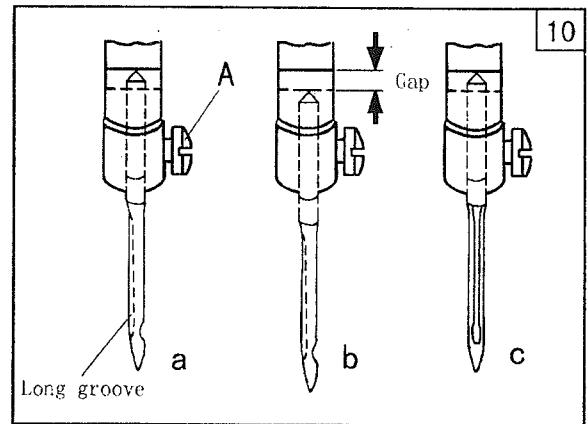

11. REPLACE NEEDLES (Fig.10)

Turn the balance wheel to lift needle bar to the upper end of its stroke. Loosen needle clamp screw (A). While keeping the long groove of the needle leftward fully insert the needle shank up to the bottom of the needle

socket. Then tighten needle clamp screw (A).

Note: Fig. (b): insufficient insertion.

Fig. (c): wrong direction of long groove.

12. THREADING (Fig.11)

To thread the needle thread, raise needle bar to the upper end of its stroke, lead the thread from spool and perform threading as shown in Fig.3. To draw the bobbin thread, hold the end of the needle thread and turn the balance wheel to lower the needle bar and then to lift it to its highest position. Pull the needle thread and the bobbin thread is drawn up. Put the ends of needle thread and bobbin thread forward under presser foot.

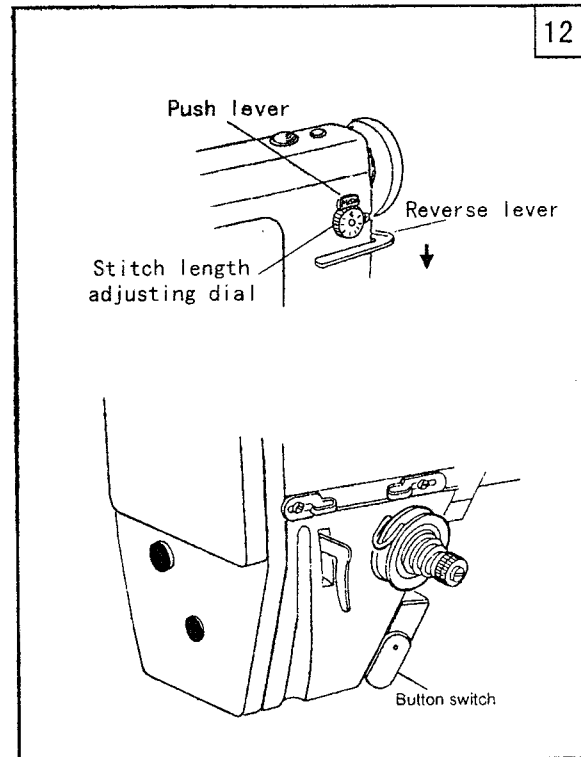
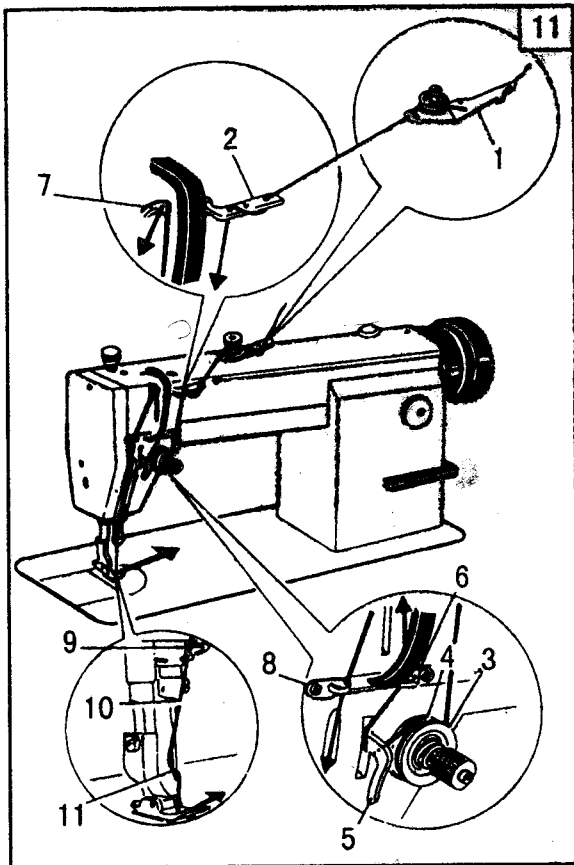

13. SET STITCH LENGTH AND REVERSE FEEDING (Fig.12)

- 1) To change the stitch length, rotate the stitch length adjusting dial while pressing the push lever.
- 2) Pressing the reverse lever to reverse stitching.
- 3) The button switch can be pressed to perform reverse stitching.
- 4) Normally, set the button switch as illustrated by the solid lines. To reverse stitching, press the button switch.

14. ADJUSTING THE THREAD TENSION (Fig.13)

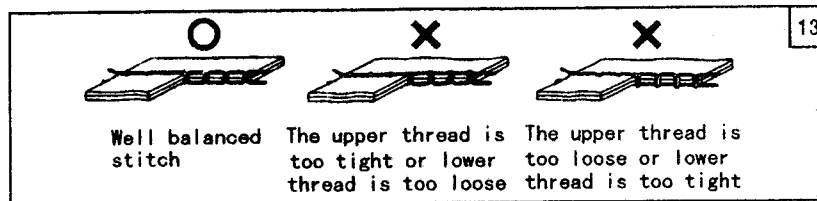

15. UPPER THREAD TENSION (Fig.14)

- 1) The upper thread can be adjusted based on the lower thread tension.
- 2) Adjustment can be done by rotating the thread tension nut. For special fabric sewing with special thread, the desired tension can be obtained by adjusting the strength and operating range of thread take-up spring.

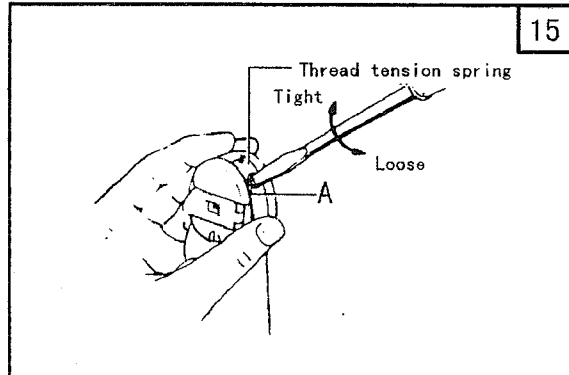
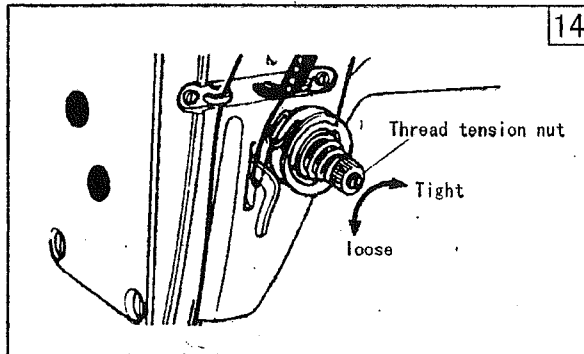

16. LOWER THREAD TENSION

(Fig.15)

- 1) The lower thread tension can be adjusted by rotating screw A.

17. ADJUSTMENT OF FEED DOG

INCLINATION (Fig.16)

The feed dog has been set to standard (horizontally). If necessary, adjust the inclination according to the material to be sewn as follows:

- 1) Slightly loosen screw A located in the feed rock shaft crank.
- 2) Using a screwdriver. While pressing the groove located in the eccentric shaft by using a screwdriver, rotate the eccentric shaft clockwise (to lift the front end) or counter-clockwise (to lower the rear end).
- 3) When adjustment is completed, tighten screw A.

Position of mark on the eccentric shaft	Feed dog
Horizontal	Standard
Up	Front up (MAX.)
Down	Front down (MAX.)

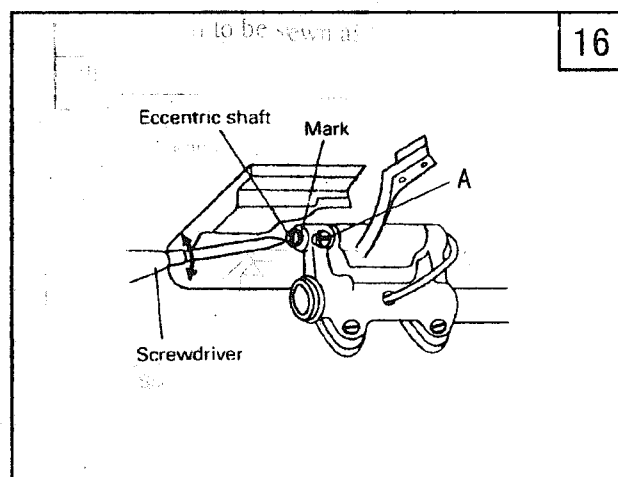

18. ADJUSTMENT OF THREAD

TRIMMER MECHANISM

- 1) Thread trimmer mechanism as shown Fig.17

Operation stroke of the thread trimmer solenoid

- (1) Standard operation stroke is 6.0 mm
- (2) This stroke can be adjusted by using nut A.

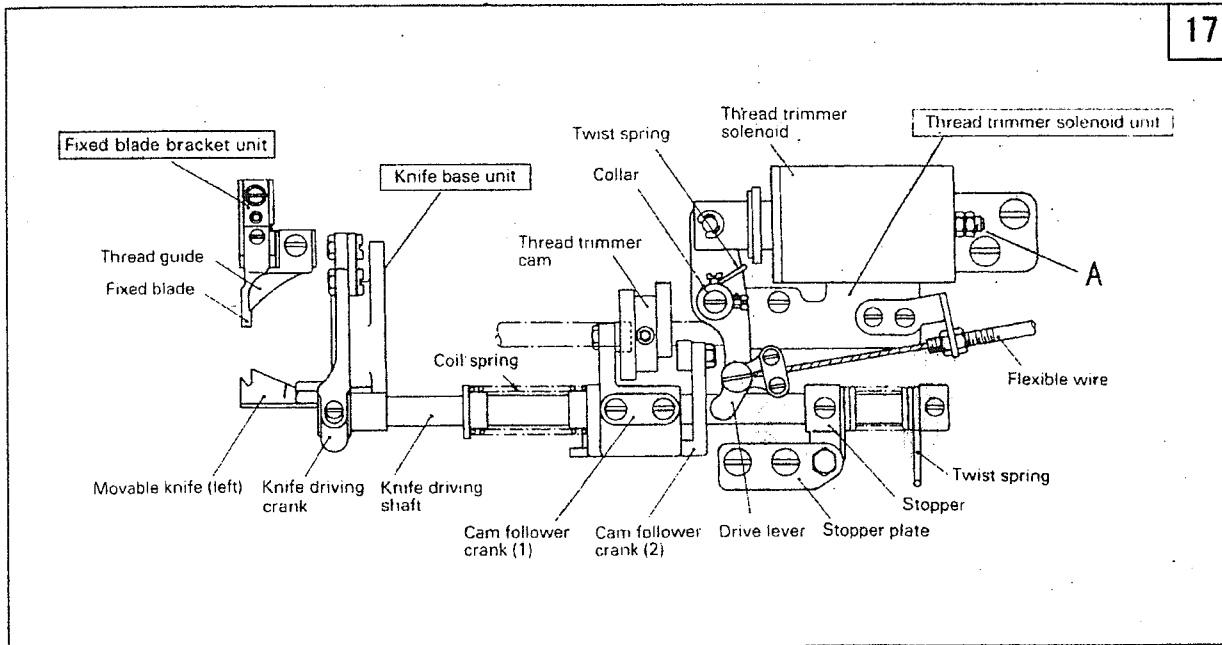

2) Adjustment of knife engagement (Fig. 18)

- (1) Position of movable knife (left) and fixed blade. See the illustration. The standard distances from the needle center are 6.5 mm (B-D/H-D are 7.5mm) and 3.3 mm (B-D/H-D are 5mm) from the movable knife (left) and fixed blade respectively.
- (2) Adjustment of knife engagement. With the solenoid activated, turn on the machine. This rotates the thread trimming cam which rotates the movable knife (left). When the movable knife (left) has moved to its farthest distance, the standard engagement of the blade is 1.5-2.0 mm.
- (3) Adjustment of knife engaging pressure. If a thread is poorly cut, particularly when it is thick, slightly increase the engaging pressure. This should solve the problem. The engaging pressure can be adjusted in this way: Loosen lock nut B, and adjust it by using adjusting screw A.

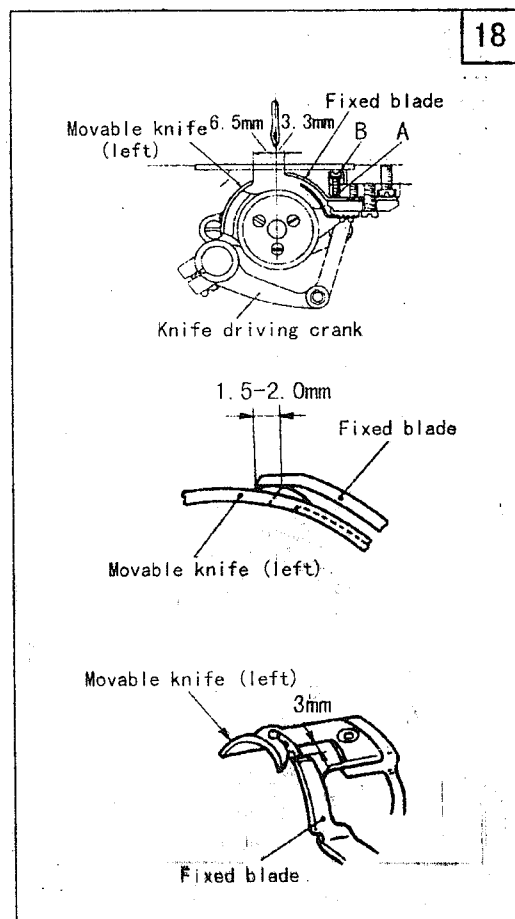

A.ARM BED AND IT'S ACCESSORIES

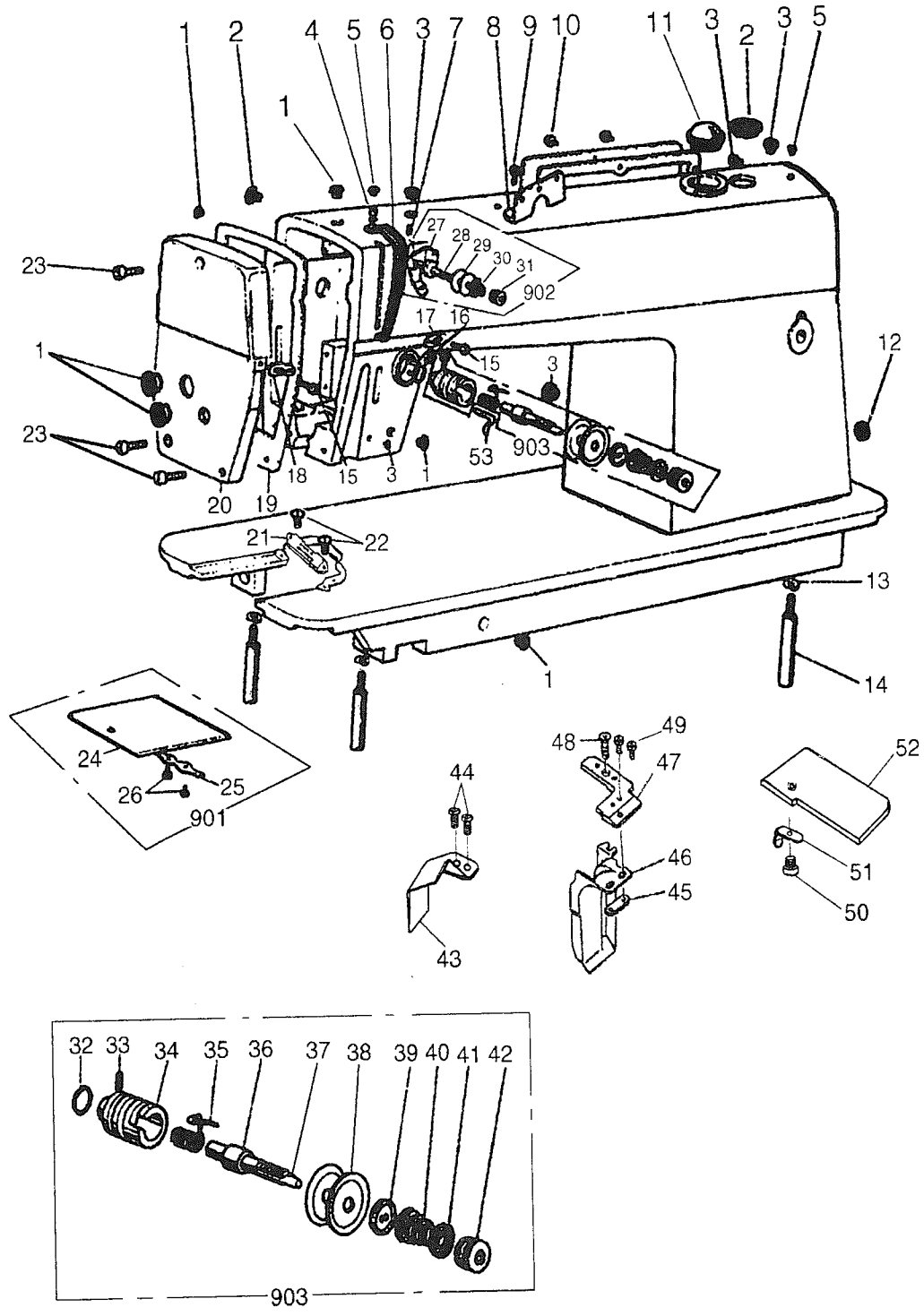

From the library of: Diamond Needle Corp

A.ARM BED AND IT'S ACCESSORIES

Fig. No.	Part No.	Description	GC0518	GC0518A-D3	GC0518-H	GC0518-B	GC0518-H-D	GC0518-B-D	Remarks
A01	HA307B0674	Rubber plug	6	6	6	6	6	6	
A02	HA307B0673	Rubber plug	2	2	2	2	2	2	
A03	HA300B2090	Rubber plug	5	5	5	5	5	5	
A04	HA300C2030	Screw	1	1	1	1	1	1	SM11/64 (40) × 8
A05	HA300B2110	Rubber plug	2	2	2	2	2	2	
A06	HA300C2020	Thread take-up cover	1	1	1	1	1	1	
A07	HA100B2110	Screw	1	1	1	1	1	1	SM11/64 (40) × 5. 5
A08	HA700B2050	Thread guide	1	1	1	1	1	1	
A09	HA700B2060	Screw	1	1	1	1	1	1	SM11/64 (40) × 8
A10	HA300B2170	Screw	6	2	6	2	6	2	SM11/64 (40) × 9
A11	HA309B0069	Oil check window	1		1	1			
A11	H1210B0067	Oil check window		1			1	1	
A12	HA300B2100	Rubber plug	1	1	1	1	1	1	
A13	H005008060	Spring washer	2	2	2	2	2	2	GB/T93 6
A14	HA100B2220	Leg	3	3	3	3	3	3	
A15	HA300B2140	Cloth guide plate	1	1	1	1	1	1	
A16	HA300B2130	Screw	2	2	2	2	2	2	
A17	HA106B0676	Screw	2	2	2	2	2	2	SM9/64 (40) × 6
A18	HA300B2080	Screw	1	1	1	1	1	1	SM15/64 (28) × 6. 8
A19	HA100B2140	Thread guide	1	1	1	1	1	1	
A20	HA106B0675	Thread guide	1	1	1	1	1	1	
A21	H3010B0682	Face plate gasket	1		1	1			
A21	H5729B8001	Face plate gasket		1			1	1	
A22	H3010B0681	Face plate	1		1	1			
A22	H5912B8001	Face plate		1			1	1	
A23	HA300B2160	Screw	3	3	3	3	3	3	SM11/64 (40) × 4. 5
A24	HA300B2190	Screw	2	2	2	2	2	2	SM11/64 (40) × 10
A25	H3000B2120	Needle plate	1	1					
A25	H7704B8001	Needle plate			1	1	1	1	
A26	HA124B0711	Slide plate	1	1	1	1	1	1	
A27	HA124B0712	Plate spring of slide plate	1	1	1	1	1	1	
A28	HA124B0713	Screw	2	2	2	2	2	2	SM3/32 (56) × 2. 2
A29	HA710B0674	Slide plate	1	1	1	1	1	1	
A30	HA710B0673	Pre-tension stud	1	1	1	1	1	1	
A31	HA112B0693	Thread tension disc	2	2	2	2	2	2	
A32	HA710B0672	Pre-tension spring	1	1	1	1	1	1	
A33	HA710B0671	Nut	1	1	1	1	1	1	
A34	HA115B7011	O-ring	1	1	1	1	1	1	
A35	HA115B0708	Screw	1	1	1	1	1	1	SM9/64 (40) × 6
A36	HA310B0703	Thread tension regulator bushing	1	1	1	1	1	1	
A37	HA115B0706	Thread take-up spring	1	1					
A37	HA505B0672	Thread take-up spring			1	1	1	1	
A38	HA115B0701	Thread tension stud	1	1	1	1	1	1	

A.ARM BED AND IT'S ACCESSORIES

Fig. No.	Part No.	Description	GC0518	GC0518A-D3	GC0518-H	GC0518-B	GC0518-H-D	GC0518-B-D	Remarks
A39	HA115B0709	Thread tension releasing pin	1	1	1	1	1	1	
A40	HA310B0705	Thread tension disc	2	2	2	2	2	2	
A41	HA310B0702	Thread tension releasing disc	1	1	1	1	1	1	
A42	HA115B0703	Thread tension spring	1						
A42	H3013B0701	Thread tension spring		1					
A42	HA505B0671	Thread tension spring			1	1	1	1	
A43	HA115B7010	Thumb nut revolution stopper	1	1	1	1	1	1	
A44	HA310B0701	Thumb nut	1	1	1	1	1	1	
A45	H3000B2130	Thread guide	1	1	1	1	1	1	
A46	HA124B0071	Slide plate assy	1	1	1	1	1	1	
A47	HA710B0067	Pre-tension assy	1	1	1	1	1	1	
A48	H3013B0070	Thread tension regulater assy	1	1					
A48	HA505B0067	Thread tension regulater assy			1	1	1	1	

B.UP SHAFT MECHANISM

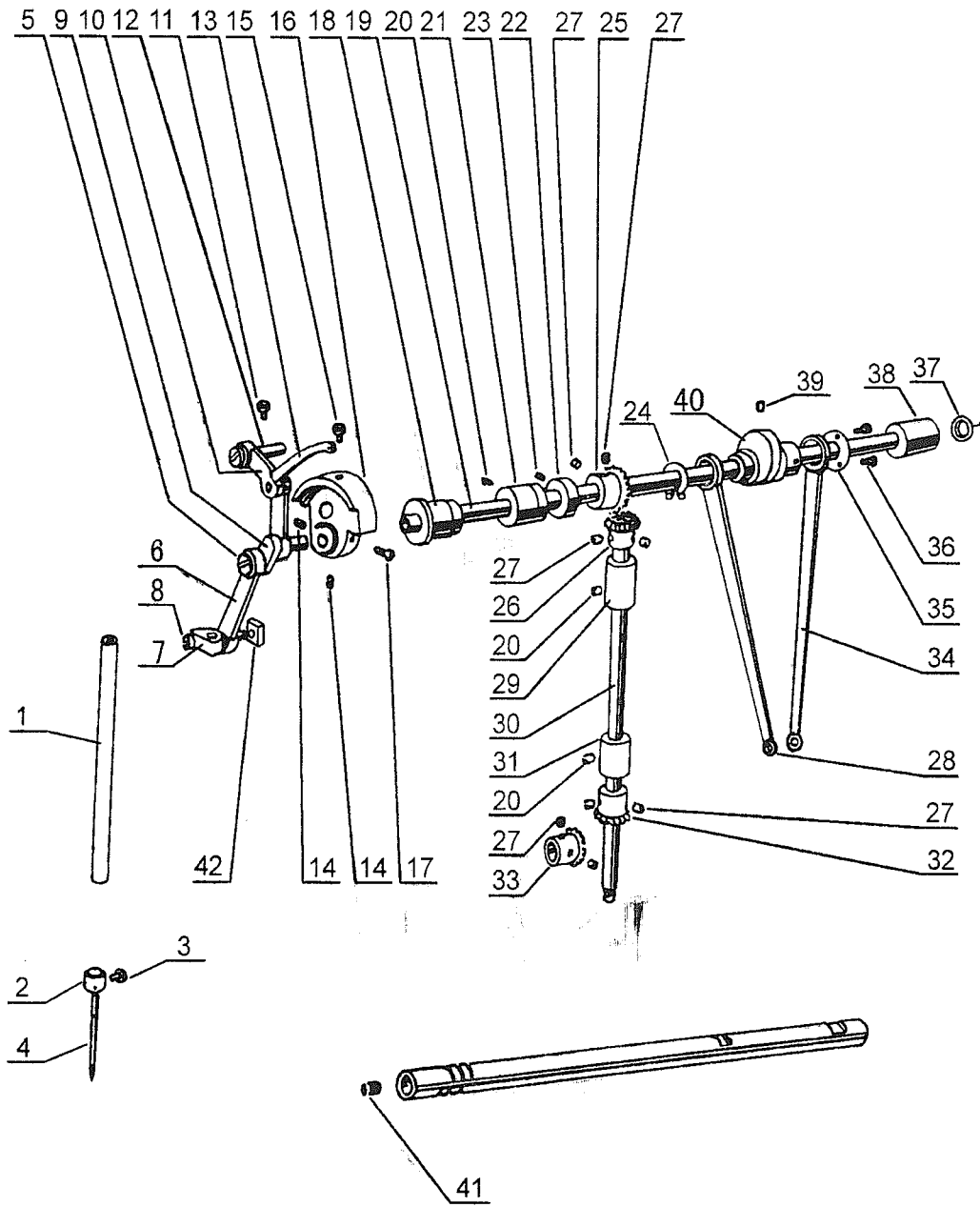

From the library of: Diamond Needle Corp

B.UP SHAFT MECHANISM

Fig. No.	Part No.	Description	GC0518	GC0518A-D3	GC0518-H	GC0518-B	GC0518-H-D	GC0518-B-D	Remarks
B01	HA705G0066	Needle bar	1	1	1	1	1	1	
B02	H3000C2010	Thread guide	1	1	1	1	1	1	
B03	HA100C2170	Set screw	1	1	1	1	1	1	SM1/8(44) × 4.5
B04	HA100C2160	Needle	1	1					
B04	H1000C2010	Needle			1		1		
B04	HA500C2040	Needle				1		1	
B05	HA104C0656	Screw	1	1	1	1	1	1	
B06	HA104C0072	Needle bar link assy	1	1					
B06	HA304C0653	Needle bar link			1	1	1	1	
B07	HA104C0658	Needle bar adaptor	1	1					
B08	H2204C0651	Set screw	1	1	1		1		
B08	HA104C0659	Set screw				1		1	
B09	HA104C0654	Thread take-up crank	1	1	1		1		
B09	HA504C0651	Thread take-up crank				1		1	
B10	HA104C0652	Thread take-up lever link	1	1					
B10	HA304C0012	Thread take-up lever link			1	1	1	1	
B11	HA7311C606	Set screw	1	1	1	1	1	1	
B12	HA104C0653	Hinge pin	1	1	1	1	1	1	
B13	HA1111C104	Thread take-up lever	1	1					
B13	HA3111C104	Thread take-up lever			1		1		
B13	H1111C104	Thread take-up lever				1			
B13	HA604C0011	Thread take-up lever						1	
B14	HA307C0662	Set screw	2	2	2	2	2	2	
B15	HA100C2070	Set screw	1	1	1	1	1	1	
B16	HA108C0661	Needle bar crank	1	1					
B16	HA307C0661	Needle bar crank			1	1	1	1	
B17	HA100C2060	Set screw	1	1	1	1	1	1	
B18	HA100D2030	Arm shaft bushing(left)	1		1	1			
B18	H5904C8001	Arm shaft bushing(left)		1			1	1	
B19	H3005C0065	Arm shaft assy.	1	1	1	1	1	1	
B20	HA100C2020	Set screw	4	4	4	4	4	4	SM15/64(28) × 10
B21	HA100D2040	Arm shaft bushing(middle)	1	1	1	1	1	1	
B22	HA108G0066	Collar for arm shaft assy.	1	1	1	1	1	1	
B23	HA105D0662	Set screw	2	2	2	2	2	2	SM1/4(40) × 4
B24	HA112D3012	Stop ring	1	1	1	1	1	1	
B25	HA113D2112	Bevel gear for arm shaft	1	1	1	1	1	1	
B26	HA113D2122	Bevel gear for vertical shaft(upper)	1	1	1	1	1	1	
B27	HA108C0663	Set screw	8	8	8	8	8	8	SM1/4(40) × 7
B28	HA112D3013	Crank rod for feed rock shaft	1	1	1	1	1	1	
B29	HA100D2110	Vertical shaft bushing(upper)	1	1	1	1	1	1	
B30	HA113D0691	Vertical shaft	1	1	1	1	1	1	
B31	HA100D2110	Vertical shaft bushing(lower)	1	1	1	1	1	1	
B32	HA113D2222	Bevel gear for vertical shaft(lower)	1	1	1	1	1	1	

From the library of: Diamond Needle Corp

B.UP SHAFT MECHANISM

Fig. No.	Part No.	Description	GC0518	GC0518A-D3	GC0518-H	GC0518-B	GC0518-H-D	GC0518-B-D	Remarks
B33	HA113D2212	Bevel gear for hook shaft	1	1	1	1	1	1	SM9/64 (40) × 7
B34	HA7311C506	Crank rod for feed rock shaft	1	1	1	1	1	1	
B35	H30211C406	Washer	1	1	1	1	1	1	
B36	HA7311C306	Set screw	3	3	3	3	3	3	
B37	HA306D0066	Oil seal	1	1	1	1	1	1	
B38	HA300D2020	Arm shaft bushing(right)	1	1	1	1	1	1	
B39	H2000H2020	Set screw	2	2	2		2		
B39	HA100C2020	Set screw				2		2	
B40	H30211C106	Feed and feed lifting eccentric	1	1	1	1	1	1	
B41	HA104D0652	Rubber plug(Φ7.4×10)	2	2	2	2	2	2	
B42	HA100C2200	Slide block	1	1	1	1	1	1	

C.FEEDING NEEDLE MECHANISM

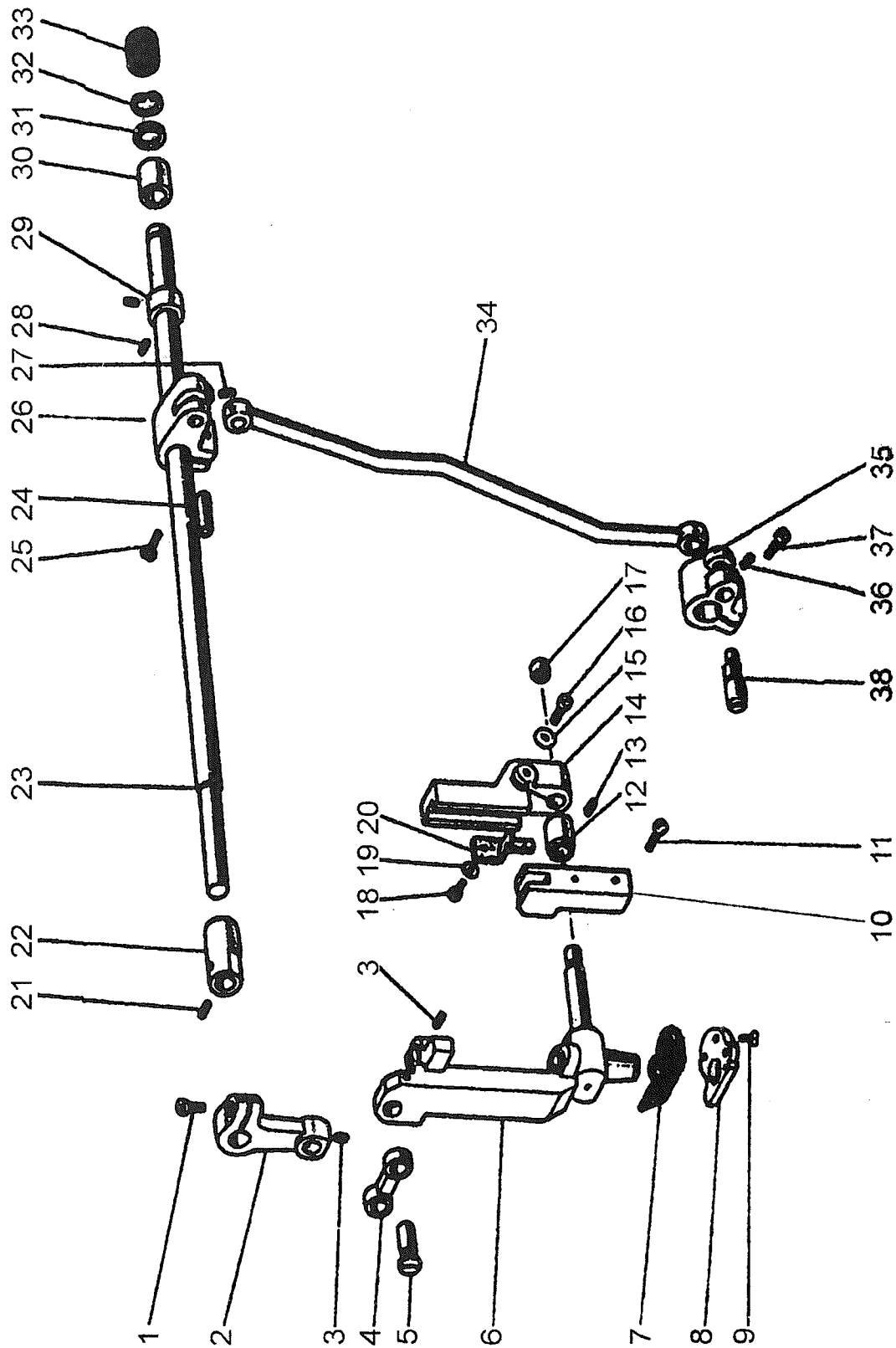

C.FEEDING NEEDLE MECHANISM

Fig. No.	Part No.	Description	GC0518	GC0518A-D3	GC0518-H	GC0518-B	GC0518-H-D	GC0518-B-D	Remarks
C01	HA304G0656	Screw	1	1	1	1	1	1	SM3/16 (28) × 15
C02	H3012D0691	Lever	1	1	1	1	1	1	
C03	HA100B2110	Set screw	2	2	2	2	2	2	SM11/64 (40) × 5.5
C04	H3012D0693	Link	1	1	1	1	1	1	
C05	H3012D0692	Set pin	1	1	1	1	1	1	
C06	H3013D5011	Needle bar supportor assy.	1						
C06	H5904D7101	Needle bar supportor assy.		1					
C06	H7605D7101	Needle bar supportor assy.			1	1			
C06	HD904D7101	Needle bar supportor assy.					1	1	
C07	H3000D2120	Gasket	1	1	1	1	1	1	
C08	H3000D2150	Fitting plate	1	1	1	1	1	1	
C09	H3000D2160	Screw	3	3	3	3	3	3	SM9/64 (40) × 4.5
C10	H3000D2170	Guide bracket	1	1	1	1	1	1	
C11	HA300C2030	Screw	2	2	2	2	2	2	SM11/64 (40) × 8
C12	H3000D2020	Bushing	1	1	1	1	1	1	
C13	H3000D2030	Set screw	1	1	1	1	1	1	SM11/64 (40) × 4.35
C14	H30612D113	Needle bar connecting link guide	1	1	1	1	1	1	
C15	H005005050	Washer	1	1	1	1	1	1	
C16	HA304G0656	Screw	1	1	1	1	1	1	SM3/16 (28) × 15
C17	H3000D2110	Needle bearing	1	1	1	1	1	1	
C18	HA104G0654	Screw	1	1	1	1	1	1	SM1/8 (44) × 6
C19	H005004030	Washer	1	1	1	1	1	1	
C20	H3000D2130	Felt	1	1	1	1	1	1	
C21	HA100B2110	Set screw	2	2	2	2	2	2	SM11/64 (40) × 5.5
C22	H3010D0672	Bushing	1	1	1	1	1	1	
C23	H3010D0671	Needle feed rock shaft	1	1	1	1	1	1	
C24	H3009D0662	Pin	1	1	1	1	1	1	
C25	HA104G0012	Screw	1	1	1	1	1	1	SM3/16 (28) × 12
C26	H3009D0661	Lever	1	1	1	1	1	1	
C27	HA100B2110	Set screw	1	1	1	1	1	1	SM11/64 (40) × 5.5
C28	HA105D0662	Set screw	2	2	2	2	2	2	SM1/4 (40) × 4
C29	H3011D0681	Collar	1	1	1	1	1	1	
C30	H3010D0673	Bushing	1	1	1	1	1	1	
C31	H3010D0674	Washer	1	1	1	1	1	1	
C32	H007009150	Retaining ring	1	1	1	1	1	1	
C33	H3000B2110	Rubber plug	1	1	1	1	1	1	
C34	H3000D2050	Link	1	1	1	1	1	1	
C35	H3004D0651	Needle feed driving lever	1	1	1	1	1	1	
C36	HA304G0656	Set screw	1	1	1	1	1	1	SM3/16 (28) × 15
C37	H30611D713	Screw	1	1	1	1	1	1	SM1/8 (44) × 3.9
C38	H3000D2040	Eccentric pin	1	1	1	1	1	1	

D. ROTATING HOOK SHAFT MECHANISM

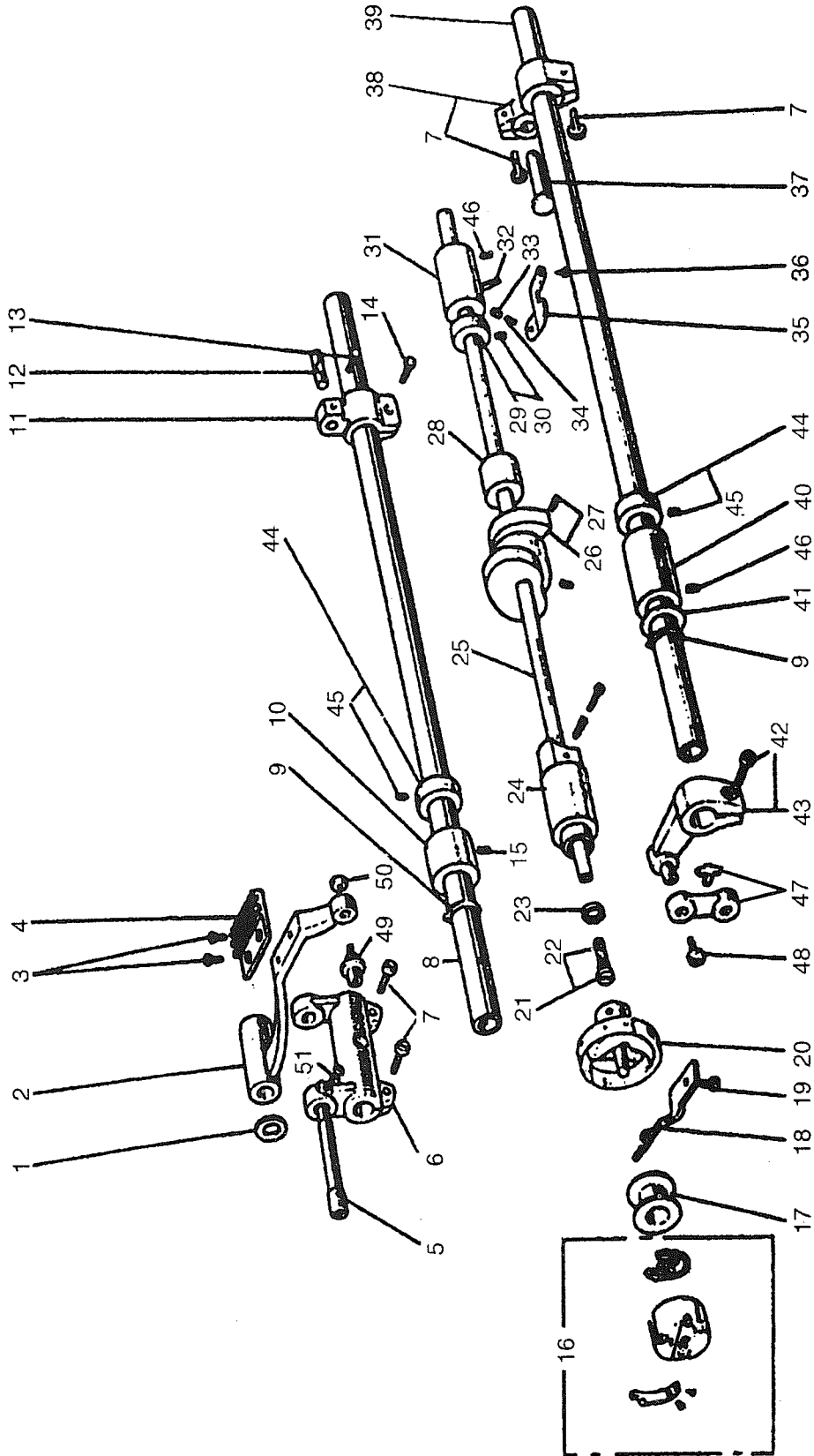

From the library of: Diamond Needle Corp

E. ROTATING HOOK SHAFT MECHANISM

Fig. No.	Part No.	Description	GC0518	GC0518A-D3	GC0518-H	GC0518-B	GC0518-H-D	GC0518-B-D	Remarks
D01	HA104G0656	Washer	1	1	1	1	1	1	
D02	H3006E2011	Feed bar assy.	1	1					
D02	HA705J0031	Feed bar assy.			1	1	1	1	
D03	HA104G0654	Screw	2	2	2	2	2	2	SM1/8(44) × 6
D04	H3000E2040	Feed dog	1	1					
D04	H7704E8001	Feed dog			1	1	1	1	
D05	HA705J0654	Shaft for feed bar(eccentric)	1	1	1	1	1	1	
D06	HA104G0011	Feed rock shaft crank	1	1	1	1	1	1	
D07	HA104G0012	Screw	4	4	4	4	4	4	SM3/16(28) × 12
D08	HA300G2050	Feed rock shaft	1	1	1	1	1	1	
D09	H007009150	Stop ring	2	2	2	2	2	2	
D10	HA100G2040	Feed rock shaft bushing	1	1	1	1	1	1	
D11	HA7311C706	Feed rock shaft crank(right)	1	1	1	1	1	1	
D12	HA706C11B2	Feed rock shaft crank pin	1	1	1	1	1	1	
D13	HA7311C806	Screw	2	2	2	2	2	2	SM11/64(40) × 7
D14	HA7311C606	Screw	1	1	1	1	1	1	SM11/64(40) × 12
D15	HA305E0662	Set screw	1	1	1	1	1	1	SM15/64(28) × 4.5
D16	H3005E0066	Bobbin case	1	1					
D16	HA805E0066	Bobbin case			1	1	1	1	
D17	HA700E2060	Bobbin	1	1					
D17	HA100E2170	Bobbin			1		1		
D17	H1100E2010	Bobbin				1		1	
D18	HA300E2050	Rotating hook positioner	1	1					
D18	H7707E8001	Rotating hook positioner				1		1	
D18	HA500E2020	Rotating hook positioner			1		1		
D19	HA100E2150	Screw	1	1	1	1	1	1	SM11/64(40) × 10
D20	H3004E0065	Rotating hook complete	1	1	1				
D20	HA606E0066	Rotating hook complete				1			
D20	HA804E0065	Rotating hook complete					1		
D20	HA906E0066	Rotating hook complete						1	
D21	HA104E0011	Filter assy.	1	1					
D21	H1005E7101	Filter assy.			1	1	1	1	
D22	HA1111E204	Filter	1	1					
D22	H1006E8001	Wick			1	1	1	1	
D23	HA700E2030	Oil seal for rotating hook shaft	1	1	1	1	1	1	
D24	HA704B0654	Hook shaft bushing(left)	1	1	1	1	1	1	
D25	HA304E0065	Rotating hook shaft assy.	1						
D25	H1004E7101	Rotating hook shaft assy.			1		1		
D25	H1106E7101	Rotating hook shaft assy.				1		1	
D25	HA704E65	Rotating hook shaft assy.		1					
D26	HA710E0691	Thread trimming eccentric		1			1	1	
D27	HA710E0692	Set screw		2			2	2	SM1/4(40) × 10
D28	HA704B0653	Hook shaft bushing(middle)		1			1	1	

D.LOWER SHAFT MECHANISM

Fig. No.	Part No.	Description	GC0518	GC0518A-D3	GC0518-H	GC0518-B	GC0518-H-D	GC0518-B-D	Remarks
D29	HA305E0066	Collar for rotating hook shaft	1	1	1	1	1	1	
D30	HA305E0662	Set screw	1	1	1	1	1	1	SM15/64(28) × 4.5
D31	HA311E0671	Hook shaft bushing(right)	1	1	1	1	1	1	
D32	HA110E0672	Oil pipe for hook shaft bushing	1	1	1	1	1	1	
D33	HA300E2100	Plunger	1	1	1	1	1	1	
D34	HA300E2110	Plunger spring	1	1	1	1	1	1	
D35	HA300E2040	Guide plate	1	1	1	1	1	1	
D36	HA104F0654	Set screw	1	1	1	1	1	1	SM15/64(28) × 10
D37	HA100G2070	Hinge pin	1	1	1	1	1	1	
D38	HA306G0067	Feed lifting rock shaft crank(right)	1	1	1	1	1	1	
D39	HA305G0663	Feed lifting rock shaft	1	1					
D39	HA704K0652	Feed lifting rock shaft			1	1	1	1	
D40	HA100G2120	Bushing	1	1	1	1	1	1	
D41	HA100G2130	Washer	1	1	1	1	1	1	
D42	HA111G0683	Set screw	1	1	1	1	1	1	SM11/64(40) × 12
D43	H3009E0068	Feed lifting rock shaft crank(left)	1	1					
D43	H1204D0651	Feed lifting rock shaft crank(left)			1	1	1	1	
D44	HA108G0066	Collar for feed lifting rock shaft	1	1	1	1	1	1	
D45	HA105D0662	Set screw	1	2	2	2	2	2	SM1/4(40) × 4
D46	HA100C2020	Set screw	1	4	4	4	4	4	SM15/64(28) × 10
D47	HA112G0070	Link assy.	1	2					
D48	HA100G2100	Screw	1	1					SM9/64(40) × 6.5
D49	HA104G0659	Stud screw	1	1					
D49	HA305G1012	Stud screw			1	1	1	1	
D50	HA104G0658	Nut	1	1					SM3/16(32)
D50	HA310G3011	Slide block			1	1	1	1	
D51	HA300C2030	Screw	1	1	1	1	1	1	SM11/64(40) × 8

E. STITCH LENGTH REGULATOR MECHANISM

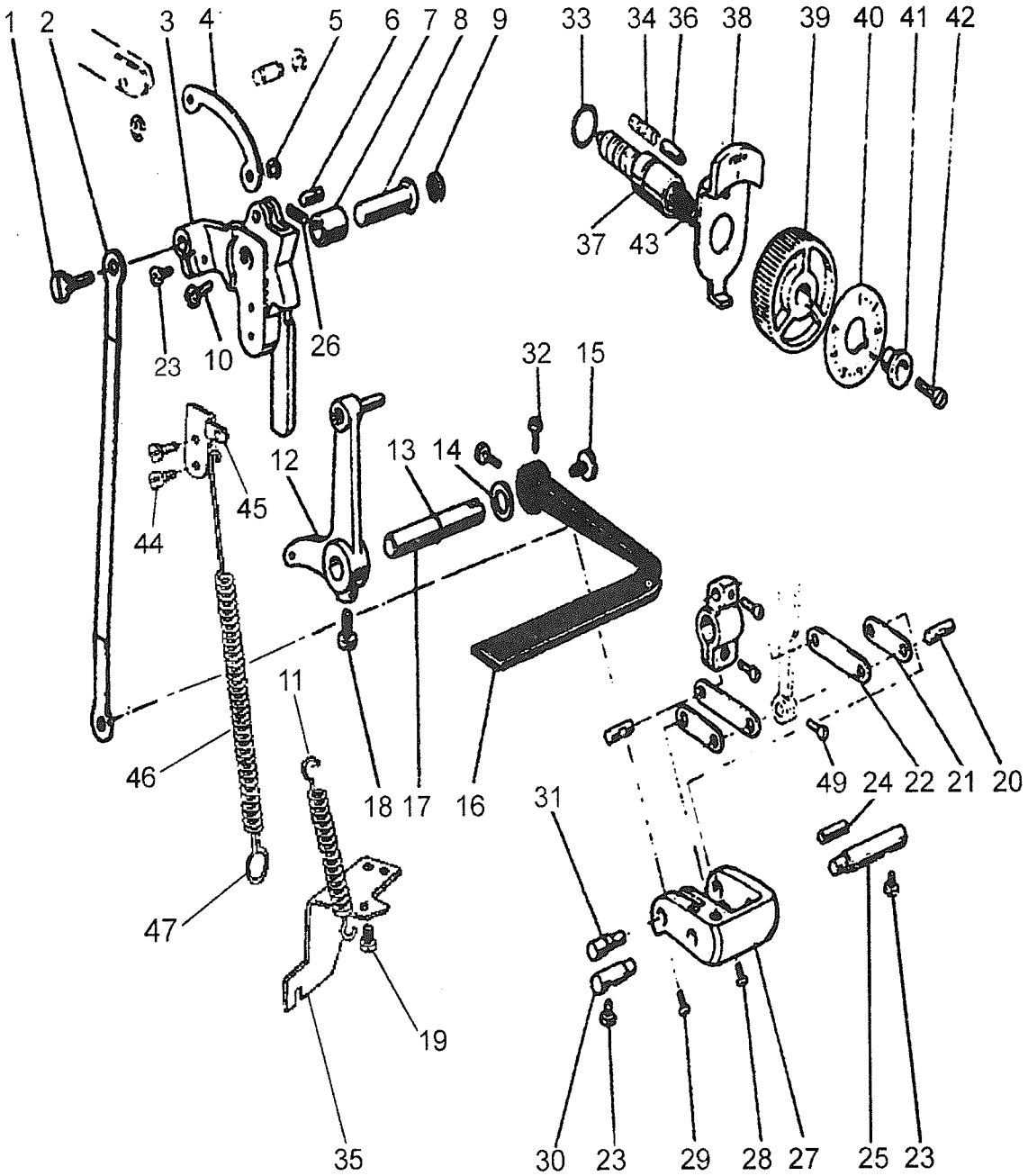

From the library of: Diamond Needle Corp

E.STITCH LENGTH REGULATOR MECHANISM

Fig. No.	Part No.	Description	GC0518	GC0518A-D3	GC0518-H	GC0518-B	GC0518-H-D	GC0518-B-D	Remarks
E01	H1204E0652	Connecting rod stud	1		1		1		
E01	H3000F2070	Connecting rod stud		1		1		1	
E02	HA7311C406	Feed rock regulator connecting rod	1		1		1		
E02	H3000F2010	Feed rock regulator connecting rod		1		1		1	
E03	H1204E0651	Feed regulator	1		1				
E03	H3005F0651	Feed regulator		1			1	1	
E03	H7705F8001	Feed regulator				1			
E04	H3000F2090	Link		1			1	1	
E05	H007013050	Retaining ring E type	1	1	1	1	1	1	
E06	H2204D0652	Link stud		1			1	1	
E07	HA704B0655	Bushing for feed regulator	1	1	1	1	1	1	
E08	HA100F2040	Connecting rod stud	1	1	1	1	1	1	
E09	HA700B2120	Rubber plug	1	1	1	1	1	1	
E10	HA113F0684	Screw	1	1	1	1	1	1	SM15/64(28) × 8.5
E11	HA115F0692	Coil spring	1		1	1			
E11	H3009F0663	Coil spring		1			1	1	
E12	HA115F0069	Reverse sewing crank assy.	1		1	1			
E12	H3009F0066	Reverse sewing crank assy.		1			1	1	
E13	HA113F3022	O-ring	1	1	1	1	1	1	
E14	HA100F2110	Spring washer	1	1	1	1	1	1	
E15	HA113F0683	Screw	1	1	1	1	1	1	SM3/16(28) × 6.5
E16	HA309F0671	Feed reversing lever	1	1	1	1	1	1	
E17	HA113F3021	Feed reversing lever shaft	1		1	1			
E17	H3008F0671	Feed reversing lever shaft		1			1	1	
E18	HA100F2130	Screw	1		1	1			SM15/64(28)
E19	HA800F2020	Screw		1			1	1	SM15/64 (28) × 13.5
E20	HA706C11B1	Link stud	1	1	1	1	1	1	
E21	HA706C1191	Link	2	2	2	2	2	2	
E22	HA706C1192	Link	2	2	2	2	2	2	
E23	HA111G0683	Screw	3	3	3	3	3	3	SM11/64 (40) × 12
E24	HA7311CE06	Link stud	1	1	1	1	1	1	
E25	HA700C2040	Feed regulator shaft	1	1	1	1	1	1	
E26	HA113F0684	Set screw	2	2	2	2	2	2	SM15/64 (28) × 10
E27	HA7311CG06	Stitch length adjusting crank	1	1	1	1	1	1	
E28	HA7311CD06	Screw	1	1	1	1	1	1	SM9/64 (40) × 8.5
E29	HA7311CC06	Screw	1	1	1	1	1	1	SM9/64 (40) × 6.5
E30	HA700C2050	Feed regulator shaft(left)	1	1	1	1	1	1	
E31	HA7311CF06	Link stud	1		1	1			
E31	H3000F2080	Link stud		1			1	1	
E32	HA104F0654	Screw	2	2	2	2	2	2	SM15/64 (28) × 10
E33	HA109F0674	O-ring	1	1	1	1	1	1	
E34	HA100F2090	Coil spring	1	1	1	1	1	1	
E35	H3000F2030	Spring holder		1			1	1	

E.STITCH LENGTH REGULATOR MECHANISM

Fig. No.	Part No.	Description	GC0518	GC0518A-D3	GC0518-H	GC0518-B	GC0518-H-D	GC0518-B-D	Remarks
E35	HA100F2140	Spring holder	1		1	1			
E36	HA700F2030	Stopper pin	1	1	1	1	1	1	
E37	HA720F0681	Screw bar	1	1	1	1	1	1	
E38	HA720F0683	Stopper pin releasing lever	1	1	1	1	1	1	
E39	HA7421F120	Dial	1	1	1	1	1	1	
E40	HA720F0684	Stitch length indicating plate	1	1					
E40	HD520F8001	Stitch length indicating plate			1	1	1	1	
E41	HA720F0685	Bushing	1	1	1	1	1	1	
E42	HA720F0686	Screw	1	1	1	1	1	1	
E43	HA720F0687	Coil spring	1	1	1	1	1	1	
E44	HA100C2190	Screw		2			2	2	SM9/64 (40) × 8
E45	H2600E2020	Spring holder		1			1	1	
E46	HA806C0674	Coil spring		1			1	1	
E47	HA806C0675	Coil spring pothook		1			1	1	

F.PRESSER FOOT MECHANISM

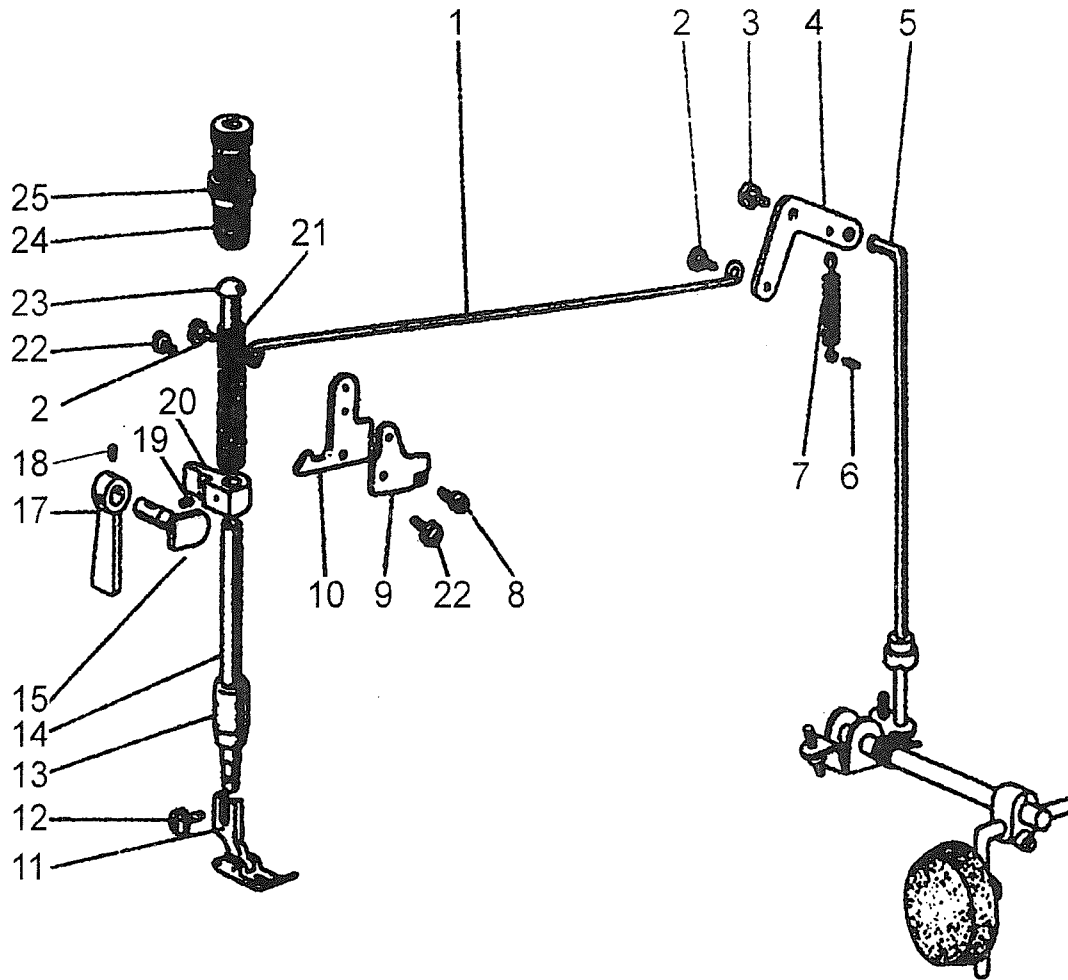

From the library of: Diamond Needle Corp

F.PRESSER FOOT MECHANISM

Fig. No.	Part No.	Description	GC0518	GC0518A-D3	GC0518-H	GC0518-B	GC0518-H-D	GC0518-B-D	Remarks
F01	HA107H0663	Knee lifter rod	1	1	1	1	1	1	
F02	HA107H0662	Hinged screw	2	2	2	2	2	2	SM3/16 (28) × 3.5
F03	HA100H2050	Stud bolt	1	1	1	1	1	1	SM15/64 (28) × 13.5
F04	HA306H0067	Knee lifter lever (right)	1	1	1	1	1	1	
F05	HA306H0671	Knee lifter connecting rod	1	1	1	1	1	1	
F06	HA100H2080	Spring hook	1	1	1	1	1	1	
F07	HA110H0672	Spring for knee lifter lever	1	1	1	1	1	1	
F08	HA100H2050	Stud bolt	1	1	1	1	1	1	SM15/64 (28) × 13.5
F09	HA305H6611	Tension releasing cam	1	1	1	1	1	1	
F10	HA7311I106	Knee lifter lever (left)	1	1	1	1	1	1	
F11	H3005G0066	Presser foot assy.	1	1	1	1			
F11	H7704G7101	Presser foot assy.					1	1	
F12	HA100H2150	Screw	1	1	1	1	1	1	SM9/64 (40) × 11
F13	HA704B0651	Bushing for presser bar	1	1	1	1	1	1	
F14	HA300H2110	Presser bar	1	1	1	1	1	1	
F15	HA705I0661	Presser bar lifting cam with O-ring	1	1	1	1	1	1	
F16	HA300H2080	O-ring	1	1	1	1	1	1	
F17	HA704I0652	Presser bar lifter with screw	1	1	1	1	1	1	
F18	HA100B2110	Set screw	1	1	1	1	1	1	SM11/64 (40) × 5.5
F19	HA3411D308	Set screw	1	1	1	1	1	1	SM15/64 (28) × 7
F20	H3004G0651	Presser bar guide bracket	1	1	1	1	1	1	
F21	HA300H2050	Presser spring	1	1					
F21	HA100H2130	Presser spring			1	1	1	1	
F22	HA107H0662	Screw	1	1	1	1	1	1	SM3/16 (28) × 3.5
F23	HA100H2120	Presser spring guide	1	1	1	1	1	1	
F24	HA309H0681	Thumb screw	1	1	1	1	1	1	
F25	HA117H0692	Thumb nut	1	1	1	1	1	1	

G.KNIFE ACTUATING MECHANISM

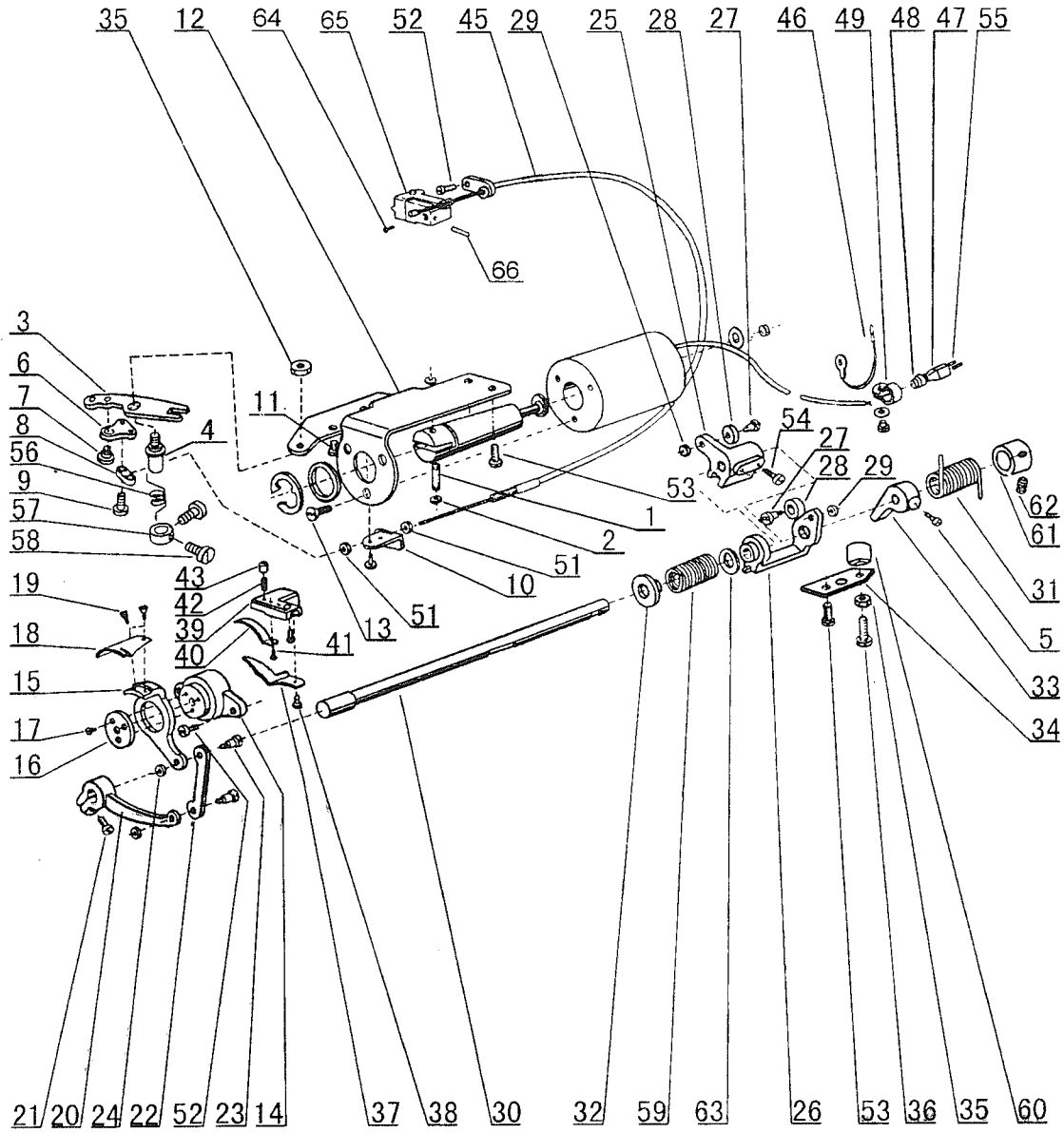

From the library of: Diamond Needle Corp

G.KNIFE ACTUATING MECHANISM

Fig. No.	Part No.	Description	GC0518	GC0518A-D3	GC0518-H	GC0518-B	GC0518-H-D	GC0518-B-D	Remarks
G01	HA712N0692	Link stud		1			1	1	
G02	H007013040	Retaining ring-E type		2			2	2	
G03	HA712N0698	Thread trimmer driving lever		1			1	1	
G04	HA712N0695	Stud screw		1			1	1	
G05	HA113F0684	Set screw		2			2	2	SM15/64 (28) × 8.5
G06	HA712N6910	Flexible wire holder		1			1	1	
G07	HA712N0699	Stud screw		1			1	1	SM11/64 (40) × 4
G08	HA712N6911	Flexible wire presser		1			1	1	
G09	HA712N6912	Screw		2			2	2	SM1/8 (44) × 7
G10	HA712N6913	Holder		1			1	1	
G11	HA100E2150	Screw		1			1	1	SM11/64 (40) × 10
G12	HA7511N212	Solenoid breaket		1			1	1	
G13	HS90011406	Screw		3			3	3	M4×6
G14	HA704N1111	Knife holding bracket saddle		1			1	1	
G15	HA704N1112	Knife base (left)		1			1		
G15	211H205	Knife base (left)						1	
G16	HA704N1113	Thrust collar		1			1		
G16	211H305	Thrust collar						1	
G17	HA704N1114	Screw		3			3		SM1/8 (44) × 5.2
G17	211H405	Screw						3	
G18	HA7111N804	Movable knife (left)		1			1		
G18	HA9111N204	Movable knife (left)						1	
G19	HA7111N704	Screw		2			2	2	SM11/64 (40) × 5.5
G20	HA7111N604	Knife driving crank		1			1	1	
G21	HA719B7011	Screw		1			1	1	SM11/64 (40) × 11.4
G22	HA7111N404	Link		1			1	1	
G23	HA7111N204	Stud screw		2			2	2	SM11/64 (40) × 6.2
G24	HA7111N304	Nut		2			2	2	SM11/64 (40)
G25	HA7211N106	Cam follower crank1		1			1	1	
G26	HA7211N206	Cam follower crank2		1			1	1	
G27	HA7221N206	Roller stud		1			1	1	
G28	HA7221N106	Roller		1			1	1	
G29	HA706N0663	Nut		1			1	1	SM3/16 (28)
G30	HA700N0020	Knife driving shaft		1			1		
G30	HA900N0020	Knife driving shaft						1	
G31	HA700N0110	Coil spring		1			1	1	
G32	HA700N0050	Bushing		1			1	1	
G33	HA709N0671	Stopper lever		1			1		
G33	HA906N0661	Stopper lever						1	
G34	HA710N0682	Lever stopper plate		1			1	1	
G35	HA710N0683	Nut		2			2	2	
G36	HA7411N110	Bolt		1			1	1	SM15/64 (28) × 23
G37	HA7121N404	Fixed blade		1			1	1	

G.KNIFE ACTUATING MECHANISM

Fig. No.	Part No.	Description	GC0518	GC0518A-D3	GC0518-H	GC0518-B	GC0518-H-D	GC0518-B-D	Remarks
G38	HA7311CH06	Screw		1			1	1	SM9/64 (40) × 8
G39	HA7121N104	Bracket for fixed blade		1			1	1	
G40	H3000H2030	Fixed blade		1					
G40	H22121H104	Fixed blade					1	1	
G41	HA7121N304	Screw		1			1	1	SM9/64 (40) × 5
G42	HA7121N604	Screw		1			1	1	SM9/64 (40) × 8.5
G43	HA7121N704	Nut		1			1	1	SM9/64 (40)
G45	HA713N0070	Flexible wire		1			1	1	
G46	HA705Q0065	Ground wire assy.		1			1	1	
G47	HA700Q0010	Nylon connectoe oil seal		1			1	1	
G48	HA70400657	Connector cap		1			1	1	
G49	HA708P0668	Cord holder		1			1	1	
G50	HA300B2170	Screw		1			1	1	SM11/64 (40) × 9
G51	H003002050	Nut		2			2	2	
G52	HA300C2030	Screw		6			6	6	SM11/64 (40) × 8
G53	HA700N0080	Screw		4			4	4	SM15/64 (28) × 12
G54	HA113F0684	Set screw		2			2	2	
G55	HA7641B319	Terminal pin		2			2	2	
G56	HA712N0697	Trimming lever spring		1			1	1	
G57	HA712N0696	Spring support collar		1			1	1	
G58	HA7311CC06	Screw		2			2	2	SM9/64 (40) × 6.5
G59	HA700N0040	Coil spring		1			1	1	
G60	HA7411N210	Washer		1			1	1	
G61	HA715N0711	Collar		1			1	1	
G62	HA105D0662	Set screw		1			1	1	SM1/4 (40) × 4
G63	HA706N0664	Bushing		1			1	1	
G64	HA7311C606	Screw		2			2	2	SM11/64 (40) × 12
G65	H5904H7101	Thread tension releasing bracket assy.		1			1	1	
G65	H3600G2010	Thread tension releasing bracket	1		1	1			
G66	HA100H2060	Thread tension releasing pin	1		1	1			
G66	H3000H2060	Thread tension releasing pin		1			1	1	

H.WIPER MECHANISM

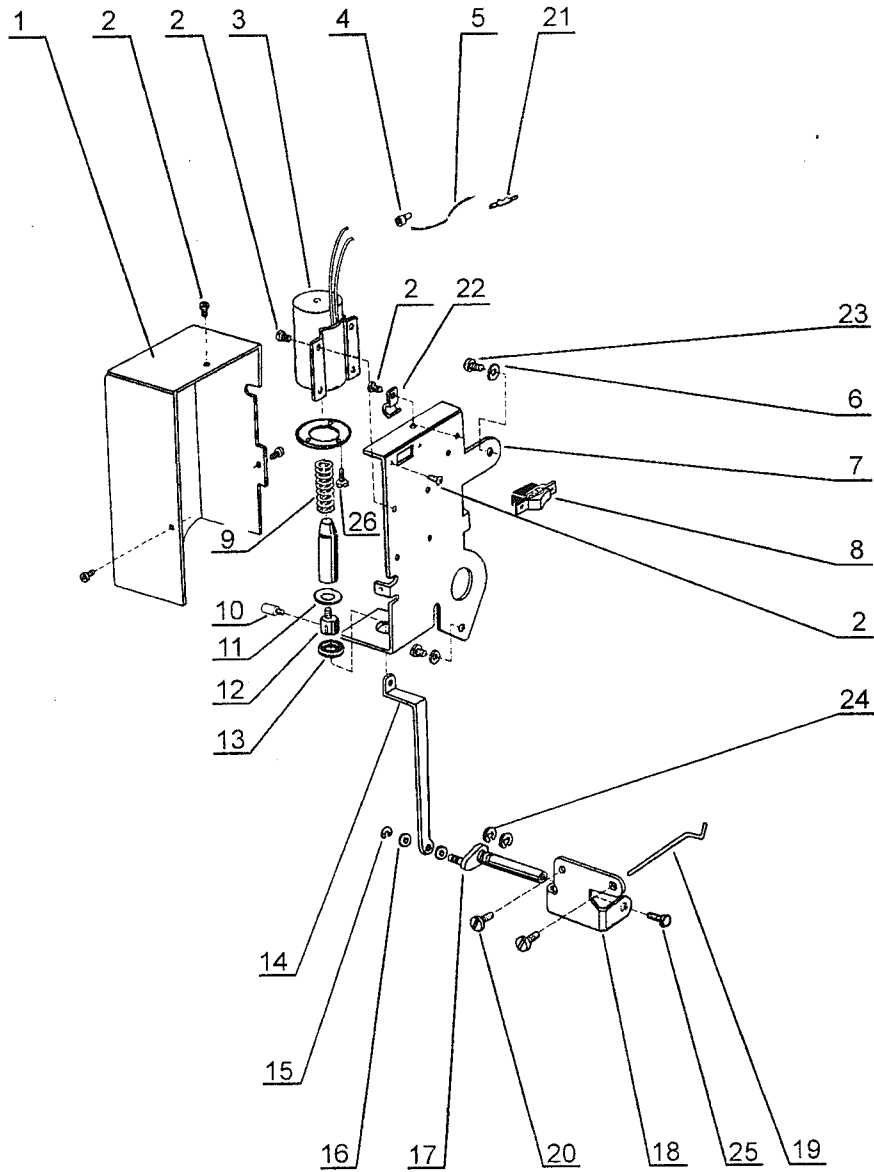

From the library of: Diamond Needle Corp

H. WIPER MECHANISM

Fig. No.	Part No.	Description	GC0518	GC0518A-D3	GC0518-H	GC0518-B	GC0518-H-D	GC0518-B-D	Remarks
H01	H3000I2040	Solenoid cover for wiper mech.		1			1		
H02	HA708P0669	Screw		10			10		
H03	HA7221P108	Thread wiper solenoid assy.		1			1		
H04	HA708P6610	Connecting		1			1		
H05	HA708P1011	Vinyl cap-tire cable assy.		1			1		
H06	HA700P0010	Washer		2			2		
H07	HA708P0667	Solenoid bracket		1			1		
H08	HA708P0665	Thread wiper switch		1			1		
H09	HA708P0663	Coil spring		1			1		
H10	HA700P0030	Plunger pin		1			1		
H11	HA7221P308	Washer		1			1		
H12	HA7221P408	Screw		1			1		
H13	HA708P0664	Rubber cushion		1			1		
H14	HA705P0654	Thread wiper connecting rod		1			1		
H15	H007013025	Retaining ring-E type		1			1		
H16	HA705P0655	Washer		2			2		
H17	HA7121P105	Wiper shaft		1			1		
H18	HA705P0651	Thread wiper brachet		1			1		
H19	H3000I2020	Thread wiper		1			1		
H20	HA700B2030	Screw		2			2		
H21	HA7641B319	Terminal pin		2			2		
H22	HA700P0060	Cord holder		1			1		
H23	HA104F0654	Screw		2			2		
H24	H007013040	Retaining ring-E type		2			2		
H25	HA104G0654	Screw		1			1		
H26	HA7221P508	Screw		3			3		

I. TOUCH BACK MECHANISM

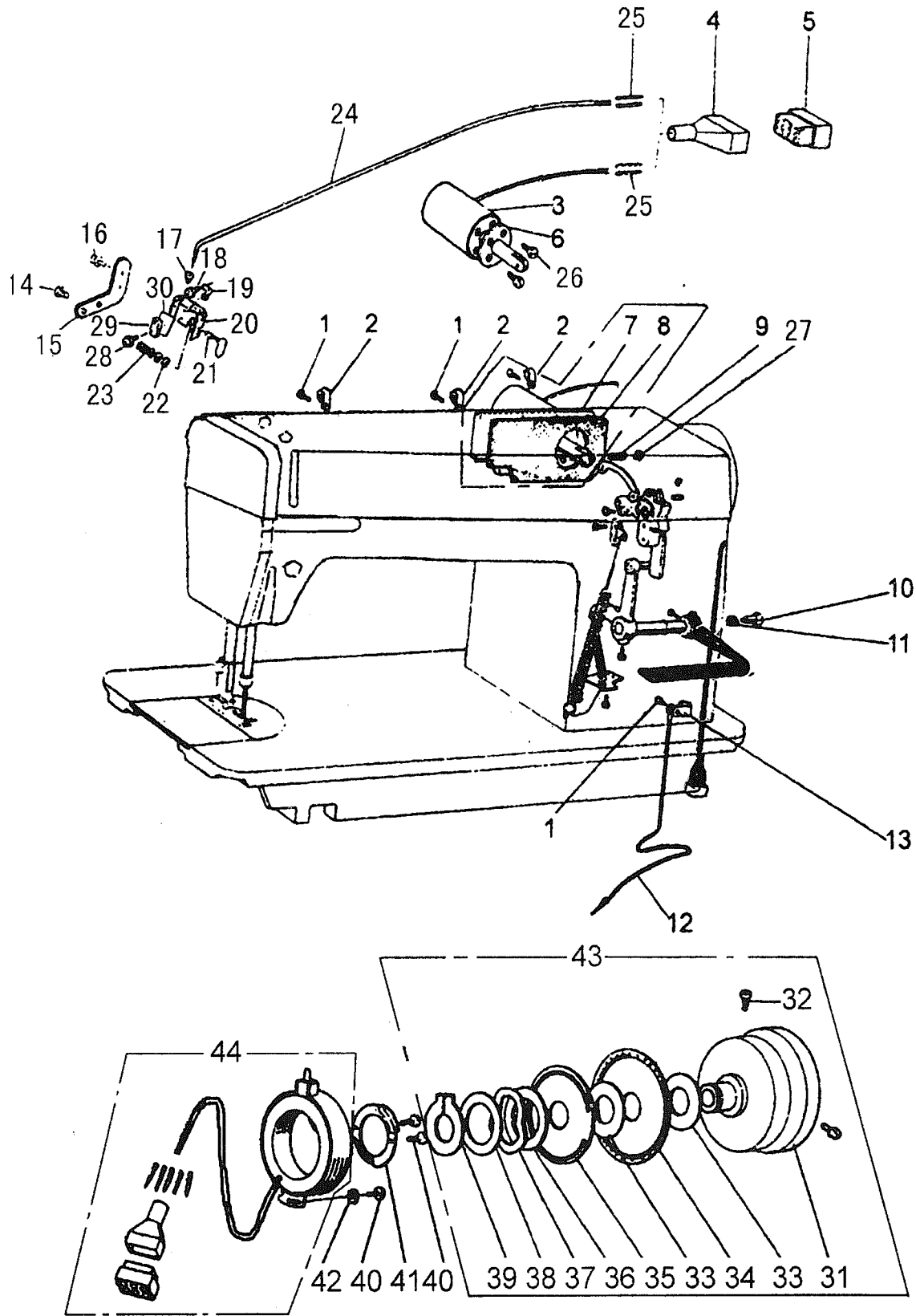

From the library of: Diamond Needle Corp

I.TOUCH BACK MECHANISM

Fig. No.	Part No.	Description	GC0518	GC0518A-D3	GC0518-H	GC0518-B	GC0518-H-D	GC0518-B-D	Remarks
I01	HA300B2170	Screw assy.		4			4	4	SM11/64 (40) × 9
I02	HA700Q0030	Cord holder		3			3	3	
I03	H2206I0673	Arm side cover solenoid assy.		1			1	1	
I04	HA712Q0693	Connector cap		1			1	1	
I05	HA700Q0010	Nylon connector		1			1	1	
I06	H2206I0672	Gascket for solenoid oil seal		1			1	1	
I07	HA108B0681	Arm side cover	1		1	1			
I07	H2609E0671	Arm side cover		1			1	1	
I08	HA108B0682	Gascket for arm side cover	1		1	1			
I08	H2609E0672	Gascket for arm side cover		1			1	1	
I09	HA712N0692	Link stud		1			1	1	
I10	H2204G0651	Stud screw		1			1	1	SM15/64 (28) × 7
I11	H2204G0652	Rubber cushion		1			1	1	
I12	HA705Q0065	Ground wire assy.		1			1	1	
I13	HA700Q0050	Cord holder		1			1	1	
I14	HA300B2170	Screw		2			2	2	SM11/64 (40) × 9
I15	H5911J8001	Touch switch plate		1			1	1	
I16	HA7221P508	Screw		2			2	2	M3 × 5
I17	HA70400657	Rubber busher		1			1	1	
I18	HA70400659	Screw		1			1	1	M2 × 4
I19	HA70400654	Spring		1			1	1	
I20	H2205I0661	Switch plate		1			1	1	
I21	HA70400021	Switch assy.		1			1	1	
I22	H007013030	Retaining ring-E type		2			2	2	GB/T896 3
I23	HA70400653	Spring		1			1	1	
I24	HA7641B319	Cable assy.		3			3	3	
I25	HA7641B319	Terminal pin		5			5	5	
I26	HA300C2030	Screw		4			4	4	SM11/64 (40) × 8
I27	H007013040	Retaining ring-E type		1			1	1	GB/T896 4
I28	HA70406510	Screw		2			2	2	M2 × 8
I29	HA70400655	Switch		1			1	1	
I30	HA70400658	Insulating plate		2			2	2	
I31	HA307D0067	Pulley	1		1	1			
I31	HA710R0065	Pulley		1			1	1	
I32	HA110D0672	Set screw	2	2	2	2	2	2	
I33	HA700R0030	Spacer1		2			2	2	
I34	HA700R0010	Speed command disc1		1			1	1	
I35	HA700R0020	Spacer2		1			1	1	
I36	HA700R0040	Speed command disc2		1			1	1	
I37	HA700R0050	Supporter spring		1			1	1	
I38	HA700R0060	Washer		1			1	1	
I39	H007009300	Retaining ring-C type		1			1	1	
I40	HA300C2030	Screw		3			3	3	SM11/64 (40) × 8

I.TOUCH BACK MECHANISM

Fig. No.	Part No.	Description	GC0518	GC0518A-D3	GC0518-H	GC0518-B	GC0518-H-D	GC0518-B-D	Remarks
I41	HA703R0066	Detector bracket supporter		1			1	1	
I42	HA703R0067	Washer		1			1	1	
I43	HA700R0000	Pulley assy.		1			1	1	
I44	HA703R0065	Detector bracket assy.		1			1	1	

J.OIL LUBRICATION MECHANISM

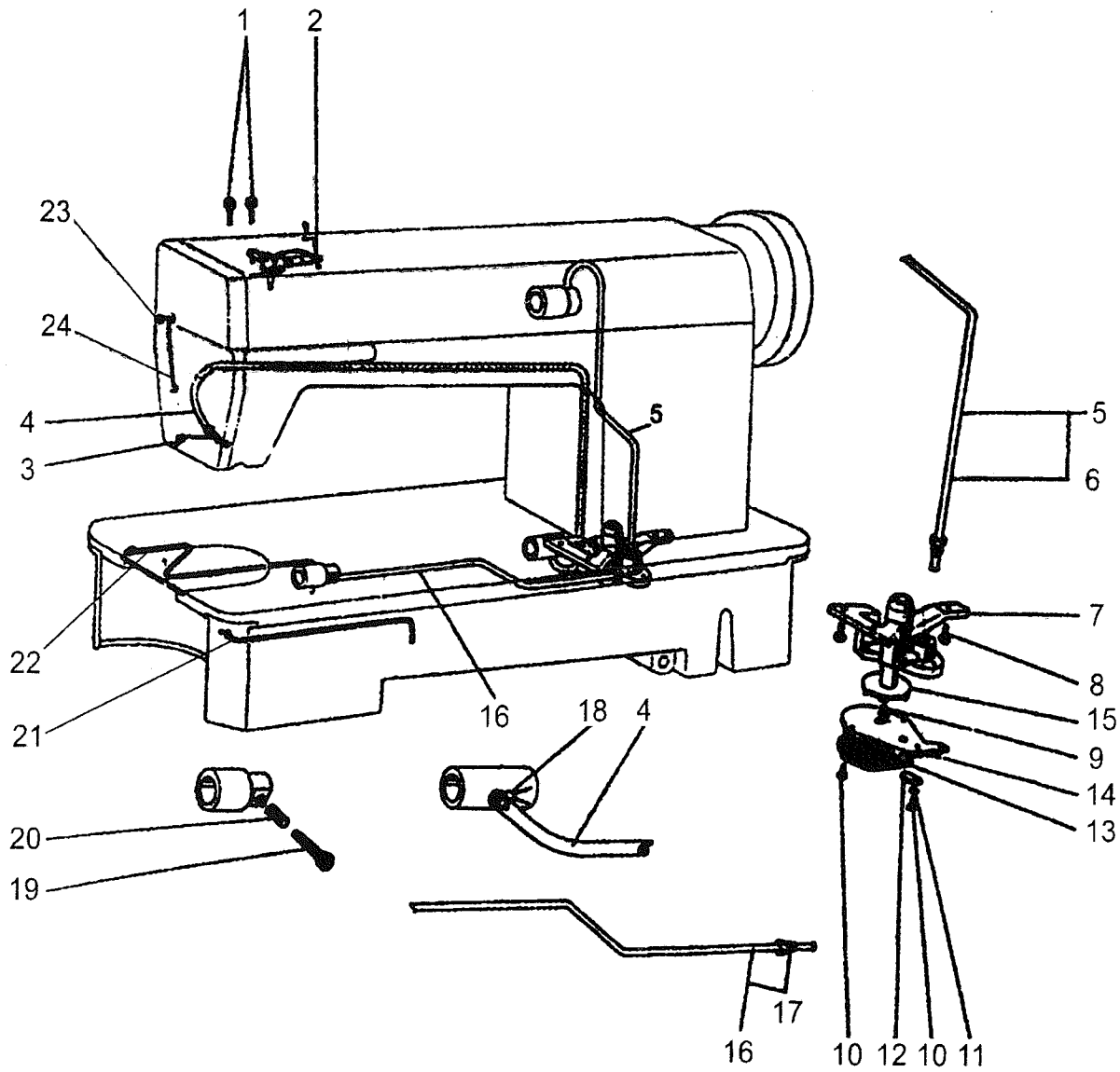

From the library of: Diamond Needle Corp

J.OIL LUBRICATION MECHANISM

Fig. No.	Part No.	Description	GC0518	GC0518A-D3	GC0518-H	GC0518-B	GC0518-H-D	GC0518-B-D	Remarks
J01	HA100H2150	Screw	2	2	2	2	2	2	SM9/64 (40) × 11
J02	H3004L0065	Oil wick fitting plate assy.	1	1	1	1	1	1	
J03	H3000L0020	Oil filter holder	1	1	1	1	1	1	
J04	H3006L0065	Oil return tube assy.	1	1	1	1	1	1	
J05	HA116I0068	Upper shaft oil tube assy.	1	1	1	1	1	1	
J06	HA116I0682	Oil tube lock bushing	1	1	1	1	1	1	
J07	HA100I2010	Oil pump	1	1	1	1	1	1	
J08	HA100I2090	Screw	3	3	3	3	3	3	SM11/64 (40) × 13
J09	HA100I2030	Screw	1	1	1	1	1	1	SM1/8 (44) × 6.5
J10	HA100I2040	Screw	3	3	3	3	3	3	SM1/8 (44) × 13
J11	HA100I2050	Spring washer	1	1	1	1	1	1	
J12	HA100I2070	Oil adjusting plate	1	1	1	1	1	1	
J13	HA111I0065	Oil pump filter	1	1	1	1	1	1	
J14	HA700L0030	Oil pump impeller cover	1	1	1	1	1	1	
J15	HA100I2020	Oil pump impeller	1	1	1	1	1	1	
J16	HA707L0065	Lower shaft oil tube assy.	1	1	1	1	1	1	
J17	HA113I0661	Oil tube lock bushing	1	1	1	1	1	1	
J18	HA300I2030	Oil return tube clip	1	1	1	1	1	1	
J19	HA300E2030	Oil adjusting screw	1	1	1	1	1	1	SM15/64 (28) × 12
J20	HA100E2060	Oil adjusting spring	1	1	1	1	1	1	
J21	HA305G0664	Oil wick	1	1	1	1	1	1	
J22	H3000E2050	Oil wick	1	1	1	1	1	1	
J23	HA300C2030	Screw	1	1	1	1	1	1	SM11/64 (40) × 8
J24	H3000L0030	Oil pipe holder	1	1	1	1	1	1	

K.ACCESSORIES

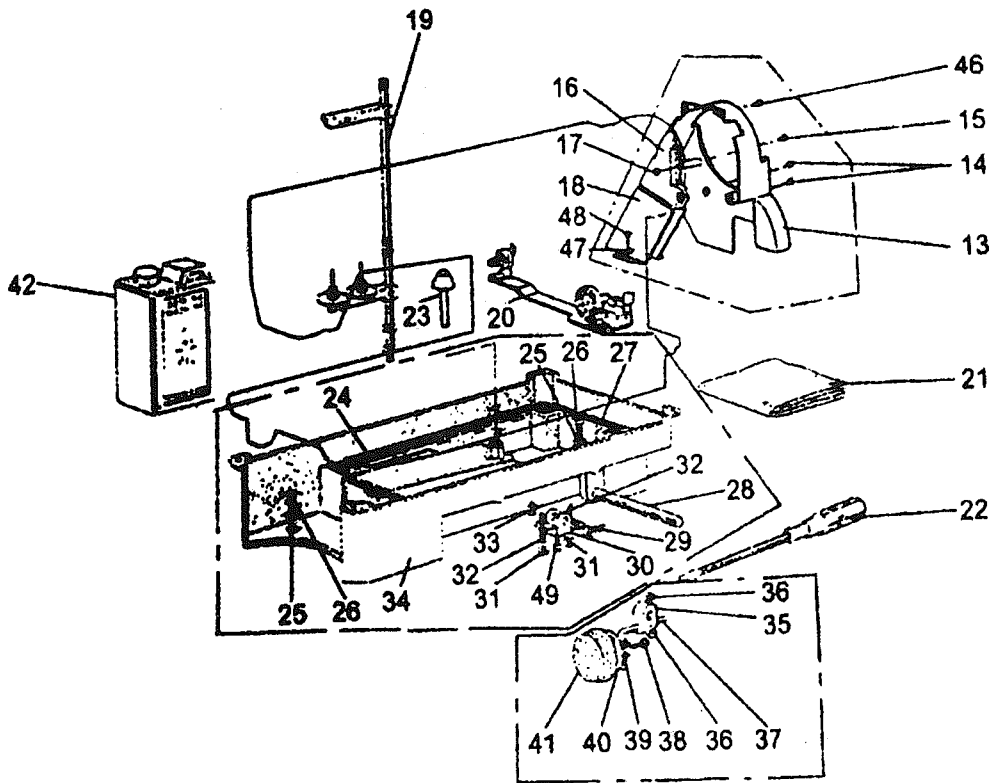
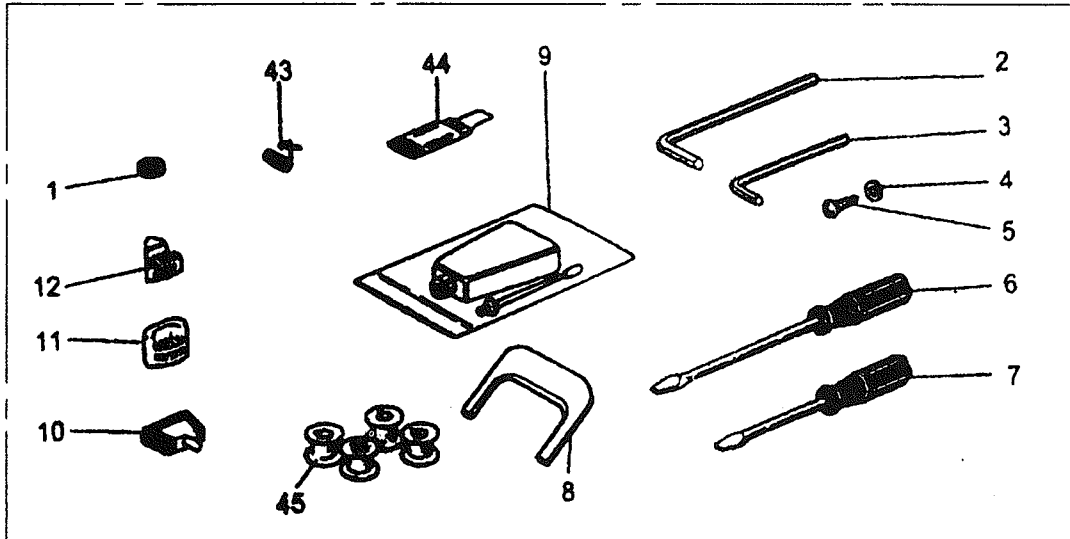

K.ACCESSORIES

Fig. No.	Part No.	Description	GC0518	GC0518A-D3	GC0518-H	GC0518-B	GC0518-H-D	GC0518-B-D	Remarks
K01	HA100J2120	Magnet block	1	1	1	1	1	1	
K02		Hexagon socket screw key 3	1	1	1	1	1	1	
K03	HA704S0653	Hexagon socket screw key 2	1	1	1	1	1	1	
K04	HA300J2230	Washer	2	2	2	2	2	2	
K05	H801045200	Wood screw	2	2	2	2	2	2	
K06	HA300J2200	Screw driver (Size M)	1	1	1	1	1	1	
K07	HA300J2210	Screw driver (Size S)	1	1	1	1	1	1	
K08	HA704S0654	Speed command disc adjusting plate		1			1	1	
K09	HA100J2110	Oil with oiler	1	1	1	1	1	1	
K10	HA307J0067	Hinge with rubber cushion	1	1	1	1	1	1	
K11	HA300J2050	Head cushion (large)	2	2	2	2	2	2	
K12	HA300J2060	Head cushion (small)	2	2	2	2	2	2	
K13	HA305J0666	Belt cover	1	1	1	1	1	1	
K14	HA300J2280	Set screw	2	2	2	2	2	2	SM15/64 (28) × 8
K15	HA300J2250	Screw	1	1	1	1	1	1	M4 × 12.5
K16	HA305J0662	Belt cover complete	1	1	1	1	1	1	
K17	H003002040	Nut	1	1	1	1	1	1	M4
K18	HA305J0665	Belt cover	1	1	1	1	1	1	
K19	HA707S0068	Thread stand complete	1	1	1	1	1	1	
K20	HA706S0067	Robbin winder complete	1	1	1	1	1	1	
K21	HA300J2190	Head cover	1	1	1	1	1	1	
K22	HA300J2130	Screw driver (Size L)	1	1	1	1	1	1	
K23	HA106J0661	Knee lifter lifting rod	1	1	1	1	1	1	
K24	HA104J0654	Gasket for oil reservoir (small)	1	1	1	1	1	1	
K25	HA104J0653	Seal washer	2	2	2	2	2	2	
K26	HA104J0652	Oil drain screw	2	2	2	2	2	2	SM5/16 (28) × 10
K27	HA104J0655	Gasket for oil reservoir (large)	1	1	1	1	1	1	
K28	HA300J2160	Knee lifter shaft	1	1	1	1	1	1	
K29	HA104J0657	Knee lifter spring	1	1	1	1	1	1	
K30	HA104J0658	Knee lifter	1	1	1	1	1	1	
K31	HA104J6510	Nut	2	2	2	2	2	2	SM5/16 (28)
K32	HA104J0659	Set screw	2	2	2	2	2	2	SM15/64 (28) × 28
K33	H007013090	E-type ring	1	1	1	1	1	1	
K34	HA304J0651	Oil reservoir	1	1	1	1	1	1	
K35	HA106J0663	Knee lifter coupling joint	1	1	1	1	1	1	
K36	HA300J2180	Bolt	2	2	2	2	2	2	SM5/16 (18) × 16
K37	HA106J0662	Knee lifter bell crank	1	1	1	1	1	1	
K38	HA106J0667	Screw	1	1	1	1	1	1	SM15/64 (28) × 8
K39	HA106J0666	Gasket for knee lifter plate	1	1	1	1	1	1	
K40	HA106J0665	Knee lifter plate	1	1	1	1	1	1	
K41	HA106J0668	Pad for knee plate	1	1	1	1	1	1	
K42	HA300J2170	Oil tank	1	1	1	1	1	1	
K43	HA115B0706	Thread take-up spring	1	1	1	1	1	1	

K.ACCESSORIES

Fig. No.	Part No.	Description	GC0518	GC0518A-D3	GC0518-H	GC0518-B	GC0518-H-D	GC0518-B-D	Remarks
K44	HA300J2310	Needle	4	4					
K44	H1000C2010	Needle			4		4		
K44	HA500C2040	Needle				4		4	
K45	HA700E2060	Bobbin	3	3					
K45	HA100E2170	Bobbin			3				
K45	H2604D8001	Bobbin					3		
K45	H1100E2010	Bobbin				3		3	
K46	HA300B2170	Screw	2	2	2	2	2	2	SM11/64 (40) × 8
K47	HA300J2230	Washer	2	2	2	2	2	2	
K48	H801045200	Wood screw	2	2	2	2	2	2	

SHANGHAI HUIGONG NO.3 SEWING MACHINE FACTORY

ADD: 1418, Yishan Road, Shanghai, China

Zip Code: 201103

Overseas Business: TEL: 86-21-64853303 FAX: 86-21-64854304

E-mail: highlead@online.sh.cn <http://www.highlead.com.cn>

The description covered in this manual is subject to change for improvement of the commodity without notice

2005.3. Printed