

**HIGHLEAD**

**GA2698-1**

**Long Arm Cylinder Bed Transverse Seam  
Lockstitch Sewing Machine**

**Instruction Manual  
Parts Catalog**

---

## --- CONTENT ---

### **Instruction Manual**

1、 PRECAUTIONS BEFORE STARTING OPERATION .....	2
(1) Safety Precautions .....	2
(2) Precautions before Starting Operation .....	2
(3) Precautions for Operating Conditions .....	2
2、 MAIN SPECIFICATION .....	2
3、 PREPARATION FOR OPERATION .....	3
(1) Cleaning the machine .....	3
(2) Examination .....	3
(3) Lubrication .....	3
(4) Testing .....	3
4、 REPLACE NEEDLES .....	4
5、 WINDING OF BOBBIN THREAD .....	4
6、 ADJUSTMENT OF THE BOBBIN WINDER .....	4
(1) In case of uneven winding .....	4
(2) Winding amount of thread .....	4
(3) Winding strength .....	4
7、 THREADING .....	5
8、 REMOVING AND INSERTING THE BOBBIN .....	5
(1) Removing .....	5
(2) Installation .....	5
9、 ADJUSTING THE THREAD TENSION .....	5
(1) Tension of the Upper thread .....	5
(2) Tension of the Lower thread .....	5
10、 ADJUSTMENT OF PRESSER FOOT PRESSURE .....	5
11、 ADJUSTMENT OF STITCH LENGTH AND FORWARD/BACKWARD SEWING .....	6
12、 FEED DOG HEIGHT .....	6
13、 ADJUSTING THE HEIGHT OF THE NEEDLE BAR .....	6
14、 USING OF THE HAND WHEEL .....	6

### **Parts Catalog**

.....	7-27
-------	------

---

## 1. PRECAUTIONS BEFORE STARTING OPERATION

### 1) Safety Precautions:

- (1) When turning the power on, keep your hands and fingers away from the area around/under the needle and the area around the balance wheel.
- (2) Power must be turned off when the machine is not in use, or when the operator leaves the seat.
- (3) Power must be turned off when tilting the machine head, installing or removing the “V” belt, adjusting the machine, or when replacing.
- (4) Avoid placing fingers, hairs, bars etc., near the balance wheel, “V” belt, bobbin winder balance wheel, or motor when the machine is in operation.
- (5) Do not insert fingers into the thread take-up cover, under/around the needle, or balance wheel when the machine is in operation.
- (6) If a belt cover, finger guard, eye guard are installed, do not operate the machine without these safety devices.

### 2) Precautions before Starting Operation:

- (1) If the machine’s oil pan has an oil sump, never operate the machine before filling it.
- (2) If the machine is lubricated by a drop oiler, never operate the machine before lubricating.
- (3) When a new sewing machine is first turned on, verify the rotational direction of the balance wheel with the power on. (The balance wheel should rotate counter-clockwise when viewed from the balance wheel.)
- (4) Verify the voltage and (single or three) phase with those given on the machine nameplate.

### 3) Precautions for Operating Conditions:

- (1) Avoid using the machine at abnormally high temperature (35°C or higher) or low temperature (5°C or lower) .
- (2) Avoid using the machine in dusty conditions.

## 2. MAIN SPECIFICATIONS

Max. Speed(rpm)		800
Needle		DY×3 26#
Needle Bar Stroke(mm)		56
Thread Take-up Lever Stroke(mm)		96
Stitch Length(mm)		7.5
Presser-Foot Stroke	By Hand	13
	By Knee	20

---

### 3. PREPARATION FOR OPERATION

#### 1) Cleaning the machine

Before leaving the factory, the machine parts are coated with rust-preventive grease, which may be hardened and contaminated by dust during storage and shipment. This grease must be removed with gasoline.

#### 2) Examination

Though every machine is confirmed by strict inspection and test before leaving the factory, the machine parts may be loose or deformed after long distance transportation with jolt. A thorough examination must be performed after cleaning the machine. Turn the balance wheel to see if there is running obstruction, parts collision, uneven resistance or abnormal noise. If these exist, adjustment must be made accordingly before run-in operation.

#### 3) Lubrication (Fig.1.1、 Fig.1.2)

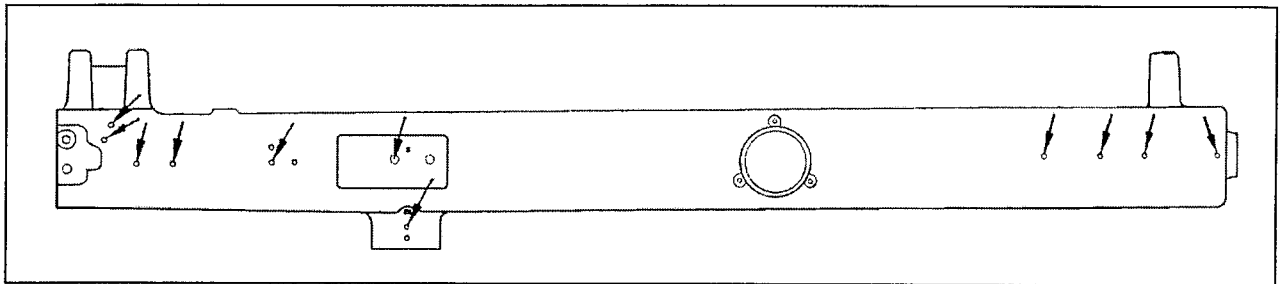

Fig.1.1

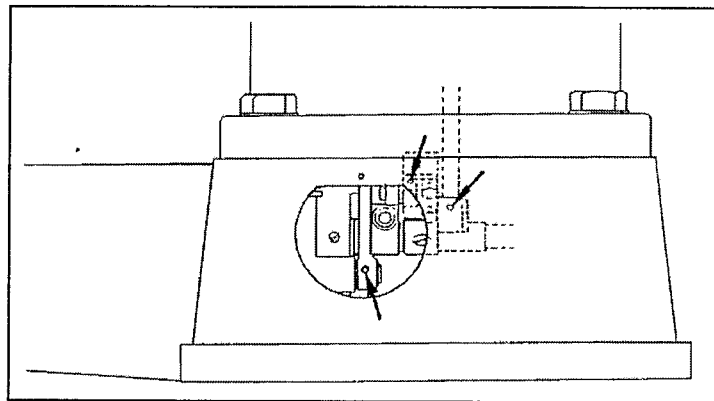

Fig.1.2

When a new sewing machine is used for the first time, or sewing machine left out of use for considerably long time is used again, replenish a suitable amount of oil to the portions indicated by arrow in below figure. CAUTION: Please use white spindle oil.

Always keep the presser foot lifted before attempting a dry run.

#### 4) Testing

In order to get the best working situation, run the sewing machine in a low speed for about 1 month after lubricated fully. Then increase the speed to the need one.

CAUTION: Before using the following procedures, be sure to turn the power switch off. The needle used by this sewing machine is DY×3 26#. During operation, proper needle can be chosen according to the sewing thread. (the sewing thread should be able to pass the pinhole.)

#### 4. REPLACE NEEDLES (Fig.2)

CAUTION: Before using the following procedures, be sure to turn the power switch off. The needle used by this sewing machine is DY×3 26#. Turn the balance wheel to lift needle bar to the upper end of its stroke. Loosen needle clamp screw (A). While keeping the long groove of the needle leftward fully insert the needle shank up to the bottom of the needle socket. Then tighten needle clamp screw (A).

Note: Fig. (b): insufficient insertion.

Fig. (c): wrong direction of long groove.

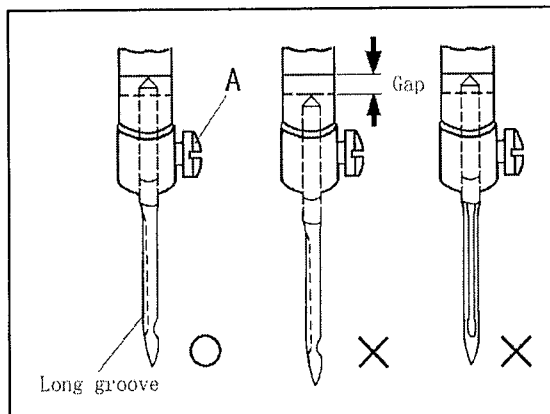

Fig.2

#### 5. WINDING OF BOBBIN THREAD (Fig.3)

- (1) Push the bobbin 3 on the bobbin winder shaft as far as it will go.
- (2) Bring the thread forward toward the bobbin and wind from below in clockwise direction several times around the bobbin.
- (3) Push the lever 5 toward other side so that the driving wheel and driven wheel will engage and then start the machine.
- (4) The driven wheel will automatically be free from the driving wheel and stop after the bobbin is filled with thread.

#### 6. ADJUSTMENT OF THE BOBBIN WINDER (Fig.3)

##### 1) In case of uneven winding

If the thread does not wind evenly on the bobbin, loosen the nut 1 and move the bracket 2 to the right or to the left as may be required, then tighten the nut.

##### 2) Winding amount of thread

Loose the screw 6. move adjusting plate 5 towards the axis can decrease the amount of thread winding on the bobbin, and move backwards can increase it.

##### 3) Winding strength

Strength of the winding can be adjusted with the nut 1.

#### 7. THREADING (Fig.4)

Raise the needle bar to its highest position and route the upper thread in the order illustrated beside.

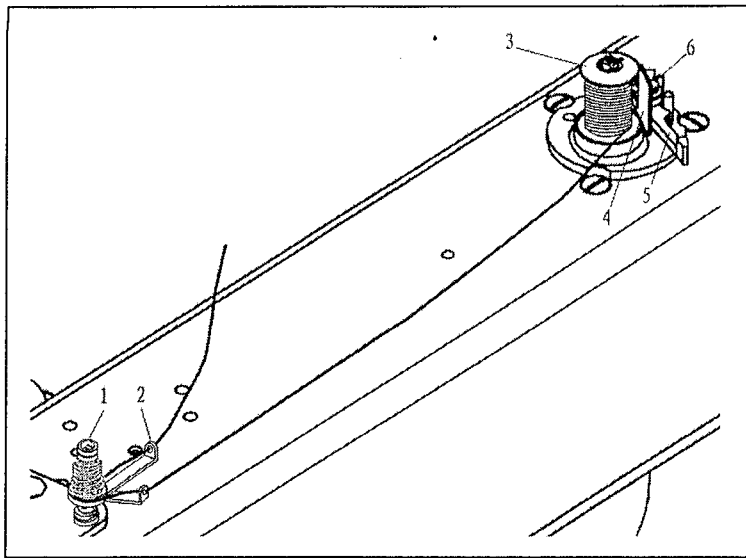

Fig.3

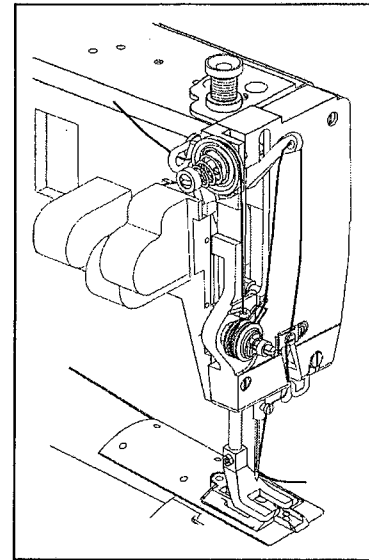

Fig.4

## 8. REMOVING AND INSERTING THE BOBBIN

- (1) Removing: Open the shuttle race cap and the bobbin holder, then take out the bobbin.
- (2) Installation: Put the bobbin in the rotary hook case, Permit about 5 cm of bobbin thread to hang down freely. Install the bobbin in the bobbin case so that the thread wound direction is clockwise. Then close the rotary hook and the shuttle race cap.

## 9. ADJUSTING THE THREAD TENSION (Fig.5)

For ordinary stitching, the tension of the upper and the lower threads should be equal.

### 1) Tension of the upper thread

Before adjusting the tension of the upper thread, be sure that presser foot is let down. To adjust tension, turn serrated nut on tension device to the right (clockwise) to increase tension and to the left (counter-clockwise) if you desire to decrease the tension.

### 2) Tension of the lower thread

The lower thread tension is controlled by the larger screw near the end of the spring at the outside of the bobbin case. Turning this screw to the right (clockwise) will increase the thread tension, while turning it to the left (counter-clockwise) will decrease the tension.

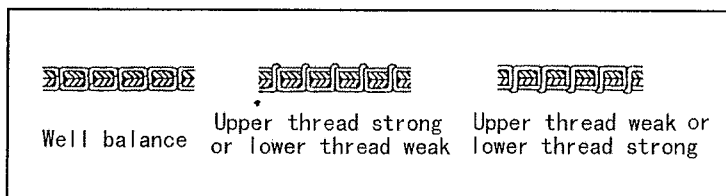

Fig.5

## 10. ADJUSTMENT OF PRESSER FOOT PRESSURE (Fig.6)

- (1) Pressure should be adjusted according to the material to be sewn.
- (2) Pressure on both the walking foot and the presser foot can be adjusted. (The adjusting screw has been set before shipment.)
- (3) Sewing pressure should be adjusted to the minimum required strength.

## 11. ADJUSTMENT OF STITCH LENGTH AND FORWARD/BACKWARD SEWING

(Fig.7)

- (1) Stitch length can be changed by the stitch length adjusting bolt.
- (2) Stitch length can be adjusted between 0-8mm.
- (3) Setting the stitch length adjusting bolt upside can sewing ahead, and setting it downside can go backstitch.

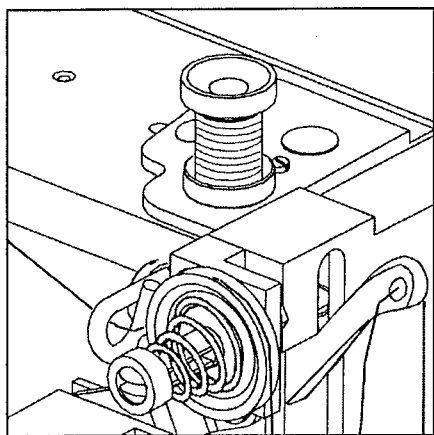

Fig.6

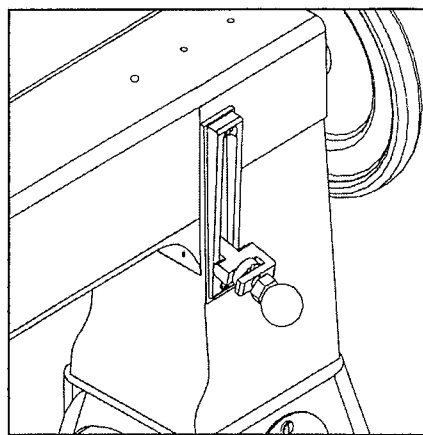

Fig.7

## 12. FEED DOG HEIGHT (Fig.8)

The feed dog should be 1.5mm higher than the vertex of the needle plate. Adjustment of the feed dog height can be done as follows:

- (1) Turn the stitch length to the minimum position.
- (2) Turn the machine balance wheel so as to raise the feed dog to its highest point.
- (3) Loosen the screw of the feed dog 1 and adjust the height of part 2 by raising or lowering it. Then tighten the screw 1.

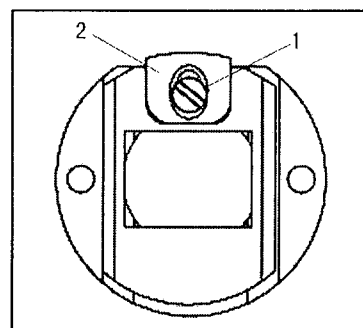

Fig.8

## 13. ADJUSTING THE HEIGHT OF THE NEEDLE BAR

When the needle bar is at its highest point, normally the measurement between the highest point of the needle plate and the needlepoint is 28 mm. When this distance need to be adjusted, the steps is as follows:

- (1) Take down the face plate, adjust the needle bar to its highest position.
- (2) Loosen the screw of needle bar connecting stud screw.
- (3) Adjust the needle bar to the right position.
- (4) Tighten the screw.

## 14. USING OF THE HAND WHEEL (Fig.9)

If you want to change the position of the needle when the machine is not running, you can use the hand wheel. Just push the hand wheel in and make the clutch connected then rotate it.

Caution: forbid to push the hand wheel when the machine is running.

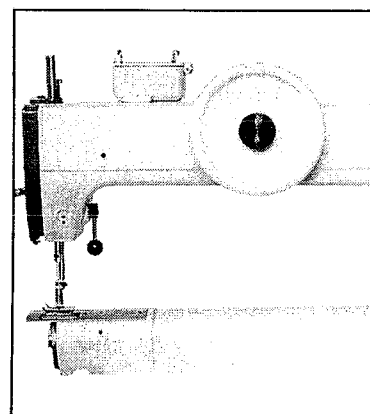
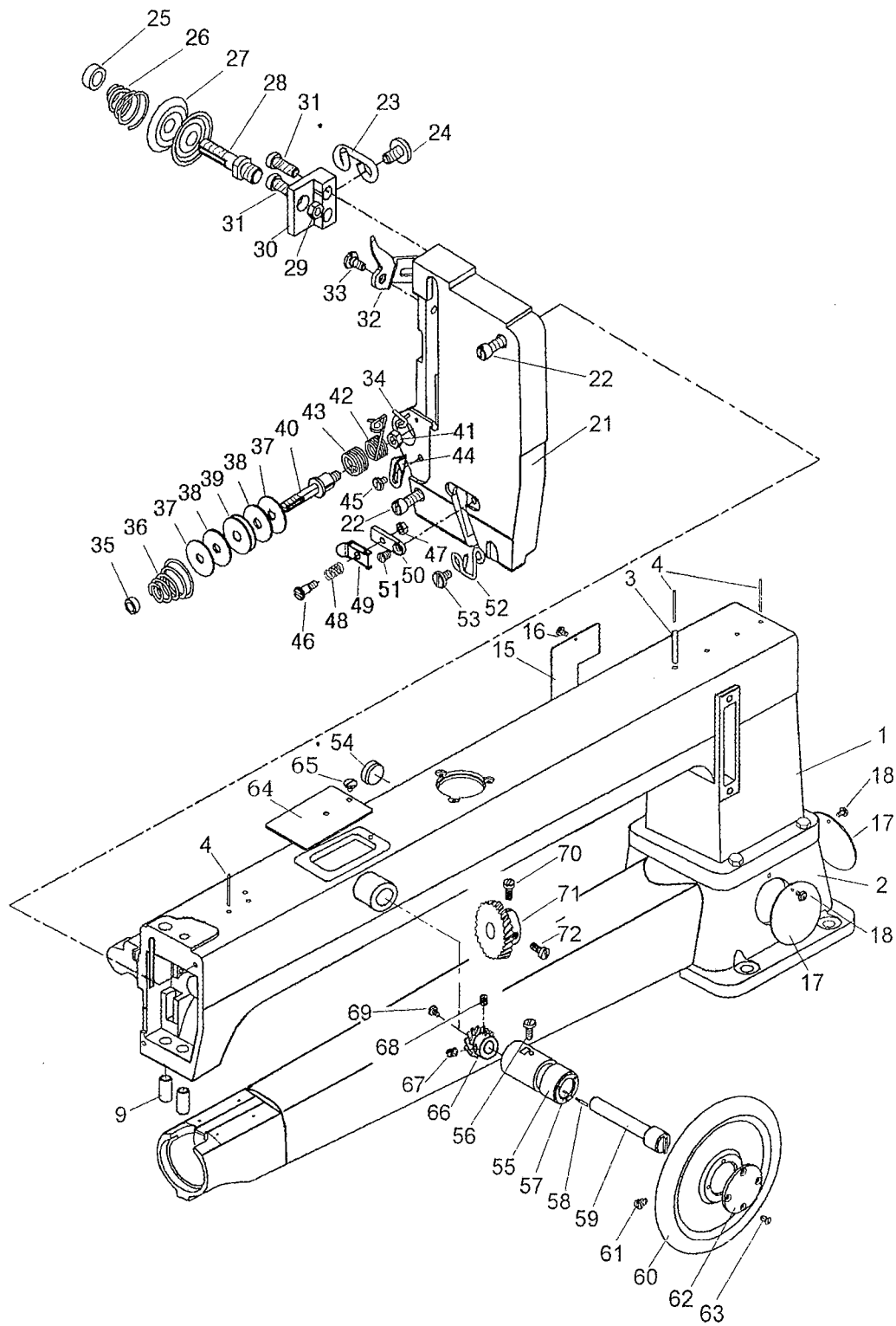

Fig.9

# A. ARM BED AND ITS ACCESSORIES





# A. ARM BED AND ITS ACCESSORIES

Fig. No.	Part No.	Description	Pcs.	Remarks
A01	HD607B8001	Arm	1	
A02	HD609B8001	Bed	1	
A03	H7215B8001	Oil pipe	1	
A04	H7216B8001	Oil wick	3	
A09	H7218B8001	Presser bar bushing	1	
A15	H7225B8001	Arm side cover	1	
A16	HA100B2060	Screw	1	SM11/64 (40) × 9
A17	H7228B8001	Round cover	2	
A18	HA100B2060	Screw	2	SM11/64 (40) × 9
A21	H7236B8001	Face plate	1	
A22	H7238B8001	Screw	2	SM15/64 (28) × 22
A23	H7240B8001	Thread guide	1	
A24	H3410C301K	Screw	1	SM9/64 (40) × 6.5
A25	HA115B0702	Nut	1	
A26	H7241B8001	Tension spring	1	
A27	HA310B0705	Tension disc	2	
A28	H7242B8001	Tension screw stud	1	SM9/32 (28)
A29	H2010J0066	Tension nut	1	SM9/32 (28)
A30	H7243B8001	Thread tension regulator complete base	1	
A31	HA111G0683	Screw	2	SM11/64 (40) × 12
A32	H7244B8001	Tension releasing disc	1	
A33	H7245B8001	Screw	1	SM3/16 (28)
A34	H7246B8001	Thread guide	1	
A35	HA115B0702	Tension nut	1	
A36	H7241B8001	Tension spring	1	
A37	H7248B8001	Washer	2	
A38	H7249B8001	Felt	2	
A39	H7250B8001	Damping plate	1	
A40	H7251B8001	Tension screw stud	1	SM15/64 (28)
A41	HA710N0683	Nut	1	SM15/64 (28)
A42	H7253B8001	Thread take-up spring	1	
A43	H7254B8001	Spring	1	
A44	H7255B8001	Thread take-up spring guide plate	1	
A45	H3410C301K	Screw	1	SM9/64 (40) × 6.5
A46	H7257B8001	Screw	1	SM1/8 (44)
A47	H7258B8001	Nut	1	SM1/8 (44)
A48	H7259B8001	Tension spring	1	
A49	H7260B8001	Tension disc	1	
A50	H7261B8001	Thread tension regulator complete base	1	
A51	HA7311CC06	Screw	1	SM9/64 (40) × 6
A52	H7262B8001	Thread guide	1	
A53	H3410C301K	Screw	1	SM9/64 (40) × 6.5
A54	HA300B2100	Rubber plug	1	

# A. ARM BED AND ITS ACCESSORIES

Fig. No.	Part No.	Description	Pcs.	Remarks
A55	HE957B8001	Bushing	1	
A56	HE040D8001	Screw	1	SM17/64 (24) × 17.5
A57	HE962B8001	Spring	3	
A58	HE961B8001	Pin	3	
A59	HE965B8001	Hand wheel shaft	1	
A60	HE963B8001	Hand wheel	1	
A61	HE966B8001	Screw	2	SM1/4 (32) × 6
A62	HE965B8001	Cover	1	
A63	HA700F2100	Screw	4	SM11/64 (40)
A64	HE951B8001	Top cover	1	
A65	H2015I0065	Screw	1	SM3/16 (28)
A66	HE958B8001	Gear	1	
A67	HE017G8001	Screw	1	SM1/4 (32) × 5.5
A68	HE023C8001	Screw	1	SM1/4 (32) × 5.5
A69	HE007C8001	Screw	1	SM17/64 (24) × 11
A70	HE960B8001	Screw	1	SM1/4 (32) × 11
A71	H8921B8001	Gear	1	
A72	HE022G8001	Screw	1	SM1/4 (32) × 10.5

# B. NEEDLE BAR AND THREAD TAKE-UP MECHANISM

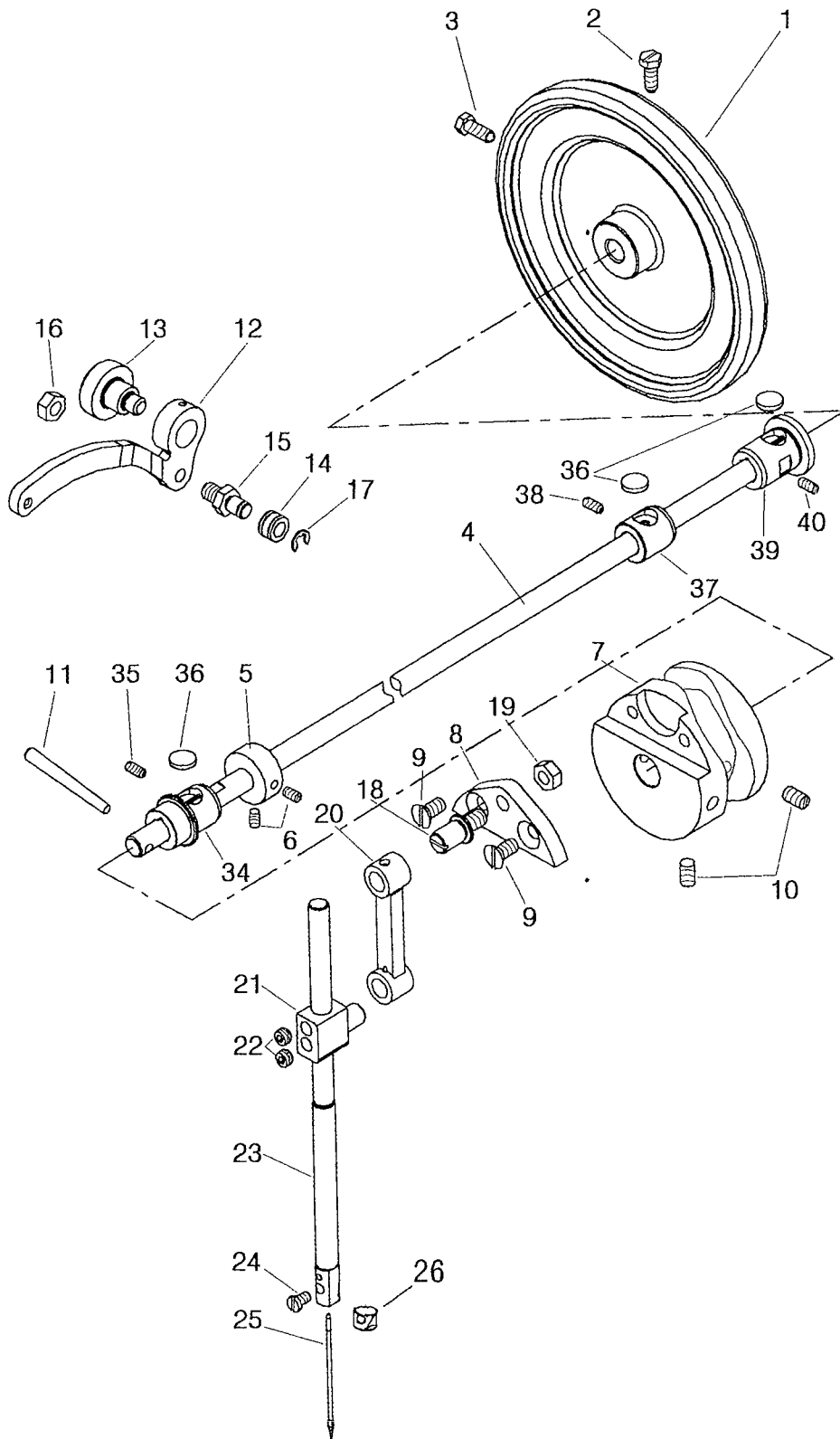

From the library of: Diamond Needle Corp

## B. NEEDLE BAR AND THREAD TAKE-UP MECHANISM

Fig. No.	Part No.	Description	Pcs.	Remarks
B01	H7204C8001	Pulley	1	
B02	H7205C8001	Screw	1	SM5/16(24) × 19
B03	H7206C8001	Screw	1	SM5/16(24) × 19
B04	H8905C8001	Arm shaft	1	
B05	HA108G0661	Collar	1	
B06	HA105D0662	Set Screw	2	SM1/4(40) × 6
B07	H7209C8001	Thread take-up cam	1	
B08	H7210C8001	Needle bar connecting base link screw	1	
B09	H403060120	Screw	2	M6 × 12
B10	H4933K8001	Set Screw	2	SM1/4(40) × 10
B11	H602040450	Pin	1	
B12	H7211C8001	Thread take-up lever	1	
B13	H7212C8001	Screw	1	SM5/16(24) × 7.5
B14	H7213C8001	Roller	1	
B15	H7214C8001	Roller pin	1	
B16	H2010J0066	Nut	1	SM9/32(28)
B17	H007013050	Retaining ring-E type	1	
B18	H7215C8001	Needle bar connecting link screw	1	SM9/32(28) × 11.5
B19	H2010J0066	Nut	1	SM9/32(28)
B20	H7216C8001	Needle bar connecting link	1	
B21	H9006C8001	Needle bar connecting stud	1	
B22	HA800F2020	Set Screw	2	SM1/4(40) × 4.5
B23	H9007C8001	Needle bar	1	
B24	HA700F2100	Screw	1	SM11/64(40) × 7
B25	H7220C8001	Needle	1	DY*3 26#
B26	H9010C8001	Thread pass bushing	1	
B34	H7213B8001	Bushing	1	
B35	H2405D0664	Set Screw	1	SM15/64(28) × 14
B36	H7214B8001	Felt	3	
B37	H7212B8001	Bushing	1	
B38	H2405D0664	Set Screw	1	SM15/64(28) × 14
B39	H7211B8001	Bushing	1	
B40	H2405D0664	Set Screw	1	SM15/64(28) × 14

# C. LOWER SHAFT MECHANISM

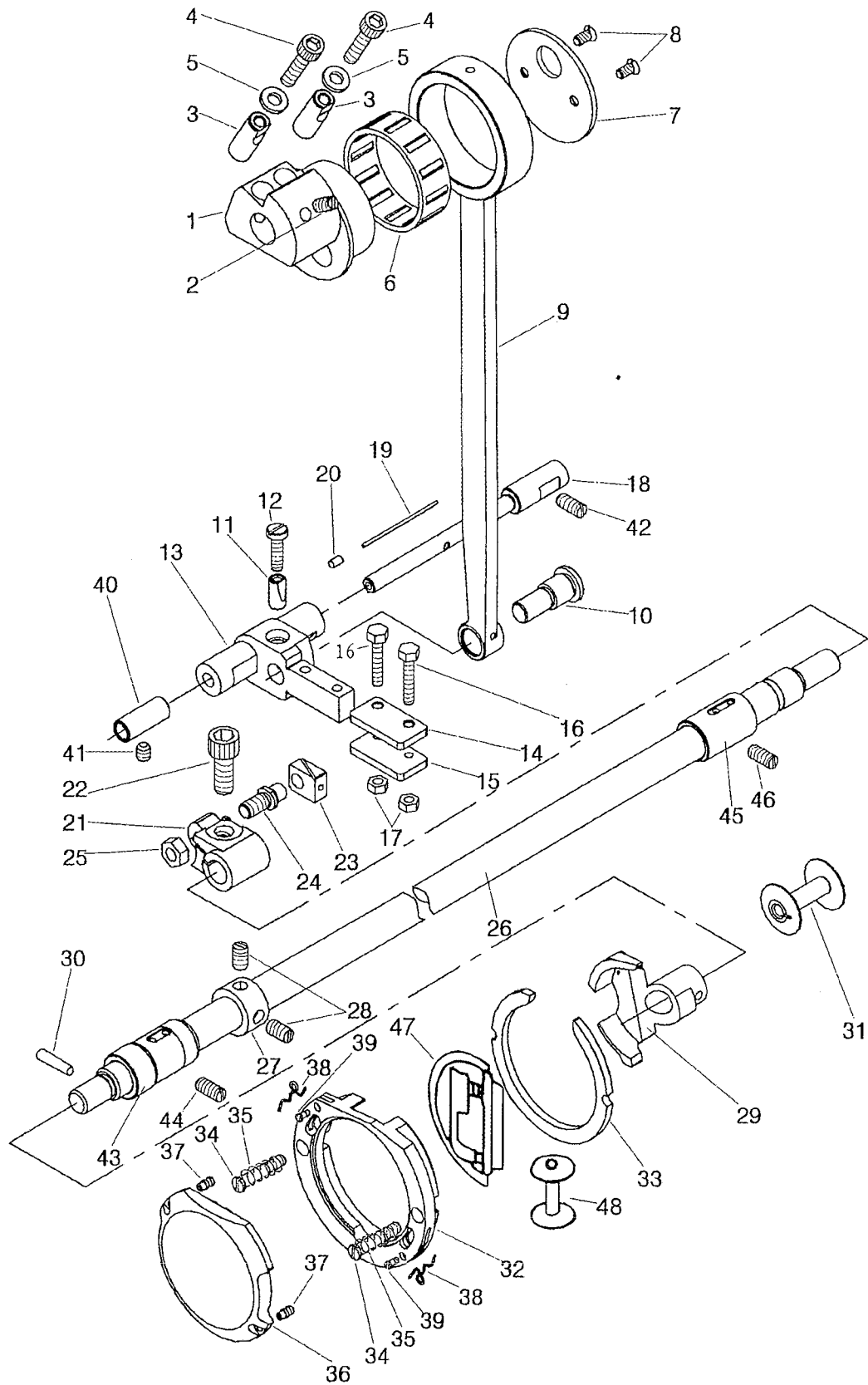

## C. LOWER SHAFT MACHANISM

Fig. No.	Part No.	Description	Pcs.	Remarks
C01	H7204D8001	Eccentric	1	
C02	H7205D8001	Set Srew	1	SM15/64(28) × 12
C03	H7206D8001	pin	2	
C04	H415060250	Screw	2	M6 × 25
C05	H4728H8001	Washer	2	
C06	H7237D8001	Bearing	1	K43 × 48 × 17 (NTN)
C07	H7207D8001	Eccentric cover	1	
C08	H2000B2050	Screw	2	SM11/64(40) × 9
C09	H7208D8001	Crank connecting rod	1	
C10	H7209D8001	Crank connecting rod pin	1	
C11	H7210D8001	Pin	1	
C12	H7211D8001	Screw	1	SM3/16(32) × 18
C13	H7213D8001	Shuttle shaft	1	
C14	H7214D8001	Plate	1	
C15	H7215D8001	Plate	1	
C16	H7216D8001	Screw	2	SM11/64(40)
C17	H2000M0120	Nut	2	SM11/64(40)
C18	H7218D8001	Inside Shaft	1	
C19	H7219D8001	Oil wick	1	
C20	H7220D8001	Rivet	1	
C21	H7222D8001	Lower shaft crank	1	
C22	H415080200	Screw	1	M8 × 20
C23	H7223D8001	Shuttle shaft slide block	1	
C24	H7224D8001	Screw	1	
C25	H2010J0066	Nut	1	SM9/32(28)
C26	H8905D8001	Lower shaft	1	
C27	HA108G0661	Collar	1	
C28	H7239D8001	Set Screw	2	SM1/4(40) × 3.5
C29	H9005D8001	Shuttle driver	1	
C30	H602040180	Pin	1	
C31	H7228D8001	Bobbin	1	
C32	H7229D8001	Shuttle race body	1	
C33	H7230D8001	Shuttle race back ring	1	
C34	H7231D8001	Screw	2	SM3/16(32)
C35	H7232D8001	Spring	2	
C36	H7233D8001	Shuttle race cap	1	
C37	H7234D8001	Screw	2	SM1/8(44)
C38	H7235D8001	Spring	2	
C39	H7236D8001	Screw	2	SM3/32(56)
C40	H7234B8001	Bushing	1	
C41	HA3411D308	Set Screw	1	SM15/64(28) × 7
C42	HA100C2020	Set Screw	1	SM15/64(28) × 10
C43	H7230B8001	Bushing	1	

C. LOWER SHAFT MACHANISM

Fig. No.	Part No.	Description	Pcs.	Remarks
C44	H2405D0664	Set Screw	1	SM15/64 (28) × 14
C45	H7229B8001	Bushing	1	
C46	H2405D0664	Set Screw	1	SM15/64 (28) × 14
C47	H7240D8001	Shuttle hook complete	1	
C48	H7228D8001	Bobbin	1	

# D. FEEDING MECHANISM

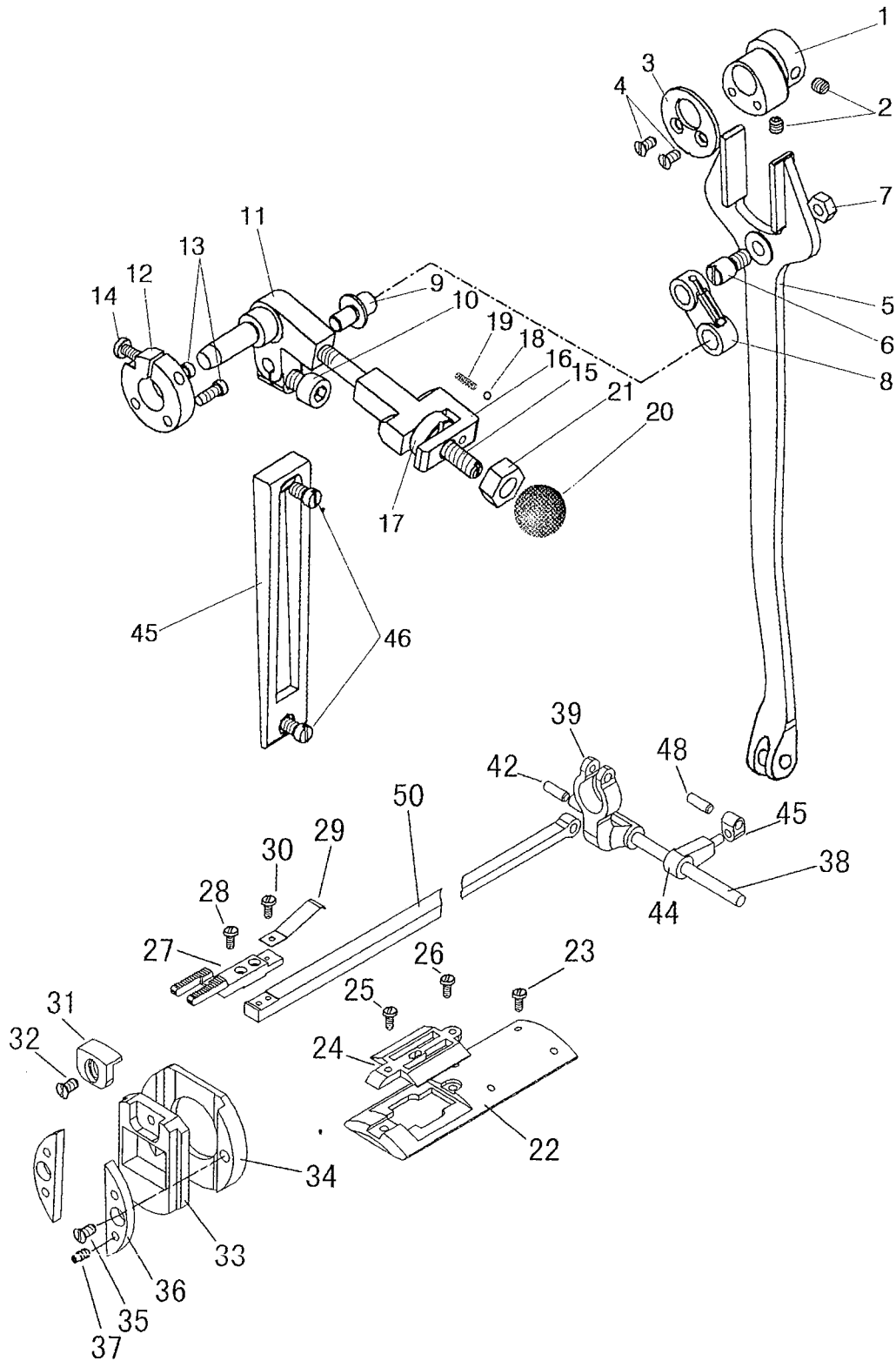



## D. FEEDING MECHANISM

Fig. No.	Part No.	Description	Pcs.	Remarks
D01	H7205E8001	Feed cam	1	
D02	H7206E8001	Set Screw	2	SM15/64(28) × 6
D03	H7207E8001	Feed cam cover	1	
D04	H2000B2050	Screw	2	SM11/64(40) × 9
D05	HD619E8001	Feed forked connection	1	
D06	H7209E8001	Feed forked connection crank pin	1	
D07	H2010J0066	Nut	1	SM9/32(28)
D08	H7210E8001	Stitch length connecting link	1	
D09	H7211E8001	Stitch length connecting link crank pin	1	
D10	H415050140	Screw	1	M5 × 14
D11	H7212E8001	Stitch length adjusting pin	1	
D12	H7213E8001	Damping plate	1	
D13	HA104G0012	Screw	2	SM3/16(28) × 12
D14	H7211D8001	Screw	1	SM3/16(32) × 18
D15	H7214E8001	Stitch length adjusting bolt	1	
D16	H7215E8001	Stitch length limited plate	1	
D17	H7216E8001	Nut	1	
D18	HE00001032	Metal ball	1	
D19	H7217E8001	Spring	1	
D20		Plastic ball	1	M8 × 32 (black)
D21	H003008080	Nut	1	M8
D22	HD605E8001	Needle plate splint	1	
D23	HA104G0012	Screw	4	
D24	HD606E8001	Needle plate	1	
D25	H2204C0651	Screw (long)	1	
D26	HD623E8001	Screw (short)	1	
D27	HD607E8001	Feed dog	1	
D28	H4006I0673	Screw	2	
D29	HD608E8001	Feed dog spring	1	
D30	HA104C0659	Screw	1	
D31	HD609E8001	Adjusting board	1	
D32	H5711G8001	Screw	1	
D33	HD610E8001	Slide block	1	
D34	HD612E8001	Slide block base	1	
D35	HA104G0012	Screw	2	
D36	HD613E8001	Pressure plate	2	
D37	HA104G0654	Screw	4	
D38	HD614E8001	Feed driving shaft	1	
D39	HD615E8001	Feed driving arm	1	
D42	HD616E8001	Hinge	1	
D44	HD617E8001	Feed shaft arm	1	
D45	HD618E8001	Feed shaft arm connection	1	
D48	HD616E8001	Hinge	1	

# D. FEEDING MECHANISM

Fig. No.	Part No.	Description	Pcs.	Remarks
D50	HD620E8001	Feed driving connecting link	1	
D51	HD621E8001	Stitch length indicating plate	1	
D52	HA104F0654	Screw	2	SM15/64(28) × 9

# E. UPPER SHAFT & PRESSER FOOT MECHANISM

---

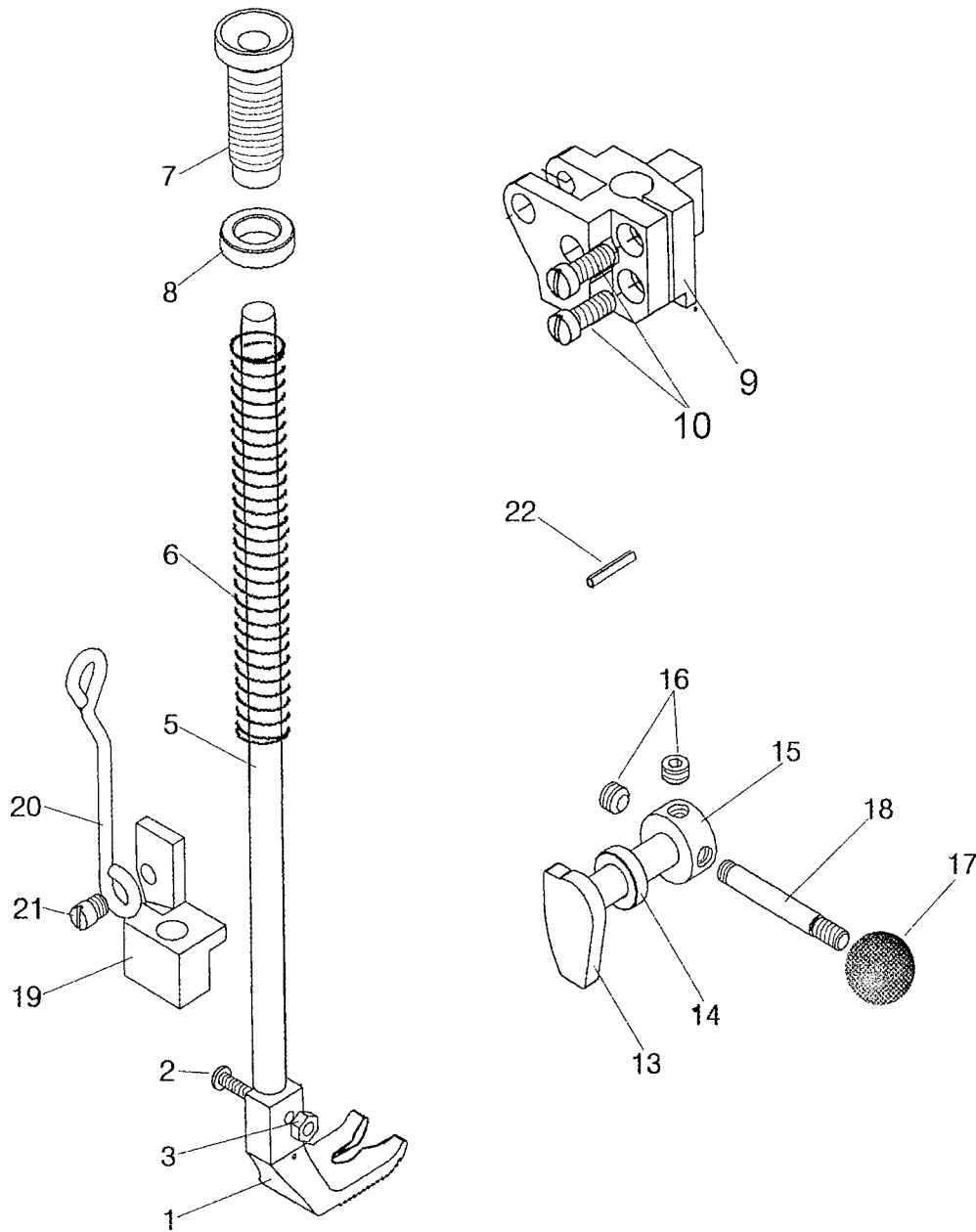

# E. UPPER SHAFT & PRESSER FOOT MECHANISM

Fig. No.	Part No.	Description	Pcs.	Remarks
E01	HD604F8001	Presser foot	1	
E02	H7205F8001	Screw	1	SM9/64 (40) × 14
E03	HA710P0673	Nut	1	SM9/64 (40)
E05	H7207F8001	Presser bar	1	
E06	H7208F8001	Presser bar spring	1	
E07	H7209F8001	Thumb screw	1	SM5/8 (28)
E08	H7210F8001	Nut	1	SM5/8 (28)
E09	H7216G8001	Presser bar guide bracket	1	
E10	HA104G0012	Screw	2	SM3/16" (4.76) × 28/12
E13	H7214F8001	Presser bar lifting shaft	1	
E14	H7215F8001	Washer	1	
E15	H7217F8001	Collar	1	
E16	H7218C8001	Set Screw	2	SM1/4 (40) × 4.5
E17		Plastic ball	1	M6 × 20
E18	H7219F8001	Bolt	1	
E19	H7220F8001	Presser bar guide bracket	1	
E20	H7221F8001	Connecting rod	1	
E21	H7222F8001	Screw	1	SM1/4 (40)
E22	H609030180	Pin	1	

# F. KNEE LOFTER MECHANISM

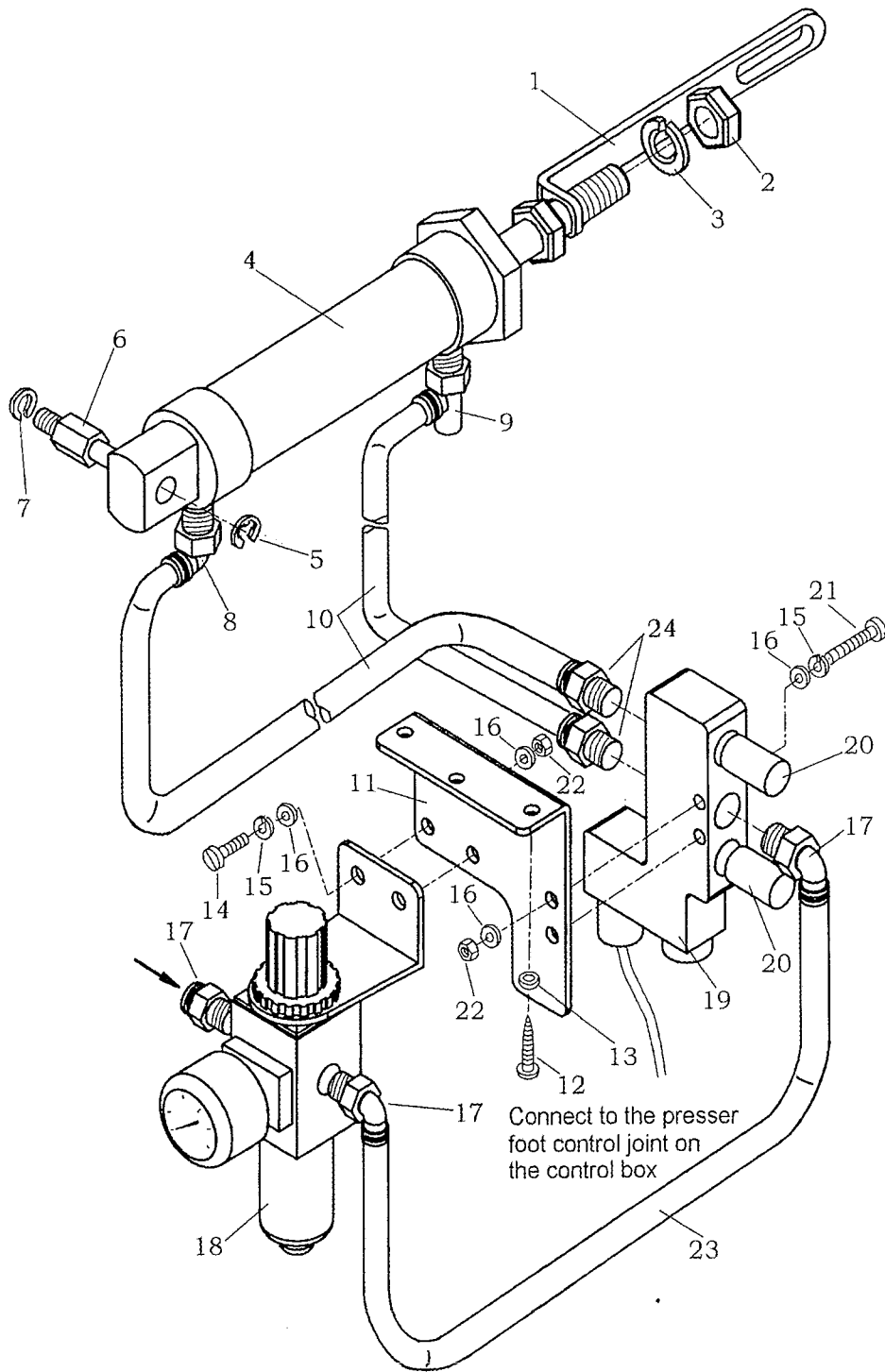

# F. KNEE LOFTER MECHANISM

Fig. No.	Part No.	Description	Pcs.	Remarks
F01	H8906I8001	Cylinder bar	1	
F02		Nut	1	M10×1.25
F03	H005008100	Spring Washer	1	
F04	H4910N8001	Cylinder	1	MAL25×50
F05	H007013060	E type ring	1	
F06	H8907I8001	Swing Pin	1	
F07	H005008080	Spring Washer	1	
F08	H4921N8001	Tube Fitting	1	φ 6-1/8"
F09	H4922N8001	Timing valve	1	φ 6-1/8"
F10	H8908I8001	PU Tube	2	φ 6 (1.6m)
F11	H4923N8001	Bracket for filtration and decompression	1	
F12	H801045200	Screw	2	M4.5×20
F13	HA300J2230	Washer	2	
F14	H402040120	Screw	2	M4×12
F15	H005008040	Spring washer	4	
F16	H005005040	Washer	8	
F17	H8909I8001	Tube Fitting	3	φ 8-1/4"
F18	H4915N8001	Valve for filtration and decompression	1	
F19	H4918N8001	Solenoid Valve	1	
F20	H4924N8001	Silencer	2	
F21	H402040300	Screw	2	M4×30
F22	H003002040	Nut	4	M4
F23	H8910I8001	PU Tube	1	φ 8 (0.2m)
F24	H4917N8001	Tube Fitting	2	φ 6-1/4"

# G. BOBBIN WINDER MECHANISM

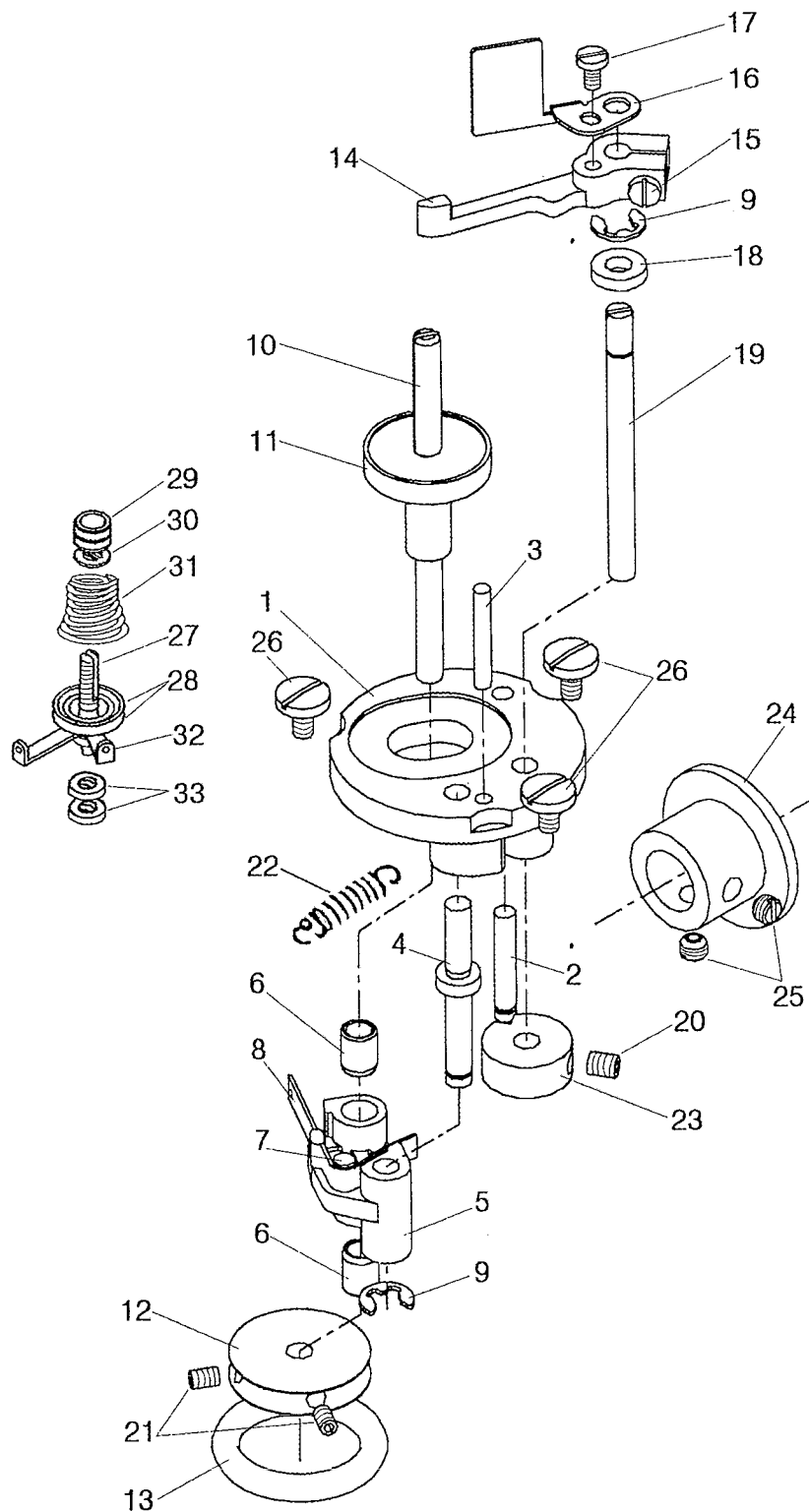

# G. BOBBIN WINDER MECHANISM

Fig. No.	Part No.	Description	Pcs.	Remarks
G01	H6706N8001	Bobbin winder plate	1	
G02	H6707N8001	Pin	1	
G03	H6708N8001	Pin	1	
G04	H7210J8001	Bobbin winder crank shaft	1	
G05	H7213J8001	Bobbin winder crank	1	
G06	H6713N8001	Bushing	2	
G07	H6714N8001	Pin	1	
G08	H6715N8001	Bobbin winder spring	1	
G09	H007013050	Retaining ring-E type	2	
G10	H7205J8001	Bobbin winder shaft	1	
G11	H6717N8001	Bobbin base	1	
G12	H6718N8001	Driven wheel	1	
G13	H6719N8001	Friction rubber band	1	
G14	H6720N8001	Bobbin winder lever	1	
G15	HA100H2150	Screw	1	SM9/64(40) × 11
G16	H7206J8001	Winding length limited plate	1	
G17	H3200B2100	Screw	1	
G18	H6722N8001	Washer	1	
G19	H6723N8001	Pin	1	
G20	H6731N8001	Set Screw	1	M5 × 6
G21	H6732N8001	Set Screw	2	M3 × 4
G22	H6724N8001	Spring	1	
G23	H6725N8001	Bobbin winder cam	1	
G24	H7005D8001	Driving wheel	1	
G25	H4723D8001	Set Screw	2	SM15/64(28)
G26	H3107G0662	Screw	3	SM11/64(40)
G27	H7208J8001	Screw	1	
G28	HA310B0705	Tension disc	2	
G29	HA115B0702	Nut	1	
G30	HA115B7010	Limited plate	1	
G31	H3300B2040	Spring	1	
G32	H6662B8001	Thread guide	1	
G33	H003008040	Nut	2	M4



H. ACCESSORIES-1

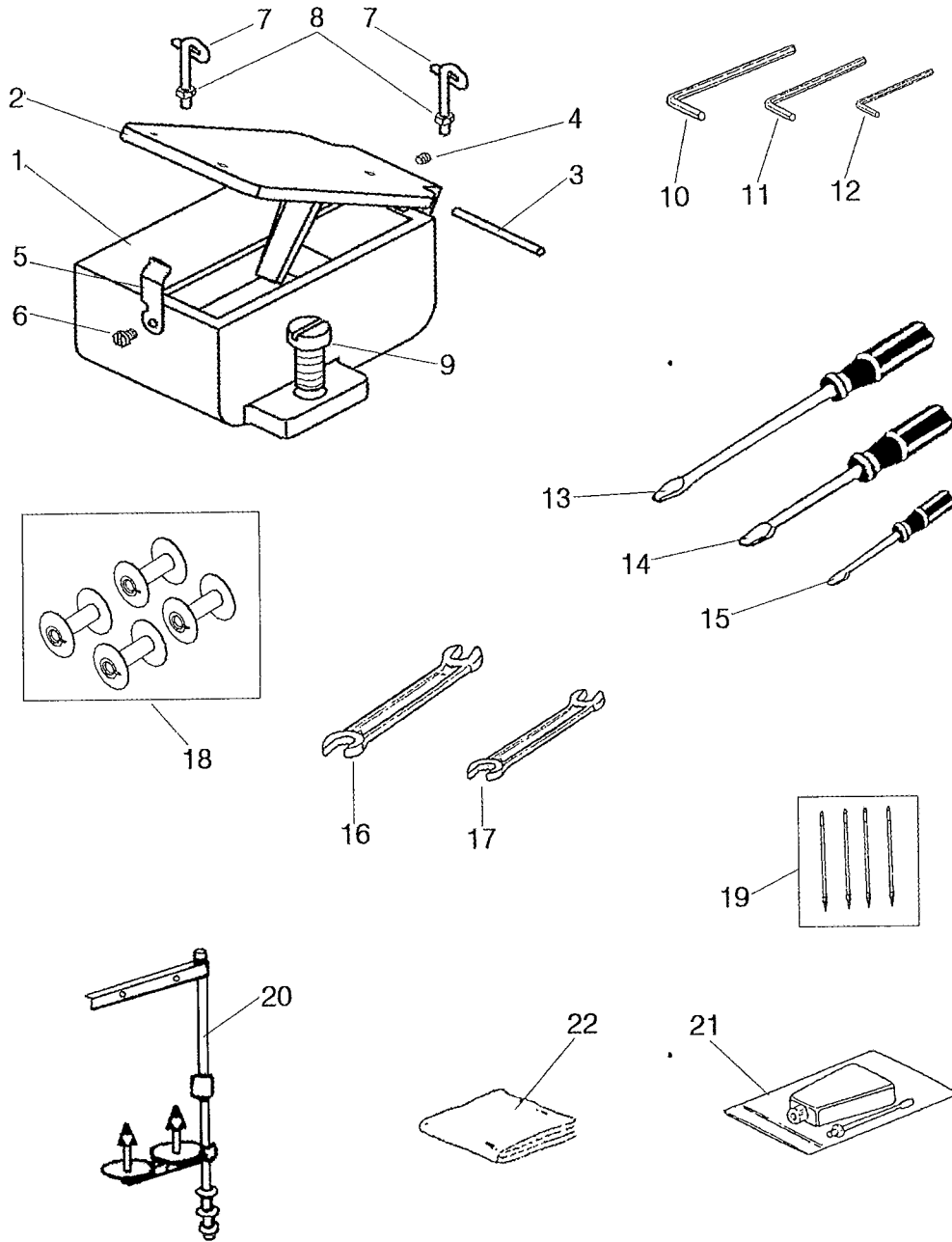

H. ACCESSORIES-1

Fig. No.	Part No.	Description	Pcs.	Remarks
H01	H7207K8001	Silicon oil box	1	
H02	H7208K8001	Cover	1	
H03	H605030400	Pin	1	
H04	H34411C410	Screw	1	SM9/64 (40) × 4
H05	H7209K8001	Spring	1	
H06	H3215K0693	Screw	1	SM9/64 (40) × 5
H07	H7210K8001	Thread guide	2	
H08	H7211K8001	Nut	2	SM3/32 (56)
H09	HA800F2020	Screw	1	SM15/64 (28)
H10	HB00001050	Hexagon socket screw key	1	
H11	HB00001040	Hexagon socket screw key	1	
H12	HB00001030	Hexagon socket screw key	1	
H13	HA300J2070	Screw driver (size L)	1	
H14	HA300J2200	Screw driver (size M)	1	
H15	HA300J2210	Screw driver (size S)	1	
H16	HJ02090110	Spanner	1	
H17	HJ02100130	Spanner	1	
H18	H7228D8001	Bobbin	4	
H19	H7220C8001	Needle	4	
H20	HA200J2030	Thread stand assy	1	
H21	H200400069	Oiler	1	
H22	H8904K8001	Vinyl cover	1	

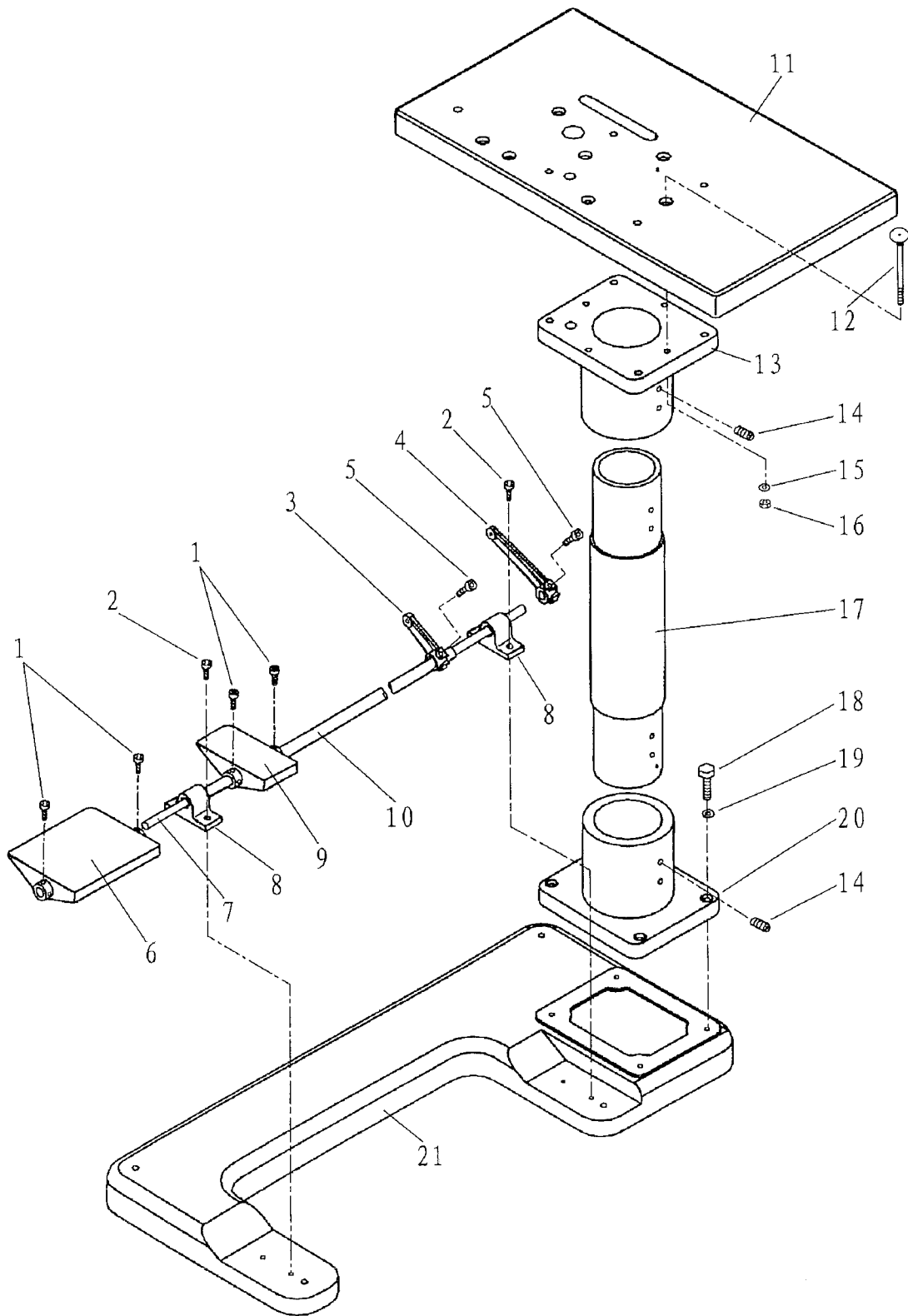

I. ACCESSORIES-2

Fig. No.	Part No.	Description	Pcs.	Remarks
I01	H415060140	Screw	8	M6×14
I02	H103080250	Screw	4	M8×25
I03	H8918K8001	Short rod	1	
I04	H8917K8001	Long rod	1	
I05	H415080160	Screw	4	M8×16
I06	H8924K7101	Large pedal	1	
I07	H8920K8001	Long steel tube	1	
I08	H8913K8001	Steel tube base	2	
I09	H8924K7101	Small pedal	1	
I10	H8918K8001	Short steel tube	1	
I11	H8910K8001	Bedplate	1	
I12	H125100900	Screw	4	M10×90
I13	H8915K8001	Flange	1	
I14	H429120250	Set Screw	4	M12×25
I15	H005001100	Washer	4	
I16	H003002100	Nut	4	M10
I17	H8912K8001	Connecting steel tube	1	
I18	H103120500	Screw	4	M12×50
I19	H005008120	Spring washer	4	
I20	H8916K8001	Flange	1	
I21	H8911K8001	Operation base	1	



**SHANGHAI HUIGONG NO.3 SEWING MACHINE FACTORY**

**ADD: 1418, Yishan Road, Shanghai, China**

**Zip Code: 201103**

**Overseas Business: TEL: 86-21-64853303 FAX: 86-21-64854304**

**E-mail: [highlead@online.sh.cn](mailto:highlead@online.sh.cn) <http://www.highlead.com.cn>**

The description covered in this manual is subject to change for improvement of the commodity without notice

2007.2. Printed