

**Auto- Sharpening
Cutting Machine**

自动磨刀裁剪机

**Instruction Manual
And Parts List**

使用手册
零件目录

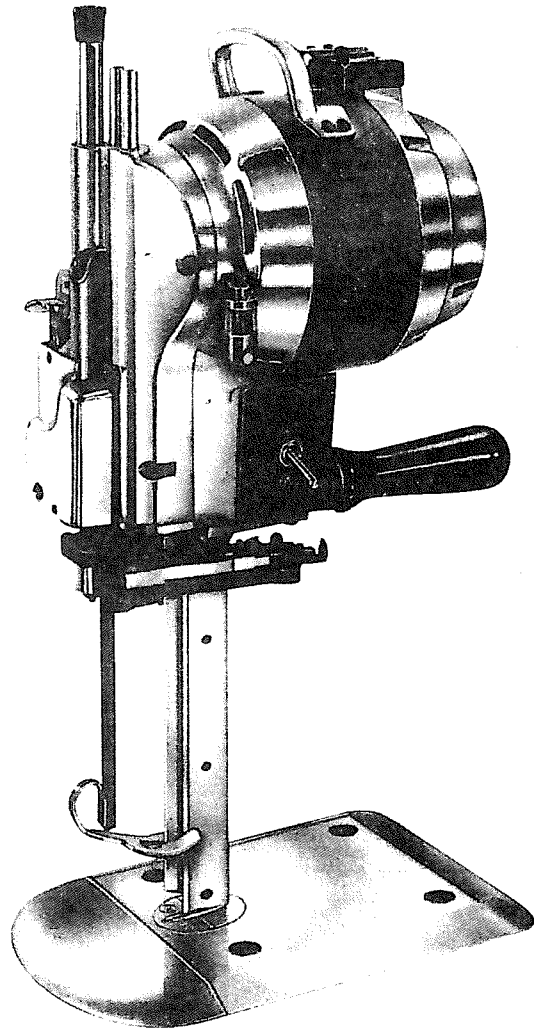
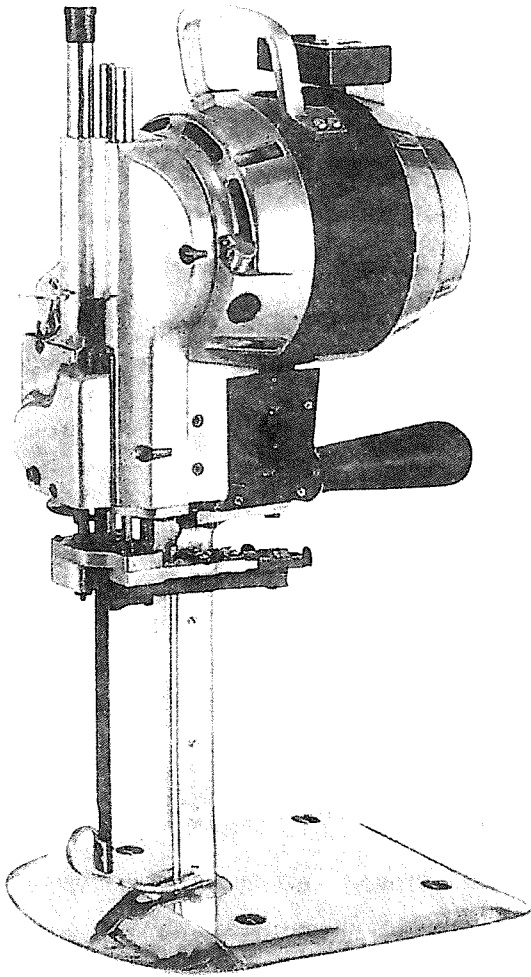

MODEL CZM200

使用，和加油 和维护

使用前请仔细阅读

使用前

应向油杯内加油；将电机后的旋钮推入转几转，刀片应能上下灵活移动。

—— 注意 ——

当心刀片快口伤人。操作时请使用木手柄推动机器，搬动机器时，请使用提手柄

维护

(1)每星期两次用风管或风箱把马达和磨刀器上的绒头吹掉。(2)每星期一次取下前盖将丝杆上的绒头弄干净。(3)每天至少一次取下刀片，用槽子清洗器刀槽清理干净。(4)请勿向底板滚轮加油。(5)若轮子滚不动，请拆下清洗。

—— 注意 ——

未装刀片时切勿磨刀，以免造成机器损坏。

请放下压脚，用力慢慢地按下磨刀手柄。如果轧死，请抬起拨叉，从新再来几次后，你便会知道怎样的轻重最适合。

Operation, Lubrication and care

Before operating machine, read this page carefully.

Before operating the motor, be sure that electric supply voltage and current are the same as stamped on the nameplate.

Fill oil cup. Push in turning knob and turn the machine over a few revolutions by hand to see if the knife moves easily.

WARNING

This machine is equipped with a sharp knife. Keep hands away from the knife area at all times. Use control levers and handles only when operating or handling machine.

CARE OF MACHINE

Use air hose or bellows with proper eye shields and blow lint out of motor and sharpener twice a week. Remove cover over cam and clean out lint around screw mechanism in sharpener once a week. Remove knife and clean slides with slot cleaner at least once a day. To prevent undue accumulation of lint, do not oil plate rollers. If rollers stick, remove from plate and wash in cleaning solvent.

WARNING

Do not operate sharpener without knife in machine or the sharpener will be damaged.

TO SHARPEN THE KNIFE

Take the machine out of the lay. Drop pressure foot by means of pressure foot lever located next to machine operating handle. Press release lever downward with a slow, firm pressure to engage sharpening mechanism. Too fast lever action may cause lever to lock. If this occurs, lift latch lever and start over. After a few tries you will feel correct operating pressure.

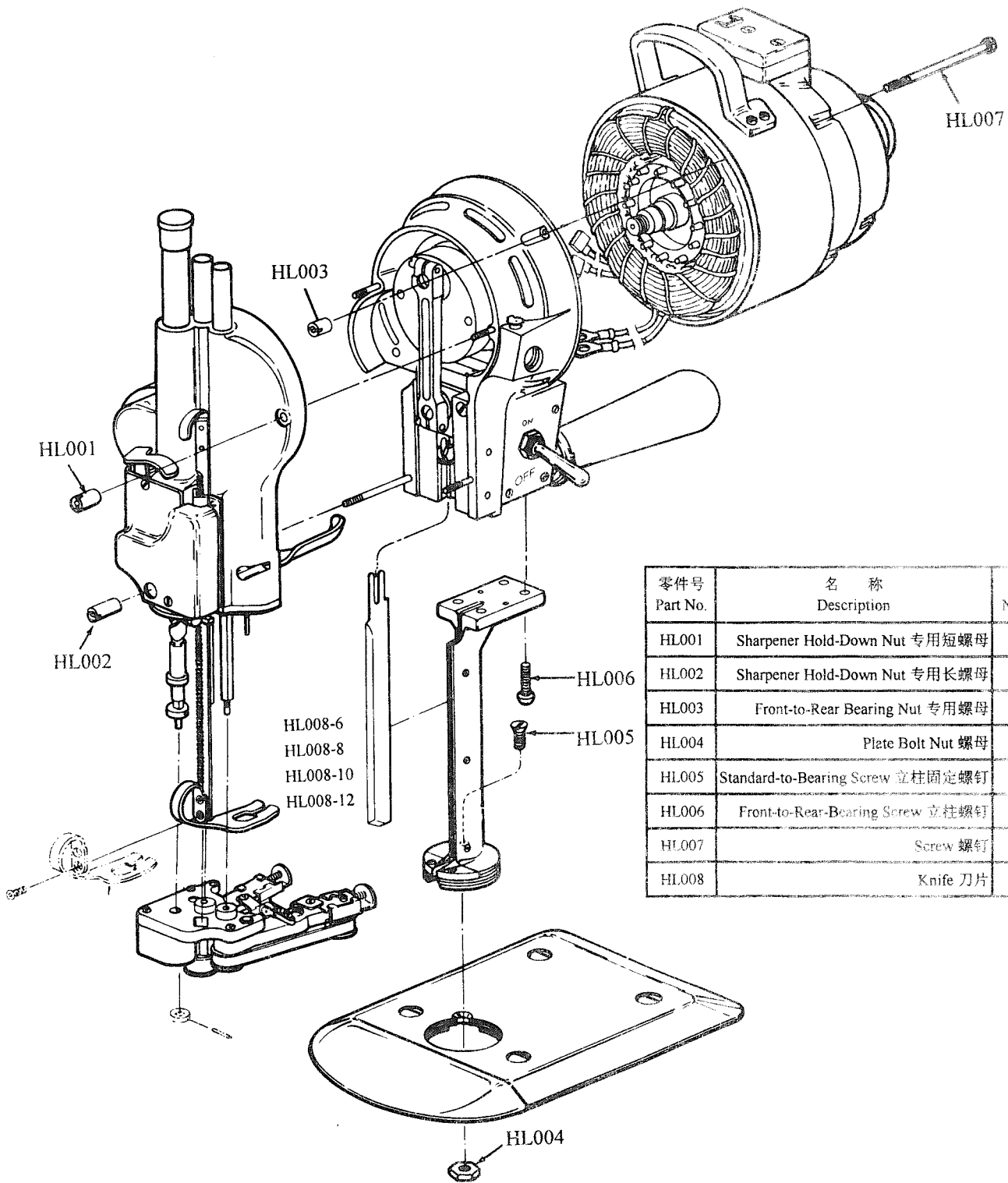

零件号 Part No.	名称 Description	数量 No. Req'd
HL001	Sharpener Hold-Down Nut 专用短螺母	3
HL002	Sharpener Hold-Down Nut 专用长螺母	1
HL003	Front-to-Rear Bearing Nut 专用螺母	4
HL004	Plate Bolt Nut 螺母	1
HL005	Standard-to-Bearing Screw 立柱固定螺钉	1
HL006	Front-to-Rear-Bearing Screw 立柱螺钉	4
HL007	Screw 螺钉	4
HL008	Knife 刀片	1

单相马达组

Single-Phase Motor Assemblies

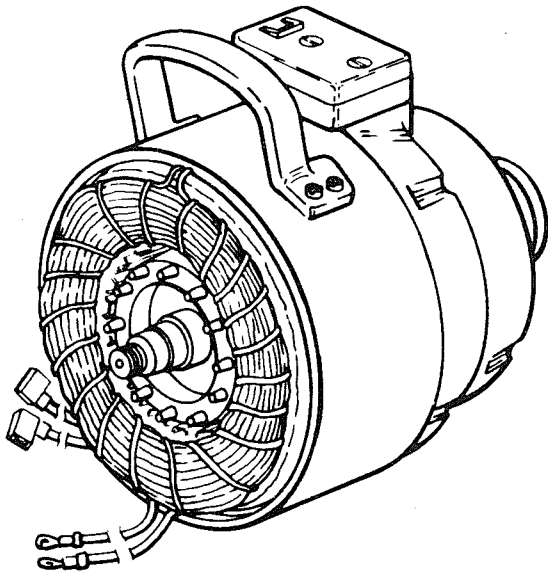

零件号 Part No.	名称 Description	数量 No. Req'd
HL009	Terminal Wire Tubing 绝缘器	1
HL010	Stator with Band 电机定子组件	1
HL011	Rotor and Shaft 电机转子组件	1
HL012	Carrying Handle 提手柄	1
HL013	Screw 提手柄螺钉	4
HL014	Terminal Wire Tubing 引线管	1
HL015	Rear Ball Bearing 单列向心球轴承	2
HL016	Terminal 线耳	2
HL017	Rear Bearing House 后机匣	1
HL018	Terminal Block 插头组件	1
HL019	Attachment Plug 电源插头组件	1
HL020	Screw 插头组件螺钉	2
HL021	Cutout Switch Mount 离心开关罩	1
HL022	Automatic Cutout 离心开关切断器	1
HL023	Automatic Cutout Switch 离心开关组件	1
HL024	Shaft Cover For Cutout 离心开关轴套	1
HL025	Screw 离心开关罩螺钉	2
HL026	Screw 离心开关盖螺钉	2
HL027	Cover for Cutout 离心开关盖	1
HL028	Rotor Fan 风轮	1
HL029	Leading Spring Washer 止动垫圈	1
HL030	Clutch Nut 电机转子圈	1
HL031	Retaining Ring 轴用弹性挡圈	1
HL032	Fan Cover 风轮盖	1
HL033	Screw 风轮盖螺钉	2
HL034	Clutch Spring 弹簧	1
HL035	Turning Knob 旋钮	1

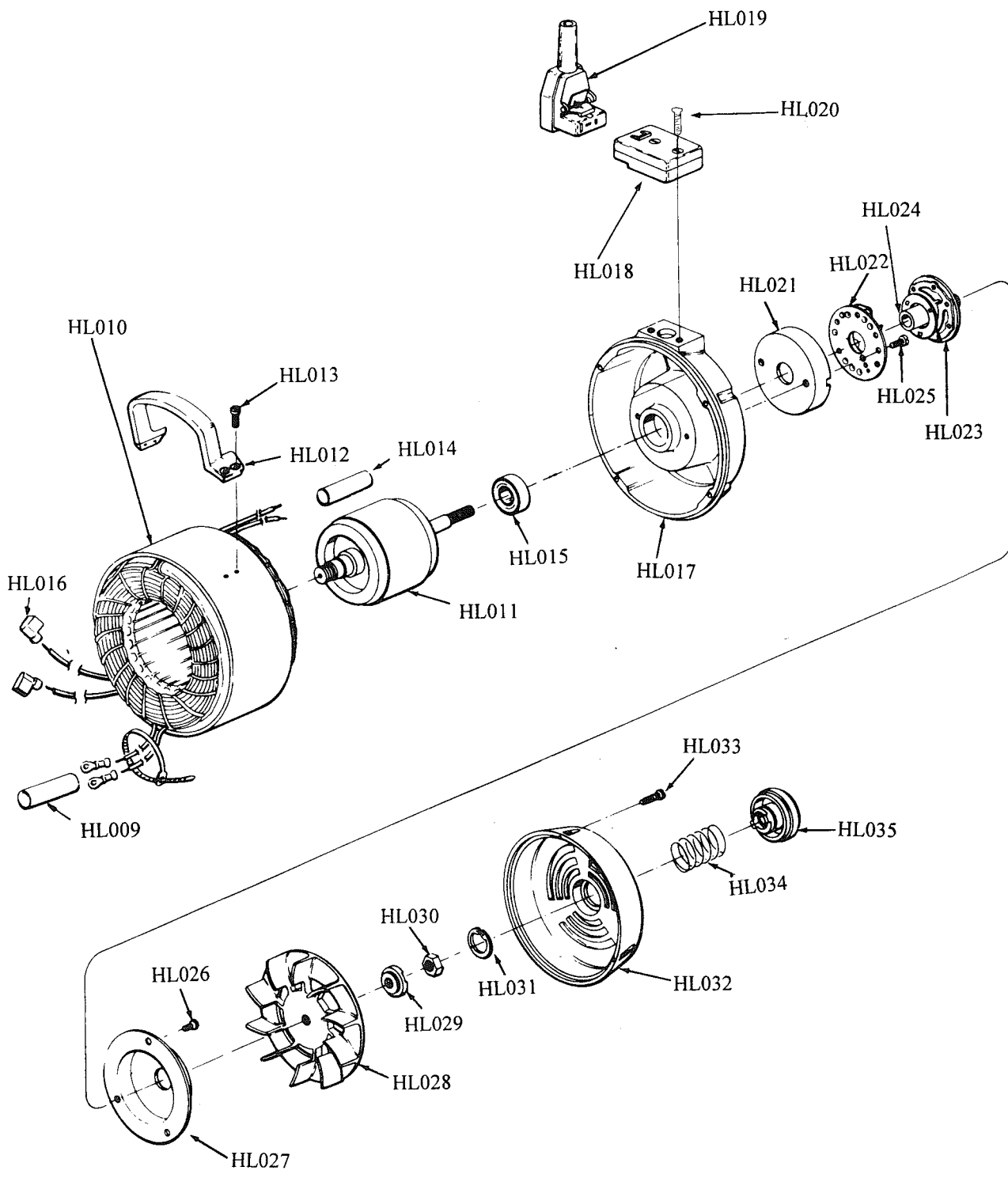

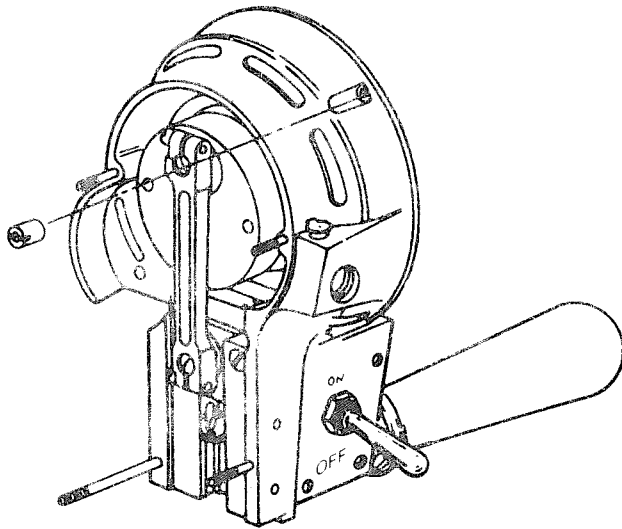

前轴承套组

Front Bearing Housing Assembly

零件号 Part No.	名称 Description	数量 No. Req'd
HL036	Screw 电容器罩螺钉	6
HL037	Screw 电容压板螺钉	1
HL038	Capacitor Cover 电容器罩	1
HL039	Capacitor 启动电容	1
HL040	Cover for Capacitor 电容器外套	1
HL041	Spring for Capacitor 电容压板	1
HL042	Shaft Lock Nut 六角螺母	1

零件号 Part No.	名称 Description	数量 No. Req'd
HL043	Front Bearing Housing 前机匣	1
HL044	Bearing 单列向心球轴承	1
HL045	Front Ball Bearing Retainer 前机匣轴承挡圈	1
HL046	Screw 轴承挡圈螺钉	4
HL047	Screw 内六角平端紧定螺钉	3
HL048	Washer 垫圈	9
HL049	Nut 螺母	3
HL050	Crank 偏心轮	1
HL051	Stud. Upper 双头螺栓	2
HL052	Stud. Lower Mounting 双头螺栓	1
HL053	Stud. Lower Mounting 双头螺栓	1
HL054	Guide Adjustment Nut 支撑螺套	3
HL055	Shaft for Ball Bearing 传动销	1
HL056	Seated Crank Ball Bearing 单列向心球轴承	1
HL057	Lock Nut for Shaft 传动销螺母	1
HL058	Crank Ball Bearing Lock Nut 轴承挡圈	1
HL059	Connecting Rod 连杆	1
HL060	Screw 连杆螺钉	2
HL061	H. Guide 导轨	1
HL062	Cross Head 中心滑块	1
HL063	Wrist Pin 从动销	1
HL064	Wrist Pin Felt Pad 油绳	1
HL065	Connecting Rod Washer 垫片	1
HL066	Screw 半端紧定螺钉	1
HL067	Guide Washer 垫片	1
HL068	Screw 圆柱头内六角螺钉	6
HL069	Knife Lock Washer 固定刀垫片	1
HL070	Screw 方头螺钉	1
HL071	Screw 圆柱头内六角螺钉	2
HL072	Handle Bracket 力板	1
HL073	Screw 内六角螺钉	1
HL074	Screw for Handle Bracket 力板螺钉	1
HL075	Operating Handle Lock Nut 木手柄锁紧螺母	1
HL076	Operating Handle 木手柄	1
HL077	Switch 电机开关	1
HL078	Switch base 开关盖	1
HL079	Screw 开关盖螺钉	3
HL080	Oiling Device 油杯组件	1
HL081	Oil Tube 油杯座	1
HL082	Eyelet 空心铆钉	1
HL083	Cover for Oil Tube 油杯座盖板	1
HL084	Long Wicking 油绳	3
HL085	Screw 油杯座盖板螺钉	4
HL086	Screw 油杯座螺钉	2
HL087	Circle 密封圈	2
HL088	Windows for Oil 油窗	1
HL089	Oil Tube Cover 油杯座盖	1
HL090	Oil Hole Cover 油杯	1

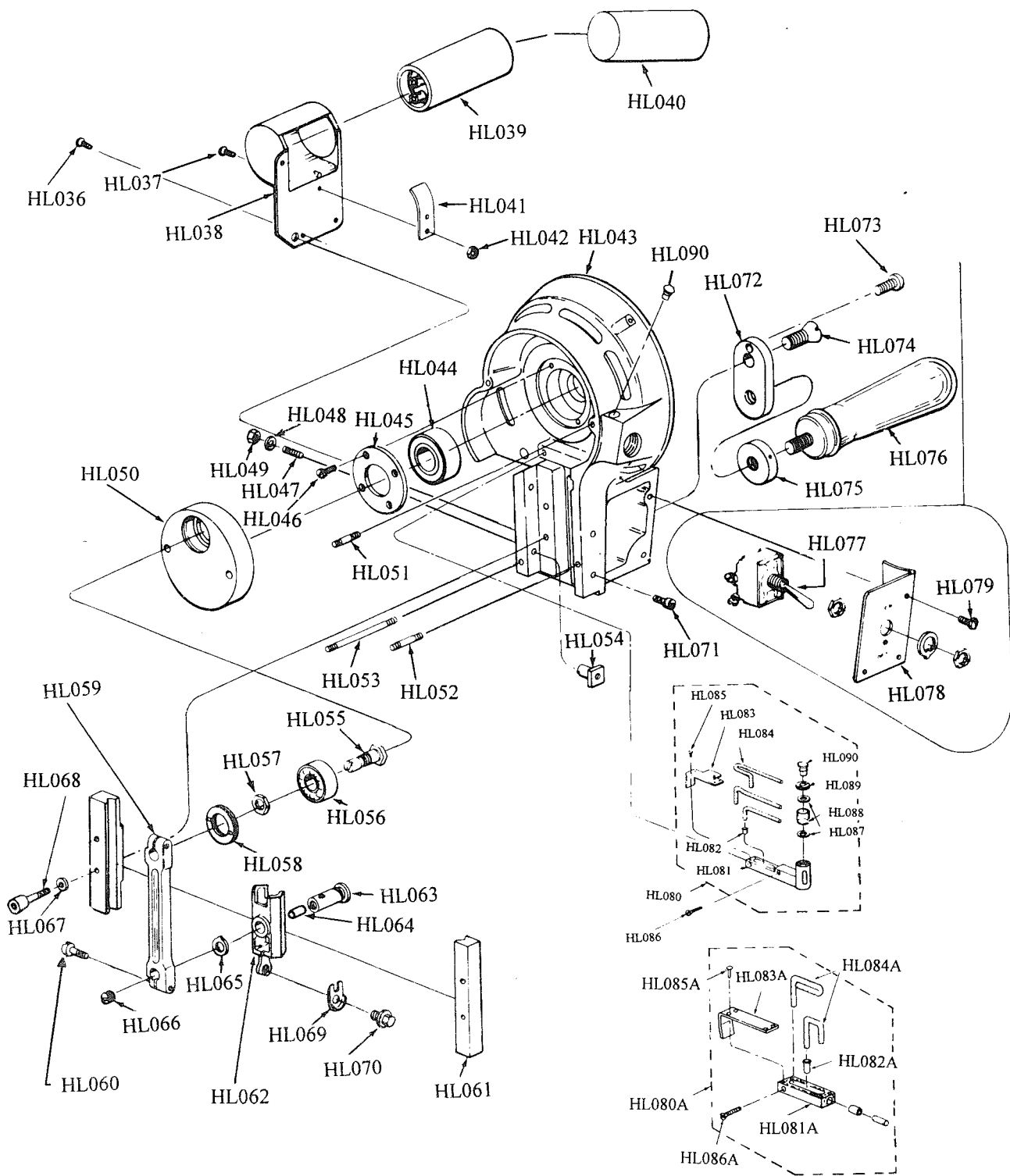

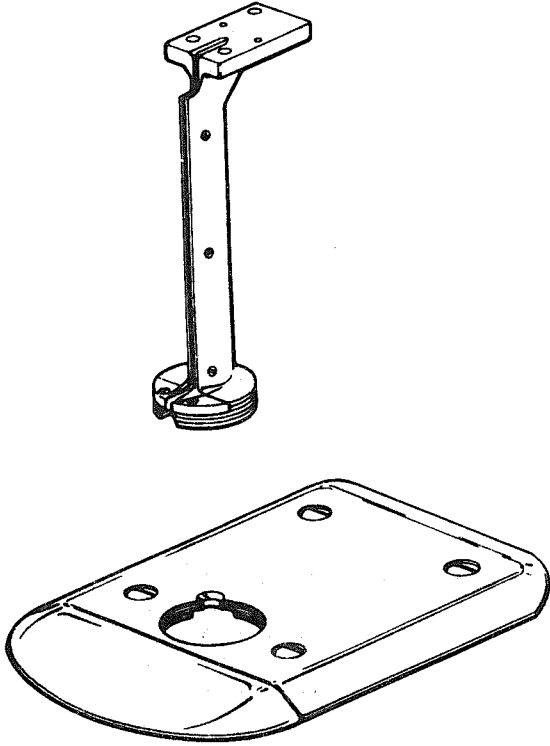

零件号 Part No.	名称 Description	数量 No. Req'd
HL091	Standard 立柱	1
HL092	Knife Slide 刀壳组件	1
HL093	Throat Plates 脚板	2
HL094	Taper Pin 脚板定位销	2
HL095	Screw 脚板螺钉	2
HL096	Screw 刀壳螺钉	3
HL097	Plate Wing 导板	1
HL098	Plate 底座	1
HL099	Rubber Roller All Set 滚轮组件	4
HL100	Roller Shell 滚轮衬套组件	4
HL101	Rubber Mounted Roller 橡胶安装座组件	4
HL102	Clamp Screw for Roller 底板压轴螺钉	12
HL103	Hinge Pin 导板连接轴	2
HL104	Plate Wing Spring 导板弹簧	2
HL105	Lock Washer #8 止动垫片	2

刀夹底盘组

Standard and Baseplate Assembly

HL091-6"
HL091-8"
HL091-10"
HL091-12"

HL092-6"
HL092-8"
HL092-10"
HL092-12"

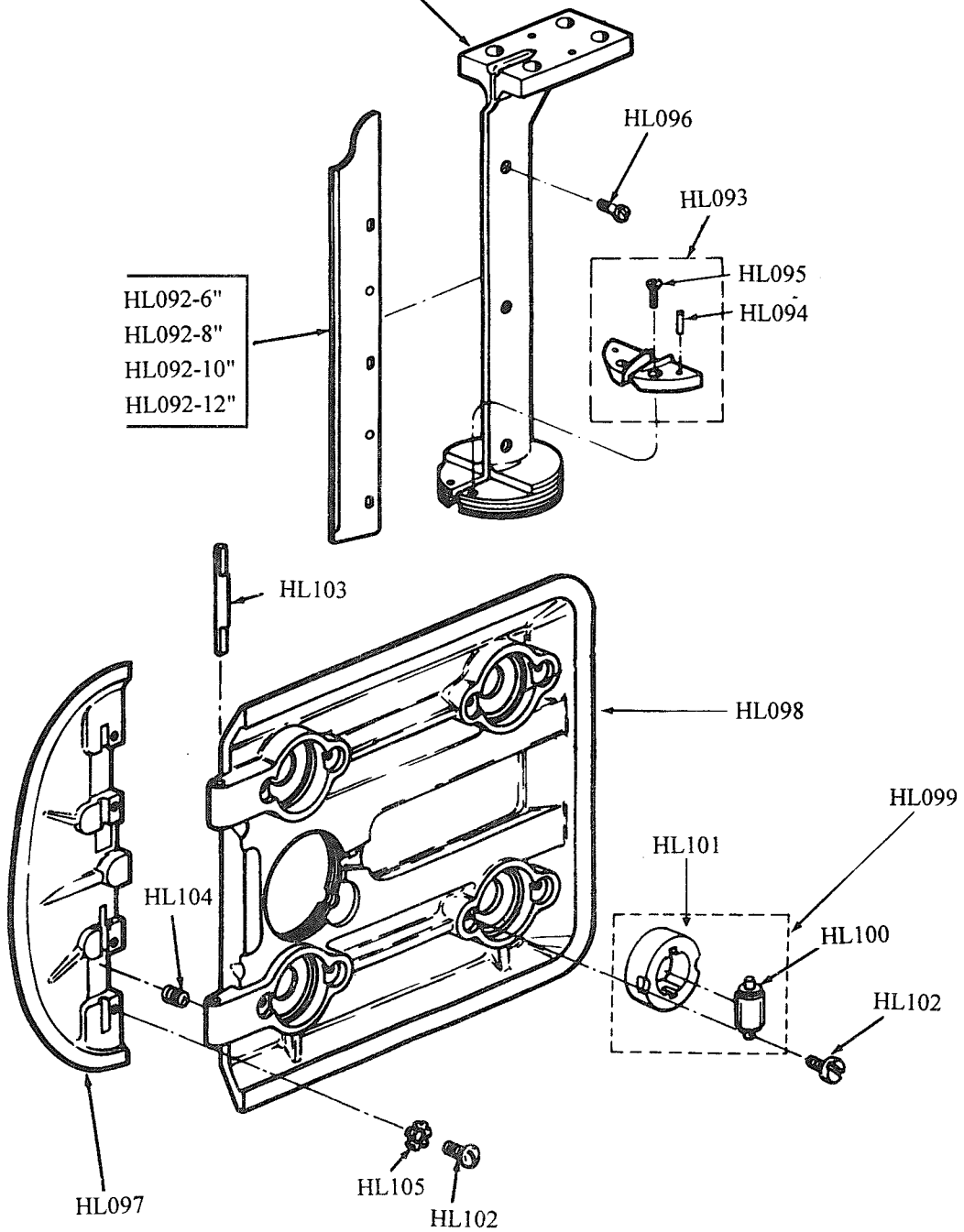

磨刀器组

背面 FRONT

Front Sharpener Housing Assembly

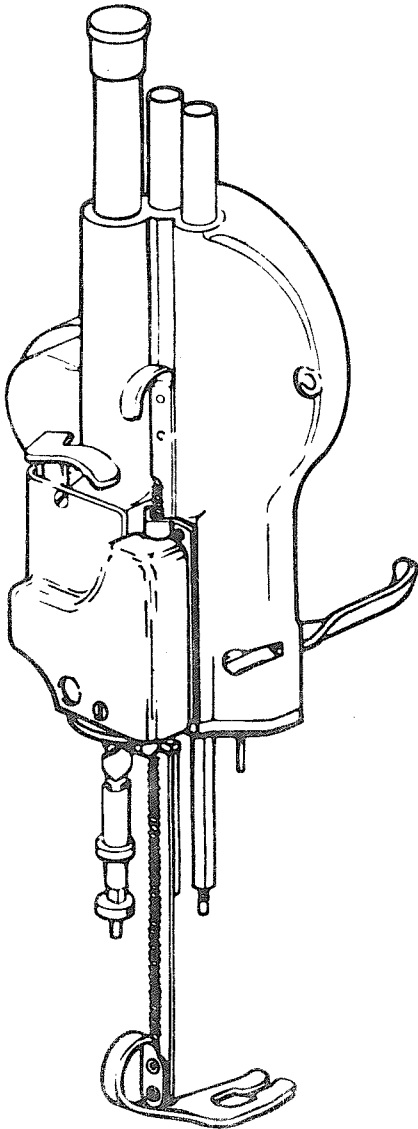

零件号 Part No.	名称 Description	数量 No.Req'd
HL106	Cap of Tube 塑料帽	1
HL107	Stop Nut for Screw Shaft 锁紧螺母	1
HL108	Nut for Screw Shaft 丝杆上螺母	1
HL109	Thrust Washer for Nuts 轴承片	3
HL110	Thrust Ball Bearing 轴承组件	3
HL111	L.H.Nut for Screw Shaft 左向螺母	1
HL112	R.H.Nut for Screw Shaft 右向螺母	1
HL113	Screw Shaft 双向丝杆	1
HL114	Collar for Extension 双向丝杆挡圈	1
HL115	Release Lever with Cam 磨刀手柄组件	1
HL116	Sharpener Housing(with Bushings and Tubes) 磨刀机匣组件	1
HL117	Spring Washer for Release Lever 弹性垫圈	1
HL118	Release Lever with Cam 磨刀手柄	1
HL119	Cam 偏心块	1
HL120	Screw 磨刀手柄铆钉	1
HL121	Set Screw for Cam 圆柱端紧定螺母	1
HL122	Screw for Release Lever 磨刀手柄活动螺钉	1
HL123	Latch for Cam 拨叉	1
HL124	Spring for Latch 拨叉弹簧	1
HL125	Screw for Latch 拨叉定位螺钉	1
HL126	Bearing for Cam Shaft 发条销下轴衬	1
HL127	Bearing for Cam Shaft 发条销上轴衬	1
HL128	Shaft for Cam 发条销	1
HL129	Cam Spring 锁紧发条	1
HL130	Cam shaft Spring Screw 发条销限位螺钉	1
HL131	Pressure Foot Lever 压脚放松手柄	1
HL132	Spring for Pressure Foot Lever 放松手柄弹簧	1
HL133	Pressure Foot Lever Screw 放松手柄螺钉	1
HL134	Spacer for Knife Guard Lock Bracket 扩齿托架垫片	1
HL135	Knife Guard Lock Bracket Complete 压脚托架	1
HL136	Lock for Pressure Foot 压脚定位板	1
HL137	Spring for Knife Guard Lock 护齿弹簧	1
HL138	Nut for Pressure Foot Lock 锁紧螺母	1
HL139	Knife Guard Lock Bracket Only 支持桩子	1
HL140	Screw for Knife Guard Lock 护齿螺钉	1
HL141	Screw 压脚托架螺钉	4
HL142	Pressure Foot Lock Bracket Complete 压脚托架组件	1
HL143	Cover Over Cam 前罩	1
HL144	Screw 前罩下螺钉	1
HL145	Screw 前罩上螺钉	1
HL146	Screw for Pressure Foot Shoe 压脚螺钉	2
HL147	Pressure Foot Shoe 压脚	1
HL148	Screw 压脚杆提手柄螺钉	2
HL149	Lift Handle for Knife Guard Rod 压脚杆提手柄	1
HL150	Knife Guard Rod 压脚杆	1

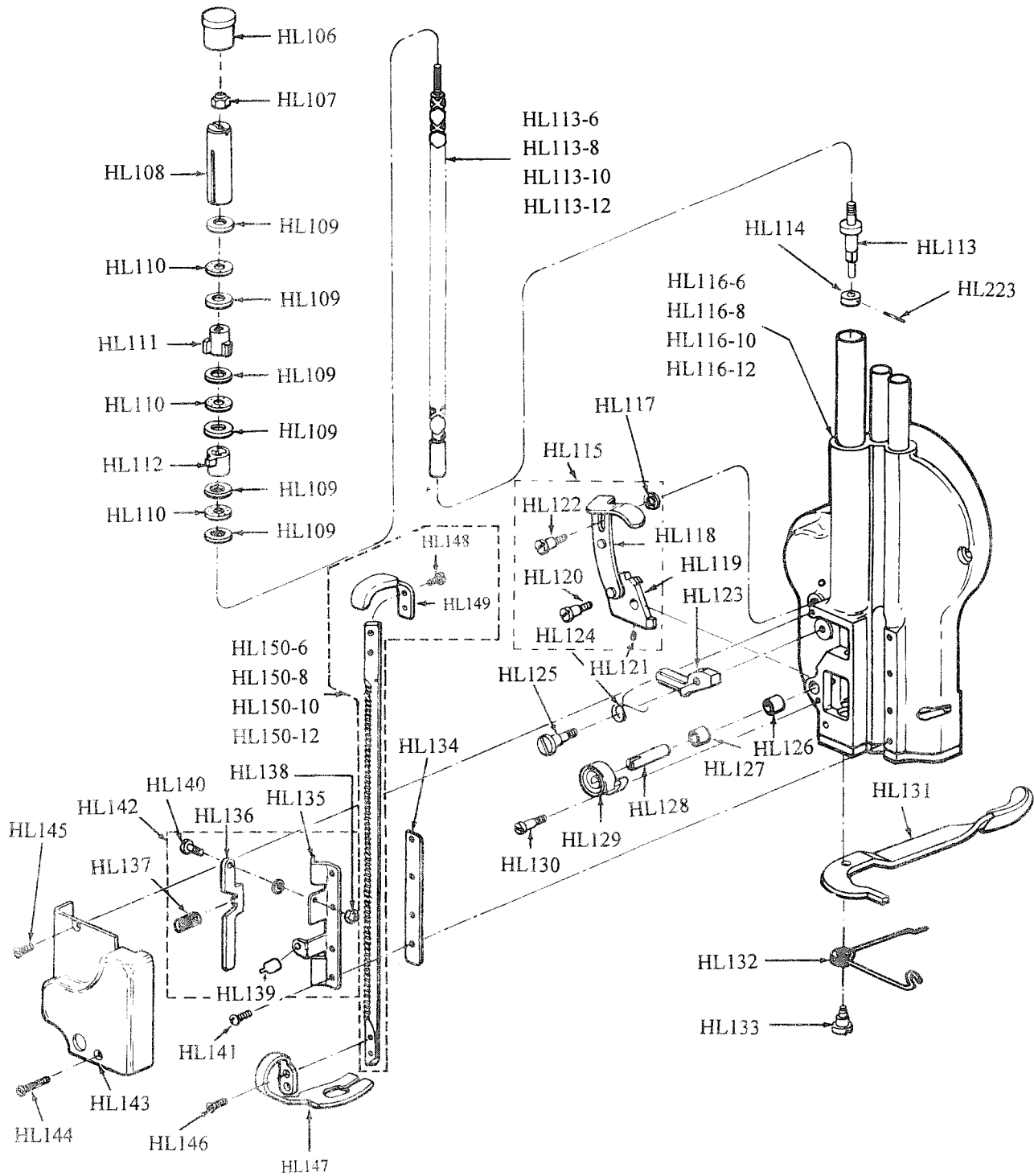

磨刀器组

背面 BACK

Front Sharpener Housing Assembly

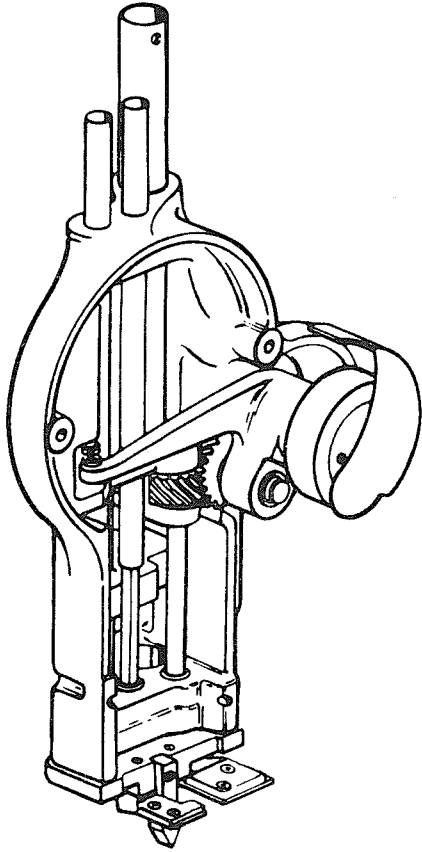

零件号 Part No.	名称 Description	数量 No. Req'd
HL151	R.H.Follower Nut 随动螺母	1
HL152	L.H.Follower Nut 随动左螺母	1
HL153	Square Shaft 方导杆	2
HL154	Tube for Square Shaft 方导杆管套	2
HL155	Tube for Screw Shaft 丝杆管套	1
HL156	Sharpener Housing 磨刀机匣	1
HL157	Felt Pad for Oil Retainer-Idler Gear 从动斜齿轮油盖毛毡	1
HL158	Oil Retainer-Idler Gear 从动斜齿轮油盖	1
HL159	Screw 斜齿轮油盖螺钉	2

零件号 Part No.	名称 Description	数量 No. Req'd
HL160	Shaft for Gear 斜齿轮芯轴	1
HL161	Idler Gear 斜齿轮	1
HL162	Gear and Shaft 斜齿轮轴	1
HL163	Bell Crank 斜齿轮传动机匣	1
HL164	Ball Bearing for Crank 单列向心球轴承	2
HL165	Spacer for Bell Bearings 斜齿轮轴衬圈	1
HL166	Retaining Ring for Bell Crank 孔用弹性挡圈	1
HL167	Drive Pulley with Driver 摩擦轮组件	1
HL168	Bearing for Bell Crank 斜齿轮芯轴衬套	1
HL169	Washer for Shaft 垫片	1
HL170	Retaining Ring for Shaft 轴用弹性挡圈	1
HL171	Pin for Bell Crank 顶针	1
HL172	Bearing for Drive Shaft 斜轮传动杆上轴衬	1
HL173	Thrust Washer 15牙斜齿轮垫圈	2
HL174	Spiral Gear 15牙斜齿轮	1
HL175	Bearing for Drive Shaft 齿轮传动杆中衬套	1
HL176	Bearing for Drive Shaft 齿轮传动杆下衬套	1
HL177	Key 键	1
HL178	Driver Shaft with Gear 齿轮传动杆	1
HL179	Lock Nut for Shaft 六角扁螺母	1
HL180	Pin for Sharpener Housing 推杆挡桩	1
HL181	Spring for Bell Crank 支撑弹簧	1
HL182	Bearing for Gears 20牙齿轮轴衬	2
HL183	Spur Gear 20牙齿轮	2
HL184	Thrust Washer for Bottom Plate 底板座垫圈	2
HL185	Push Rod 推杆	1
HL186	Roll for Push Rod 推杆定位销	1
HL187	Bearing for Screw Shaft 丝杆轴套	1
HL188	Bottom Plate 磨刀机匣底板	1
HL189	Oil Pad and Holder 油垫座	1
HL190	Spreader Pin 分隔块	1
HL191	Screw 分隔块螺钉	1
HL192	Screw 磨刀机匣底板螺钉	3
HL193	Screw 油垫座螺钉	2
HL194	Rivet 空心铜铆钉	4
HL195	H.Oil Pad 油垫座左右毡垫	1

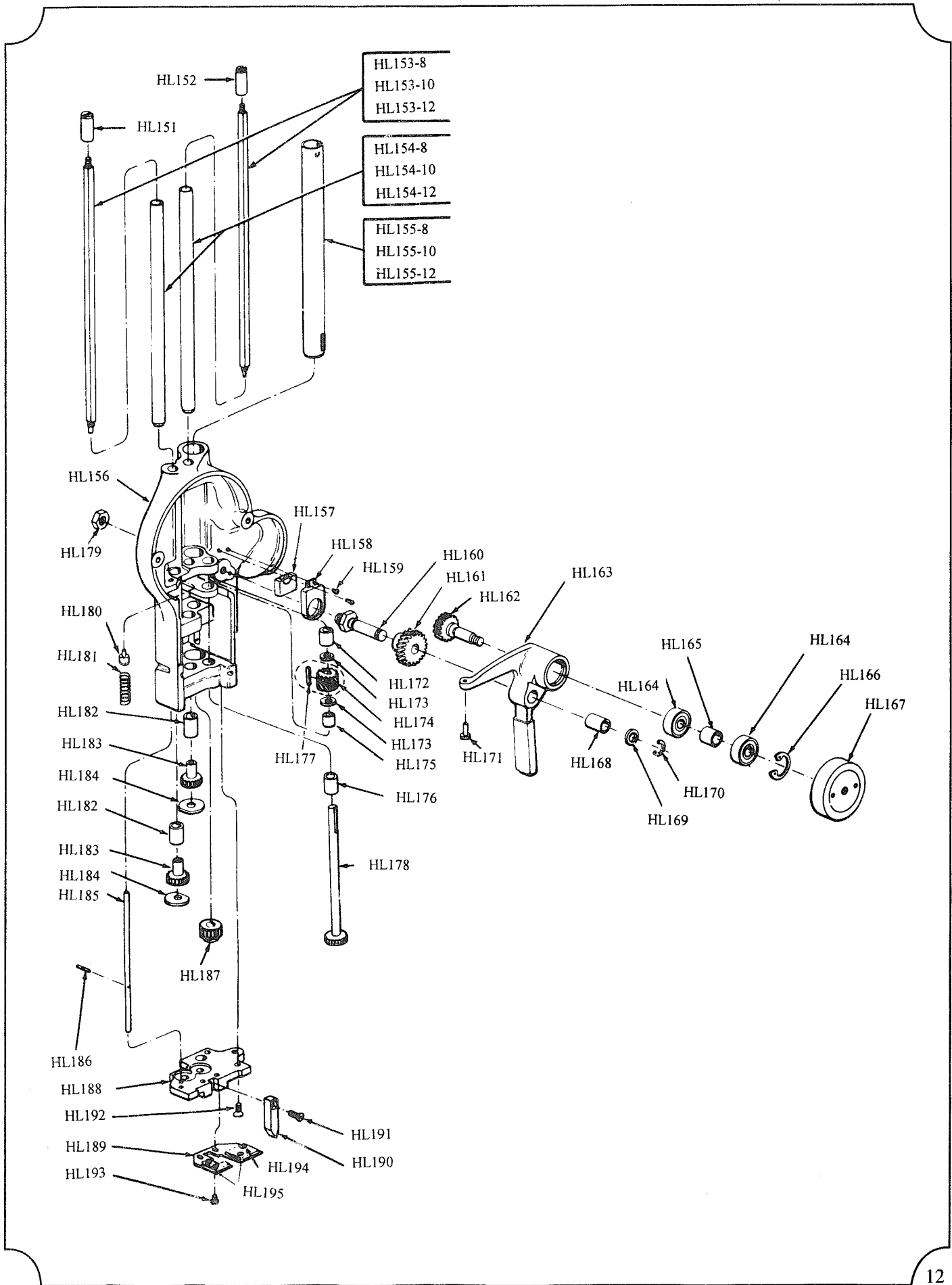

- | |
|----------|
| HL153-8 |
| HL153-10 |
| HL153-12 |
-
- | |
|----------|
| HL154-8 |
| HL154-10 |
| HL154-12 |
-
- | |
|----------|
| HL155-8 |
| HL155-10 |
| HL155-12 |

下齿轮托架组

Lower Gear Bracket Assembly

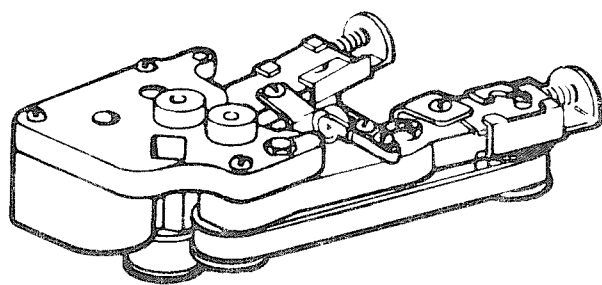

零件号 Part No.	名称 Description	数量 No.Req'd
HL196	L.H.Shaft Extension 8牙齿轮轴	1
HL197	R.H.Shaft Extension 滑轮轴	1
HL198	Adjusting Screw 磨刀架盖板螺钉	1
HL199	Screw 半圆头螺钉	1
HL200	Screw 半圆头螺钉	3
HL201	Gear Cover 磨刀架盖板	1
HL202	Screw 挡片螺钉	2
HL203	Guide Back of Standard 挡片	1
HL204	Spring for Arm 夹紧臂弹簧	1
HL205	Clamping Arm for Shoe 夹紧臂	1
HL206	Screw for Clamping Arm 夹紧臂螺钉	1
HL207	Screw 紧定滚轮螺钉	4
HL208	Stabilizer 紧定滚轮组件	2
HL209	Nut for Sharpener Shoe Screw 六角螺母	2
HL210	Screw #4-36×3/16 Fillister Head 圆柱头螺钉	2
HL211	Intermediate Gear 双联齿轮	1
HL212	Lower Gear Bracket with Cover 磨刀架	1
HL213	Wear Plate 耐磨板	2
HL214	Spring for Pulley Slide 滑动小轮弹簧	2
HL215	R.H.Slide with Pulley 左滑动小轮组件	1
HL216	Slide with Pulley 右滑动小轮组件	1
HL217	Gear on Screw Shaft 24牙齿轮	1
HL218	Grease Plug 平端紧定螺钉	1
HL219	Bearing for Screw Shaft 双向丝杆衬套	1
HL220	Bearing for Intermediate Gear 双联齿轮衬套	1
HL221	Bearing for Shaft Extension 传动小轮衬套	2
HL222	Front Pulley for Belt 传动小轮	1
HL223	Roll Pin 弹性圆柱销	2
HL224	Neoprene Band for Pulley 传动小轮橡胶套	2
HL225	R.H.Pre-set Sharpener Shoe(Only) 右磨刀垫	1
HL226	L.H.Pre-set Sharpener Shoe(Only) 左磨刀垫	1
HL227	Washer 磨刀垫螺钉垫片	4
HL228	R.H.Pre-set Sharpener Shoe 右磨刀垫组件	1
HL229	L.H.Pre-set Sharpener Shoe 左磨刀垫组件	1
HL230	Bushing for Sharpener Shoe 磨刀垫螺钉衬套	2
HL231	R.H. Sharpener Shoe Spring 右弹簧	1
HL232	L.H. Sharpener Shoe Spring 左弹簧	1
HL233	Screw for Sharpener Shoe 磨刀垫螺钉	2
HL234	Shoe Screw 内六角锥端紧定螺钉	1
HL235	Jam Nut 小六角较扁螺母	1
HL236	Belt 砂带	2

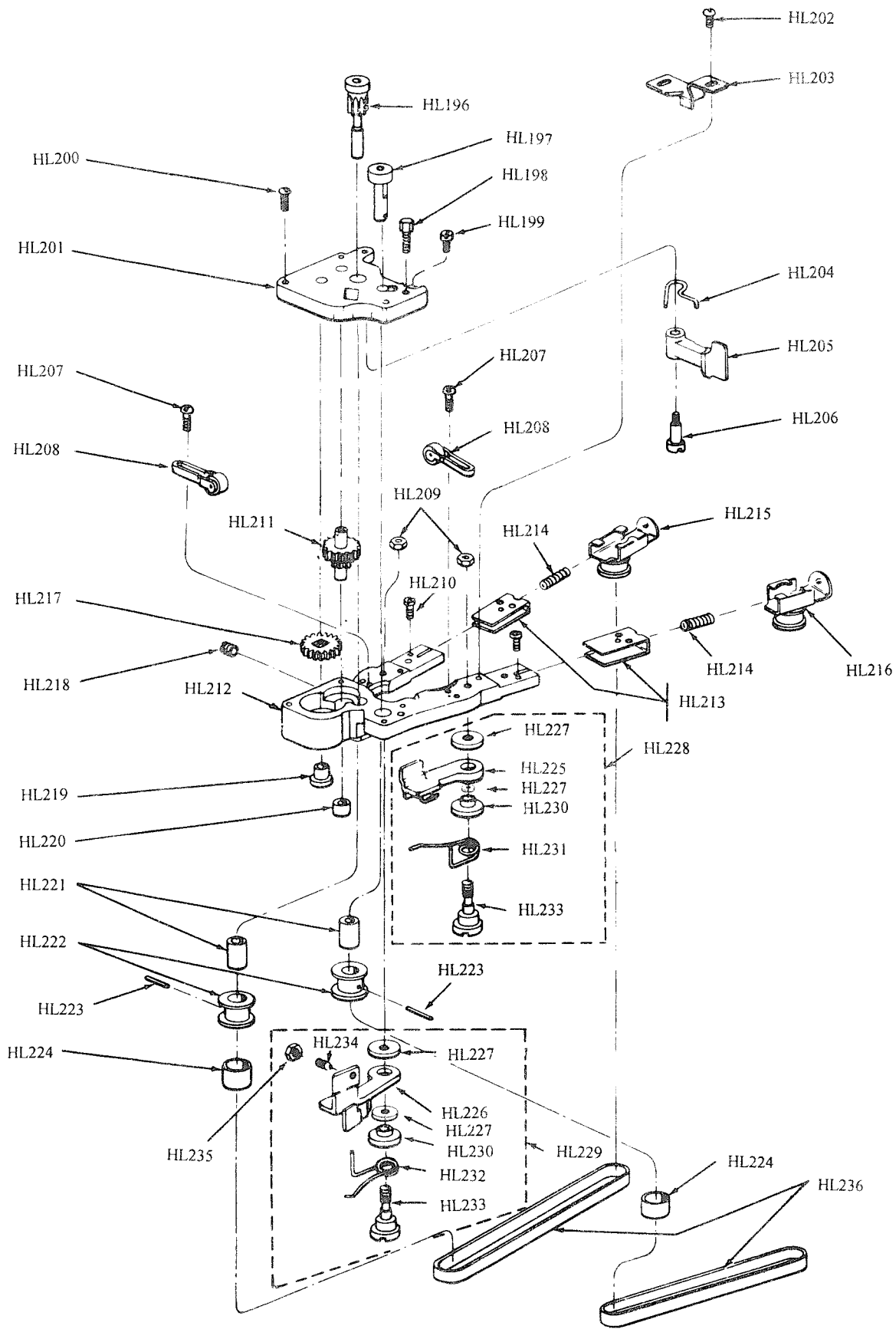

附件

Accessories

零件号 Part No.	名称 Description	数量 No.Req'd
HL237	Wrench 六角扳手	1
HL239	Square Sleeve 四角套筒	1
HL240	Attachment & Wire Plug 电源线插头组件	1
HL008	Knife 刀片	1
HL236	Belt 砂带	10

10"、8"、6" 不同尺寸零件表

Different Size Parts List

零件号 Part No.	名称 Description	尺寸规格 Size		
		10"	8"	6"
HL150	Knife Guard Rod 压脚杆	364	314	314
HL154	Tube for Square Shaft 方导杆管套	245	195	195
HL155	Tube for Screw Shaft 丝杆管套	244	194	194
HL153	Square Shaft 方导杆	297	247	247
HL113	Screw Shaft 双向丝杆	369	319	269
HL092	Knife Slide 刀壳组件	269	219	169
HL008	Knife 刀片	294	244	194
HL091	Standard 立柱	274	224	174